

# Gear Couplings

## RINGFEDER® TNZ ZCH

### Standard hubs with one-piece casing

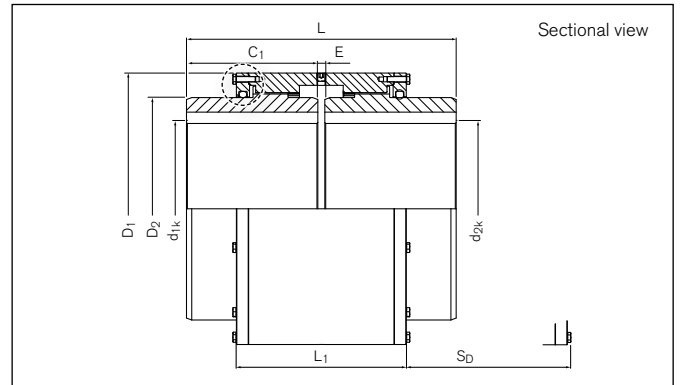
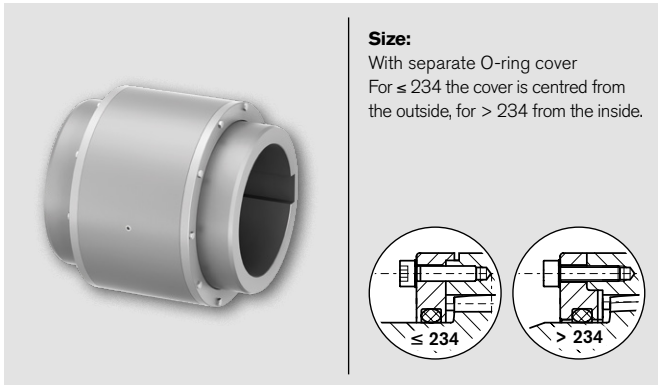

Identifier	Size	$T_{KN}$	$T_{Kmax}$	$n_{max}$	$d_{1k}$ min-max	$d_{2k}$ min-max	$D_1$	$D_2$
<b>ZCH</b>		Nm	Nm	1/min	mm	mm	mm	mm
XCD106	69	1750	3500	6000	12 - 50	12 - 50	98	69
XCD108	85	2750	5500	4600	18 - 60	18 - 60	115	85
XCD110	107	5500	11000	4200	28 - 75	28 - 75	145	107
XCD113	133	8500	17000	4000	40 - 95	40 - 95	176	133
XCD115	152	13500	27000	3850	50 - 110	50 - 110	196	152
XCD117	179	22000	44000	3700	60 - 130	60 - 130	225	179
XCD120	209	35000	70000	3200	70 - 155	70 - 155	256	209
XCD123	234	43000	86000	2900	85 - 170	85 - 170	286	234
XCD125	254	68000	136000	2600	95 - 190	95 - 190	310	254
XCD127	279	82000	164000	2300	110 - 210	110 - 210	345	279
XCD130	305	150000	300000	2100	120 - 230	120 - 230	375	305
XCD135	355	195000	390000	1800	130 - 270	130 - 270	430	355

Identifier	Size	$C_1$	$E$	$L$	$L_1$	$S_D$	$\Delta K_r$	$\Delta K_w$	$J$	$V_{GR}$	$G_{Wsb}$
<b>ZCH</b>		mm	mm	mm	mm	mm	mm	degree	$10^{-3}kgm^2$	$dm^3$	kg
XCD106	69	43	3	89	76	30	0,42	2 x 0,5	6	0,07	4,6
XCD108	85	50	3	103	83	37	0,51	2 x 0,5	11	0,08	7,0
XCD110	107	62	3	127	94	48	0,66	2 x 0,5	33	0,13	13,3
XCD113	133	76	5	157	123	56	0,77	2 x 0,5	93	0,22	24,5
XCD115	152	90	5	185	127	70	0,99	2 x 0,5	155	0,38	33,8
XCD117	179	105	6	216	144	79	1,15	2 x 0,5	327	0,58	50,5
XCD120	209	120	6	246	160	92	1,33	2 x 0,5	595	0,75	75,9
XCD123	234	135	8	278	178	103	1,50	2 x 0,5	1040	1,25	104,7
XCD125	254	150	8	308	194	120	1,75	2 x 0,5	1551	1,92	131,7
XCD127	279	175	8	358	220	136	1,99	2 x 0,5	2713	2,67	185,4
XCD130	305	190	8	388	234	148	2,16	2 x 0,5	4071	3,33	236,6
XCD135	355	220	10	450	264	174	2,16	2 x 0,5	8208	5,00	368,0

- Examine the load capacity of the shaft-hub connection
- Hubs pilot bored, bore diameter 2 mm smaller than smallest finish bore diameter

To continue see next page

## Gear Couplings RINGFEDER® TNZ ZCH

### Explanation

<b>T<sub>KN</sub></b>	= Nom. Transmissible torque	<b>D<sub>1</sub></b>	= Outer diameter	<b>S<sub>D</sub></b>	= Disassembly Space
<b>T<sub>Kmax</sub></b>	= Max. transmissible torque of the coupling	<b>D<sub>2</sub></b>	= Outer diameter hub	<b>ΔK<sub>r</sub></b>	= Max. permissible radial misalignment
<b>n<sub>max</sub></b>	= Max. rotation speed	<b>C<sub>1</sub></b>	= Guided length in hub bore	<b>ΔK<sub>w</sub></b>	= Max. permissible angular misalignment
<b>d<sub>1kmin</sub>; d<sub>2kmin</sub></b>	= Min. bore diameter d <sub>1</sub> /d <sub>2</sub> with keyway acc. to DIN 6885-1	<b>E</b>	= Gap width between left and right component	<b>J</b>	= Total moment of inertia
<b>d<sub>1kmax</sub>; d<sub>2kmax</sub></b>	= Max. bore diameter d <sub>1</sub> /d <sub>2</sub> with keyway acc. to DIN 6885-1	<b>L</b>	= Total length	<b>V<sub>GR</sub></b>	= Grease volume
		<b>L<sub>1</sub></b>	= Overall length (without screws)	<b>G<sub>wsb</sub></b>	= Weight at smallest bore diameter

### Ordering example

Identifier	Size	d <sub>1k</sub>	d <sub>2k</sub>	Further details
XC0120	209	140	155	*

<sup>1)</sup> Without any other specification, we deliver as a standard: keyway acc. to DIN 6885-1, keyway side fit P9, bore tolerance H7; optional with set screw

Further information on  
**RINGFEDER® TNZ ZCH**

DISTRIBUTED BY



chainanddrives.com.au  
 support@chainanddrives.com.au

#### Disclaimer of liability

All technical details and notes are non-binding and cannot be used as a basis for legal claims. The user is obligated to determine whether the represented products meet his requirements. We reserve the right carry out modifications at any time in the interests of technical progress.