

Gear Couplings

RINGFEDER® TNZ ZCAZ / TNZ ZCBZ

Standard hubs and spacer

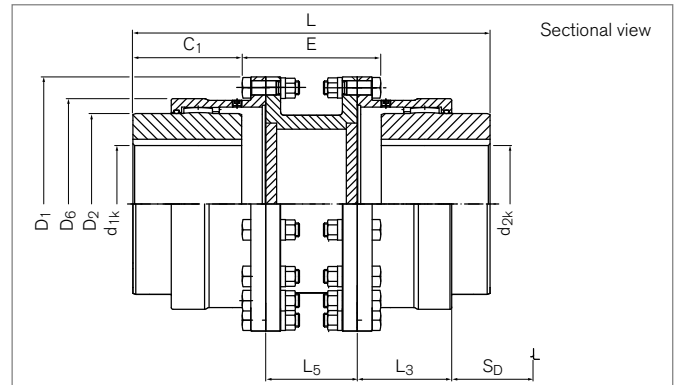
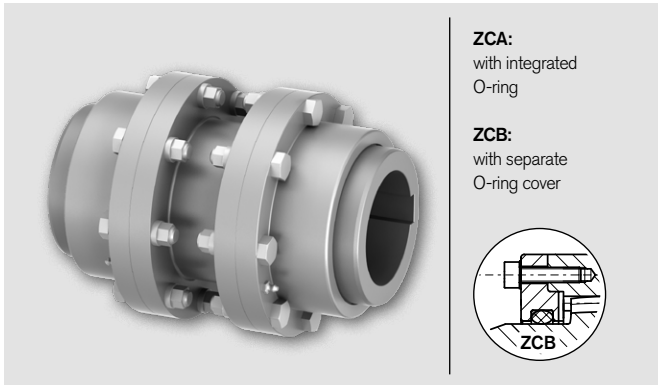

Identifier		Size	T _{KN}	T _{Kmax}	n _{max}	d _{1k} min-max	d _{2k} min-max	D ₁	D ₂	D ₆	C ₁
ZCAZ	ZCBZ		Nm	Nm	1/min	mm	mm	mm	mm	mm	mm
XC4106	---	69	1750	3500	On request	12 - 50	12 - 50	111	69	81,5	43
XC4108	---	85	2750	5500		18 - 60	18 - 60	152	85	103,5	50
XC4110	XC5110	107	5500	11000		28 - 75	28 - 75	178	107	127,5	62
XC4113	XC5113	133	8500	17000		40 - 95	40 - 95	213	133	156	76
XC4115	XC5115	152	13500	27000		50 - 110	50 - 110	240	152	181	90
XC4117	XC5117	179	22000	44000		60 - 130	60 - 130	280	179	209	105
XC4120	XC5120	209	35000	70000		70 - 155	70 - 155	318	209	245,5	120
XC4123	XC5123	234	43000	86000		85 - 170	85 - 170	346	234	274	135
XC4125	XC5125	254	68000	136000		95 - 190	95 - 190	389	254	307	150
XC4127	XC5127	279	82000	164000		110 - 210	110 - 210	425	279	334,5	175
XC4130	XC5130	305	150000	300000		120 - 230	120 - 230	457	305	366	190
XC4135	XC5135	355	195000	390000		130 - 270	130 - 270	527	355	423	220

Identifier		Size	E _{min}	L _{min}	L ₃	L _{5min}	S _D	ΔK _r	ΔK _w	J	V _{GR}	GW _{sb}
ZCAZ	ZCBZ		mm	mm	mm	mm	mm	mm	degree	10 ⁻³ kgm ²	dm ³	kg
XC4106	---	69	67	153	39	60	30	Depends on E	2 x 0,5	Depends on E	2 x 0,035	Depends on E
XC4108	---	85	93	193	46	80	37		2 x 0,5		2 x 0,040	
XC4110	XC5110	107	115	239	59	90	48		2 x 0,5		2 x 0,065	
XC4113	XC5113	133	129	281	69	110	56		2 x 0,5		2 x 0,110	
XC4115	XC5115	152	153	333	83	110	70		2 x 0,5		2 x 0,190	
XC4117	XC5117	179	178	388	93	130	79		2 x 0,5		2 x 0,290	
XC4120	XC5120	209	188	428	106	130	92		2 x 0,5		2 x 0,375	
XC4123	XC5123	234	196	466	118	130	103		2 x 0,5		2 x 0,625	
XC4125	XC5125	254	252	552	138	160	120		2 x 0,5		2 x 0,960	
XC4127	XC5127	279	258	608	154	160	136		2 x 0,5		2 x 1,335	
XC4130	XC5130	305	268	648	166	160	148		2 x 0,5		2 x 1,665	
XC4135	XC5135	355	294	734	193	160	174		2 x 0,5		2 x 2,500	

- Examine the load capacity of the shaft-hub connection
- Hubs pilot bored, bore diameter 2 mm smaller than smallest finish bore diameter

To continue see next page

Gear Couplings RINGFEDER® TNZ ZCAZ / TNZ ZCBZ

Explanation

T_{KN}	= Nom. Transmissible torque	D₁	= Outer diameter	L_{5min}	= Min. length of spacer
T_{Kmax}	= Max. transmissible torque of the coupling	D₂	= Outer diameter hub	S_D	= Disassembly Space
n_{max}	= Max. rotation speed	D₆	= Diameter	ΔK_r	= Max. permissible radial misalignment
d_{1kmin};d_{2kmin}	= Min. bore diameter d ₁ /d ₂ with keyway acc. to DIN 6885-1	C₁	= Guided length in hub bore	ΔK_w	= Max. permissible angular misalignment
d_{1kmax};d_{2kmax}	= Max. bore diameter d ₁ /d ₂ with keyway acc. to DIN 6885-1	E_{min}	= Min. gap width between left and right component	J	= Total moment of inertia
		L_{min}	= Minimum length	V_{GR}	= Grease volume
		L₃	= Length	Gw_{sb}	= Weight at smallest bore diameter

Ordering example

Identifier	Size	d _{1k}	d _{2k}	Further details
XC5117	179	120	120	*

^{*)} Without any other specification, we deliver as a standard: keyway acc. to DIN 6885-1, keyway side fit P9, bore tolerance H7; optional with set screw

Further information on
RINGFEDER® TNZ ZCAZ / TNZ ZCBZ

DISTRIBUTED BY



chainanddrives.com.au
 support@chainanddrives.com.au

Disclaimer of liability

All technical details and notes are non-binding and cannot be used as a basis for legal claims. The user is obligated to determine whether the represented products meet his requirements. We reserve the right carry out modifications at any time in the interests of technical progress.