

Gear Couplings

RINGFEDER® TNZ ZCAF / TNZ ZCBF

Intermediate shaft and rigid counter-flanges

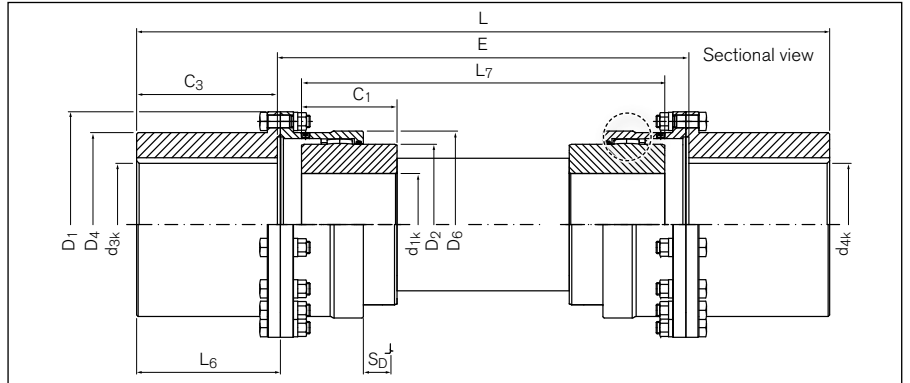
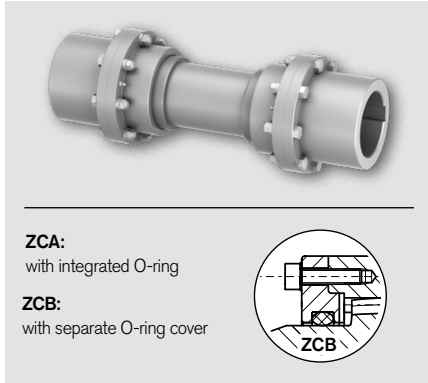

Identifier		Size	T _{KN}	T _{Kmax}	n _{max}	d _{1k} min-max	d _{3k} min-max	d _{4k} min-max	D ₁	D ₂	D ₄	D ₆	C ₁	C ₃
ZCAF	ZCBF		Nm	Nm	1/min	mm	mm	mm	mm	mm	mm	mm	mm	mm
XC6106	---	69	1750	3500	On request	12 - 50	12 - 55	0 - 55	111	69	80	81,5	43	40
XC6108	---	85	2750	5500		18 - 60	18 - 75	0 - 75	152	85	103,5	103,5	50	47
XC6110	XC7110	107	5500	11000		28 - 75	28 - 95	0 - 95	178	107	126	127,5	62	58
XC6113	XC7113	133	8500	17000		40 - 95	40 - 110	0 - 110	213	133	152	156	76	74
XC6115	XC7115	152	13500	27000		50 - 110	50 - 130	0 - 130	240	152	178	181	90	87
XC6117	XC7117	179	22000	44000		60 - 130	60 - 155	55 - 155	280	179	208	209	105	101
XC6120	XC7120	209	35000	70000		70 - 155	70 - 180	65 - 180	318	209	245	245,5	120	113
XC6123	XC7123	234	43000	86000		85 - 170	85 - 200	80 - 200	346	234	270	274	135	129
XC6125	XC7125	254	68000	136000		95 - 190	95 - 230	90 - 230	389	254	305	307	150	150
XC6127	XC7127	279	82000	164000		110 - 210	110 - 250	100 - 250	425	279	330	334,5	175	175
XC6130	XC7130	305	150000	300000		120 - 230	120 - 280	120 - 280	457	305	362	366	190	190
XC6135	XC7135	355	195000	390000		130 - 270	130 - 330	150 - 330	527	355	419	423	220	220

Identifier		Size	E _{min}	L	L ₆	L _{7min}	S _D	ΔK _r	ΔK _w	J	V _{GR}	G _{Wsb}
ZCAF	ZCBF		mm	mm	mm	mm	mm	mm	degree	10 ⁻³ kgm ²	dm ³	kg
XC6106	---	69	99	179	43,5	86	30	Depends on E	2 x 0,5	Depends on E	2 x 0,035	Depends on E
XC6108	---	85	119	213	50,5	100	37		2 x 0,5		2 x 0,040	
XC6110	XC7110	107	155	271	61,5	124	48		2 x 0,5		2 x 0,065	
XC6113	XC7113	133	177	325	77,5	152	56		2 x 0,5		2 x 0,110	
XC6115	XC7115	152	229	403	90,5	180	70		2 x 0,5		2 x 0,190	
XC6117	XC7117	179	264	466	104	210	79		2 x 0,5		2 x 0,290	
XC6120	XC7120	209	304	530	116,5	240	92		2 x 0,5		2 x 0,375	
XC6123	XC7123	234	344	602	133	270	103		2 x 0,5		2 x 0,625	
XC6125	XC7125	254	400	700	154	300	120		2 x 0,5		2 x 0,960	
XC6127	XC7127	279	456	806	179	350	136		2 x 0,5		2 x 1,335	
XC6130	XC7130	305	500	880	196	380	148		2 x 0,5		2 x 1,665	
XC6135	XC7135	355	590	1040	228	440	174		2 x 0,5		2 x 2,500	

- Examine the load capacity of the shaft-hub connection
- Hubs pilot bored, bore diameter 2 mm smaller than smallest finish bore diameter, without intermediate shaft

To continue see next page

Gear Couplings RINGFEDER® TNZ ZCAF / TNZ ZCBF

Explanation

T_{KN} = Nom. Transmissible torque	D₁ = Outer diameter	L₆ = Length of basic part
T_{Kmax} = Max. transmissible torque of the coupling	D₂ = Outer diameter hub	L_{7min} = Min. length of the middle connection part
n_{max} = Max. rotation speed	D₄ = Outer diameter hub	S_D = Disassembly Space
d_{1kmin} ;	D₆ = Diameter	ΔK_r = Max. permissible radial misalignment
d_{3kmin} ;	C₁ = Guided length in hub bore	ΔK_w = Max. permissible angular misalignment
d_{4kmin} = Min. bore diameter d ₁ /d ₃ /d ₄ with keyway acc. to DIN 6885-1	C₃ = Guided length in hub bore	J = Total moment of inertia
d_{1kmax} ;	E_{min} = Min. gap width between left and right component	V_{GR} = Grease volume
d_{3kmax} ;	L = Total length	GW_{sb} = Weight at smallest bore diameter
d_{4kmax} = Max. bore diameter d ₁ /d ₃ /d ₄ with keyway acc. to DIN 6885-1		

Ordering example

Identifier	Size	d _{3k}	d _{4k}	Further details
XC6127	279	180	230	*

^{*)} Without any other specification, we deliver as a standard: keyway acc. to DIN 6885-1, keyway side fit P9, bore tolerance H7; optional with set screw

Further information on
RINGFEDER® TNZ ZCAF / TNZ ZCBF

DISTRIBUTED BY



chainanddrives.com.au
 support@chainanddrives.com.au

Disclaimer of liability

All technical details and notes are non-binding and cannot be used as a basis for legal claims. The user is obligated to determine whether the represented products meet his requirements. We reserve the right carry out modifications at any time in the interests of technical progress.