

Sprag Type Freewheel Cage Assembly NSC Model



❖ Features:

- NSC cage freewheels are sprag type freewheels. NSC assembly to be installed between Inner and Outer races of customer arrangement.
- NSC cage assembly must be installed in a Design providing races, bearing support for axial & radial loads, lubrication & sealing.
- Depending on operating data, oil or grease lubrication must be provided in mounting arrangement.
- Inner race and Outer race or Housing is in Customer scope. It must be Case Hardening Steel material with Hardness 60 ± 3 .
- Case hardening depth Minimum 1.5 mm must be used, Surface roughness in between $1.6\ \mu\text{m}$ to $6.3\ \mu\text{m}$ of Both Races.

◆ Mounting Example:

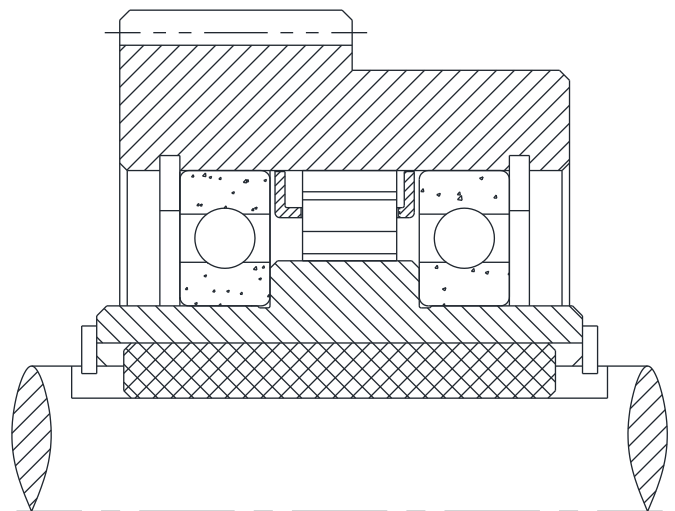

NSC Cage Assembly

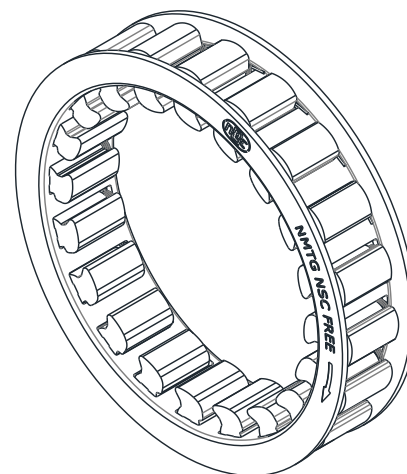
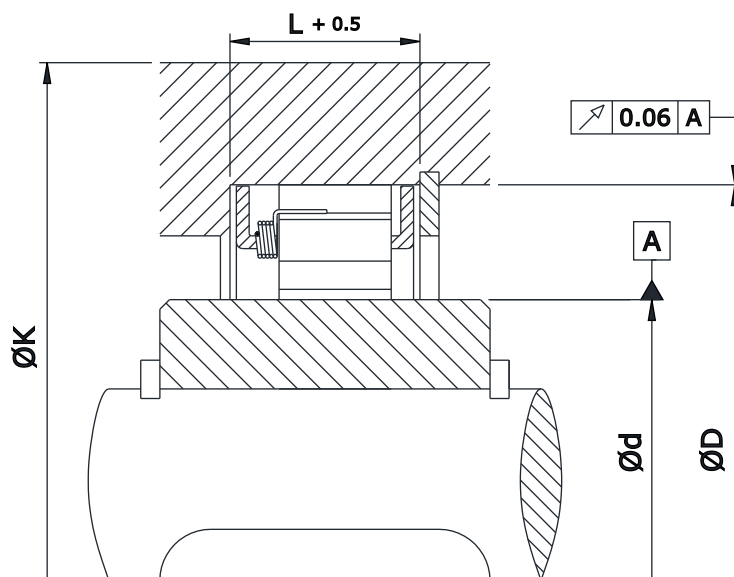

Model	Nominal Torque (Tn) Nm	$\varnothing d \begin{smallmatrix} -0.01 \\ -0.03 \end{smallmatrix}$ mm	$\varnothing D \pm 0.01$ mm	L mm	$\varnothing K$ mm	No. of Sprag	Weight kg
NSC 37D	275	37	55	14.5	75	14	0.06
NSC 44D	505	44	62	14.5	90	20	0.08
NSC 50H	685	50	68	18.5	90	20	0.10
NSC 57H	955	57	75	18.5	105	24	0.13
NSC 72F	2110	72	90	23.5	135	32	0.23
NSC 82C	2310	82	100	25	140	36	0.26
NSC 107C	3320	107	125	25	170	48	0.35
NSC 127C	4930	127	145	25	210	56	0.40

Notes :

- 1) Function : Backstopping, Overrunning, Indexing
- 2) $T_{max} = 2 \times T_n$.
- 3) Ready to fit, Oil & Grease lubrication required in Customer arrangement.

- 4) Other sizes on request.
- 5) All dimensions are in mm.

DISTRIBUTED BY

Ordering Example :

- When ordering please specify cage assembly model.
- **Example: NSC 44D**

