

The BANDO logo consists of the word "BANDO" in a bold, black, sans-serif font, centered between two horizontal bars. The top bar is red and the bottom bar is black.

DISTRIBUTED BY

The logo for CHAIN & DRIVES features the words "CHAIN" and "DRIVES" in a blue, sans-serif font, separated by a stylized gear icon.

chainanddrives.com.au
support@chainanddrives.com.au

POWER ACE[®] ARAMID V-BELTS SINGLES & COMBO

NEW

High-modulus/low-elongation
aramid cord

50% or higher
breaking strength

40% or higher
transmission capacity

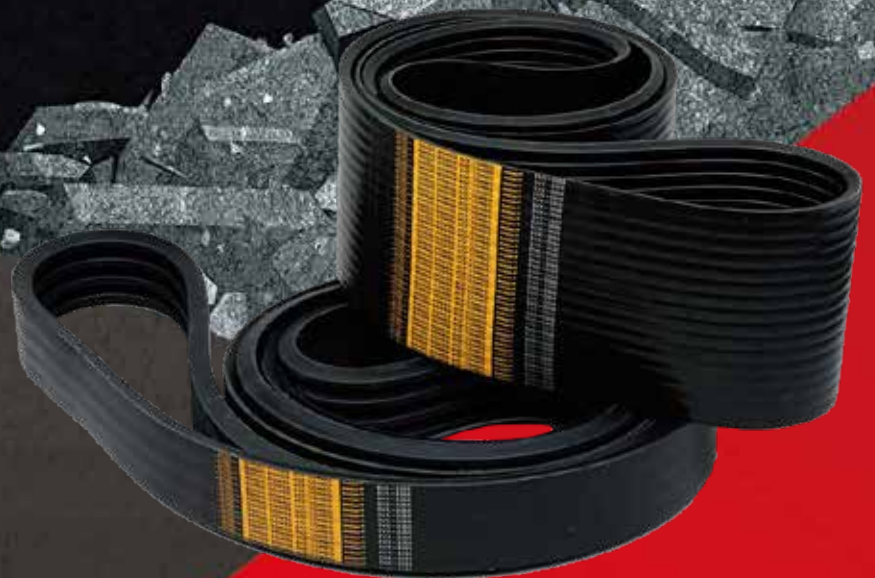

POWER ACE®

ARAMID V-BELTS

SINGLES & COMBO

Power Ace® Aramid belts are constructed with high modulus aramid cords to maintain length stability and to withstand severe shock loads, making them ideally suited for oil, gas, aggregate and lumber industry applications. Meets ARPM standards for heat resistance and static conductivity.

BAN/SET®

*System eliminates matching requirements.

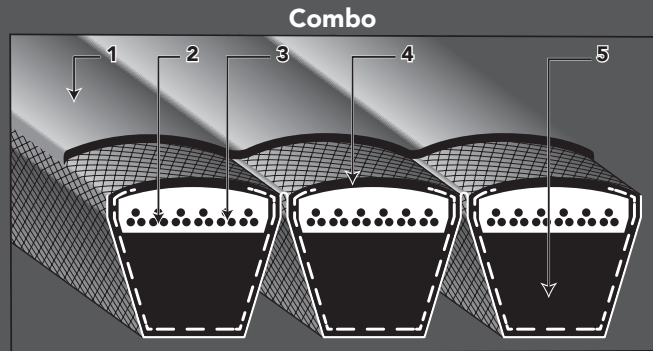
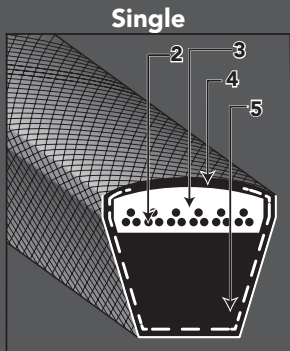

1. Tie band on Combo belts: New construction delivers excellent anti-abrasion performance and adhesion, leading to increased service life.
2. High-modulus aramid cords: Increase the breaking strength by more than 50% compared to polyester cord V-belts. 40% higher transmission capacity than polyester V-belts.
3. Banprene® adhesion rubber.
4. Rubber impregnated canvas: Belts are static conductive per ARPM bulletin IP3-3.
5. Banprene® compression rubber provides premium cord support and sheave sidewall contact.

Single and Combo belts are *Banset® matched.

Part Number Example

8VK 1250
 ———— Belt Size (Effective Outside Length) 125 inches
 ———— Belt Section

Nominal Dimension



Single Sizes			
Belt Section	Top Width W (Inches)	Height H (Inches)	Size Range
5VK	0.62	0.54	600 - 3550
8VK	1.0	0.88	1060 - 5600

Part Number Example

3 - 8VK 1250
 ———— Belt Size (Effective Outside Length) 125 inches
 ———— Belt Section
 ———— Number of ribs

Nominal Dimension

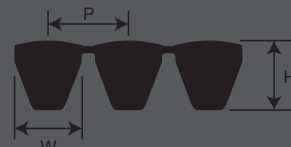

Combo Sizes				
Belt Section	Top Width W (Inches)	Height H (Inches)	Pitch Between Belts P (Inches)	Size Range
5VK	0.62	0.63	0.69	600 - 3550
8VK	1.0	0.98	1.13	1060 - 5600



TRANSMISSION CAPACITY

Excessive Load Test for Service Life

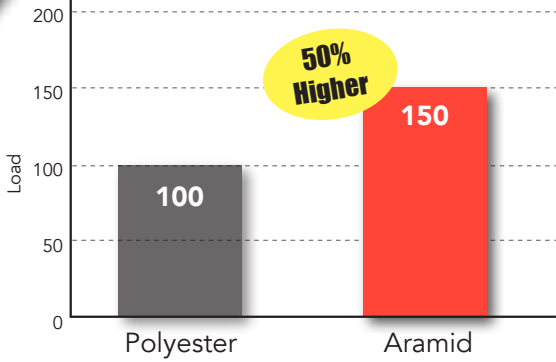

Strength Test

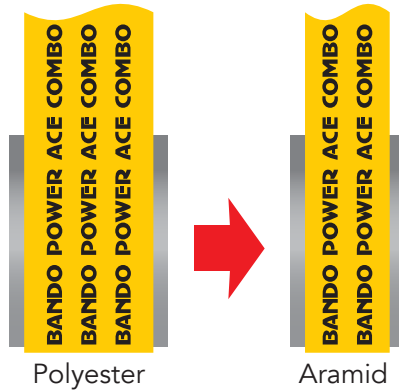
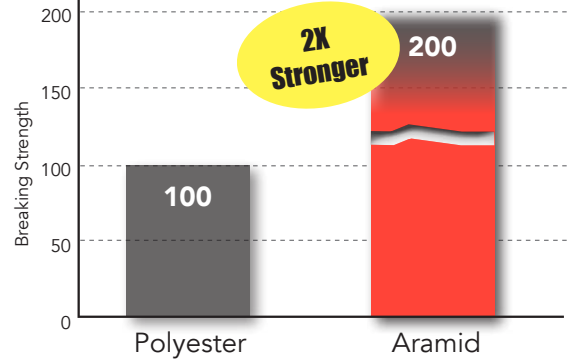

Drives can be designed utilizing fewer ribs, reducing design weight.

Field Test Result of Service Lifetime

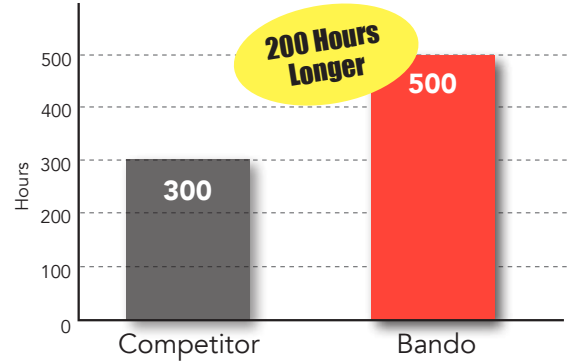

Service lifetime tested longer than our competitor during field testing on pavement milling machines.

Basic Horsepower Comparison (5VK)

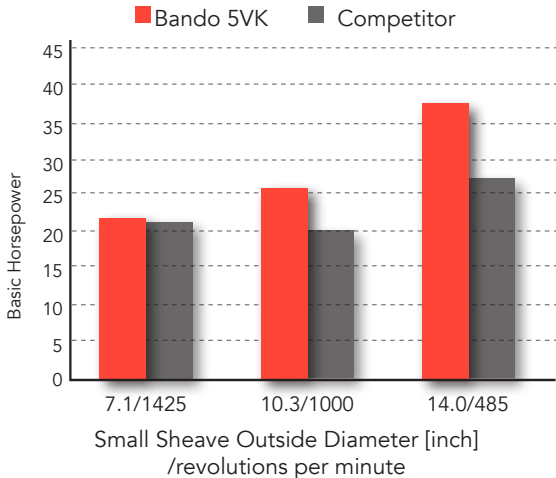

Basic Horsepower Comparison (8VK)

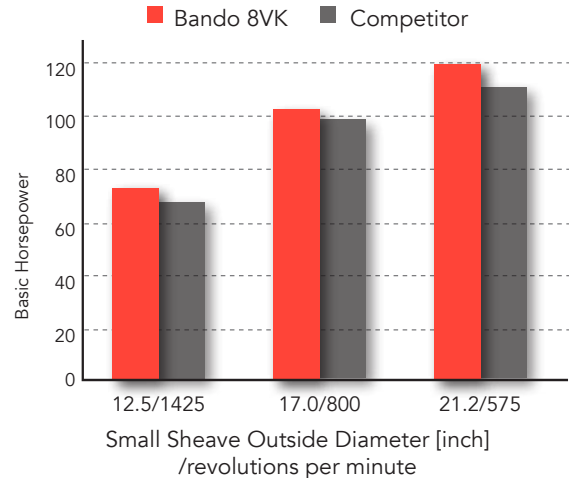

Shock-Load Absorbing, Power Ace® Aramid Single & Combo V-Belts

Especially suitable for high shock-load applications, such as pavement milling or wood chippers. Service lifetime is longer than other leading manufacturers based on field testing.

5 VK SINGLES			
Part Number	Effective Outside Length (Inches)	Part Number	Effective Outside Length (Inches)
5VK800	80.0	5VK1700	170.0
5VK850	85.0	5VK1800	180.0
5VK900	90.0	5VK1900	190.0
5VK950	95.0	5VK2000	200.0
5VK1000	100.0	5VK2120	212.0
5VK1060	106.0	5VK2240	224.0
5VK1120	112.0	5VK2360	236.0
5VK1180	118.0	5VK2500	250.0
5VK1250	125.0	5VK2650	265.0
5VK1320	132.0	5VK2800	280.0
5VK1400	140.0	5VK3000	300.0
5VK1500	150.0	5VK3150	315.0
5VK1600	160.0	5VK3350	335.0

8 VK SINGLES			
Part Number	Effective Outside Length (Inches)	Part Number	Effective Outside Length (Inches)
8VK1400	140.0	8VK2360	236.0
8VK1500	150.0	8VK2500	250.0
8VK1600	160.0	8VK2650	265.0
8VK1700	170.0	8VK2800	280.0
8VK1800	180.0	8VK3000	300.0
8VK1900	190.0	8VK3150	315.0
8VK2000	200.0	8VK3350	335.0
8VK2120	212.0	8VK3550	355.0
8VK2240	224.0		

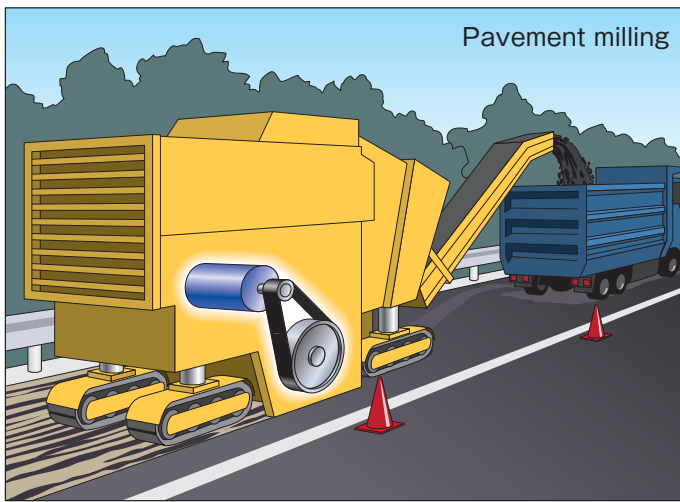

Pavement milling

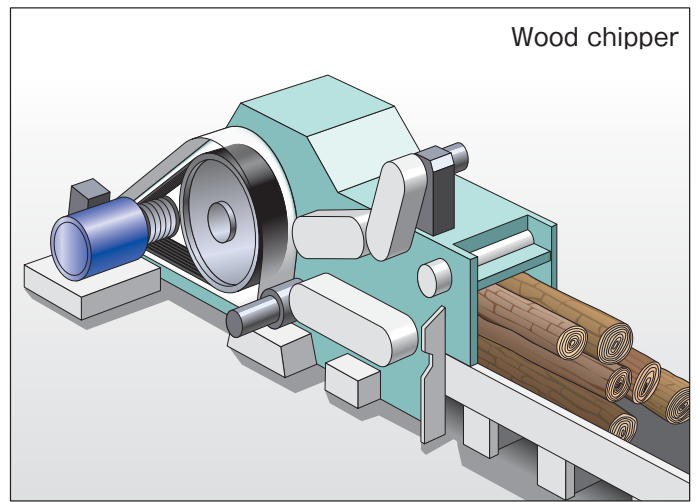

Wood chipper

5 VK COMBOS			
Part Number	Effective Outside Length (Inches)	Part Number	Effective Outside Length (Inches)
5VK600	60.0	5VK1500	150.0
5VK630	63.0	5VK1600	160.0
5VK670	67.0	5VK1620	162.0
5VK710	71.0	5VK1700	170.0
5VK750	75.0	5VK1800	180.0
5VK760	76.0	5VK1900	190.0
5VK800	80.0	5VK1920	192.0
5VK850	85.0	5VK1955	195.5
5VK860	86.0	5VK2000	200.0
5VK900	90.0	5VK2080	208.0
5VK920	92.0	5VK2120	212.0
5VK950	95.0	5VK2150	215.0
5VK960	96.0	5VK2200	220.0
5VK970	97.0	5VK2240	224.0
5VK1000	100.0	5VK2360	236.0
5VK1060	106.0	5VK2500	250.0
5VK1120	112.0	5VK2650	265.0
5VK1180	118.0	5VK2800	280.0
5VK1250	125.0	5VK3000	300.0
5VK1280	128.0	5VK3150	315.0
5VK1320	132.0	5VK3350	335.0
5VK1400	140.0	5VK3550	355.0
5VK1460	146.0		

8 VK COMBOS			
Part Number	Effective Outside Length (Inches)	Part Number	Effective Outside Length (Inches)
8VK1060	106.0	8VK2500	250.0
8VK1120	112.0	8VK2650	265.0
8VK1180	118.0	8VK2730	273.0
8VK1250	125.0	8VK2800	280.0
8VK1320	132.0	8VK3000	300.0
8VK1400	140.0	8VK3150	315.0
8VK1500	150.0	8VK3350	335.0
8VK1600	160.0	8VK3550	355.0
8VK1700	170.0	8VK3750	375.0
8VK1800	180.0	8VK4000	400.0
8VK1900	190.0	8VK4250	425.0
8VK2000	200.0	8VK4500	450.0
8VK2120	212.0	8VK4750	475.0
8VK2240	224.0	8VK5000	500.0
8VK2360	236.0	8VK5600	560.0



Available up to 10 ribs wide.

Available up to 16 ribs wide.

Please contact us for other size availability.

DISTRIBUTED BY



chainanddrives.com.au
support@chainanddrives.com.au