

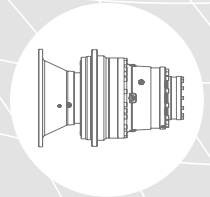

# HIGH TECH Lifting

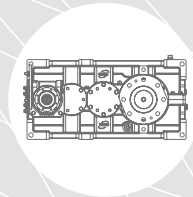

DISTRIBUTED BY

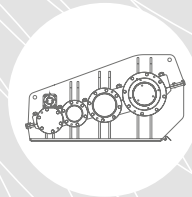

**CHAIN & DRIVES**  
COMPLETE BEARINGS  
& POWER TRANSMISSION

**SERVICE & SUPPORT**

Wangara, WA	Welshpool, WA	Arndell Park, NSW
+61 8 9303 4966	+61 8 6314 1155	+61 2 9674 8611
support@chainanddrives.com.au	salesnsw@chainanddrives.com.au	

[chainanddrives.com.au](http://chainanddrives.com.au)



800 Series

RIDUTTORI PER SOLLEVAMENTO  
GEAR UNITS FOR LIFTING APPLICATIONS  
GETRIEBE FÜR DEN HUBBETRIEB



- 1.1 Caratteristiche costruttive
- 1.2 Livelli di pressione sonora SPL [dB(A)]
- 1.3 Criteri di selezione
- 1.4 Verifiche
- 1.5 Stato di fornitura
- 1.6 Normative applicate
- 1.7 Designazione
- 1.8 Lubrificazione
- 1.9 Prestazioni riduttori
- 1.10 Momenti d'inerzia
- 1.11 Dimensioni
- 1.12 Estremità d'albero uscita

- Construction features*
- Mean sound pressure levels SPL [dB(A)]*
- Gear unit selection*
- Verification*
- Scope of the supply*
- Standards applied*
- Designation*
- Lubrication*
- Gear unit ratings*
- Moments of inertia*
- Dimensions*
- Output configuration*

- Konstruktionsmerkmale
- Schalldruckpegel SPL [dB(A)]
- Auswahlkriterien
- Überprüfungen
- Lieferzustand
- Angewendete Normen
- Bezeichnung
- Schmierung
- Leistungen der Getrieben
- Trägheitsmomente
- Applizierbare Motoren
- Enden der Abtriebswelle

- A4
- A5
- A6
- A9
- A12
- A14
- A18
- A27
- A32
- A34
- A36
- A41



## RXP3-E - Lifting Application

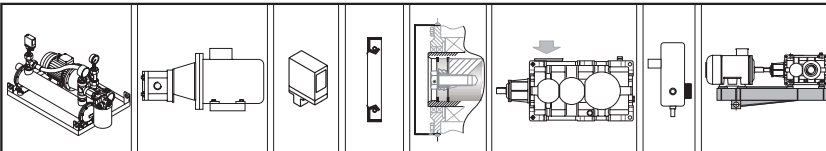

Accessori e opzioni  
Accessories and options  
Zubehör und Optionen



Gestione Revisione Cataloghi GSM  
Managing GSM Catalog Revisions  
Management Wiederholt Kataloge GSM



SIMBOLO SYMBOL SYMBOL	DEFINIZIONE	DEFINITION	DEFINITION	UNITA' DI MISURA MEASUREMENT UNIT MAßEINHEIT
<b>fa</b>	Fattore correttivo dell'altitudine	Altitude factor	Höhenkorrekturwert	
<b>Fa<sub>1-2</sub></b>	Carico assiale	<i>Axial load</i>	Axialbelastung	<b>N</b> 1N=0.1daN $\cong$ 0.1kg
<b>fc</b>	Coefficiente relativo alla temperatura dell'aria	Air temperature factor	Koeffizient bezüglich der Lufttemperatur	
<b>fd</b>	Fattore correttivo del tempo di lavoro	Operation time factor	Korrekturfaktor der Arbeitszeit	
<b>ff</b>	Fattore correttivo di aerazione con ventola	Fan cooling factor	Korrekturfaktor der Belüftung durch Lüfter	
<b>f<sub>Ga</sub></b>	Fattore di affidabilità	Safety factor	Zuverlässigkeitsfaktor	
<b>fm</b>	Fattore correttivo per la posizione di montaggio	Mounting position factor	Korrekturfaktor für einbaulage	
<b>f<sub>n</sub></b>	Fattore correttivo delle prestazioni	Input speed factor	Korrekturfaktor der Leistungen	
<b>fp</b>	Fattore correttivo della temperatura	Ambient temperature factor	Korrekturfaktor der Umgebungstemperatur	
<b>Fr<sub>1-2</sub></b>	Carico Radiale	<i>Radial load</i>	Radialbelastung	<b>N</b> 1N=0.1daN $\cong$ 0.1kg
<b>Fs</b>	Fattore di servizio	<i>Service factor</i>	Betriebsfaktor	
<b>Fs'</b>	Fattore di servizio riduttore	<i>Gearbox service factor</i>	Betriebsfaktor Getriebe	
<b>fv</b>	Fattore correttivo	Duty cycle factor	Korrekturfaktor	
<b>fw</b>	Coefficiente relativo alla temperatura dell'acqua	Water temperature factor	Koeffizient bezüglich der Wassertemperatur	
<b>IEC</b>	Motori accoppiabili	<i>Motor options</i>	Passende Motoren	
<b>ir</b>	Rapporto di trasmissione	<i>Ratio</i>	Übersetzungsverhältnis	
<b>J</b>	Momento d'inerzia della macchina e del riduttore ridotto all'asse motore	Machine and gear unit inertial load reflected to motor shaft	An der Motorachse reduziertes Trägheitsmoment der Maschine und des Getriebe	<b>Kgxm<sup>2</sup></b>
<b>J<sub>0</sub></b>	Momento d'inerzia delle masse rotanti sull'asse motore	Inertial load of rotating parts at motor shaft	Trägheitsmoment der an der Motorachse drehenden Massen	<b>Kgxm<sup>2</sup></b>
<b>kg</b>	Massa	<i>Mass</i>	Masse	<b>kg</b>
<b>n<sub>1</sub></b>	Velocità albero entrata	<i>Input speed</i>	Antriebsdrehzahl	<b>min<sup>-1</sup></b> 1 min <sup>-1</sup> = 6.283 rad.
<b>n<sub>2</sub></b>	Velocità albero in uscita	<i>Output speed</i>	Abtriebsdrehzahl	<b>min<sup>-1</sup></b> 1 min <sup>-1</sup> = 6.283 rad.
<b>P</b>	Potenza motore	<i>Gear unit power</i>	Leistung Getriebe	<b>kW</b>
<b>P'</b>	Potenza richiesta in uscita	<i>Output power</i>	Erforderliche Abtriebsleistung	<b>kW</b>
<b>P<sub>1</sub></b>	Potenza motoriduttore	<i>Gear motor power</i>	Leistung Getriebemotor	<b>kW</b> 1kW = 1.36 HP (PS)
<b>P<sub>c</sub></b>	Potenza corretta	<i>Correct power</i>	Tatsächliche Leistung	<b>kW</b>
<b>P<sub>N</sub></b>	Potenza nominale	Nominal power	Nennleistung	<b>kW</b>
<b>P<sub>ta</sub></b>	Potenza termica addizionale	Additional thermal power	Thermische Zusatzgrenzleistung	<b>kW</b>
<b>P<sub>tN</sub></b>	Potenza termica nominale	Thermal power rating	Termische Nenngrenzleistung	<b>kW</b>
<b>P<sub>t0</sub></b>	Potenza limite termico	<i>Limit thermal capacity</i>	Thermische Leistungsgrenze	<b>kW</b>
<b>RD (η)</b>	Rendimento dinamico	<i>Dynamic efficiency</i>	Dynamischer Wirkungsgrad	
<b>RS</b>	Rendimento statico	<i>Static efficiency</i>	Statischer Wirkungsgrad	
<b>T<sub>1f</sub></b>	Coppia frenante dinamica	Dynamic braking torque	Dynamisches Bremsmoment	<b>Nm</b>
<b>T<sub>1max</sub></b>	Coppia motrice massima	Max drive torque	Max. Antriebsmoment	<b>Nm</b>
<b>T<sub>1s</sub></b>	Coppia motrice di spunto	Starting torque	Anlaufantriebsdrehmoment	<b>Nm</b>
<b>T<sub>c</sub></b>	Temperatura ambiente	<i>Ambient temperature</i>	Umgebungstemperatur	<b>°C</b>
<b>T<sub>N</sub></b>	Coppia nominale	Nominal torque	Nenndrehmoment	<b>Nm, kNm</b>
<b>T<sub>Tbr</sub></b>	Coppia frenatura motore Autofrenante	Motor braking torque	Motorbremsmoment	<b>Nm, kNm</b>
<b>T<sub>1a</sub></b>	Coppia limite in ingresso del dispositivo antiretro	income limit torque for back-stop device	Grenzantriebsmoment der Rücklaufsperr	<b>Nm, kNm</b>
<b>Q<sub>rid</sub></b>	Quantità olio di riempimento del riduttore	Gearbox oil quantity	Öfüllmenge des Getriebe	
<b>Q<sub>min</sub></b>	Quantità olio minima	Minimum tank oil	Minimale Öfüllung im Tank	<b>Nm, kNm</b>
<b>M<sub>2s</sub></b>	Coppia di slittamento calettatore	Shrink disc slipping torque	Schrumpfscheiben-Schlupfmoment	<b>Nm, kNm</b>



RXP/800/E

800 Series

RIDUTTORI PER SOLLEVAMENTO  
GEAR UNITS FOR LIFTING APPLICATIONS  
GETRIEBE FÜR DEN HUBBETRIEB

**RXP3**  
**E**



A

A

800 Series

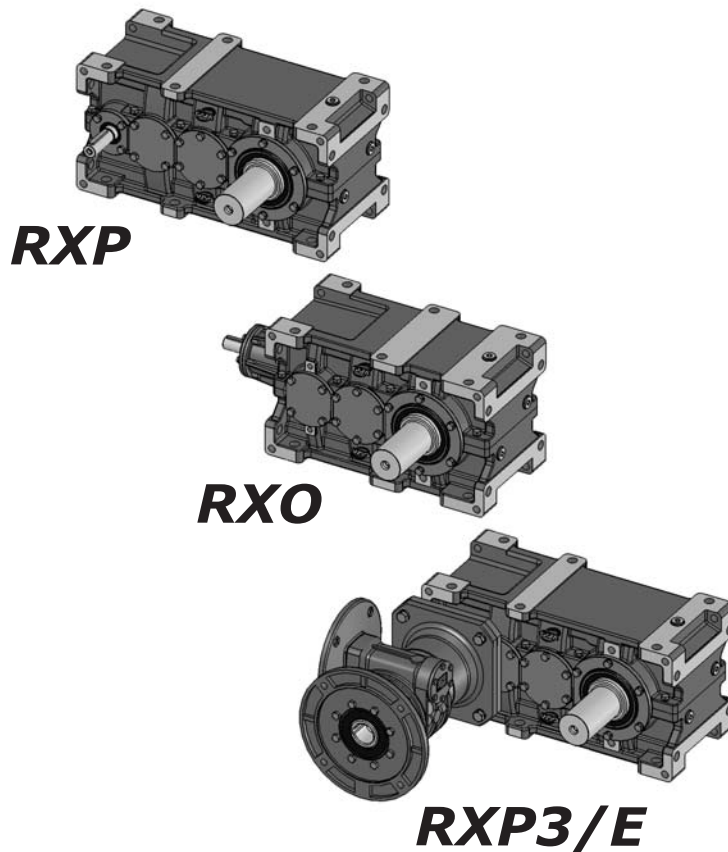

La serie RXP-E per sollevamento industriale deriva dalla gamma RX standard con l'aggiunta di un secondo riduttore differenziale: questi gruppi hanno degli alberi di ingresso e di uscita dimensionati per rispondere alle esigenze dei costruttori di apparati per sollevamento della meccanica medio-pesante.

Grazie ai criteri di progetto adottati, questi riduttori offrono un rapporto ottimale per quanto concerne la correlazione prestazioni/peso.

Il gruppo differenziale è un riduttore epicicloidale monostadio a doppio ingresso che si dispone tra il motore principale di comando ed il riduttore, per avere due distinte velocità all'albero lento di uscita.

Durante il funzionamento di uno dei due motori, l'altro rimane costantemente frenato.

La presenza del gruppo a vite senza fine interposto tra il motore secondario e la ruota planetaria e la possibilità di modificare il rapporto di trasmissione del gruppo vite senza fine, consente di ottenere sul secondario diverse velocità costanti in uscita e quindi di variare il rapporto tra la velocità primaria e la secondaria.

RXP-E series for industrial lifting takes origin from the standard RX to which has been given a secondary planetary gearbox.

These gearboxes have input and output shafts with wide dimensions in order to fulfil the expectations of heavy mechanical producers of lift systems, giving an optimum relationship between performances and weight.

The planetary differential gearbox has a double input that can be found between the main motor and the lift gearbox, with the purpose to obtain two different speeds to the output low shaft.

While one motor is working, the other one is constantly braking.

The change of worm ratio inside the planetary differential gearbox gives the opportunity of obtaining different output speeds, and so varying the relation between primary and secondary speeds.

Die RXP-E-Serie für den industriellen Hub stammt aus der Standard RX Reihe mit einem zusätzlichen zweiten Differential-Getriebe: diese Gruppen verfügen über dimensionierte Eingangs- und Ausgangswellen um den Anforderungen der Hubmaschinenkonstruktoren für die mittelschwere Mechanik gerecht zu werden.

Aufgrund der angewendeten Konstruktionskriterien bieten diese Getriebe ein optimales Verhältnis hinsichtlich Leistung und Gewicht.

Die differentielle Einheit ist ein einstufiges Planetengetriebe mit zwei Eingängen für die Hauptmotorsteuerung und das Getriebe, um zwei separate Geschwindigkeiten an der langsam laufenden Ausgangswelle zu erhalten. Während des Betriebes einer der beiden Motoren wird der andere ständig gebremst.

Die Schnecken zwischen dem Motor und dem sekundären Planetenrad und die Möglichkeit das Übersetzungsverhältnis der Schnecken zu ändern ermöglichen es auf dem Zweiten unterschiedliche konstante Ausgangsgeschwindigkeiten zu erhalten und daher das Verhältnis zwischen der ersten und der zweiten Geschwindigkeit zu variieren.



**1.1 Caratteristiche costruttive**

**1.1 Construction features**

**1.1 Construction features**

**Generalità**

Le dimensioni dei nostri riduttori e i rapporti di trasmissione seguono la serie dei numeri normali (serie di RENARD) Ra 20 UNI 2016. 68. I particolari accorgimenti adottati nella costruzione della carcassa esterna conferiscono ai nostri riduttori un'ampia versatilità di montaggio.

L'elevato numero di rapporti di trasmissione, consente in alcuni casi di scegliere un riduttore di taglia inferiore. La suddivisione della carcassa in due parti e i coperchi fissati con viti consentono una facile manutenzione.

Il gruppo costituito da riduttore accoppiato a differenziale si presenta come compatta ed economica soluzione per le esigenze di doppia velocità: consente infatti di ottenere con due motorizzazioni due velocità distinte di sollevamento; una principale (alta velocità), l'altra secondaria per gli accostamenti (bassa velocità), stanti fra loro in un rapporto fisso intero selezionabile a richiesta fra 4 e 19. Il gruppo, realizzato appositamente per il funzionamento intermittente tipico del settore di applicazione, richiede che l'entrata non comandata venga frenata.

L'ottimizzazione geometrica dell'ingranaggio unitamente ad una accurata lavorazione, assicura bassi livelli di rumorosità e garantisce elevati rendimenti:

**General description**

*Gear unit dimensions and transmission ratios follow a geometric progression based on the R20 series of preferred (or Renard) numbers in accordance with UNI 2016.68. The casing incorporates special design features to provide the utmost mounting versatility.*

*Our broad range of transmission ratios frequently allows selection of a smaller size. Split casing design and bolted covers ensure great ease of maintenance.*

*The gear unit is coupled with a differential unit to provide a compact, cost-effective solution for those applications that require two different lifting speeds, with a second approach (low) speed at a fixed ratio to main (high) speed. Speed ratios are whole numbers available in a range from 4 to 19. These units are expressly designed for intermittent duty - typically encountered in lifting applications - and require a brake on the non-driven input end.*

*Optimal gear geometry and high machining accuracy ensure low noise levels and higher efficiency:*

**Allgemeines**

Die Baugrößen und Übersetzungen unserer Getriebe sind der normalen Nummernserie (RENARD Reihe) Ra 20 UNI 2016.68 gemäß ausgelegt.

Die besonderen Konstruktionsmerkmale der Gehäuse ermöglichen die Montage unserer Getriebe in den unterschiedlichsten Einbaulagen.

Die zahlreichen Übersetzungsverhältnisse räumen in einigen Fällen die Möglichkeit ein, ein kleineres Getriebe wählen zu können. Die zweiteiligen Gehäuse und die mit Schrauben befestigten Deckel erlauben eine einfache Wartung.

Die aus Getriebe und Differential bestehende Einheit ist eine kompakte und wirtschaftliche Lösung für Anwendungen, in denen zwei Geschwindigkeiten gefordert werden: Sie ermöglicht bei Einsatz von zwei Motorisierungen den Erhalt zwei unterschiedlicher Hubgeschwindigkeiten. Eine Hauptgeschwindigkeit (hoch) und eine sekundäre Geschwindigkeit für die Annäherungssteuerungen (niedrig). Diese stehen untereinander in einer festgelegten Verhältniseinheit, die auf Anfrage zwischen 4 und 19 gewählt werden kann. Diese Einheit, extra für den in diesem Applikationsbereich typischen Schaltbetrieb realisiert, erfordert ein Abbremsen des nicht gesteuerten Antriebs.

Die geometrische Optimierung des Zahnrads verbunden mit einer akkuraten Bearbeitung gewährleistet niedrige Geräuschentwicklung und einen hohen Wirkungsgrad:

**Rendimento dall'estremità principale del differenziale  
Efficiency calculated from differential main shaft end  
Wirkungsgrad am Hauptwellenende des Differentials**

RD (%) Rendimento/Efficiency/Wirkungsgrad	<b>RXP3 / E</b>	92
--	-----------------	----

**Rodaggio per riduttore azionato dall'entrata secondaria del differenziale  
Break-in for gearbox operated by the secondary input of the differential gear  
Einlauf für Getriebe, die über den Sekundäreingang des Differentialtriebes betrieben werden**

Durante le fasi di avvio della macchina bisogna prevedere un periodo di rodaggio poichè il valore del rendimento risulta essere sensibilmente inferiore a quello nominale.

In questa fase si avranno assorbimenti elettrici maggiori a quelli indicati nei dati di targa delle tabelle delle prestazioni.

During the start-up phase of the machine, a break-in period must be provided, as the value of the efficiency is significantly lower than the nominal value.

In this phase, there will be more electric absorptions than those indicated in plate data of the performance tables.

Während der Anlaufphase der Maschine ist eine Einlaufphase erforderlich, da der Wirkungsgrad deutlich unter dem Nennwert liegt. In dieser Phase kommt es zu einer höheren Stromaufnahme, als in den Leistungstabellen angegeben.

**1.1 Caratteristiche costruttive****1.2 Livelli di pressione sonora SPL [dB(A)]**

Valori normali di produzione del livello medio di pressione sonora SPL (dB(A)) a velocità in entrata di 1450 giri/min (tolleranza +3 dB(A)). Valori misurati ad 1 m dalla superficie esterna del riduttore ed ottenuti su elaborazione di prove sperimentali. Per raffreddamento artificiale con ventola sommare ai valori di tabella: +2 dB(A) per ogni ventola. Per entrata ad un numero di giri diverso sommare i valori come in tabella. Per particolari esigenze è possibile fornire riduttori con livello medio di pressione sonora ridotto.

**1.1 Construction features****1.2 Mean sound pressure levels SPL [dB(A)]**

Noise levels are mean sound pressure levels SPL (dB(A)) and refer to normal operation at an input speed of 1450 rpm (tolerance +3 dB (A)). Measurements are taken at 1 m from the external surface of the gear unit and ratings are obtained by processing test data. For fan-cooled applications, add 2dB (A) to table values for each fan. For different input speeds, add the appropriate values indicated in the table below. Gear units with lower noise levels to suit particular needs are available on request.

**1.1 Construction features****1.2 Schalldruckpegel SPL [dB(A)]**

Normale Werte des durchschnittlichen Schalldruckpegels SPL (dB(A)) bei einer Antriebsdrehzahl von 1450 U/min (Toleranz +3 dB(A)). Werte, die aus den Auswertungen der experimentellen Tests, bei denen die Messung in 1 m Entfernung von der Getriebeoberfläche erfolgte, resultieren. Bei Vorliegen einer Zusatzluftkühlung durch Lüfter muss ein Korrekturwert von +2 dB(A) pro Lüfterrad zum Tabellenwert addiert werden. Bei abweichender Antriebsdrehzahl sind die Werte gemäß Tabellenangaben zu addieren. Im Fall besonderer Anforderungen können Getriebe mit einem reduzierten durchschnittlichen Schalldruckpegel geliefert werden.



	RXP3 / E		
	$i < 40$	$40 \leq i \leq 100$	$i > 100$
<b>802</b>	75	74	71
<b>804</b>	76	75	72
<b>806</b>	77	76	73
<b>808</b>	78	77	74
<b>810</b>	80	79	76
<b>812</b>	81	80	77
<b>814</b>	83	82	79
<b>816</b>	85	84	81
<b>818</b>	87	86	83
<b>820</b>	89	88	85
<b>822</b>	91	90	87
<b>824</b>	93	92	89

$n_1$ [min <sup>-1</sup> ]	<b>2750</b>	<b>2400</b>	<b>2000</b>	<b>1750</b>	<b>1000</b>	<b>750</b>	<b>500</b>	<b>350</b>
$\Delta$ SPL [dB(A)]	8	6	4	2	-2	-3	-4	-6

### 1.3 Criteri di selezione

I fattori di servizio da adottare per i diversi regimi di carico e durate (classi dei meccanismi) sono riportati inella tabella seguente nell'elaborazione della quale sono stati combinati i specifici criteri di selezione dei riduttori (durata, sovraccarichi, tipo di motorizzazione, frequenza avviamenti, velocità e affidabilità) con quelli dei meccanismi di sollevamento indicati dalle norme FEM 1.00/III'87 e ISO 4301/1.

### 1.3 Gear unit selection

Listed in the following table are the service factors according to load combinations and duty life (mechanism classification). These service factors are based on a combination of gear unit selection criteria (operation time, overload, type of motor drive, starts/stops per hour, speed and safety factor) and the specific selection criteria for lifting mechanisms in accordance with FEM 1.00/III'87 and ISO 4301/1.

### 1.3 Auswahlkriterien

Die für die verschiedenen Belastungen und Standzeiten anzusetzenden Betriebsfaktoren (Klassen der Mechanismen) werden in der folgenden Tabelle angegeben. Bei der Ausarbeitung dieser Tabelle wurden die spezifischen, von den Normen FEM 1.00/III'87 und ISO 4301/1 vorgegebenen Kriterien für die Getriebewahl (Standzeit, Überlastungen, Motorisierungstyp, Anlauffrequenz, Drehzahl und Zuverlässigkeit) mit denen der Hubmechanismen kombiniert.

Tab. 1 fs		Durata / Duty life (2) / Standzeit (2)									
Condizioni di carico Load combinations Belastungsbedingungen (1)	fs ≥ Class	not regular use	not regular use	not regular use	not regular use	regular use	regular use	regular use	infrequent use	intensive use	infrequent use
		T0 > 200 h	T1 > 200 h ≤ 400 h	T2 > 400 h ≤ 800 h	T3 > 800 h ≤ 1600 h	T4 > 1600 h ≤ 3200 h	T5 > 3200 h ≤ 6300 h	T6 > 6300 h ≤ 12500 h	T7 > 12500 h ≤ 25000 h	T8 > 25000 h ≤ 50000 h	T9 > 50000 h ≤ 100000 h
L1 Light km ≤ 0.125 k ≤ 0.5	fs ≥ Class	<b>0.8</b> <b>M1</b> (1 Dm)	<b>0.8</b> <b>M1</b> (1 Dm)	<b>0.8</b> <b>M1</b> (1 Dm)	<b>0.8</b> <b>M2</b> (1 Cm)	<b>0.8</b> <b>M3</b> (1 Bm)	<b>0.8</b> <b>M4</b> (1 Am)	<b>0.8</b> <b>M5</b> (2 m)	<b>0.9</b> <b>M6</b> (3 m)	<b>1.1</b> <b>M7</b> (4 m)	<b>1.3</b> <b>* M8</b> (5 m)
	Starts/h	90	90	90	120	150	180	240	300	360	≥ 360
	duty serv	15%	15%	15%	20%	25%	30%	40%	50%	60%	60%
	kz ≥	0.83	0.83	0.83	0.83	0.83	0.83	0.83	0.74	0.60	0.51
L2 Moderate 0.125 < km ≤ 0.25 0.5 < k ≤ 0.63	fs ≥ Class	<b>0.8</b> <b>M1</b> (1 Dm)	<b>0.8</b> <b>M1</b> (1 Dm)	<b>0.8</b> <b>M2</b> (1 Cm)	<b>0.8</b> <b>M3</b> (1 Bm)	<b>0.8</b> <b>M4</b> (1 Am)	<b>0.8</b> <b>M5</b> (2 m)	<b>0.9</b> <b>M6</b> (3 m)	<b>1.1</b> <b>M7</b> (4 m)	<b>1.3</b> <b>* M8</b> (5 m)	<b>1.3</b> <b>* M8</b> (5 m)
	Starts/h	90	90	120	150	180	240	300	360	≥ 360	≥ 360
	duty serv	15%	15%	20%	25%	30%	40%	50%	60%	60%	60%
	kz ≥	0.83	0.83	0.83	0.83	0.83	0.83	0.74	0.60	0.51	0.44
L3 Heavy 0.25 < km ≤ 0.5 0.63 < k ≤ 0.8	fs ≥ Class	<b>0.8</b> <b>M1</b> (1 Dm)	<b>0.8</b> <b>M2</b> (1 Cm)	<b>0.8</b> <b>M3</b> (1 Bm)	<b>0.9</b> <b>M4</b> (1 Am)	<b>0.9</b> <b>M5</b> (2 m)	<b>1</b> <b>M6</b> (3 m)	<b>1.1</b> <b>M7</b> (4 m)	<b>1.3</b> <b>* M8</b> (5 m)	<b>1.6</b> <b>* M8</b> (5 m)	<b>2.0</b> <b>* M8</b> (5 m)
	Starts/h	90	120	150	180	240	300	360	≥ 360	≥ 360	≥ 360
	duty serv	15%	20%	25%	30%	40%	50%	60%	60%	60%	60%
	kz ≥	0.83	0.83	0.83	0.74	0.74	0.67	0.56	0.48	0.44	0.37
L4 Very heavy 0.5 < km ≤ 1 0.8 < k ≤ 1	fs ≥ Class	<b>0.8</b> <b>M2</b> (1 Cm)	<b>0.8</b> <b>M3</b> (1 Bm)	<b>0.9</b> <b>M4</b> (1 Am)	<b>0.9</b> <b>M5</b> (2 m)	<b>1</b> <b>M6</b> (3 m)	<b>1.1</b> <b>M7</b> (4 m)	<b>1.3</b> <b>* M8</b> (5 m)	<b>1.6</b> <b>* M8</b> (5 m)	<b>2.0</b> <b>* M8</b> (5 m)	<b>2.2</b> <b>* M8</b> (5 m)
	Starts/h	120	150	180	240	300	360	≥ 360	≥ 360	≥ 360	≥ 360
	duty serv	20%	25%	30%	40%	50%	60%	60%	60%	60%	60%
	kz ≥	0.83	0.83	0.74	0.74	0.67	0.56	0.48	0.44	0.37	0.33

\* Non fornibili con estremità FD / FD configuration not available for this class / Nicht mit Wellenende FD lieferbar

Note:  
(1)

Notes:  
(1)

Hinweise:  
(1)

$$k = (km)^{1/3} = (\sum_{i=1...n} ((\frac{Pi}{P_{max}})^3 \cdot (\frac{ti}{T})))^{1/3}$$

- k: fattore di spettro equivalente medio.
- km: fattore di spettro.
- ti: durata media di ciascun livello di carico (i = 1...n).
- T: durata totale di uso.
- Pi: ampiezza di ciascun livello di carico.
- P<sub>max</sub>: ampiezza del max livello di carico.
- L1: meccanismi soggetti solitamente a bassi carichi e raramente al max carico.
- L2: meccanismi soggetti solitamente a carichi moderati e raramente al max carico.
- L3: meccanismi soggetti normalmente a carichi pesanti e frequentemente al max carico.
- L4: meccanismi soggetti regolarmente al max carico.

- k: mean equivalent load spectrum factor.
- km: load spectrum factor.
- ti: average duration of each load (i = 1...n).
- T: total duty life.
- Pi: duration (portion of spectrum) of each load.
- P<sub>max</sub>: duration of full load (rated capacity).
- L1: Usually light load, occasional full load.
- L2: Usually moderate load, occasional full load.
- L3: Usually heavy load, frequently full load.
- L4: Usually full load.

- k: Äquivalenter mittlerer Spektrumsfaktor.
- km: Spektrumsfaktor
- ti: durchschnittliche Dauer/Belastungsniveau (i = 1...n).
- T: Gesamte Einsatzdauer.
- Pi: Amplitude/ Belastungsniveau
- P<sub>max</sub>: Amplitude des max. Belastungsniveau
- L1: Normalerweise unter niedriger Belastung und nur selten unter max. Belastung stehende Mechanismen.
- L2: Normalerweise unter durchschnittlicher Belastung und selten unter max. Belastung stehende Mechanismen.
- L3: Normalerweise unter schweren Belastung und häufig unter max. Belastung stehende Mechanismen.
- L4: Regulär unter max. Belastung stehende Mechanismen.

**1.3 Criteri di selezione**

(2) Le durate sono teoriche convenzionali, non possono essere prese come garanzia e possono essere ricavate dall'utilizzazione media giornaliera, dal n° di giorni lavorativi e dagli anni previsti di funzionamento.

(3) I fattori di servizio fs indicati sono validi solo per apparecchi di sollevamento tengono conto del n° di avviamenti max indicato e di una coppia max sul riduttore durante gli intervalli di avviamento e frenatura T<sub>2max</sub>, limitata dal fattore di picco kz secondo quanto specificato al punto Verifiche.  
Per la selezione di riduttori per le traslazioni e le rotazioni di gru e carrelli fare riferimento alle sezioni RXP e RXO.

(4) Nel caso in cui  $Fr_2 \leq (Fr_{2max} / 2)$  si può considerare:  
L3-T8, L4-T7  $fs \geq 1.3$ ;  
L3-T9, L4-T8  $fs \geq 1.6$ ;  
L4-T9  $fs \geq 1.8$

**1.3 Gear unit selection**

(2) *Duty life means projected equipment life calculated on the basis of average daily operating time, number of working days and expected service life in years according to rating conventions and no warranty is implied or given.*

(3) *Service factors fs are valid for lifting equipment only; they are based on the max starts per hour indicated in the table and consider a max torque T<sub>2max</sub> at gear unit during starting and braking up to a limit imposed by peak factor kz as outlined at paragraph Verification.*  
*Gear unit selection for track and slew drive applications in cranes and trolleys is discussed in sections RXP and RXO.*

(4) *If  $Fr_2 \leq (Fr_{2max} / 2)$ , then:*  
L3-T8, L4-T7  $fs \geq 1.3$ ;  
L3-T9, L4-T8  $fs \geq 1.6$ ;  
L4-T9  $fs \geq 1.8$

**1.3 Auswahlkriterien**

(2) Bei den Angaben der Standzeiten handelt es sich um herkömmliche theoretische Werte, die daher nicht als Garantien stehen. Sie können aus dem durchschnittlichen täglichen Einsatz, der Anzahl der Arbeitstage und den für den Betrieb vorgesehenen Jahren errechnet werden.

(3) Die angegebenen Betriebsfaktoren fs sind nur für einen Einsatz an Hubvorrichtungen gültig, dabei wird die angegebene max. Anzahl der Anläufe und ein max. Drehmoment des Getriebes während der Anläufe und Bremsungen T<sub>2max</sub> berücksichtigt, das vom Spitzenfaktor kz gemäß Angaben unter dem Punkt „Überprüfungen“ eingeschränkt wird.  
Bei der Wahl der für einen Verfah- und Rotationsbetrieb von Kränen vorgesehenen Getriebe ist Bezug auf die Anschnitte RXP und RXO zu nehmen.

(4) Im Fall, in dem  $Fr_2 \leq (Fr_{2max} / 2)$  ist kann wie folgt berücksichtigt werden:  
L3-T8, L4-T7  $fs \geq 1.3$ ;  
L3-T9, L4-T8  $fs \geq 1.6$ ;  
L4-T9  $fs \geq 1.8$



**f<sub>n</sub>**

Fattore correttivo delle prestazioni  
*Input speed factor*  
*Korrekturfaktor der Leistungen*

Fattore correttivo delle prestazioni nominali per tenere conto delle velocità in entrata  $n_1 > 1450 \text{ min}^{-1}$

*This correction factor is used to adjust performance ratings to account for input speeds  $n_1 > 1450 \text{ min}^{-1}$*

Korrekturfaktor der Nennleistungen unter Berücksichtigung der Eingangsdrehzahlen  $n_1 > 1450 \text{ min}^{-1}$

n <sub>1</sub> [min <sup>-1</sup> ]	i <sub>N</sub> ≤ 8		8 < i <sub>N</sub> < 80		i <sub>N</sub> ≥ 80	
	T <sub>N</sub>	P <sub>N</sub>	T <sub>N</sub>	P <sub>N</sub>	T <sub>N</sub>	P <sub>N</sub>
2750	0.82	1.56	0.90	1.71	1.00	1.90
2400	0.85	1.41	0.92	1.52	1.00	1.66
2000	0.90	1.24	0.94	1.30	1.00	1.38
1750	0.94	1.13	0.97	1.17	1.00	1.21
1450	1.00	1.00	1.00	1.00	1.00	1.00

**1.3 Criteri di selezione**

**1.3 Gear unit selection**

**1.3 Auswahlkriterien**

<p><b>Dati di ingresso:</b></p> <ol style="list-style-type: none"> <li>1) Tipologia</li> <li>2) F: portata (kg)</li> <li>3) <math>i_e</math>: riduzione esterna (dovuta al numero dei tiri)</li> <li>4) V: velocità di sollevamento (m/min)</li> <li>5) <math>\eta_e</math>: rendimento esterno</li> <li>6) D: diametro del tamburo (mm)</li> <li>7) Classe (M,L,T) dell'apparecchio di sollevamento</li> </ol>	<p><b>Input data:</b></p> <ol style="list-style-type: none"> <li>1) Type</li> <li>2) F: capacity (kg)</li> <li>3) <math>i_e</math> external reduction (number of falls)</li> <li>4) V: lifting speed (m/min)</li> <li>5) <math>\eta_e</math> external efficiency</li> <li>6) D: drum diameter (mm)</li> <li>7) Lifting equipment class (M,L,T)</li> </ol>	<p><b>Eingabedaten:</b></p> <ol style="list-style-type: none"> <li>1) Typologie</li> <li>2) F: Tragfähigkeit (kg)</li> <li>3) <math>i_e</math> externe Reduzierung (durch Zuganzahl)</li> <li>4) V: Hubgeschwindigkeit (m/min)</li> <li>5) <math>\eta_e</math> externer Wirkungsgrad</li> <li>6) D: Trommeldurchmesser (mm)</li> <li>7) Klasse (M,L,T) des Hebegeräts</li> </ol>
---	---	--

**Fattori di servizio:**  
fs da tabella 1  
fn da tabella 2  
(solo nel caso di riduttore senza differenziale)

**Service factors:**  
fs from table 1  
fn from table 2  
(only for gear unit without differential unit)

**Betriebsfaktoren:**  
fs aus Tabelle 1  
fn aus Tabelle 2  
(nur im Fall des Getriebes ohne Differential)

Momento torcente sul tamburo  
Torque on drum  
Drehmoment an Trommel

$$T_2 = \frac{F \cdot D}{\eta_e \cdot i_e \cdot 204} \text{ [Nm]}$$

Velocità angolare del tamburo  
Drum angular speed  
Winkelgeschwindigkeit der Trommel

$$n_2 = \frac{i_e \cdot V \cdot 318}{D} \text{ [min}^{-1}\text{]}$$

$$T_2 \cdot \frac{fs}{fn} < T_N$$

Vedere tabelle prestazioni; selezionare grandezza riduttore  
See rating tables; select gear unit size  
Siehe Tabelle "Leistungen"; Getriebebaugröße wählen

RXP RXO - RXV RXP3/E

Rapporto di trasmissione  
Gear ratio  
Übersetzungsverhältnis

$$i = \frac{n_1}{n_2}$$

Potenza motrice necessaria  
Power required to drive load  
Erforderliche Antriebsleistung

$$P_1 = \frac{T_2 \cdot n_2}{9550 \cdot \eta} \text{ [kW]}$$

Rendimento riduttore  $\eta$   
Gearbox efficiency  $\eta$   
Wirkungsgrad des Getriebes

	RX	RX + E
RXP3	0.94	0.92
RXO2	0.93	—
RXO3	0.91	—

- GSM\_mod.CT03**
- GSM\_mod.CT03**
- GSM\_mod.CT05**



Verifiche  
Verification  
Kontrollen

**Selezione grandezza differenziale**  
Select differential unit size  
Wahl der Differentialgröße

$P_1 \leq P_{ND}$  OR  $T_1 \leq T_{1ND}$

size E	70	100	125	160	180	225
$P_{ND}$ [kW] (1450 min <sup>-1</sup> )	7.5	15	30	55	75	200
$T_{1ND}$ [Nm]	49	99	198	362	494	1317

	E70	E100	E125	E160	E180	E225
RXP3 802						
RXP3 804						
RXP3 806						
RXP3 808						
RXP3 810						
RXP3 812						
RXP3 814						
RXP3 816						
RXP3 818						
RXP3 820						
RXP3 822						
RXP3 824						

**Selezione potenza motore per velocità secondarie**  
Select motor capacity to suit second speed requirement  
Wahl der Motorleistung für Sekundärdrehzahlen

$P_{II} = P_1 \cdot k_2$  [kW]

	E70 - E100 - E125 - E160						
$i_{II/II}$	3.3	5	6.6	9.2	13.1	16.1	18.4*
$k_2$	0.360	0.244	0.187	0.146	0.106	0.091	0.080
	E180 - E225						
$i_{II/II}$	4	5	6	10	13	15	19
$k_2$	0.282	0.244	0.204	0.135	0.104	0.090	0.075

\* Rapporto non standard su E/100. (A richiesta sono disponibili altri rapporti)  
\* Ratio not standard on E/100. (Other ratios available at request)  
\* Übersetzung kein Standard auf E/100. (Auf Anfrage sind weitere Übersetzungen erhältlich)

Fine selezione  
End of selection  
Auswahlabschluss

Verifiche  
Controls  
Kontrollen



### 1.4 Verifiche

- 1) Compatibilità dimensionale con ingombri disponibili (es diametro del tamburo) e delle estremità d'albero con giunti, dischi o pulegge.
- 2) Compatibilità del rapporto selezionato con l'esecuzione albero cavo.
- 3) Compatibilità geometrica come da tabella in designazione.
- 4) Verifica posizione di montaggio.
- 5) Massimo sovraccarico.

### 1.4 Verification

- 1) *Ensure that dimensions are compatible with space constraints (for instance, drum diameter) and shaft ends are compatible with any couplings, discs or pulleys to be used.*
- 2) *Ensure that selected ratio is available for the hollow shaft configuration.*
- 3) Check geometric compatibility as per designation table;
- 4) *Check mounting position.*
- 5) *Maximum overload.*

### 1.4 Überprüfungen

- 1) Compatibilità der Abmessungen mit verfügbaren Maßen (z.B. Trommeldurchmesser) und der Wellenenden mit den Kupplungen, Scheiben oder Riemenscheiben.
- 2) Kompatibilität des gewählten Übersetzungsverhältnisses mit der Ausführung der Hohlwelle.
- 3) Geometrische Kompatibilität gemäß Bezeichnungstabelle.
- 4) Überprüfung der Einbaulage.
- 5) Max. Überlastung.



$$T_{2max} \leq 2 \times T_N \text{ [Nm]}$$

Nel caso di frenature e/o avviamenti  $T_{2max}$  può essere considerata come quella parte della coppia accelerante ( $T_{2acc}$ ) o decelerante ( $T_{2dec}$ ) che passa attraverso l'asse lento del riduttore:

*For braking and/or starting,  $T_{2max}$  may be considered as that portion of acceleration ( $T_{2acc}$ ) or deceleration torque ( $T_{2dec}$ ) passing through the gear unit output (low speed) shaft:*

Bei Bremsungen und/oder Anläufen kann  $T_{2max}$  als der Teil des Beschleunigungsmoments ( $T_{2acc}$ ) oder Abbremsmoment ( $T_{2dec}$ ), der durch die Abtriebsachse des Getriebes läuft, angesehen werden:

Avviamento

Starting

Anlauf

$$T_{2max} = T_{2acc} = \left( (0.45 \cdot (T_{1s} + T_{1max}) \cdot ir \cdot \eta) - T_2 \right) \cdot \left( \frac{J}{J + J_0 \cdot \eta} \right) + T_2 \text{ [Nm]}$$

Frenatura

Braking

Bremsung

$$T_{2max} = T_{2dec} = \left( \left( \frac{T_{1f} \cdot ir}{\eta} \right) - T_2 \right) \cdot \left( \frac{J}{J + \frac{J_0}{\eta}} \right) + T_2 \text{ [Nm]}$$

dove:

- J: momento d'inerzia della macchina e del riduttore ridotto all'asse motore ( $\text{kgm}^2$ )
- $J_0$ : momento d'inerzia delle masse rotanti sull'asse motore ( $\text{kgm}^2$ )
- $T_{1f}$ : coppia frenante dinamica (Nm)
- $T_{1s}$ : coppia motrice di spunto (Nm)
- $T_{1max}$ : coppia motrice max (Nm)

Where:

- J: *machine and gear unit inertial load reflected to motor shaft ( $\text{kgm}^2$ )*
- $J_0$ : *inertial load of rotating parts at motor shaft ( $\text{kgm}^2$ )*
- $T_{1f}$ : *dynamic braking torque (Nm)*
- $T_{1s}$ : *starting torque (Nm)*
- $T_{1max}$ : *max drive torque (Nm)*

Hier ist:

- J: An der Motorachse reduziertes Trägheitsmoment der Maschine und des Getriebes ( $\text{kgm}^2$ )
- $J_0$ : Trägheitsmoment der an der Motorachse drehenden Massen ( $\text{kgm}^2$ )
- $T_{1f}$ : dynamisches Bremsmoment (Nm)
- $T_{1s}$ : Anlaufantriebsdrehmoment (Nm)
- $T_{1max}$ : Max. Antriebsmoment (Nm)

**N.B Il differenziale E70 consente un funzionamento continuo.**  
Per applicazioni di questo tipo consultare il ns. servizio tecnico commerciale.

**NOTE Differential unit E70 allows for continuous operation.**  
Please consult our Sales Engineers when selecting units for continuous duty applications.

**HINWEIS: Das Differential E70 ermöglicht einen Dauerbetrieb.** Für Applikationen dieser Art Beratung bei unserem Technischen Kundendienst einholen.

Nel caso di scelta di riduttori ad assi paralleli o ortogonali senza differenziale attenersi alle ulteriori verifiche riportate nelle sezioni di pertinenza (RXP, RXO) catalogo **GSM\_mod. CT03.**

*When selecting in-line helical or helical bevel gear units without differential unit, follow the verification procedures outlined in the relevant sections (RXP, RXO) Catalogue **GSM\_mod. CT03.***

Werden Parallelachsen- oder Kegelstrinradgetriebe ohne Differential gewählt, die weiteren Überprüfungen und Kontrollen vornehmen, die in den entsprechenden Abschnitten (RXP, RXO) Kataloge **GSM\_mod. CT03** angegeben werden.

1.4 Verifiche

6) Verifica carichi radiali e assiali

**RX 800 Series**

Qualora il collegamento tra riduttore e macchina motrice o operatrice sia effettuato con mezzi che generano carichi radiali sull'estremità d'albero veloce o lento, occorre fare le seguenti verifiche.

Calcolo Fr<sub>2</sub>'

I carichi massimi Fr<sub>2</sub> sono calcolati con Fs=1 ed a una distanza dalla battuta dell'albero di 0.5 S se albero veloce o 0.5 R se albero lento.

Tali valori sono riportati nelle tabelle delle prestazioni; per esecuzione Fn vedere sezione 1.12.

Per distanze variabili tra 0 e una distanza "X" bisogna utilizzare le tabelle seguenti: Fr<sub>2</sub> con coefficiente A. Fr<sub>2</sub> con coefficiente C nel caso di flange FD.

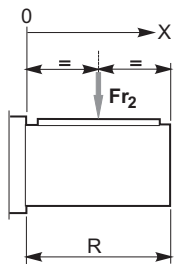

$$Fr_2 = Fr_2 \cdot \left( \frac{A}{A + X - \frac{R}{2}} \right)$$

$$Fr_2 = Fr_2 \cdot C$$

use only for FD, FDn execution  
use only for FD, FDn configuration

**A - C**

Coefficienti correttivi del carico radiale di catalogo in uscita Fr<sub>2</sub> in funzione della distanza dalla battuta  
Load location factors to adjust output OHL capacity rating Fr<sub>2</sub> based on distance from shoulder  
Korrekturkoeffizient der Radialkraft am Abtrieb Fr<sub>2</sub> gemäß Katalog in Abhängigkeit des Ansatzabstands

	RXP											
	802	804	806	808	810	812	814	816	818	820	822	824
<b>A</b>	99	109	124	137	156	175	200	225	236	261	294	331
<b>C</b>	1.32	1.35	1.39	1.46	1.49	1.43	1.32	1.32	1.33	1.35	1.32	—

Calcolo Fr

Per calcolare il carico Fr agente sull'albero lento diamo formule approssimate per alcune trasmissioni più comuni, per la determinazione del carico radiale su albero veloce o lento.

Fr calculation Fr

Use the formula and the approximate factors for input or output overhung load determination referred to the most common drive members to calculate Fr load at output shaft.

Berechnung der Fr

Für die Berechnung der an der Abtriebswelle wirkenden Belastungen Fr geben wir approximative Formeln an, die für einige der allgemeinen Antriebsformen zum Bestimmen der auf die An- oder Abtriebswelle einwirkenden Radialkraft verwendet werden können.

1.4 Verification

6) Overhung and thrust load verification

When a gear unit is connected to prime mover or driven machine using overhung drive members that place a radial load on input or output shaft end, check the following loads.

Fr<sub>2</sub>' calculation

Load capacity ratings Fr<sub>2</sub> consider a service factor Fs=1 and load location at a distance from shaft shoulder of 0.5 S for input shafts or 0.5 R for output shafts.

These values are reported in the rating tables; for configuration Fn look section 1.12.

Where load is applied at a distance from shoulder between 0 and an "X" distance, refer to the following tables:

Fr<sub>2</sub> with load location factor A.

Fr<sub>2</sub> with load location factor C if an FD flange is used.

1.4 Überprüfungen

6) Überprüfung der Radial- und Axialkräfte

Erfolgt die Verbindung zwischen Getriebe und Kraft- oder Arbeitsmaschine mit Vorrichtungen, die Radialkräfte auf das Ende der Antriebs- oder Abtriebswelle ausüben, sind folgende Überprüfungen erforderlich.

Berechnung von Fr<sub>2</sub>'

Die maximalen Belastungskräfte Fr<sub>2</sub> werden mit Fs=1 und auf einem Abstand vom Wellenansatz von 0.5 S im Fall der Antriebswelle oder 0.5 R im Fall der Abtriebswelle berechnet.

Diese Werte werden in den Leistungstabellen angegeben; die Werte von Ausführung Fn, können Sie auf 1.12 finden.

Bei zwischen 0 und einer Distanz "X" variierenden Abständen müssen folgende Tabellen verwendet werden:

Fr<sub>2</sub> mit Koeffizient A.

Fr<sub>2</sub> mit Koeffizient C bei FD-Flanschen.

<b>Fr<sub>2</sub></b> [N]	Carico radiale ammissibile su albero uscita alla distanza X	Permissible output shaft OHL at distance X	An Abtriebswelle auf Distanz X zulässige Radialkraft
<b>Fr<sub>2</sub></b> [N]	Carico radiale ammissibile su albero uscita indicato a catalogo	Output shaft OHL capacity as per catalogue rating	An Abtriebswelle gemäß Katalogangaben zulässige Radialkraft
<b>X</b> [mm]	Distanza dalla battuta dell'albero	Distance from shaft shoulder	Distanz vom Wellenansatz
<b>R</b> [mm]	Sporgenza dell'albero uscita	Output shaft projection	Überstand der Abtriebswelle
<b>A</b>	Coefficiente da tabella	Load location factor from table	Koeffizient aus Tabelle
<b>C</b>	Coefficiente da tabella	Load location factor from table	Koeffizient aus Tabelle

1.4 Verifiche

1.4 Verification

1.4 Überprüfungen



$$Fr = k \cdot \frac{T}{d}$$

<b>Fr</b> [N] Carico radiale approssimato <i>Approximate overhung load</i> Approx. Wert - Radialkraft	<b>d</b> [mm] Diametro pulegge, ruote <i>Pulley diameter, wheels</i> Durchmesser Räder, Riemenscheiben	<b>k</b> Fattore di collegamento <i>Connection factor</i> Anschlusswert	<b>T</b> [Nm] Momento torcente <i>Torque</i> Drehmoment
--	--	--	--

k =	7000	5000	3000	2120	2000
Trasmissioni <i>Drive member</i> Antriebe	Ruote di frizione (gomma su metallo) <i>Friction wheel drive (rubber on metal)</i> Kupplungsräder (Gummi auf Metall)	Cinghie trapezoidali <i>V belt drives</i> Keilriemen	Cinghie dentate <i>Toothed belts</i> Zahnriemen	Ingranaggi cilindrici <i>Spur gears</i> Zylinderzahnräder	Catene <i>Chain drives</i> Ketten

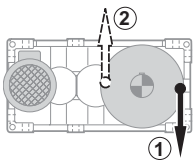

Nel caso di sollevamento con tamburo con tiro verso il basso è preferibile che la fune si avvolga dalla parte opposta al motore (1).  
Nel caso più gravoso del precedente, con tiro verso l'alto, viceversa è preferibile che la fune si avvolga dal lato motore (2).

*In lifting applications using winch drums in a downward pull direction, it is best for the rope to wrap on the side opposite to the motor (1).  
In the more severe case of upward pull direction, the rope should wrap on motor side (2).*

Bei Hebeverfahren mit einer Trommel mit Zugkraft nach unten, sollte das Seil auf der dem Motor (1) entgegen gesetzten Seite aufgerollt werden.  
Im Fall eines härteren Einsatzes als den zuvor genannten, mit Zugkraft nach oben, sollte das Seil dagegen an der Motorseite (2) aufgewickelt werden.

Caso A)

Per carichi radiali minori di 0.25 Fr<sub>2</sub>' è necessario verificare soltanto che contemporaneamente al carico radiale sia presente un carico assiale non superiore a 0.2 volte Fr<sub>2</sub>';

Case A)

*For overhung loads lower than 0.25 Fr<sub>2</sub>', ensure that the thrust load applied simultaneously with OHL is not greater than 0.2 times Fr<sub>2</sub>';*

Fall A)

Bei Radialkräften unter 0.25 Fr<sub>2</sub>' muss nur überprüft werden, dass gleichzeitig mit der Belastung durch die Radialkraft auch eine Axialkraft von nicht mehr als 0.2 Mal Fr<sub>2</sub>' vorliegt.

Caso B)

Per carichi radiali maggiori di 0.25 Fr<sub>2</sub>';  
1) Calcolo abbreviato: Fr (output) < Fr<sub>2</sub>' e che contemporaneamente al carico radiale sia presente un carico assiale non superiore a 0.2 volte Fr<sub>2</sub>';

Case B)

*For overhung loads greater than 0.25 Fr<sub>2</sub>';  
1) Quick calculation method: Fr (output) < Fr<sub>2</sub>' and thrust load applied simultaneously with OHL not greater than 0.2 times Fr<sub>2</sub>';*

Fall B)

Bei Radialkräften über 0.25 Fr<sub>2</sub>':  
1) Verkürzte Berechnungsgleichung: Fr(output)<Fr<sub>2</sub>' und dass gleichzeitig mit der Belastung durch die Radialkraft auch eine Axialkraft von nicht mehr als 0.2 Mal Fr<sub>2</sub>' vorliegt.

2) Calcolo completo per il quale occorre fornire i seguenti dati:

- momento torcente applicato o potenza applicata
- n<sub>2</sub> (giri al minuto dell'albero dell'albero lento)
- carico radiale Fr (direzione, intensità, verso)
- senso di rotazione dell'albero
- grandezza e tipo del riduttore scelto
- tipo olio impiegato e sua viscosità
- esecuzione grafica assi:
- carico assiale presente Fa

2) *For the standard calculation method, the following information is required:*

- *applied torque or power*
- *n<sub>2</sub> (output shaft rpm)*
- *overhung load Fr (orientation, amount of loading, direction)*
- *direction of rotation of shaft*
- *size and type of selected gear unit*
- *oil type and viscosity*
- *shaft arrangement:*
- *actual thrust load Fa*

2) Vollständige Berechnungsgleichung für die folgende Daten erforderlich sind:

- appliziertes Drehmoment oder applizierte Leistung
- n<sub>2</sub> (Drehungen/Minute der Abtriebswelle)
- Radialkraft Fr (Richtung, Intensität, Seite)
- Drehrichtung der Welle
- Baugröße und Typ des gewählten Getriebes
- verwendeter Öltyp und dessen Viskositätsgrad
- grafische Achsausführung
- vorliegende Axialkraft Fa

Consultare il supporto Tecnico per la verifica.

*Please contact our Engineering for a verification.*

Für eine Überprüfung die Technischen Unterlagen konsultieren.

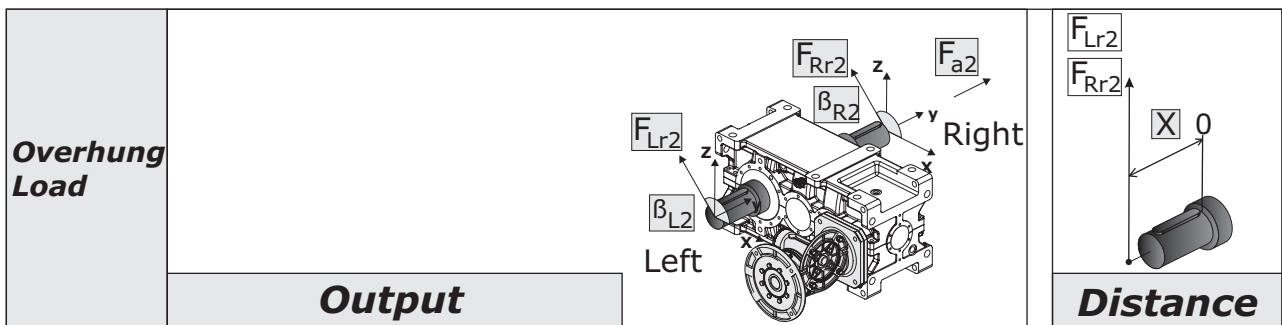
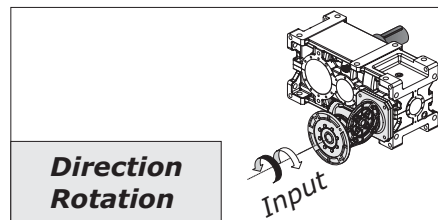
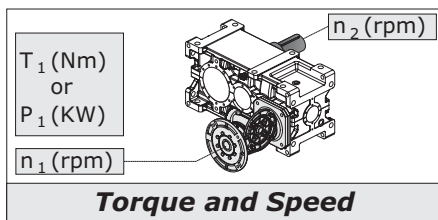

## 1.5 Stato di fornitura

### 1.5.1 Protezione alla corrosione e protezione superficiale

#### General information

GSM propone diverse soluzioni protettive opzionali per motori e riduttori che lavorano in speciali condizioni ambientali.

Le misure protettive sono costituite da:

- Protezione corrosiva e protezione superficiale per motori e riduttori;
- Colore Standard RAL 5010

#### 1.5.1.1 - Protezione Corrosiva

La protezione corrosiva è ottenuta con le seguenti specifiche come standard:

- Le targhette sono realizzate in acciaio inox;
- Applicazione di un prodotto anticorrosivo temporaneo per proteggere le superfici di accoppiamento delle flange e gli alberi uscita.

Nel caso di specifiche richieste è possibile applicare tutte le viti di fissaggio in acciaio inox.

#### 1.5.1.2 - Verniciatura e protezione Superficiale

I riduttori preventivamente sabbiati vengono verniciati con vernice ad alto solido, internamente antiolio ed esternamente con fondo epossidico anticorrosivo di colore grigio o rosso ricoperto da finitura poliuretanica bicomponente di colore Blu RAL 5010 (TYP1).

La protezione ottenuta è idonea a resistere in ambienti mediamente corrosivi, industriali interni ed esterni e consente ulteriori finiture a scelta del cliente.

Nel caso si debbano prevedere impieghi in ambienti industriali più aggressivi o corrosivi o estremi o più genericamente di tipo marino, occorre adottare prodotti adeguati apposti con opportuno ciclo di verniciatura. In questi casi si suggerisce di concordare il ciclo in fase di ordine.

La GSM comunque propone già cicli di verniciatura speciali selezionati per ambienti di questo tipo (TYP2 - TYP3 - TYP4).

## 1.5 Scope of the supply

### 1.5.1 - Corrosion and surface protection

#### General information

GSM offers different protective solutions for motors and gearboxes which work in special weather condition

The protective measures are:

- Corrosion and surface protection for motors and gearboxes;
- Standard color RAL 5010

#### 1.5.1.1 - Corrosion protection

The corrosion protection is the result of the following standard procedures:

- The name plates are made of inox steel;
- An anticorrosive temporary product is applied on the mechanized surfaces of flanges and output shafts

In case of special requests it is possible to use inox steel screws

#### 1.5.1.2 - Painting and surface protection

Gearboxes, after being sand blasted, are painted with a specific paint, which has a double function. On the internal side it works as an anti-oil, while on the external side it works as a grey or red anticorrosive epoxy primer covered by a blue RAL 5010 (TYP 1) bi-component polyurethane finishing paint.

The above mentioned protection is suitable for internal and external industrial environments with corrosive effects on the average. It also gives to the customer the possibility to chose other finishing effects.

In case of use in aggressive or corrosive industrial or sea environments, it is necessary to use special products with the required painting cycle. We suggest you to specify these particular terms with our company.

GSM offers already special painting cycles, which have been created for these kind of environments (TYP2 – TYP3 – TYP 4).

## 1.5 Lieferzustand

### 1.5.1 - Korrosionsschutz und Oberflächenschutz

#### Allgemeine Information

GSM bietet optional verschiedene Schutzmöglichkeiten für Motoren und Getriebe an, die in besonderen Umweltbedingungen arbeiten

Die Schutzmaßnahmen bestehen aus:

- Korrosionsschutz und Oberflächenschutz für Motoren und Getriebe;
- Standardfarbe RAL 5010

#### 1.5.1.1 - Korrosionsschutz

Der Korrosionsschutz ist bei den folgenden Spezifikationen standardmäßig:

- Die Typenschilder sind aus Edelstahl;
- Anwendung eines temporären Antikorrosionsproduktes als Oberflächenschutz für die Flansch und Abtriebswellenverbindungen

Im Falle spezifischer Anfragen können alle Befestigungsschrauben aus Edelstahl verwendet werden.

#### 1.5.1.2 - Lackierung und Oberflächenschutz

Die vorbeugend sandgestrahlten Getriebe werden mit Farbe mit hohem Feststoffgehalt lackiert, innen gegen das Öl und außen gegen Korrosion mit Epoxid in grauer oder roter Farbe. Und werden abschließend mit Bikomponentenpolyurethan in der Farbe blau RAL 5010 (TYP 1) überzogen..

Der erreichte Schutz ist geeignet für Bereiche mit durchschnittlicher Korrosion, für den industriellen Innen- und Außeneinsatz geeignet und erlaubt eine zusätzliche Endbearbeitung gemäß Kundenwunsch.

Sollte der Einsatz in industriellen Bereichen erfolgen, die aggressiver oder korrosiver oder extremer oder allgemein den marinen Bereich betreffen, müssen hierfür geeignete Produkte mit den entsprechenden Lackierzyklen verwendet werden. In diesen Fällen wird vorgeschlagen zuzustimmen.

Die GSM schlägt hier jedoch bereits speziell ausgewählte Lackierzyklen für Bereiche dieser Art vor (TYP2 - TYP3 - TYP4).

1.5 Stato di fornitura

1.5 Scope of the supply

1.5 Lieferzustand

**RX 800 Series**

Protezione superficiale Surface protection	Numero di strati Permutation of layers	Spessore Coat thickness	Adatto per Suitable for
<b>TYP 1</b> "STANDARD"	1x Primer 1x Two-component top coat	Circa/Approx. <b>120 micron</b> A Secco/Dry	1 - Impatto ambientale BASSO - (condizioni ambientali normali) Low environment impact (Normal ambient condition) 2 - Umidità relativa inferiore al 90% Relative humidity below 90 % 3 - Temperatura superficiale massima. 120 °C Surface temperature up to max. 120 °C 4 - Categoria di corrosività " <b>C3-M</b> " (DIN EN ISO 12,944-2) Corrosivity category " <b>C3-M</b> " (DIN EN ISO 12,944-2)
<b>TYP 2</b> Standard Rinforzato Standard Reinforced	1x Primer 1x Two-pack Intermediate 1x Two-pack top coat	Circa/Approx. <b>160 micron</b> A Secco/Dry	1 - Impatto ambientale MEDIO Medium environmental impact 2 - Umidità relativa massima 95 % Relative humidity max. 95 % 3 - Temperatura superficiale massima 120 °C Surface temperature up to max. 120 °C 4 - Categoria di corrosività " <b>C4-M</b> " (DIN EN ISO 12,944-2) Corrosivity category " <b>C4-M</b> " (DIN EN ISO 12,944-2)
<b>TYP 3</b> Industriale Industrial	1x Primer 2x Two-pack Intermediate 1x Two-pack top coat	Circa/Approx. <b>240 micron</b> A Secco/Dry	1 - Impatto ambientale ALTO - Applicazione industriale High environmental impact - Industrial Application 2 - Umidità relativa massima 100 % Relative humidity max. 100 % 3 - Temperatura superficiale massima 120 °C Surface temperature up to max. 120 °C 4 - Categoria di corrosività " <b>C5I-M</b> " (DIN EN ISO 12,944-2) Corrosivity category " <b>C5I-M</b> " (DIN EN ISO 12,944-2)
<b>TYP 4</b> Marino Marine	1x Zinc Primer 2x Two-pack Intermediate 2x Two-pack top coat	Circa/Approx. <b>320 micron</b> A Secco/Dry	1 - Alto impatto ambientale - Applicazione ambiente marino High environmental impact - Marine Application 2 - Umidità relativa massima 100 % Relative humidity max. 100 % 3 - Temperatura superficiale massima 120 °C Surface temperature up to max. 120 °C 4 - Categoria di corrosività " <b>C5M-M</b> " (DIN EN ISO 12,944-2) Corrosivity category " <b>C5M-M</b> " (DIN EN ISO 12,944-2)

A richiesta é possibile fornire ciclo di verniciatura ,schede tecniche dei prodotti utilizzati e report di prova  
 If requested, we can supply you with painting procedures, data sheets of the products which have been used and testing reports  
 Auf Anfrage ist es möglich den Lackierzyklus, technische Leistungsblätter der benutzten Produkte und Testberichte zur Verfügung zu stellen

**OPT2 - Opzioni - Verniciatura**  
**Options - Painting and surface protection**  
**Optionen - Lackierung und Oberflächenschutz**

Serie Series Baureihe	Verniciatura Interna Inner painting Innenlackierung	Verniciatura Esterna Outer painting Außenlackierung		Piani lavorati Machined surfaces Bearbeitete Flächen	Alberi Shafts Wellen
		Tipo e Caratteristiche vernice Paint type and features Lacktyp und -eigenschaften	Verniciabile Can be painted Kann lackiert werden		
<b>TYP 1</b>					
<b>RXP/E</b>	fondo epossidico anticorrosivo di colore grigio o rosso Grey or red anticorrosive epoxy primer Epoxidkorrosionsschutz in grauer oder roter Farbe	ricoperto da finitura poliuretana bicomponente di colore Blu RAL 5010 (TYP1) Covered by a blue RAL 5010 (TYP 1) bi-component polyurethane finishing paint überzogen mit Bikomponentenpolyurethan in der Farbe blau RAL 5010 (TYP 1)	Si	Protetti con prodotto antiruggine. Protected by oxide protectant Mit Rostschutzpaste geschützt.	Protetti con prodotto antiruggine <i>Protected by oxide protectant.</i> Mit Rostschutzpaste geschützt.

**ATTENZIONE**  
 In caso di verniciatura o asportazione del prodotto antiruggine si chiede di porre attenzione alla preventiva protezione:  
 - Delle superfici lavorate, al fine di evitare che una eventuale verniciatura delle stesse pregiudichi il successivo accoppiamento.  
 -Delle tenute e più in generale di ogni parte plastica e di gomma, al fine di non variarne le caratteristiche chimico fisiche pregiudicandone così l'efficienza.  
 -Alla targa di identificazione per evitare la perdita di tracciabilità.  
 -Al tappo sfiato ed al tappo di livello olio, al fine di evitarne l'occlusione.

**ATTENTION**  
 If the product must be painted or cleaning off any antirust paint, protect the machined surfaces and oil seals/gaskets in order to prevent any damage. It is also necessary to protect the identification plate, the oil level plug (if fitted) and the hole in the breather plug (if fitted) against obstruction.

**ACHTUNG**  
 Sollten die Produkte lackiert werden oder Abbau des Rostschutzmittels, muss darauf geachtet werden, dass die bearbeiteten und Dichtflächen dabei geschützt werden, so dass verhindert werden kann, dass die Lackierung die chemisch-physischen Eigenschaften verändert und die Wirkung der Ölabdichtungen einschränkt. In der gleichen Weise und aus gleichem Grund müssen das Typenschild und die Öleinfüllschraube sowie die Bohrung der Entlüftungsschraube (wo vorhanden) geschützt werden.



**1.5 Stato di fornitura**

**1.5 Scope of the supply**

**1.5 Lieferzustand**

**1.5.3 MATERIALI COSTRUTTIVI**

**1.5.3 MATERIAL**

**1.5.3 KOSTRUKTIONSMATERIAL**

**1.5.3.1 Casse - Flange - Coperchi**

**1.5.3.1 Housings - Flanges - Covers**

**1.5.3.1 Gehäuse - Flanschen – Deckel**

Serie Series Baureihe	Per ulteriori informazioni vedere <b>1.6.5</b> For more details, please read <b>1.6.5</b> Sie können Weitere Informationen siehe <b>1.6.5</b>
<b>RXP/E</b>	

**1.5.3.2 Materiale degli anelli di tenuta**

**1.5.3.2 Materials of Seals**



**1.15.2.2 Dichtungstoffe**



Serie Series Baureihe	<b>OPT</b> Opzioni - Materiale degli anelli di tenuta Options - Materials of Seals Optionen - Dichtungstoffe	
	—  (Tenute STANDARD Oil Seals Standard Ölabdichtungen Standard)	.....  Opzioni - Disponibile Options Available Optionen - verfügbar
<b>RXP/E</b>	<b>Per ulteriori informazioni vedere SEZIONE U</b> <b>For more details, please read SECTION U</b> <b>Sie können Weitere Informationen siehe ABSCHNITT U</b>	

**1.5.4 Lubrificazione**

**1.5.4 Lubrication**

**1.5.4 Schmierung**

	<b>OPT1 - Opzioni - Stato fornitura olio</b> Options - Scope of the supply - Options - OIL Optionen - Lieferzustand - Optionen - Öl	
<b>E</b>		Sigla ordine Designation order Bezeichnung Bestellung
	70	<b>INOIL</b>
	100	<b>OUTOIL</b>
	125	
	160	
	180	
225		

	<b>OPT1 - Opzioni - Stato fornitura olio</b> Options - Scope of the supply - Options - OIL Optionen - Lieferzustand - Optionen - Öl	
<b>RXP 800</b>		Sigla ordine Designation order Bezeichnung Bestellung
	all sizes	<b>OUTOIL</b>

**1.5 Stato di fornitura**

**1.5 Scope of the supply**

**1.5 Lieferzustand**

**1.5.4 Lubrificazione**

**1.5.4 Lubrication**

**1.5.4 Schmierung**

**ATTENZIONE:**

Lo stato di fornitura è messo in evidenza con una targhetta adesiva posta sul riduttore.

Verificare la corrispondenza tra stato di fornitura e targhetta adesiva.

**CAUTION:**

*Gearbox state of supply is indicated on a nameplate applied on gearbox.*

*Ensure that nameplate data and state of supply correspond.*

**ACHTUNG:**

Der entsprechende Lieferzustand wird auf einem Aufkleber am Getriebe angegeben. Überprüfen Sie die Übereinstimmung zwischen effektivem Lieferzustand und Aufkleber.



OPT1 - Opzioni - Stato fornitura olio- Options - Scope of the supply - Options - OIL Optionen - Lieferzustand - Optionen - Öl				
Stato fornitura Scope of the supply Lieferzustand	Riduttore - Lubrificazione Gearbox - Lubrication Getriebe - Schmierung	Tipo Type Typ	NOTE Note Hinweis	Targhetta Nameplate Aufkleber
<b>OUTOIL</b>  Riduttore Privo di Lubrificante <i>Gearbox with no lubricant</i> Getriebe ohne Schmiermittel	Si consiglia l'uso di oli a base sintetica PAO. Vedere a tale proposito le indicazioni riportate paragrafo 1.8.  The use of synthetic oil is recommended PAO. see details in paragraph 1.8.  Der Einsatz von synthetischem Öl wird empfohlen PAO. Siehe diesbezüglich die Hinweise im Abschnitt 1.8.		Se richiedi completi di lubrificante, verranno forniti con olio standard - "INOIL_STD"  If customer requests supply of gearbox with lubricant, we shall supply - "INOIL_STD"  Falls diese Getriebe mit Schmiermittelfüllung angefordert werden - "INOIL_STD"	 
<b>INOIL_STD</b>  Riduttore Completo di Lubrificante Standard STM <i>Gearbox with lubricant STM standard</i> Getriebe mit Standard Schmiermittel STM	E70 <b>OMALA S4 WE 320</b>	OilGear_TYPE CLP PG Synthetic <b>PG</b>	—	 
	E100 - E125 - E160 - E180 - E225 <b>AGIP BLASIA 220</b>  RX 800 <b>AGIP BLASIA 220</b>	OilGear_TYPE CLP Mineral		 
<b>INOIL_Food</b>  Riduttore Completo di Lubrificante "ALIMENTARE" <i>Gearbox with lubricant "FOOD-TYPE"</i> Getriebe mit Schmiermittel "LEBENSMITTEL"	RX 800 - E <b>Klüberoil 4 UH1 N 320</b>	OilGear_TYPE CLP HCE Synthetic <b>HCE NSF H1</b>	—	 
<b>ASOIL</b>  Riduttore Completo di Lubrificante Speciale - a richiesta <i>Gearbox with Special lubricant - On request</i> Getriebe mit Sondern-Schmiermittel - Auf Anfrage	A richiesta On request Auf Anfrage	OilGear_TYPE CLP PG Synthetic <b>PG</b>	—	
		OilGear_TYPE CLP HC Synthetic <b>PAO</b>		
		OilGear_TYPE CLP Mineral		
		OilGear_TYPE CLP HCE Synthetic <b>HCE NSF H1</b>		
		Grease		

**Nota campo- ASOIL**

Nella targhetta sono riportate le seguenti informazioni:

- Code\_Plate;
- Sigla lubrificante;
- ISO VG;
- Type DIN;
- NSF;
- Altre prescrizioni.

**Note range-ASOIL**

The type plate contains the following information:

- Code\_Plate
- Lubricant type
- ISO VG
- Type DIN
- NSF
- other details

**Hinweis Bereich-ASOIL**

Auf dem Typenschild finden Sie folgende Informationen:

- Code\_Plate
- Schmiermitteltyp
- ISO VG
- Type DIN
- NSF
- andere Hinweise

**1.5 Stato di fornitura****1.5.4.2 - Lubricazione cuscinetti****Lubrificazione cuscinetti superiori RXP3+E**

In caso di montaggio in posizione M5 ed M6 per le grandezze da 802 a 820 la lubrificazione dei cuscinetti superiori del riduttore ad assi paralleli viene assicurata tramite grasso lunga vita ed anelli nilos. Per le grandezze superiori consultare il ns. servizio tecnico commerciale.

**1.5.4.2.1 - G - (grease)**

Pertanto è stato predisposto un ingrassatore per provvedere all'opportuno ringrassaggio.

**Le Caratteristiche tecniche generali del grasso utilizzato sono:**

- Inspessente: base di Litio Complesso;
- NGLI: 2;
- Olio: HCE - con aditivazione EP di viscosità minima ISO VG 220;
- Additivi: l'olio presente nel grasso deve avere caratteristiche di aditivazione EP;

SPECIFICHE E APPROVAZIONI  
DIN51502: **KP-HCE-2 P-40**

**1.6 Normative applicate****1.6.1 Specifiche prodotti non "ATEX"**

I riduttori della GSM SpA sono organi meccanici destinati all'uso industriale e all'incorporazione in apparecchiature meccaniche più complesse. Dunque non vanno considerati macchine indipendenti per una predeterminata applicazione ai sensi 2006/42/CE, né tantomeno dispositivi di sicurezza.

**1.5 Scope of the supply****1.5.4.2 - Bearing lubrication****RXP3+E upper bearing lubrication**

*In-line helical gear unit sizes 802 through 820 designated for mounting positions M5 and M6 have upper bearings charged with long-life grease and Nilos rings. For larger sizes, please contact our Sales Engineers.*

**1.5.4.2.1 - G - (grease)**

To this end it is provided with a greaser.

**Following are the general technical features of the lubrication grease:**

- Thickener: Complex Lithium-based;
- NGLI: 2;
- Oil: HCE with EP additives with minimum viscosity as per ISO VG 220;
- Additives: the oil in the grease must feature EP additive;

SPECIFICATIONS AND APPROVALS

**1.6 Standards applied****1.6.1 Specifications of non - "ATEX" products**

GSM SpA gearboxes are mechanical devices for industrial use and incorporation in more complex machines. Consequently, they should not be considered neither self-standing machines for a pre-determined application according to 2006/42/CE nor safety devices.

**1.5 Lieferzustand****1.5.4.2 - Schmierung der Abtriebslagerung****Schmierung der obenliegenden Lager RXP3+E**

Bei einer Einbaulage in der Position M5 und M6 wird die Schmierung der oberen Lager des Parallelachsengetriebe bei den Baugrößen 802 bis 820 durch den Einsatz eines "long life"-Fetts mit Nilos-Ringen gesichert. Für darüber liegende Baugrößen ist Beratung bei unseren Technischen Kundendienst einzuholen.

**1.5.4.2.1 - G - (grease)**

Daher wurde ein angemessener Schmiernippel für das Nachschmieren vorgesehen.

**Allgemeine technische Eigenschaften des verwendeten Fetts:**

- Verdickungsmittel: auf Lithiumkomplex;
- NGLI: 2;
- Öl: HCE mit Zusatz von EP mit Mindestviskosität gemäß ISO VG 220;
- Additive: das im Fett enthaltene Öl muss die Eigenschaften der EP Additivierung aufweisen;

SPEZIFIKATIONEN  
DIN51502: **KP-HCE-2 P-40**

**1.6 Angewendete Normen****1.6.1 Spezifikationen für produkte, die nicht der "ATEX"-norm entsprechen**

Bei den Getrieben der GSM SpA handelt es sich um Mechanikorgane, die für den industriellen Einsatz und einen Einbau in komplexere Einrichtungen bestimmt sind. Sie werden deshalb weder unter dem Aspekt unabhängiger, für eine bestimmte Anwendung vorgesehener Maschinen im Sinne der 2006/42/CE, noch als Sicherheitsvorrichtungen berücksichtigt.

1.6 Normative applicate

1.6 Standards applied

1.6 Angewendete Normen

1.6.2 Specifiche prodotti "ATEX"

1.6.2 Specifications of "ATEX" products

1.6.2 Spezifikationen für "ATEX"-produkte

**Campo applicabilità**

La direttiva ATEX (2014/34/UE) si applica a prodotti elettrici e non elettrici destinati a essere introdotti e svolgere la loro funzione in atmosfera potenzialmente esplosiva. Le atmosfere potenzialmente esplosive vengono suddivise in gruppi e zone a seconda della probabilità di formazione. I prodotti GSM sono Conformi alla seguente classificazione:

**Application field**

ATEX set of provisions (2014/34/UE) is referred to electric and non-electric products which are used and run in a potentially explosive environment. The potentially explosive environments are divided into different groups and zones according to the probability of their formation. GSM products are in conformity with following classification:

**Anwendungsbereich**

Die ATEX-Richtlinie (2014/34/UE) wird bei elektrischen und nicht elektrischen Produkten angewendet, die dazu bestimmt sind, in potentiell explosionsfähigen Atmosphären eingesetzt und betrieben zu werden. Die potentiell explosionsfähigen Atmosphären werden in Abhängigkeit der Wahrscheinlichkeit in Gruppen und Zonen unterteilt. Die GSM-Produkte entsprechen der folgenden Klassifizierung:

Type Mark - standard									
Designation Type Mark	Material	Symbol Mark	Group	Category	Symbol Protection	Group Dangerous material	Temperature	Protection level EPL	Use limitation
Gb-4	GAS		II	2G	Exh	IIC	T4	Gb	-
Gb-5							T5*		
Gc-4			II	3G	Exh	IIC	T4	Gc	-
Gc-5							T5*		
Db-4	DUST		II	2D	Exh	IIIC	135 °C	Db	-
Db-5							100 °C*		
Dc-4			II	3D	Exh	IIIC	135 °C	Dc	-
Dc-5							100 °C**		
ACC5	Cooling unit		On request						
ACC6	Lubr. Grease		Lubrication with grease						
ACC7G	Level		On request						
ACC7H	heater		On request						
ACC7I1	Temperature		On request						
ACC7M2	Pressure		On request						

\*) Classe di temperatura ATEX ottenibile a richiesta / ATEX temperature class on request / Auf Anfrage erhältliche ATEX-Temperaturklasse

Type Mark - with limitation						
Limitation	Material	Designation Type Mark	Category	Group Dangerous material	Note	
Products Versions	Versions with compact motor	—	—	—	All versions are excluded from certification	
Accessory Option	Ventilation system And/Or Painting type: TYP3 - TYP4 *	GAS GAS	b_Gb-4 - b_Gb-5 b_Gc-4 - b_Gc-5	Standard	IIB	*For other type painting: Type Mark is Standard On request in available painting type for IIC: TYP3C & TYP4C
	Ventilation system	DUST DUST	b_Db-4-x - b_Db-5-x b_Dc-4-x - b_Dc-5-x			

Nel caso di Classe di temperatura T5 occorre verificare la potenza limite termico declassata;

In case of T5 Class of temperature the extreme down-graded thermic power should be checked.

Bei der Temperaturklasse T5 muss die zurückgestufte thermische Grenzleistung überprüft werden.

In tutti gli altri casi vale la potenza riportata a catalogo prevista per i singoli rapporti con fattore di servizio complessivo dell'applicazione pari a 1 e le considerazioni sul limite termico.

In all the other instances, the power indicated on the catalogue for the single ratios with overall application service factor equal to 1 and the considerations on temperature limits apply.

In den anderen Fällen gilt die im Katalog für die einzelnen Übersetzungsverhältnisse angegebene Leistung mit Betriebsfaktor einschließlich Applikation entsprechend 1 und die Berücksichtigungen im Hinblick auf die thermische Grenzleistung.

I prodotti del gruppo IID (atmosfera polverosa) vengono definiti dalla massima temperatura di superficie effettiva.

The products of the family IID (dust environment) are defined by the max effective surface temperature.

Die der Gruppe IID (Atmosphäre mit staubförmiger Belastung) angehörigen Produkte werden ihrer effektiven maximalen Oberflächentemperatur gemäß definiert.

La massima temperatura di superficie è determinata in normali condizioni di installazione e ambientali (-20°C e +40°C) e senza depositi di polvere sugli apparecchi. Qualunque scostamento da queste condizioni di riferimento può influenzare notevolmente lo smaltimento del calore e quindi la temperatura.

Max surface temperature is determined in standard installation and environmental conditions (-20°C and +40°C) and in absence of dust on product surface. Any other condition will modify the heat dissipation and consequently the temperature.

Die maximale Oberflächentemperatur wird in normalen Einbau- und Umgebungsbedingungen (-20°C und +40°C) und ohne auf den Vorrichtungen vorhandenen Staubablagerungen bestimmt. Jegliche Abweichung von diesen Bezugsbedingungen kann sich erheblich auf die Wärmeableitung bzw. auf die Betriebstemperatur auswirken.

1.6.3. COME SI APPLICA

Al momento di una richiesta di offerta per prodotto conforme a normativa ATEX 2014/34/UE occorre compilare la scheda acquisizione dati ([www.stmspa.com](http://www.stmspa.com)).

1.6.3. HOW IS IT APPLIED

In case of request of offer relating to any product in conformity with the provisions ATEX/2014/34/UE, the specifications paper should be filled in ([www.stmspa.com](http://www.stmspa.com)).

1.6.2. ANWENDUNGSWEISE

Bei einer Angebotsanfrage für der Richtlinie ATEX 2014/34/UE entsprechende Produkte muss das Datenerfassungsformular ([www.stmspa.com](http://www.stmspa.com)) ausgefüllt werden.

- Effettuare le verifiche come prima descritto.
- I riduttori certificati verranno consegnati con:
  - una seconda targhetta contenente i dati ATEX;
  - ove previsto un tappo sfiato, tappo sfiato con molla interna;
  - se rispondente alla classe di temperatura T4 e T5 verrà allegato un indicatore di temperatura (132 °C nel caso di T4 e 99°C rispettivamente per la T5)
  - Indicatore di temperatura : termometro a singolo rilevamento, una volta raggiunta la temperatura indicata si annerisce segnalando il raggiungimento di tale limite.

- Perform the inspections as described above. Certified reducers will be delivered with:
  - a second nameplate containing ATEX data;
  - a breather valve with internal spring, where a breather is needed;
  - if in accordance with classes of temperature T4 and T5, a temperature gauge will be included (132 °C in case of T4 and 99 °C in case of T5).
  - Temperature gauge: single-reading thermometer, it blackens once temperature is reached, pointing out the achievement of that limit.

- Dazu die zuvor beschriebenen Kontrollen vornehmen. Die zertifizierten Getriebe werden wie folgt ausgestattet geliefert:
  - mit einem zweiten Typenschild mit ATEX- Daten;
  - wo vorgesehen, mit einem Entlüftungs- verschluss, Entlüftungsverschluss mit interner Feder;
  - falls der Temperaturklasse T4 und T5 entsprechend, wird eine Temperaturanzeige vorgesehen (132 °C bei T4 und 99°C bei T5)
  - Temperaturanzeige: einzelnes Erfassungsthermometer - bei Erreichen der angegebenen Temperatur wechselt die Farbe zur Anzeige der erreichten Temperatur in Schwarz.



**1.6 Normative applicate****1.6.4 UE Direttive marcatura CE- ISO9001****Direttiva Bassa Tensione 2014/35/UE**

I motoriduttori, motorivii angolari, motovariatori e i motori elettrici GSM sono conformi alle prescrizioni della direttiva Bassa Tensione .

**2014/30/UE Compatibilità elettromagnetica**

I motoriduttori, motoriviiangolari, motovariatori e i motori elettrici GSM sono conformi alle specifiche della direttiva di Compatibilità Elettromagnetica.

**Direttiva Macchine 2006/42/CE**

I motoriduttori, motoriviiangolari, motovariatori e i motori elettrici GSM non sono macchine ma organi da installare o assemblare nelle macchine.

**Marchio CE, dichiarazione del fabbricante e dichiarazione di conformità.**

I motoriduttori, motovariatori e i motori elettrici hanno il marchio CE.

Questo marchio indica la loro conformità alla direttiva Bassa Tensione e alla direttiva Compatibilità Elettromagnetica.

Su richiesta, GSM può fornire la dichiarazione di conformità dei prodotti e la dichiarazione del fabbricante secondo la direttiva macchine.

**ISO 9001**

I prodotti GSM sono realizzati all'interno di un sistema di qualità conforme allo standard ISO 9001. A tal fine su richiesta è possibile rilasciare copia del certificato.

**1.6.5 Normative riferimento Progettazione e Fabbricazione****Ingranaggi**

Gli ingranaggi cilindrici a dentatura elicoidale e le viti senza fine, sono rettificati dopo cementazione, tempra e rinvenimento finale.

**Cuscinetti**

Tutti i cuscinetti sono del tipo a rulli conici o a rulli orientabili, di elevata qualità e dimensionati per garantire una lunga durata se lubrificati con il tipo di lubrificante previsto a catalogo.

**Carcassa**

La carcassa è ottenuta per fusione in GJL 250 UNI EN 1561 o in ghisa a grafite sferoidale

UNI EN 1563 2004 fino alla grandezza 824. Le grandezze in acciaio sono in S275J2 EN UNI 10025 composto elettrosaldato e disteso. I particolari accorgimenti adottati nel disegno della struttura permettono di ottenere un' elevata rigidezza.

**1.6 Standards applied****1.6.4 UE Directives-CE mark-ISO 9001****Directive 2014/35/UE Low VoltageGSM**

geared motors, right angle drives with motor, motovariators and electric motors meet the specification of the low voltage directive.

**2014/30/UE Electromagnetic Compatibility**

GSM geared motors, right angle drives with motor, motovariators and electric motors correspond to the specifications of the EMC directive.

**Machinery Directive 2006/42/CE**

GSM geared motors, right angle drives with motor, motovariators and electric motors are not standalone machines, they are exclusively for installation into a machine or for assembly on a machine.

**CE Mark, Conformity Declarations and Manufacturer's Declaration.**

GSM geared motors, right angle drives with motor, motovariators and electric motors carry the CE Mark.

It indicates conformity to the low voltage directive and to electromagnetic compatibility directive.

On request GSM supplies both the conformity declarations and the manufacturer's declaration according to the machine directive.

**ISO 9001**

GSM products have been designed and manufactured according to ISO 9001 quality system standard.

On request a copy of the certification can be issued.

**1.6.5 Standards applied****Gearing**

Helical gears and worm shafts are case hardened, hardened and tempered and ground finished.

**Bearings**

All bearings are high quality taper or self-aligning roller bearings suitably sized to ensure long service life provided the approved lubricants indicated in this catalogue are used.

**Casing**

Casings up to size 824 are cast from GJL 250 UNI EN 1561 cast iron or from Spheroidal cast iron.

Sizes use casings fabricated from electrically welded stress relieved S275J2 steel EN UNI 10025.

Casing design incorporates special arrangements to provide superior rigidity.

**1.6 Angewendete Normen****1.6.4 UE-Richtlinien - CE-Zeichen - ISO9001****Niederspannungsrichtlinie. 2014/35/UE**

Die Getriebemotoren, Winkelgetriebe, Verstellgetriebe und Elektromotoren der GSM entsprechen den Vorschriften der Niederspannungsrichtlinie.

**2014/30/UE Elektromagnetische Verträglichkeit**

Die Getriebemotoren, Winkelgetriebe, Verstellgetriebe und Elektromotoren der GSM entsprechen den Vorschriften der Richtlinie zur Elektromagnetischen Verträglichkeit.

**Maschinenrichtlinie 2006/42/CE**

Die Getriebemotoren, Winkelgetriebe, Verstellgetriebe und Elektromotoren der GSM sind keine Maschinen sondern Organe, die in Maschinen eingebaut oder an diesen montiert werden.

**CE-Zeichen, Hersteller- und Konformitätserklärung**

Die Getriebemotoren, Verstellgetriebe und Elektromotoren tragen das CE-Zeichen.

Dieses Zeichen weist auf ihre Konformität mit der Niederspannungsrichtlinie und der Richtlinie zur Elektromagnetischen Verträglichkeit hin.

Auf Anfrage kann die GSM die Konformitätserklärung und die Herstellererklärung gemäß Maschinenrichtlinie zu den Produkten liefern.

**ISO 9001**

Die GSM-Produkte werden in einem Qualitätssystem gemäß dem Standard ISO 9001 realisiert. Auf Anfrage kann daher eine Kopie der Zertifizierung geliefert werden.

**1.6.5 Bezugsnormen Entwicklung und Produktion****Zahnräder**

Die das Evolventenprofil der Stirnrädergetriebe mit Schrägverzahnung und die Schnecken werden nach dem Einsatzhärten, dem Abschrecken und dem

**Lager**

Bei allen Lagern handelt es sich um hochqualitative Kegelrollenlager mit orientierungsfähigen Rollen und in Maßen, die so ausgelegt sind, dass sie bei Einsatz der gemäß Katalogangaben vorgesehenen Schmiermittel eine lange Lebensdauer garantieren.

**Gehäuse**

Die Gehäuse der Getriebe bis Baugröße 824 werden im Gussverfahren aus GJL 250 UNI EN 1561 oder Sphäroguss UNI EN 1563 2004 gewonnen.

Die Baugrößen von Stahl werden aus elektroverschweißtem und entspanntem S275J2 EN UNI 10025 realisiert.

Die besonderen beim Entwurf der Struktur berücksichtigten Vorkehrungen verleihen ihr eine besondere Steifheit.



**1.6 Normative applicate****Alberi**

Gli alberi lenti sono verificati a flesso-torsione con elevato coefficiente di sicurezza. Le estremità d'albero cilindriche sono secondo UNI 6397-68, DIN 748, NF E 22.051, BS 4506-70, ISO/R 775-69, escluso corrispondenza R-S, con foro filettato in testa secondo DIN 1414. Linguetta secondo UNI 6604-69, DIN 6885 BI, 1-68, NF E 27.656 22.175, BS 4235.1-72, ISO/R 773-69 escluso corrispondenza I.

Tutti i prodotti della GSM sono progettati nel rispetto delle seguenti normative:

**Calcolo degli ingranaggi e cuscinetti**

ISO 6336 - ISO10400 - DIN3991  
La capacità di carico è stata calcolata a pressione superficiale e a rottura secondo la normativa ISO 6336 - ISO10400 - DIN3991 ( a richiesta sono possibili verifiche secondo le norme AGMA 2001-C95 e AGMA 2003).

**BS 721**

Calcolo della capacità di carico delle viti e delle corone elicoidali.

**ISO 281**

Calcolo della durata a fatica dei cuscinetti volventi.

**Alberi****DIN 743**

Calcolo della durata a fatica degli alberi

**Materiali****EN 10084**

Acciaio da cementazione per ingranaggi e viti senza fine.

**EN 10083**

Acciaio da bonifica per alberi uscita tipo - **N-D-FD**  
**UB-B** - fino alla grandezza 816.

**EN UNI 10025 - Acciaio****Casse****Alberi uscita tipo - C-CD**

**UB-B** - dalla grandezza maggiore 816.

**UNI EN 1982 - UNI 5274**

Bronzo per corone elicoidali.

**UNI EN 1706**

Alluminio e leghe di Alluminio

**UNI EN 1561**

Fusioni in ghisa grigia.

**UNI EN 1563 2004**

Getti di ghisa a grafite sferoidale

**UNI 3097**

Acciaio per cuscinetti per piste rotolamento

**1.6 Standards applied****Shafts**

*Output shafts are calculations incorporate a high safety factor and are validated by bending and torsional stress analyses. Cylindrical shaft ends are in accordance with UNI 6397-68, DIN 748, NF E 22.051, BS 4506-70, ISO/R 775-69, excluding section R-S, with centre tapped hole at shaft end to DIN 1414. Keys are in accordance with UNI 6604-69, DIN 6885 BI, 1-68, NF E 27.656 22.175, BS 4235.1-72, ISO/R 773-69 excluding section I.*

*All GSM products are designed following these standards:*

**Calculation of gearboxes and bearings**

ISO 6336 - ISO10400 - DIN3991  
*The load capacity of gear sets is calculated at contact and root bending stress in accordance with standard ISO 6336 - ISO10400 - DIN3991*  
- (gears can be rated to AGMA 2001-C95 and AGMA 2003 on request).

**BS 721:**

Calculation of load capacity for worm gearing.

**ISO 281:**

Rolling bearings — Dynamic load ratings and rating life

**Shafts****DIN743**

Shafts — Dynamic load ratings and rating life

**Materials****EN 10084**

Case hardening steels for gears and worms

**EN 10083**

Quenched and Tempered Steels for shafts  
**N-D-FD**  
**UB-B** up to size 816.

**EN UNI 10025 - Steel****Casing****Output shafts type - C-CD**

**UB-B** from the largest size 816.

**UNI EN 1982 - UNI 5274**

Copper for helical worm-gears

**UNI EN 1706**

Aluminium alloy

**UNI EN 1561**

Grey iron casting

**UNI EN 1563 2004**

Spheroidal cast iron

**UNI 3097**

Ball and roller bearing steel

**1.6 Angewendete Normen****Wellen**

Die Abtriebswellen werden unter Berücksichtigung eines hohen Sicherheitskoeffizienten auf Biegung-Windung getestet. Die Enden der zylindrischen Wellen entsprechen den Normen UNI 6397-68, DIN 748, NF E 22.051, BS 4506-70, ISO/R 775-69, ausgenommen Zuordnung R-S, mit Gewindebohrung in der Wellenspitze DIN 1414. Die Federkeile entsprechen UNI 6604-69, DIN 6885 BI, 1-68, NF E 27.656 22.175, BS 4235.1-72, ISO/R 773-69, ausgenommen Zuordnung I.

Alle Produkte der GSM werden unter Einhaltung folgender Normen entwickelt:  
**Berechnung der Zahnräder und Lager**

ISO 6336 - ISO10400 - DIN3991  
Die Belastbarkeit wurde auf Oberflächendruck und Bruch der Richtlinie ISO 6336 - ISO10400 - DIN3991 - gemäß berechnet (auf Anfrage können Überprüfungen den Normen AGMA 2001-C95 und AGMA 2003 gemäß vorgenommen werden).

**BS 721**

Berechnung der Belastungsfähigkeit der Schnecken und Schrägzahnräder.

**ISO 281**

Berechnung der Belastungsdauer der Wälzlager.

**Wellen****DIN743**

Berechnung der Belastungsdauer der Wellen.

**Material****EN 10084**

Einsatzstahl für Zahnräder und Schnecken.

**EN 10083**

Vergütungsstahl für Wellen - typ  
**N-D-FD**  
**UB-B** - bis zur Größe 816.

**EN UNI 10025 - Stahl****Gehäuse****Wellen typ - C-CD**

**UB-B** von der größten Größe 816

**UNI EN 1982 - UNI 5274**

Bronze für Schrägzahnräder

**UNI EN 1706**

Aluminium und Aluminiumlegierungen

**UNI EN 1561**

Grauguss-Legierungen

**UNI EN 1563 2004**

Sphäroguss

**UNI 3097**

Stahl für Lagergleitbahnen

1.7 Designazione

1.7 Designation

1.7 Bezeichnung

<b>CODE:</b> Example of Order	<b>RX</b>	<b>P</b>	<b>3</b>	<b>802</b>	<b>ABU</b>	<b>40.2</b>	<b>E100</b>	<b>-</b>
<b>WEB:</b> Reference Designation	Maschine 00-M	Centerline Orientation 01-CO	N° of reductions 02-NOR	Size 03-SIZE	Shaft arrangement 04-SA	Reduction ratio 05-IR	Differential unit size 06 DUSIZE	Housing material 07-CM

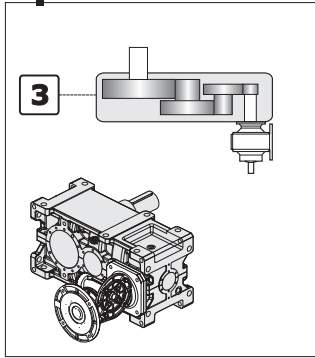
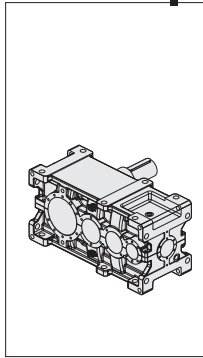

- 802
- 804
- 806
- 808
- 810
- 812
- 814
- 816
- 818
- 820
- 822
- 824

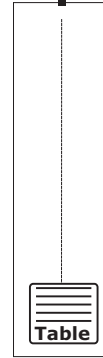

- E70
- E100
- E125
- E160
- E180
- E225

- 
- GS
- A

<b>A M1S</b> 	<b>AUD M1S</b> 	<b>ABU M1S</b> 	<ul style="list-style-type: none"> <li>A</li> <li>AUD</li> <li>ABU</li> </ul>	
<b>B M1D</b> 	<b>BUS M1D</b> 	<b>BBU M1D</b> 		<ul style="list-style-type: none"> <li>B</li> <li>BUS</li> <li>BBU</li> </ul>
<b>C1 M1S</b> 	<b>C2 M1D</b> 			
<b>C1S M1S</b> 	<b>C2S M1D</b> 		<ul style="list-style-type: none"> <li>C1S</li> <li>C2S</li> </ul>	
<b>C1D M1S</b> 	<b>C2D M1D</b> 	<b>RXP3-E</b>  <b>800 Series</b>	<ul style="list-style-type: none"> <li>C1D</li> <li>C2D</li> </ul>	

1.7 Designazione

1.7 Designation

1.7 Bezeichnung



<b>N</b>	<b>M1</b>	<b>-</b>	<b>E</b>	<b>9.2</b>	<b>100</b>	<b>PAM</b>	<b>100</b>	<b>D</b>	<b>ECE</b>	<b>-</b>	<b>-</b>	<b>RXP3 802</b>	<b>M1S</b>	<b>1</b>	<b>-</b>
----------	-----------	----------	----------	------------	------------	------------	------------	----------	------------	----------	----------	-----------------	------------	----------	----------

Output Shaft 08-OS	Mounting positions 09-MP	Options 10-OPT	Differenzial "Maschine" 11-EM	Maximum to minimum speed ratio 12-SRIR	Differenzial size 13-ESIZE	Input Version Main 14-IVM	Input Shaft Main 15-ISM	IEC type and Input Shaft Main 16-IECTM	Input Version Secondary 17-IVS	Input Shaft Secondary 18-ISS	IEC type and Input Shaft Secondary 19-IECTS	Coupled gear unit RXP3 20-RSIZE	Mounting Version 21-MV	Position Terminal Box Main 22-PMTM	Position Terminal Box Secondary 23-PMTS
-----------------------	-----------------------------	-------------------	----------------------------------	---	-------------------------------	------------------------------	----------------------------	---	-----------------------------------	---------------------------------	--	------------------------------------	---------------------------	---------------------------------------	--

**M1**  
**M2**  
**M3**  
**M4**  
**M5**  
**M6**

**U**

70  
100  
125  
160  
180  
225

**M**

**S**

RXP3 802  
---  
RXP3 824

**1**  
**2**  
**3**  
**4**

**1**  
**2**  
**3**  
**4**

**3.3**  
**5**  
**6.6**  
**9.2**  
**13.1**  
**16.1**  
**18.4**

E70  
E100  
E125  
E160

**4**  
**5**  
**6**  
**10**  
**13**  
**15**  
**19**

E180  
E225

**Example for Shaft arrangement "B"**

**B** **M1D**

**M2D**  
**M3D**  
**M4D**  
**M1S**  
**M2S**  
**M3S**  
**M4S**

**N**

**D**

**FD**

**Fn**

**C**

**UB**

**B** Not supplied

**CD**

**1.7 Designazione**

**1.7 Designation**

**1.7 Bezeichnung**

00 M - Macchina

M - Maschine

M - Getriebe

**RX**

01 CO - Posizione Assi

CO - Centerline Orientation

CO - Bauform getriebestufen

**P**

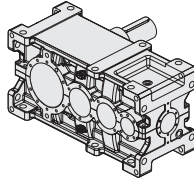

02 NOR - N° Stadi

NOR - N° of reductions

NOR - N° Anzahl der stufen

3

03 SIZE - Grandezza

SIZE - Size

SIZE - Größe

	802	804	806	808	810	812	814	816	818	820	822	824
RXP3												

04 SA - Esecuzione grafica

SA - Shaft arrangement

SA - Grafische Ausführung

04 - SA		
A	AUD	ABU
B	BUS	BBU
C1	C2	
C1D	C1S	
C2D	C2S	

**A M1S**

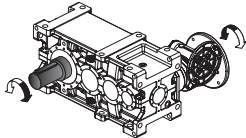

**AUD M1S**

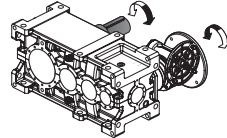

**ABU M1S**

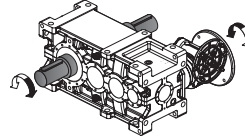

**B M1D**

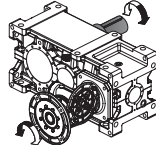

**BUS M1D**

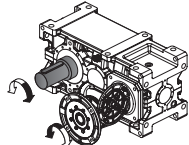

**BBU M1D**

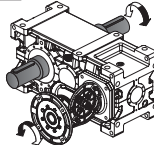

**C1 M1S**

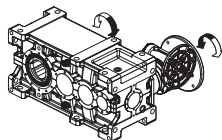

**C2 M1D**

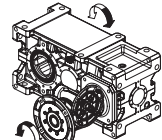

**C1S M1S**

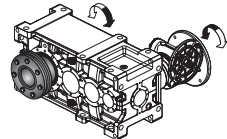

**C2S M1D**

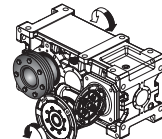

**C1D M1S**

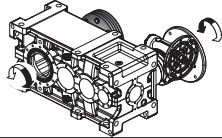

**C2D M1D**

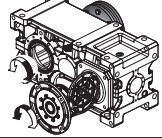

**RXP3-E**

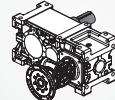

**800 Series**

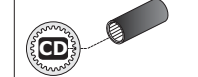
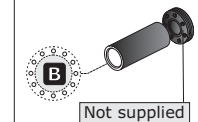
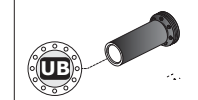
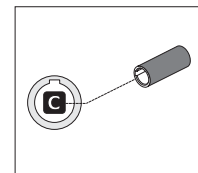
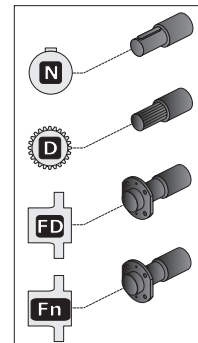

Not supplied

**1.7 Designazione**

**1.7 Designation**

**1.7 Bezeichnung**

**05 IR - Rapporto di riduzione**

**IR - Reduction ratio**

**IR - Übersetzungsverhältnis**

(Vedi prestazioni).  
Tutti i valori dei rapporti sono approssimati.  
Per applicazioni dove necessita il valore esatto consultare il ns. servizio tecnico.

(See ratings).  
Ratios are approximate values. If you need exact values for a specific application, please contact our Engineering.

(Siehe "Leistungen").  
Bei allen Werten der Übersetzungen handelt es sich um approximative Wertangaben. Bei Applikationen, bei denen die exakte Wertangabe erforderlich ist, muss unser Technischer Kundendienst konsultiert werden.

**06 DUSIZE - Grandezza differenziale**

**DUSIZE - Differential unit size**

**DUSIZE - Differentialgröße**

E70	E100	E125	E160	E180	E225
-----	------	------	------	------	------

**07 CM - Materiale carcassa**

**CM - Housing material**

**CM - Gehäusematerial**

		RXP 3											
Materiale carcassa / Housing material Gehäusematerial		802	804	806	808	810	812	814	816	818	820	822	824
Ghisa meccanica / Engineering cast iron Maschinenguss	<b>G</b>	"Standard"											
Ghisa sferoidale / Spheroidal cast iron Sphäroguss	<b>GS</b>	"On request"											
Acciaio / Steel / Stahl	<b>A</b>	"On request"											





1.7 Designazione









1.7 Designation

1.7 Bezeichnung

08 OS - Estremità uscita

OS - Output shaft

OS - Wellenende - Abtrieb

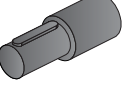
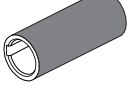
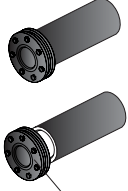
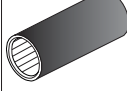
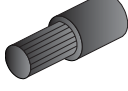
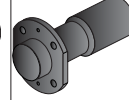
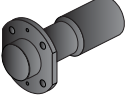



			 					
			 Not supplied					
	Standard <b>N</b>	Standard <b>C</b>	Standard <b>UB B</b>	Standard <b>CD</b>	Standard <b>D</b>	Standard <b>FD</b>	Standard <b>F...</b>	Standard <b>F1..</b>
<b>802</b>	(∅ 60xL112)	(∅ 60)	(∅ 60)	(60 x 55 DIN5482)	(FIAT 60)	(FIAT 60)	—	
<b>804</b>	(∅ 70xL125)	(∅ 70)	(∅ 70)	(70 x 64 DIN5482)	(FIAT 70)	(FIAT 70)	—	
<b>806</b>	(∅ 80xL140)	(∅ 80)	(∅ 80)	(80 x 74 DIN5482)	(FIAT 80)	(FIAT 80)	—	
<b>808</b>	(∅ 90xL160)	(∅ 90)	(∅ 90)	(90 x 84 DIN5482)	(FIAT 95)	(FIAT 95)	F1	F101
<b>810</b>	(∅ 100xL180)	(∅ 100)	(∅ 100)	(100 x 94 DIN5482)	(D. 105 DIN 5480)	(D. 105 DIN 5480)	F1 F2	F101 F102
<b>812</b>	(∅ 110xL200)	(∅ 110)	(∅ 110)	(110 x 3 x 35 DIN5480)	(D. 110 DIN 5480)	(D. 110 DIN 5480)	F2 F3	F102 F103
<b>814</b>	(∅ 125xL225)	(∅ 125)	(∅ 125)	(120 x 5 x 22 DIN5480)	(D. 130 DIN 5480)	(D. 130 DIN 5480)	F3 F4	F103 F104
<b>816</b>	(∅ 140xL250)	(∅ 140)	(∅ 140)	(140 x 5 x 26 DIN5480)	(D. 140 DIN 5480)	(D. 140 DIN 5480)	F4 F5	F104 F105
<b>818</b>	(∅ 160xL280)	(∅ 160)	(∅ 160)	(160 x 5 x 30 DIN5480)	(D. 160 DIN 5480)	(D. 160 DIN 5480)	F5 F6	F105 F106
<b>820</b>	(∅ 180xL315)	(∅ 180)	(∅ 180)	(180 x 8 x 21 DIN5480)	(D. 180 DIN 5480)	(D. 180 DIN 5480)	F6 F7	F106 F107
<b>822</b>	(∅ 200xL355)	(∅ 200)	(∅ 200)	—	(D. 200 DIN 5480)	(D. 200 DIN 5480)	F7 F8	F107 F108
<b>824</b>	(∅ 220xL400)	(∅ 220)	(∅ 220)	—	(D. 220 DIN 5480)	—	F8 F9	F108 F108

Per ulteriori informazioni vedere 1.12 / For more details, please read 1.12 / Sie können Weitere Informationen siehe 1.12

**FD**  
Non fornibili per classe di sollevamento M8

**FD**  
Not available for lifting class M8.

**FD**  
Für Hubklass M8 nicht lieferbar.

RXP 3	802	804	806	808	810	812	814	816	818	820	822	824
    	495 549	494 542	518 568	Ok! All	485 537	487 540	495 549	494 542	518 568	512 561	537	487 531

Nei rapporti contrassegnati non è disponibile la versione uscita con albero cavo - "C"- "UB"- "B"- "CD" / Hollow output shaft "C"- "UB"- "B"- "CD" not available for ratios / Bei den gekennzeichneten Übersetzungsverhältnissen ist die Version „Abtrieb mit Hohlwelle "C"- "UB"- "B"- "CD" Nicht verfügbar

<b>N</b>	Sporgente Integrale / Output shaft / Vollwelle
<b>C</b>	Albero Cavo / Hollow Shaft / Holwelle
<b>UB - B</b>	Albero cavo con unità di bloccaggio / Hollow output shaft with shrink disc / Hohlwelle mit Schrumpfscheibe
<b>CD</b>	Albero lento cavo scanalato / Splined hollow shaft / Verzahnte Hohlwelle
<b>D</b>	Estremità albero lento scanalato senza flangia brocciata / Splined output shaft without broached flange / Abtriebswelle mit Keilende ohne geräumtem Flansch
<b>FD</b>	Estremità scanalata albero lento flangia brocciata / Splined output shaft and broached flange / Abtriebswelle mit Keilende und geräumtem Flansch
<b>F1...F9</b>	Estremità scanalata albero lento con giunto <u>dentato</u> flangiato / Splined output shaft with flanged <u>splined</u> coupling / Abtriebswelle mit Keilende mit geflanschter Klauen kupplung
<b>F101...F108</b>	Estremità scanalata albero lento con giunto flangiato a <u>rulli</u> bombati / Splined output shaft with flanged <u>barrel rollers</u> coupling / Abtriebswelle mit Keilende mit geflanschter Tonnenrollen kupplung

**1.7 Designazione**

**1.7 Designation**

**1.7 Bezeichnung**

**09 MP - Posizioni di montaggio**

**MP - Mounting positions**

**MP - Einbaulagen**

Per ulteriori informazioni vedere 1.8 / For more details, please read 1.8 / Sie können Weitere Informationen siehe 1.8

**10 OPT-ACC. - Opzioni**

**OPT-ACC. - Options**

**OPT-ACC. - Optionen**

ACC1	Code	Per ulteriori informazioni vedere 1.12/For more details, please read 1.12/ Sie können Weitere Informationen siehe 1.12.			
	PROT.				
	<b>Code</b>				
<b>ACC7</b>	<b>AI</b>	Accessori idraulici	Hydraulic accessories	Hydraulisches Zubehör	
<b>ACC8</b>	<b>DT.</b>	Doppia tenuta...	Double seal...	Doppelte Dichtung...	
<b>OPT</b>	<b>VT.</b>	Paraoli in Viton...	Viton oil seals...	Ölabdichtungen aus Viton...	
	<b>SL.</b>	Paraoli in silicone...	Silicon oil seals...	Silikon-Dichtungsring...	
<b>ACC9</b>	<b>IS</b>	Coperchio d'ispezione	Inspection cover	Inspektionsdeckel	

Per ulteriori informazioni vedere SEZIONE U/For more details, please read SECTION U/Sie können Weitere Informationen siehe ABSCHNITT U

**KIT**

ACC1	Code	Per ulteriori informazioni vedere 1.12 / For more details, please read 1.12 / Sie können Weitere Informationen siehe 1.12		
	FF	RR	FF - Kit	FF - Kit
	<b>FF</b>	FF - Kit	FF - Kit	FF - Kit
	<b>RR</b>	Kit rosetta di montaggio	Mounting washer kit	Kit Montagescheibe

**11 EM - Macchina "Differenziale"**

**EM - Differenzial "Maschine"**

**EM - Differenzialgetriebe**



**E**

**12 SRIR - Rapporto fra la velocità massima e**

**SRIR - Maximum to minimum speed ratio.**

**SRIR - Verhältnis zwischen geforderter max. und min. Drehzahl**

$n_2/n_{211}$							Grandezza / Size / Größe
3.3	5	6.6	9.2	13.1	16.1	18.4	E70 - E100 E125 - E160
4	5	6	10	13	15	19	E180 - E225

**13 ESIZE - Grandezza differenziale**

**ESIZE - Differenzial size**

**ESIZE - Differenzialgröße**

E	70	100	125	160	180	225
---	----	-----	-----	-----	-----	-----

Nella tabella seguente sono riportati gli abbinamenti possibili tra differenziali e riduttori ad assi paralleli a 3 stadi di riduzione.

Listed in the table below are the possible combinations of differential units and triple-reduction in-line helical gear units.

In der nachstehenden Tabelle werden die zwischen Differential- und Parallelachsengetrieben mit 3 Übersetzungsstufen möglichen Passungen angegeben.

Grandezza riduttore accoppiato Coupled gear unit Gepassetes Getriebe	Differenziale Differential unit Differential					
	E70	E100	E125	E160	E180	E225
RXP3 802						
RXP3 804						
RXP3 806						
RXP3 808						
RXP3 810						
RXP3 812						
RXP3 814						
RXP3 816						
RXP3 818						
RXP3 820						
RXP3 822						
RXP3 824						

1.7 Designazione

1.7 Designation

1.7 Bezeichnung

<b>M</b> (Entrata Principale/ Main Input /Hauptantrieb)				<b>S</b> (Entrata Secondaria / Secondary Input / Nebenantrieb)			
<b>14</b> <b>IVM</b> Versione Entrata Input Version Antriebsausführung	<b>15</b> <b>ISM</b> Albero Entrata Input Shaft Antriebswelle	<b>16</b> <b>IECTM</b> Tipo IEC e Albero Entrata IEC type and Input Shaft IEC Typ und Antriebswelle		<b>17</b> <b>IVS</b> Versione Entrata Input Version Antriebsausführung	<b>18</b> <b>ISS</b> Albero Entrata Input Shaft Antriebswelle	<b>19</b> <b>IECTS</b> Tipo IEC e Albero Entrata IEC type and Input Shaft IEC Typ und Antriebswelle	
<b>ECE</b>	ECE	—	—	<b>ECE</b>	ECE	—	—
<b>PAM..D</b>	PAM	80 90 ...	D	<b>PAM..D</b>	PAM	80 90 ...	D

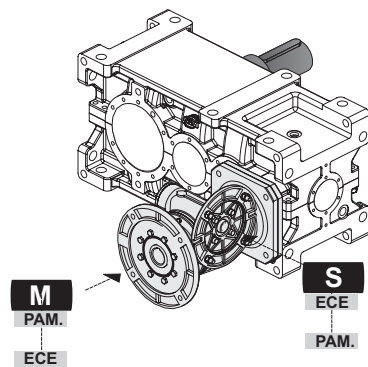

<p><b>ECE</b></p>	Entrata con albero pieno	Solid input shaft	Antrieb mit Vollwelle
<p><b>PAM...D</b></p>	IEC - Accoppiamento diretto	IEC - Direct coupling	IEC - direkte Passung

<b>E70</b> 	<b>ECE</b>		<b>PAM...D</b>																				
	U1	S1	IEC	$i_{M1}$								Grandezza riduttore accoppiato - RXP3 Coupled gear unit - RXP3 Gepasstes Getriebe - RXP3											
				3.3	5	6.6	9.2	13.1	16.1	18.4	802	804	806	808	810	812	814	816	818	820	822	824	
	19 j6	40	71																				
			80																				
			90																				

1.7 Designazione

1.7 Designation

1.7 Bezeichnung

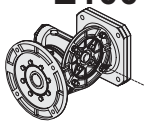

 <p><b>E100</b></p> <p>S ECE PAM.</p>	<b>ECE</b>		<b>PAM...D</b>																			
	U1	S1	IEC	$i_{1/n}$							Grandezza riduttore accoppiato - RXP3 Coupled gear unit - RXP3 Gepassetes Getriebe - RXP3											
	28 j6	60		3.3	5	6.6	9.2	13.1	16.1	18.4*	802	804	806	808	810	812	814	816	818	820	822	824
			90																			
			100																			
		112																				

\* Rapporto non standard / Ratio not standard / Übersetzung kein Standard

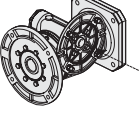
 <p><b>E125</b></p> <p>S ECE PAM.</p>	<b>ECE</b>		<b>PAM...D</b>																			
	U1	S1	IEC	$i_{1/n}$							Grandezza riduttore accoppiato - RXP3 Coupled gear unit - RXP3 Gepassetes Getriebe - RXP3											
	38 j6	80		3.3	5	6.6	9.2	13.1	16.1	18.4	802	804	806	808	810	812	814	816	818	820	822	824
			100																			
			112																			

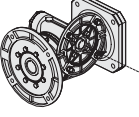
 <p><b>E160</b></p> <p>S ECE PAM.</p>	<b>ECE</b>		<b>PAM...D</b>																			
	U1	S1	IEC	$i_{1/n}$							Grandezza riduttore accoppiato - RXP3 Coupled gear unit - RXP3 Gepassetes Getriebe - RXP3											
	42 j6	100		3.3	5	6.6	9.2	13.1	16.1	18.4	802	804	806	808	810	812	814	816	818	820	822	824
			100																			
			112																			

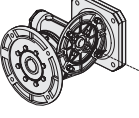
 <p><b>E180</b></p> <p>S ECE PAM.</p>	<b>ECE</b>		<b>PAM...D</b>																			
	U1	S1	IEC	$i_{1/n}$							Grandezza riduttore accoppiato - RXP3 Coupled gear unit - RXP3 Gepassetes Getriebe - RXP3											
	55 m6	100		4	5	6	10	13	15	19	802	804	806	808	810	812	814	816	818	820	822	824
			100																			
			112																			

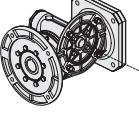
 <p><b>E225</b></p> <p>S ECE PAM.</p>	<b>ECE</b>		<b>PAM...D</b>																				
	U1	S1	IEC	$i_{1/n}$							Grandezza riduttore accoppiato - RXP3 Coupled gear unit - RXP3 Gepassetes Getriebe - RXP3												
	60 m6	112		4	5	6	10	13	15	19	802	804	806	808	810	812	814	816	818	820	822	824	
			132																				
			160																				

 <p><b>E70</b></p> <p>M PAM. ECE</p>	<b>ECE</b>		<b>PAM...D</b>																				
	U	S	IEC	Grandezza riduttore accoppiato - RXP3 Coupled gear unit - RXP3 Gepassetes Getriebe - RXP3																			
	28 j6	50		802	804	806	808	810	812	814	816	818	820	822	824								
			90																				
			100																				
			112																				
			132																				
			132																				
			160																				
			160																				
			180																				
			180																				

**1.7 Designazione**

**1.7 Designation**

**1.7 Bezeichnung**

**20** RSIZE - Grandezza riduttore accoppiato - RXP3

RSIZE - Coupled gear unit - RXP3

RSIZE - Gepassetes Getriebe - RXP3

RXP3 802	RXP3 804	RXP3 806	RXP3 808	RXP3 810	RXP3 812	RXP3 814	RXP3 816	RXP3 818	RXP3 820	RXP3 822	RXP3 824
-------------	-------------	-------------	-------------	-------------	-------------	-------------	-------------	-------------	-------------	-------------	-------------

**21** MV - Versione di Montaggio

MV - Mounting Version

MV - Montagausführung

M1D	M2D	M3D	M4D	M1S	M2S	M3S	M4S
-----	-----	-----	-----	-----	-----	-----	-----

Lubrificazione:  
Vedi paragrafo Lubrificazione.

Lubrication:  
See paragraph Lubrication.

Schmierung:  
Siehe Paragraph „Schmierung“

**22** PMTM - Posizione della Morsettiera - Principale

PMTM - Position Terminal Box - Main

PMTM - Haupt - Montagposition Klemmenkasten

[2, 3, 4] Posizione della morsettiera del motore se diversa da quella standard (1).

[2, 3, 4] Position of the motor terminal box if different from the standard one (1).

Montageposition Klemmenkasten [2, 3, 4], wenn abweichend von Standardposition [1] (für Motorgetriebe).

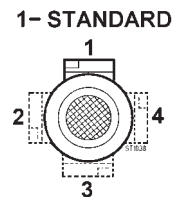
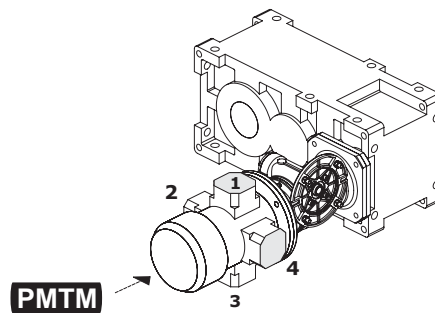

N.B.: Schema rappresentativo per Esecuzione Grafica B-BUS-BBU-C2-C2D-C2S:  
NOTE: Diagram applies to Shaft arrangement B-BUS-BBU-C2-C2D-C2S:  
HINWEIS: Schema für Grafische Ausführung B-BUS-BBU-C2-C2D-C2S gültig.

**23** PMTS - Posizione della Morsettiera - Secondaria

PMTS - Position Terminal Box - Secondary

PMTS - Neben - Montagposition Klemmenkasten

[2, 3, 4] Posizione della morsettiera del motore se diversa da quella standard (1).

[2, 3, 4] Position of the motor terminal box if different from the standard one (1).

Montageposition Klemmenkasten [2, 3, 4], wenn abweichend von Standardposition [1] (für Motorgetriebe).

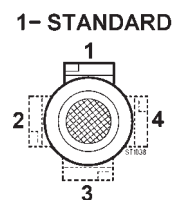
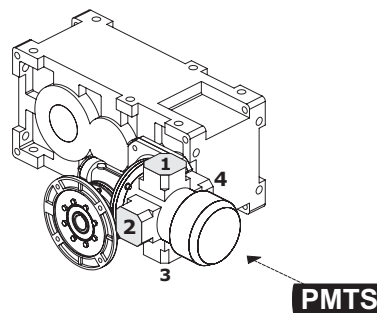



### 1.8 Lubrificazione

Gli oli disponibili appartengono generalmente a tre grandi famiglie:

- 1) Oli minerali
- 2) Oli sintetici Poli-Alfa-Olefine
- 3) Oli sintetici Poli-Glicole

La scelta più appropriata è generalmente legata alle condizioni di impiego. riduttori non particolarmente caricati e con un ciclo di impiego discontinuo, senza escursioni termiche importanti, possono certamente essere lubrificati con olio minerale.

Nei casi di impiego gravoso, quando i riduttori saranno prevedibilmente caricati molto ed in modo continuativo, con conseguente prevedibile innalzamento della temperatura, è bene utilizzare lubrificanti sintetici tipo polialfaolefine (PAO).

Gli oli di tipo poliglicole (PG) sono da utilizzare strettamente nel caso di applicazioni con forti strisciamenti fra i contatti, ad esempio nelle viti senza fine. Debbono essere impiegati con grande attenzione poiché non sono compatibili con gli altri oli e sono invece completamente miscibili con l'acqua. Questo fenomeno è particolarmente pericoloso poiché non si nota, ma deprime velocemente le caratteristiche lubrificanti dell'olio.

Oltre a questi già menzionati, ricordiamo che esistono gli oli per l'industria alimentare. Questi trovano specifico impiego nell'industria alimentare in quanto sono prodotti speciali non nocivi alla salute.

Vari produttori forniscono oli appartenenti a tutte le famiglie con caratteristiche molto simili. Più avanti proponiamo una tabella comparativa.

### 1.8 Lubrication

Available oils are typically grouped into three major classes:

- 1) Mineral oils
- 2) Poly-Alpha-Olefin synthetic oils
- 3) Polyglycol synthetic oils

*Oil is normally selected in accordance with environmental and operating conditions. Mineral oil is the appropriate choice for moderate load, non-continuous duty applications free from temperature extremes.*

*In severe applications, where gear units are to operate under heavy loads in continuous duty and high temperatures are expected, synthetic Poly-Alpha-Olefin oils (PAO) are the preferred choice.*

*Polyglycol oils (PG) should only be used in applications involving high sliding friction, as is the case with worm shafts. These particular oils should be used with great care, as they are not compatible with other oils, but are totally mixable with water. The oil mixed with water cannot be told from uncontaminated oil, but will degrade very rapidly.*

*In addition to the oils mentioned above, there are food-grade oils. These are special oils harmless to human health for use in the food industry.*

*Oils with similar characteristics are available from a number of manufacturers.*

*A comparative overview table is provided at the next pages.*

### 1.8 Schmierung

Die verfügbaren Öle gehören im Allgemeinen drei großen Familien an:

- 1) Mineralöle
- 2) Polyalphaolefine-Synthetiköle
- 3) Polyglykol-Synthetiköle

Die angemessene Wahl ist im Allgemeinen an die Einsatzbedingungen gebunden. Getriebe, die keinen besonders schweren Belastungen ausgesetzt sind und einem unregelmäßigen Einsatzzyklus unterliegen, ohne starke thermische Ausschläge, können problemlos mit Mineralöl geschmiert werden.

Bei einem Einsatz unter harten Bedingungen, d.h. wenn die Getriebe stark und andauernd belastet werden, woraus sich ein sicherer Temperaturanstieg ergibt, sollten Synthetiköle, Typ Polyalphaolefine (PAO), verwendet werden.

Die Öle, Typ Polyglykole (PG), sind ausschließlich für einen Einsatz ausgelegt, bei denen es zu starken Reibungen zwischen den in Kontakt stehenden Elementen kommt, z.B. bei Schnecken. Bei ihrem Einsatz in besondere Aufmerksamkeit erforderlich, da sie nicht mit anderen Ölen kompatibel sind, sich jedoch vollständig mit Wasser vermischen lassen. Diese Tatsache erweist sich daher als besonders gefährlich, da sie sich nicht feststellen lässt, jedoch die Schmiereigenschaften des Öls bereits nach kurzer Zeit unterdrückt.

Über die bereits genannten Öle hinaus, gibt es auch Öle, die speziell für die Lebensmittelindustrie ausgelegt sind. Diese finden demzufolge dort ihren Einsatz, da es sich dabei um spezielle Produkte handelt, die für die Gesundheit unschädlich sind.

Die den jeweiligen Familien angehörigen Ölsorten werden von verschiedenen Herstellern angeboten; sie weisen jeweils sehr ähnliche Eigenschaften auf.

Auf der folgenden Seite finden Sie eine entsprechende Vergleichstabelle.



Input speed $n_1$ (min <sup>-1</sup> )	Absorbed power (kW)	Viscosity ISO VG at 40° (cSt)	
		Differenziale Differential unit Differential	Riduttore Gear unit Getriebe
1000 < $n_1$ ≤ 2000	P < 7.5	220	220
	7.5 ≤ P ≤ 37		320
	P > 37		460

### 1.8 Lubrificazione

Nel caso di lubrificazione forzata con pompa, qualora siano richieste ISO VG > 220 e/o temperature < 10°C, consultarci.

La tabella è valida per velocità periferiche normali; in caso di velocità > 13m/s, consultarci.

Se la temperatura ambiente T < 0°C ridurre di una gradazione la viscosità prevista in tabella, viceversa aumentarla di una se T > 40°C.

Le temperature ammissibili per gli oli minerali sono: (-10 = T = 90)°C (fino a 100°C per periodi limitati).

Le temperature ammissibili per gli oli sintetici sono: (-20 = T = 110)°C (fino a 120°C per periodi limitati).

Per temperature dell'olio esterne a quelle ammissibili per il minerale e per aumentare l'intervallo di sostituzione del lubrificante adottare olio sintetico a base di polialfaolefine.

### 1.8 Lubrication

In case of forced lubrication by pump, when ISO VG > 220 and/or temperatures < 10°C, are requested, it is advisable to contact us.

The table is valid for normal peripheral speeds; in case of speed > 13 m/s, contact us.

If the environment temperature T < 0°C, decrease viscosity class by one, vice versa increase by one if T > 40°C.

Permissible temperatures for mineral oil are: (-10 = T = 90)°C, up to 100°C for a short time.

Permissible temperatures for synthetic oil are: (-20 = T = 110)°C, up to 120°C for a short time.

If the oil temperature is not permissible for mineral oil and for decreasing frequency of oil change, use synthetic oil with polyalphaolefins (PAOs).

### 1.8 Schmierung

Im Fall einer Zwangsschmierung über eine Pumpe, falls die ISO VG > 220 und/oder Temperaturen < 10°C gefordert werden, setzen Sie sich bitte mit uns in Verbindung.

Die Tabelle ist für normale Umfangsgeschwindigkeiten gültig. Bei Geschwindigkeiten > 13m/s, setzen Sie sich bitte mit uns in Verbindung.

Bei einer Umgebungstemperatur T < 0°C den von der Tabelle vorgesehene Viskositätsgrad um eine Gradation mindern und, im entgegengesetzten Fall, bei einer Temperatur T > 40°C, um eine anheben.

Für Mineralöle zulässige Temperaturen:

(-10 = T = 90)°C (bis 100°C über begrenzte Zeiträume).  
Für Synthetiköle zulässige Temperaturen:  
(-20 = T = 110)°C (bis 120°C über begrenzte Zeiträume).

Bei Temperaturen, die diese für Mineralöle zulässigen Werte überschreiten und um die Auswechselzeiten verlängern zu können, sollte Synthetiköl auf Basis von Polyalphaolefinen verwendet werden.

Manufacturer	Mineral oils(MINERAL)			Poly-Alpha-Olefin synthetic oils (PAO)			Polyglycol synthetic oils (PG)		
	ISO VG	ISO VG	ISO VG	ISO VG	ISO VG	ISO VG	ISO VG	ISO VG	ISO VG
	150	220	320	150	220	320	150	220	320
AGIP	Blasia 150	Blasia 220	Blasia 320	-	Blasia SX 220	Blasia SX 320	Blasia S 150	Blasia S 220	Blasia S 320
ARAL	Degol BG 150 Plus	Degol BG 220 Plus	Degol BG 320 Plus	Degol PAS 150	Degol PAS 220	Degol PAS 320	Degol GS 150	Degol GS 220	Degol GS 320
BP	Energol GR-XP 150	Energol GR-XP 220	Energol GR-XP 320	Energol EPX 150	Energol EPX 220	Energol EPX 320	Energol SG 150	Energol SG-XP 220	Energol SG-XP 320
CASTROL	Alpha SP 150	Alpha SP 220	Alpha SP 320	Alphasyn EP 150	Alphasyn EP 220	Alphasyn EP 320	Alphasyn PG 150	Alphasyn PG 220	Alphasyn PG 320
CHEVRON	Ultra Gear 150	Ultra Gear 220	Ultra Gear 320	Tegra Synthetic Gear 150	Tegra Synthetic Gear 220	Tegra Synthetic Gear 320	HiPerSYN 150	HiPerSYN 220	HiPerSYN 320
ESSO	Spartan EP 150	Spartan EP 220	Spartan EP 320	Spartan S EP 150	Spartan S EP 220	Spartan S EP 320	Glycolube 150	Glycolube 220	Glycolube 320
KLÜBER	Klüberoil GEM 1-150	Klüberoil GEM 1-220	Klüberoil GEM 1-320	Klübersynth EG 4-150	Klübersynth EG 4-220	Klübersynth EG 4-320	Klübersynth GH 6-150	Klübersynth GH 6-220	Klübersynth GH 6-320
MOBIL	Mobilgear XMP 150	Mobilgear XMP 220	Mobilgear XMP 320	Mobilgear SHC XMP 150	Mobilgear SHC XMP 220	Mobilgear SHC XMP 320	Glygoyle 22	Glygoyle 30	Glygoyle HE320
MOLIKOTE	L-0115	L-0122	L-0132	L-1115	L-1122	L-1132	-	-	-
OPTIMOL	Optigear BM 150	Optigear BM 220	Optigear BM 320	Optigear Synthetic A 150	Optigear Synthetic A 220	Optigear Synthetic A 320	Optiflex A 150	Optiflex A 220	Optiflex A 320
PAKELO	EROLUBE EP C ISO 150	EROLUBE EP C ISO 220	EROLUBE EP C ISO 320	GEARSINT EPN ISO 150	GEARSINT EPN ISO 220	GEARSINT EPN ISO 320	ALLSINT HS ISO 150	ALLSINT HS ISO 220	ALLSINT HS ISO 320
PETRONAS	PETRONAS GEAR MEP 150	PETRONAS GEAR MEP 220	PETRONAS GEAR MEP 320	PETRONAS GEAR SYN PAO 150	PETRONAS GEAR SYN PAO 220	PETRONAS GEAR SYN PAO 320	PETRONAS GEAR SYN PAG 150	PETRONAS GEAR SYN PAG 220	PETRONAS GEAR SYN PAG 320
Q8	Goya 150	Goya 220	Goya 320	El Greco 150	El Greco 220	El Greco 320	Gade 150	Gade 220	Gade 320
SHELL	OMALA S2 GX 150	OMALA S2 GX 220	OMALA S2 GX 320	Omala S4 GXV 150	Omala S4 GXV 220	Omala S4 GXV 320	OMALA S4 WE 150	OMALA S4 WE 220	OMALA S4 WE 320
TEXACO	Meropa 150	Meropa 220	Meropa 320	Pinnacle EP 150	Pinnacle EP 220	Pinnacle EP 320	-	Synlube CLP 220	Synlube CLP 320
TOTAL	Carter EP 150	Carter EP 220	Carter EP 320	Carter SH 150	Carter SH 220	Carter SH 320	Carter SY 150	Carter SY 220	Carter SY 320
TRIBOL	1100/150	1100/220	1100/320	1510/150	1510/220	1510/320	800/150	800/220	800/320

#### Food-grade synthetic lubricants

AGIP				Rocol Foodlube Hi-Torque 150	—	Rocol Foodlube Hi-Torque 320			
ESSO				—	Gear Oil FM 220	—			
FUCHS				Cassida Fluid GL 150	Cassida Fluid GL 220	Cassida Fluid GL 320			
KLÜBER				Klüberoil 4 UH1 N 150	Klüberoil 4 UH1 N 220	Klüberoil 4 UH1 N 320			
MOBIL				Mobil SHC Cibus Series 150	Mobil SHC Cibus Series 220	Mobil SHC Cibus Series 320			
PAKELO				NON TOX OIL GEAR EP ISO 150	NON TOX OIL GEAR EP ISO 220	NON TOX OIL GEAR EP ISO 320			

1.8 Lubrificazione

1.8 Lubrication

1.8 Schmierung

Lubrificazione differenziale

Differential unit lubrication

Schmierung des Differentials

Generalità

Si consiglia l'uso di oli a base sintetica PAO.

Nella tab. 2.2 sono riportati i quantitativi di olio necessari per il corretto funzionamento dei riduttori.

Prescrizioni in fase di ordine e stato di fornitura

I riduttori delle grandezze 70 sono forniti completi di olio sintetico di viscosità ISO 320.

I riduttori delle grandezze 100, 125, 160, 180, 225 sono forniti predisposti per lubrificazione ad olio ma privi di lubrificante il quale potrà essere fornito a richiesta. È sempre necessario specificare la posizione di montaggio.

General information

The use of synthetic oil PAO is recommended.

The correct oil quantities for proper gear unit operation are reported in tab. 2.2.

Information required on order - Delivery condition

Size 70 gear units are factory filled with ISO 320 synthetic oil.

Sizes 100, 125, 160, 180 and 225 are oil lubricated, but are supplied dry. Lubricant is available on request. Always specify the desired mounting position.

Allgemeines

Es wird der Einsatz von synthetischem Öl PAO empfohlen. In der Tabelle Tab. 2.2 werden die für einen störungsfreien Betrieb der Getriebe erforderlichen Ölfüllmengen angegeben.

Vorgaben für Bestellung und Lieferzustand

Die Getriebe in den Baugrößen 70 werden komplett mit Synthetiköl mit einer Viskosität ISO 320 geliefert.

Die Getriebe in den Baugrößen 100, 125, 160, 180 und 225 sind bei der Lieferung für die Ölschmierung vorbereitet, enthalten jedoch kein Schmiermittel. Dieses kann jedoch auf Anfrage geliefert werden. Bei diesen Getrieben muss immer die Einbaulage angegeben werden.

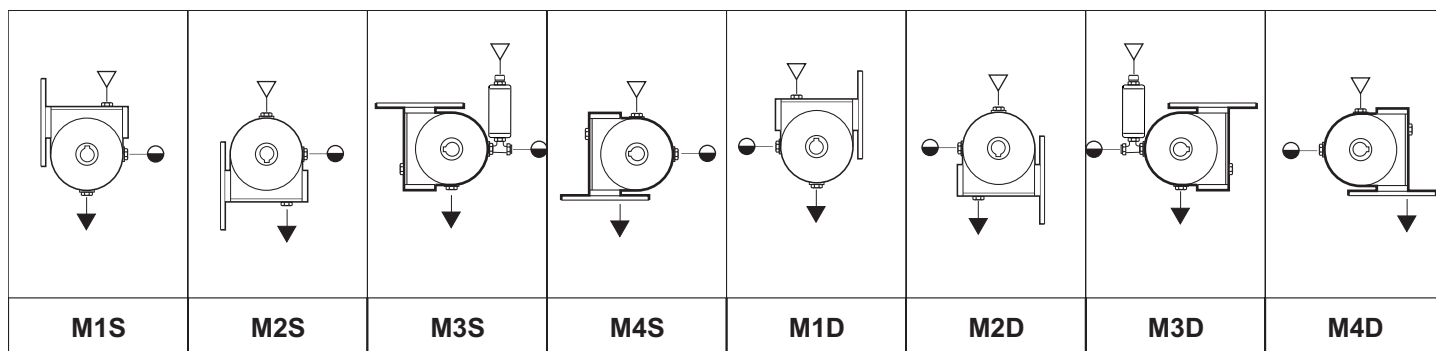

Quantità di lubrificante / Lubricant Quantity / Schmiermittelmenge (l)							
E	Posizioni di montaggio Mounting Positions Einbaulage (S,I,D,F)						Stato di fornitura Delivery condition Lieferzustand
	M1	M2	M3	M4	M5	M6	
70	0.700						Riduttori forniti completi di lubrificante sintetico Factory filled with synthetic oil Getriebe werden mit Synthetiköl geliefert
100	4.0		2.1 <sup>(1)</sup>				
125	5.5		2.9 <sup>(1)</sup>				
160	9.0		5.0 <sup>(1)</sup>				
180	17.0		7.8 <sup>(1)</sup>				
225	25.0		11.5 <sup>(1)</sup>			Riduttori predisposti per lubrificazione ad olio Oil lubricated, supplied dry Getriebe sind für Ölschmierung ausgelegt	

(1) Quantità indicative; durante il riempimento attenersi alla spia di livello.

(1) Indicative quantities, check the oil sight glass during filling.

(1) Ungefähre Mengen; beim Füllen auf das Schauglas Bezug nehmen.

A) In tutte le grandezze di differenziale è necessario in fase d'ordine indicare la posizione di montaggio sia se i riduttori sono richiesti con olio sia privi di lubrificante. Particolare attenzione va posta per i riduttori da gr. 100 a gr. 125 montati nelle posizioni M3 e M4 che sono forniti con il cuscinetto schermato.

A) For differential units, mounting position must always be specified for all sizes, regardless of gear unit delivery condition (factory filled or dry). Particular attention is required for gear unit sizes 100 to 125 designated for mounting positions M3 and M4, as they use a shielded bearing.

A) Für alle Baugrößen der Differentialgetriebe muss in der Auftragsphase die Einbaulage angegeben werden. Dies gilt sowohl für Bestellung von mit Öl gefüllten Getrieben als auch für Getriebe ohne Schmiermittel. Besondere Aufmerksamkeit sollte den Getrieben der Größen 100 bis 125 zukommen, die in den Einbaulagen M3 und M4 montiert werden und mit abgeschirmtem Lager geliefert werden.

B) Per i differenziali delle grandezze 100, 125, 160, 180, 225 nelle posizioni M1 non fare riferimento alla spia di livello ma attenersi ai quantitativi indicati. (La quantità d'olio necessaria supera il livello del differenziale).

B) For size 100, 125, 160, 180, 225 differential units in mounting position M1, disregard the sight glass and fill with the specified quantity of oil. (Correct oil level exceeds level mark on differential unit sight glass).

B) Bei den Differentialgetrieben der Baugrößen 100, 125, 160, 180, 225 in den Einbaulagen M1 ist nicht auf das Schauglas, sondern auf die angegebenen Mengen Bezug zu nehmen. (Die erforderliche Ölmenge übersteigt den Füllstand des Differentialgetriebes).

C) Il tappo di sfiato è allegato solo nei riduttori che hanno più di un tappo olio.

C) A breather plug is only supplied when gear unit has more than one oil plugs.

C) Die Entlüftungsschraube ist lediglich bei den Getrieben vorhanden, die über mehr als einen Ölfüllstopfen verfügen.

1.8 Lubrificazione

1.8 Lubrication

1.8 Schmierung

Lubrificazione RXP3

RXP3 lubrication

Schmierung RXP3

Posizioni di montaggio

Mounting positions

Einbaulagen

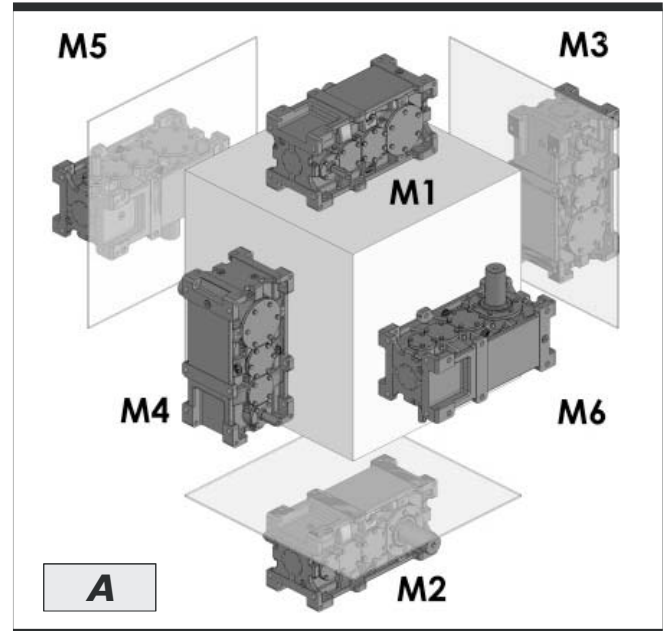
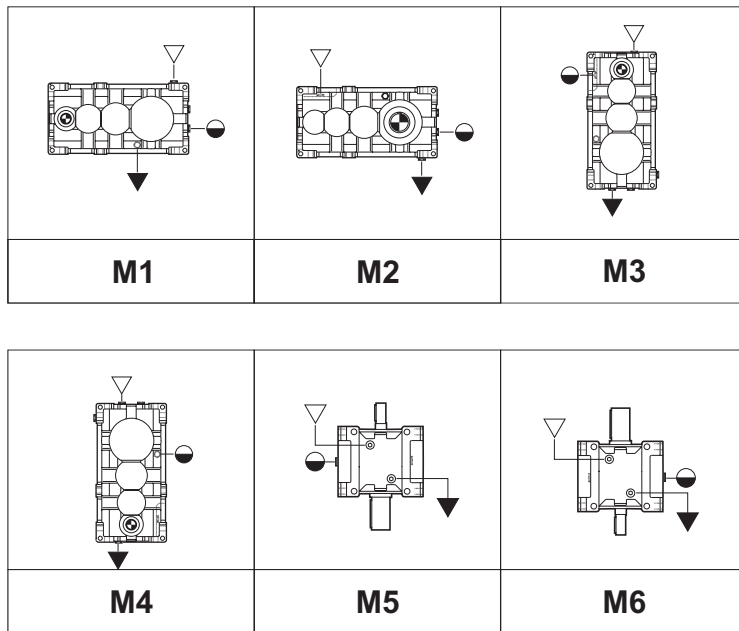

- ▽ Carico / Filler plug / Einfüllschraube
- ▼ Scarico / Drain plug / Ablassschraube
- Livello / Level plug / Schauglas

L'esecuzione grafica rappresentata è la A.  
The noted version is A.  
Die dargestellte Version ist A.

		Quantità di lubrificante / Lubricant Quantity / Schmiermittelmenge (l)											
		802	804	806	808	810	812	814	816	818	820	822	824
RXP3	M1 - M2	3.9	5.5	7.6	11	15	21	29	41	58	81	113	158
	M3	8.1	11	15	22	32	44	62	87	125	175	246	345
	M4	6.6	9.2	13	18	26	36	50	71	102	144	201	285
	M5 - M6	5.1	7.3	10	14	20	28	40	56	79	111	156	218

Le quantità di olio sono approssimative; per una corretta lubrificazione occorre fare riferimento al livello segnato sul riduttore.

*Oil quantities listed in the table are approximate; to ensure correct lubrication, please refer to the level mark on the gear unit.*

Bei den Ölmenangaben handelt es sich um approximative Werte; für den Erhalt einer korrekten Schmierung muss Bezug auf den am Getriebe gekennzeichneten Füllstand genommen werden.

**ATTENZIONE**

Eventuali forniture con predisposizioni tappi diverse da quella indicata in tabella, dovranno essere concordate.

**WARNING**

*Any plug arrangements other than that indicated in the table must be agreed upon.*

**ACHTUNG**

Eventuelle Lieferungen mit einer von den Tabellenangaben abweichenden Anordnung der Stopfen, müssen zuvor abgestimmt werden.

**Lubrificazione cuscinetti superiori RXP3 E**

**RXP3 E upper bearing lubrication**

**Schmierung der oberen Lager Lager RXP3 E**

In caso di montaggio in posizione M5 ed M6 per le grandezze da 802 a 820 la lubrificazione dei cuscinetti superiori del riduttore ad assi paralleli viene assicurata tramite grasso lunga vita ed anelli nilos. Per le grandezze superiori consultare il ns. servizio tecnico commerciale.

*In-line helical gear unit sizes 802 through 820 designated for mounting positions M5 and M6 have upper bearings charged with long-life grease and Nilos rings. For larger sizes, please contact our Sales Engineers.*

Bei einer Einbaulage in der Position M5 und M6 wird die Schmierung der oberen Lager des Parallelachsengetriebe bei den Baugrößen 802 bis 820 durch den Einsatz eines "long life"-Fetts mit Nilos-Ringen gesichert. Für darüber liegende Baugrößen ist Beratung bei unseren Technischen Kundendienst einzuholen.



1.8 Lubrificazione

1.8 Lubrication

1.8 Schmierung

Lubrificazione RXP3

RXP3 lubrication

Schmierung RXP3

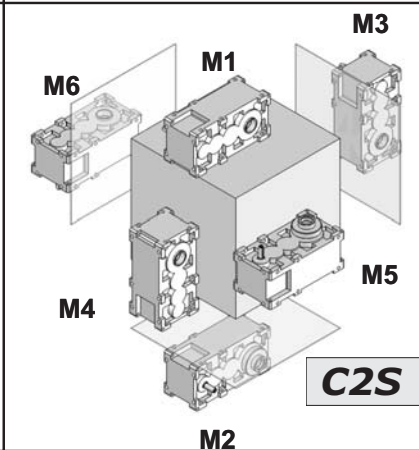
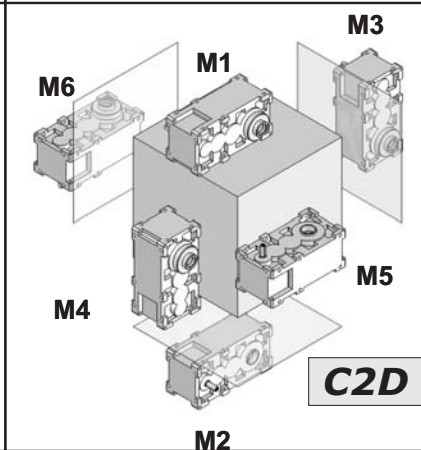
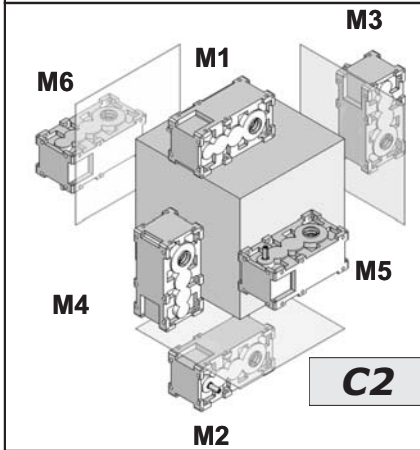
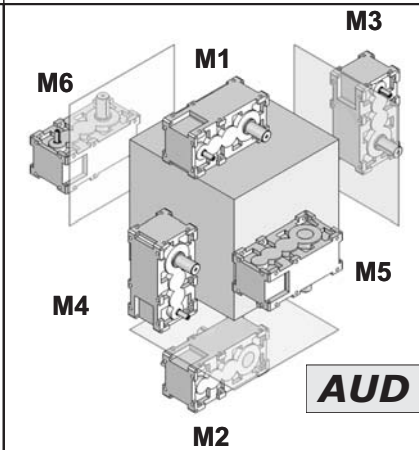
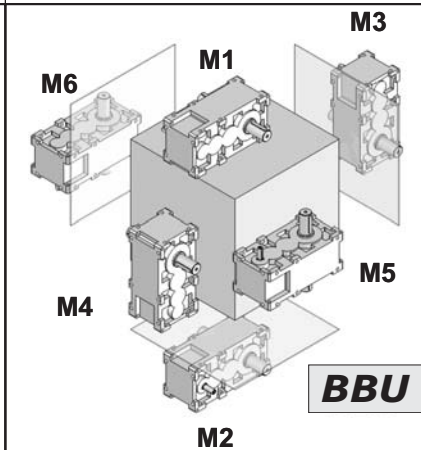
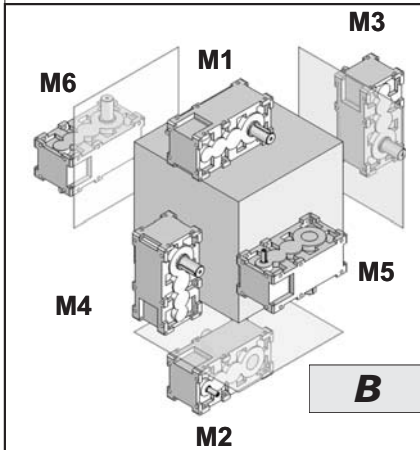
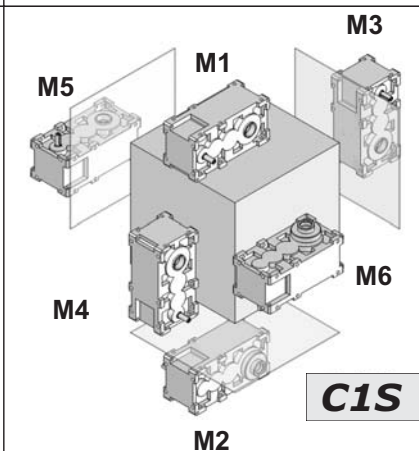
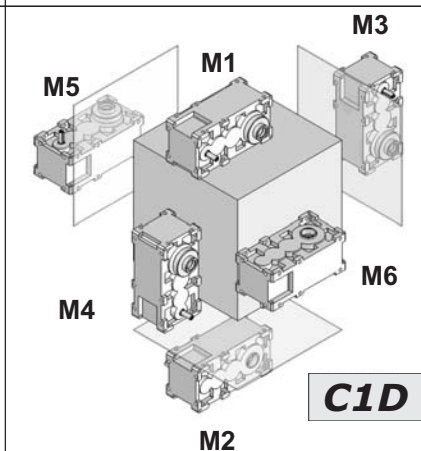
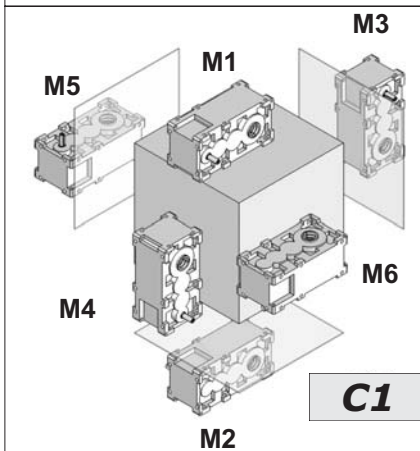
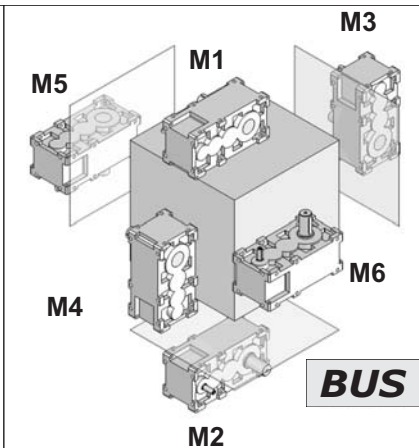
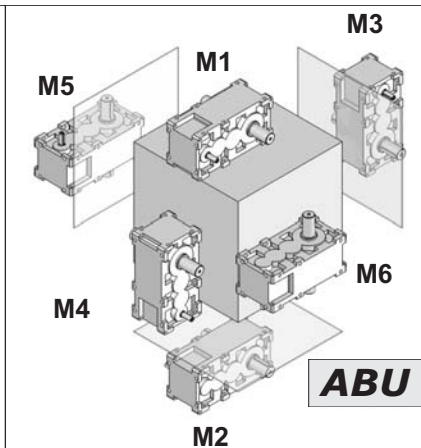
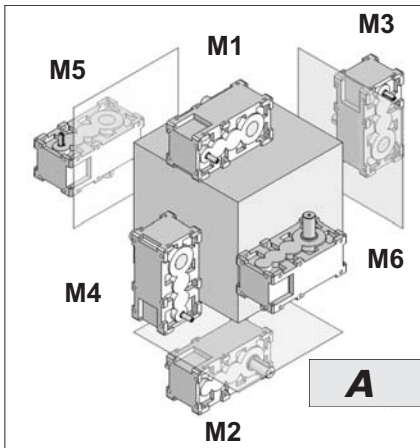



1.9 RXP3 applicato al differenziale

1.9 RXP3 coupled with differential unit

1.9 Am Differential appliziertes RXP3-Getriebe

n <sub>1</sub> min <sup>-1</sup>	99 802					138 804					243 806					273 808				
	ir	n <sub>2</sub> min <sup>-1</sup>	P <sub>N</sub> kW	T <sub>N</sub> kNm	Fr <sub>2</sub> kN	ir	n <sub>2</sub> min <sup>-1</sup>	P <sub>N</sub> kW	T <sub>N</sub> kNm	Fr <sub>2</sub> kN	ir	n <sub>2</sub> min <sup>-1</sup>	P <sub>N</sub> kW	T <sub>N</sub> kNm	Fr <sub>2</sub> kN	ir	n <sub>2</sub> min <sup>-1</sup>	P <sub>N</sub> kW	T <sub>N</sub> kNm	Fr <sub>2</sub> kN
1450	31.7	45.8	14.0	2.7	12	33.5	43.3	19.7	4.0	16	33.5	43.2	27	5.6	21	29.4	49.3	37	6.6	38
	35.6	40.7	14.0	3.0	12	37.6	38.6	19.7	4.5	16	39.8	36.5	27	6.6	21	34.8	41.6	37	7.8	38
	40.2	36.0	13.8	3.4	12	42.4	34.2	18.7	4.8	16	42.2	34.4	27	7.0	21	39.2	37.0	37	8.8	38
	45.7	31.7	12.2	3.4	12	48.2	30.1	16.5	4.8	16	47.7	30.4	25	7.3	21	44.2	32.8	37	9.9	38
	52.4	27.7	10.7	3.4	12	51.5	28.2	15.5	4.8	16	54.3	26.7	22	7.3	21	47.1	30.8	36	10.4	38
	56.3	25.8	10.0	3.4	12	59.2	24.5	13.6	4.9	16	58.1	24.9	21	7.4	21	57.6	25.2	30	10.5	38
	60.6	23.9	9.3	3.4	11.5	63.8	22.7	12.7	4.9	15.5	67.1	21.6	18.2	7.4	20	66.6	21.8	26	10.6	36
	71.0	20.4	8.0	3.5	11.5	74.7	19.4	10.9	4.9	15.5	72.5	20.0	16.9	7.4	20	78.1	18.6	23	10.7	36
	77.3	18.8	7.5	3.5	11.5	81.3	17.8	10.1	5.0	15.5	85.5	17.0	14.5	7.5	20	85.0	17.1	21	10.7	36
	84.6	17.1	6.8	3.5	11.5	89.0	16.3	9.3	5.0	15.5	93.5	15.5	13.2	7.5	20	93.0	15.6	19.2	10.8	36
	101	14.3	5.7	3.5	11	102	14.2	8.1	5.0	15	102	14.2	12.3	7.6	19	105	13.8	17.0	10.8	34
	115	12.6	5.0	3.5	11	115	12.6	7.2	5.0	15	108	13.4	11.6	7.6	19	112	13.0	15.9	10.8	34
	132	11.0	4.4	3.5	11	123	11.8	6.7	5.0	15	122	11.9	10.3	7.6	19	128	11.4	14.0	10.8	34
	142	10.2	4.1	3.5	11	142	10.2	5.8	5.0	15	139	10.4	9.0	7.6	19	137	10.6	13.0	10.8	34
	153	9.5	3.8	3.5	11	152	9.5	5.4	5.0	15	172	8.4	7.3	7.6	19	158	9.2	11.3	10.8	34
	179	8.1	3.2	3.5	11	178	8.1	4.6	5.0	15	186	7.8	6.8	7.6	19	185	7.8	9.6	10.8	34
	195	7.4	3.0	3.5	11	194	7.5	4.3	5.0	15	219	6.6	5.7	7.6	19	202	7.2	8.8	10.8	34
	213	6.8	2.7	3.5	11	213	6.8	3.9	5.0	15	239	6.1	5.2	7.6	19	221	6.6	8.1	10.8	34
	243	6.0	2.4	3.5	11	270	5.4	3.1	5.0	15	240	6.0	5.2	7.6	19	236	6.1	7.5	10.8	34
	299	4.8	1.9	3.5	11	290	5.0	2.8	5.0	15	278	5.2	4.5	7.6	19	273	5.3	6.5	10.8	34
322	4.5	1.8	3.5	11	340	4.3	2.4	5.0	15	300	4.8	4.2	7.6	19	320	4.5	5.6	10.8	34	
378	3.8	1.5	3.5	11	370	3.9	2.2	5.0	15	354	4.1	3.5	7.6	19	349	4.2	5.1	10.8	34	
411	3.5	1.4	3.5	11	405	3.6	2.0	5.0	15	387	3.8	3.2	7.6	19	420	3.5	4.2	10.8	34	
450	3.2	1.3	3.5	11	444	3.3	1.7	4.5	15	425	3.4	2.9	7.6	19	465	3.1	3.8	10.8	34	
495*	2.9	1.2	3.5	11	494*	2.9	1.7	5.0	15	518*	2.8	2.4	7.6	19	512	2.8	3.5	10.8	34	
549*	2.6	1.1	3.5	11	542*	2.7	1.4	4.5	15	568*	2.6	1.9	6.7	19	561	2.6	2.9	9.8	34	

n <sub>1</sub> min <sup>-1</sup>	382 810					534 812					758 814					1045 816				
	ir	n <sub>2</sub> min <sup>-1</sup>	P <sub>N</sub> kW	T <sub>N</sub> kNm	Fr <sub>2</sub> kN	ir	n <sub>2</sub> min <sup>-1</sup>	P <sub>N</sub> kW	T <sub>N</sub> kNm	Fr <sub>2</sub> kN	ir	n <sub>2</sub> min <sup>-1</sup>	P <sub>N</sub> kW	T <sub>N</sub> kNm	Fr <sub>2</sub> kN	ir	n <sub>2</sub> min <sup>-1</sup>	P <sub>N</sub> kW	T <sub>N</sub> kNm	Fr <sub>2</sub> kN
1450	31.7	45.8	52	10.0	48	31.2	46.5	77	14.5	53	31.7	45.8	112	21.5	63	33.5	43.3	155	31.5	75
	37.7	38.4	52	11.9	48	35.1	41.4	77	16.3	53	35.6	40.7	112	24.2	63	37.6	38.6	155	35.4	75
	42.6	34.0	52	13.5	48	39.6	36.6	77	18.4	53	40.2	36.0	112	27.4	63	42.4	34.2	155	39.9	75
	45.4	32.0	52	14.2	48	45.0	32.2	77	20.9	53	45.7	31.7	104	28.8	63	48.2	30.1	142	41.3	75
	51.8	28.0	46	14.3	48	51.6	28.1	68	21.2	53	52.4	27.7	91	29.0	63	51.5	28.2	133	41.5	75
	55.5	26.1	43	14.4	48	55.4	26.2	63	21.3	53	56.3	25.8	85	29.1	63	59.2	24.5	116	41.8	75
	64.2	22.6	37	14.5	46	64.4	22.5	55	21.5	51	60.6	23.9	79	29.2	60	63.8	22.7	108	41.9	72
	75.2	19.3	32	14.6	46	69.9	20.7	51	21.5	51	71.0	20.4	68	29.4	60	74.7	19.4	93	42.2	72
	81.9	17.7	29	14.6	46	83.3	17.4	43	21.7	51	77.3	18.8	63	29.5	60	81.3	17.8	86	42.4	72
	89.6	16.2	27	14.7	46	88.3	16.4	41	21.8	51	84.6	17.1	58	29.7	60	89.0	16.3	79	42.6	72
	98.0	14.8	25	14.8	44	99.8	14.5	36	21.9	49	101	14.3	49	29.9	58	96.3	15.1	73	42.8	70
	118	12.3	21	14.8	44	113	12.8	32	21.9	49	115	12.6	43	29.9	58	109	13.3	65	42.8	70
	135	10.8	18.2	14.8	44	130	11.2	28	21.9	49	132	11.0	37	29.9	58	123	11.7	57	42.8	70
	144	10.1	16.9	14.8	44	140	10.4	26	21.9	49	142	10.2	35	29.9	58	152	9.6	47	42.8	70
	167	8.7	14.6	14.8	44	162	8.9	22	21.9	49	153	9.5	32	29.9	58	163	8.9	43	42.8	70
	195	7.4	12.5	14.8	44	176	8.2	21	21.9	49	179	8.1	28	29.9	58	191	7.6	37	42.8	70
	213	6.8	11.5	14.8	44	192	7.6	18.8	21.9	49	195	7.4	25	29.9	58	208	7.0	34	42.8	70
	233	6.2	10.5	14.8	44	210	6.9	17.2	21.9	49	213	6.8	23	29.9	58	228	6.4	31	42.8	70
	255	5.7	9.6	14.8	44	239	6.1	15.1	21.9	49	243	6.0	20	29.9	58	270	5.4	26	42.8	70
	273	5.3	9.0	14.8	44	294	4.9	12.3	21.9	49	299	4.8	16.5	29.9	58	290	5.0	24	42.8	70
316	4.6	7.7	14.8	44	343	4.2	10.5	21.9	49	322	4.5	15.3	29.9	58	340	4.3	21	42.8	70	
370	3.9	6.6	14.8	44	372	3.9	9.7	21.9	49	378	3.8	13.1	29.9	58	370	3.9	19.1	42.8	70	
403	3.6	6.1	14.8	44	405	3.6	8.9	21.9	49	411	3.5	12.0	29.9	58	405	3.6	17.4	42.8	70	
441	3.3	5.5	14.8	44	443	3.3	8.2	21.9	49	450	3.2	11.0	29.9	58	444	3.3	14.3	38.5	70	
485*	3.0	5.0	14.8	44	487*	3.0	7.4	21.9	49	495*	2.9	10.0	29.9	58	494*	2.9	14.3	42.8	70	
537*	2.7	4.5	14.8	44	540*	2.7	6.7	21.9	49	549*	2.6	9.0	29.9	58	542*	2.7	11.9	38.5	70	

\* Nei rapporti contrassegnati non è disponibile la versione uscita con albero cavo "C"-UB"-B"-CD".

\* Hollow output shaft "C"-UB"-B"-CD" not available for ratios marked with this symbol.

\* Bei den gekennzeichneten Übersetzungsverhältnissen ist die Version "Abtrieb mit Hohlwelle" "C"-UB"-B"-CD" nicht verfügbar.

## 1.9 RXP3 applicato al differenziale

## 1.9 RXP3 coupled with differential unit

## 1.9 Am Differential appliziertes RXP3-Getriebe



$n_1$ min <sup>-1</sup>	1464 <b>818</b>					G-2049 A-2106 <b>820</b>					3000 <b>822</b>					G-4100 A-4000 <b>824</b>				
	ir	$n_2$ min <sup>-1</sup>	$P_N$ kW	$T_N$ kNm	$Fr_2$ kN	ir	$n_2$ min <sup>-1</sup>	$P_N$ kW	$T_N$ kNm	$Fr_2$ kN	ir	$n_2$ min <sup>-1</sup>	$P_N$ kW	$T_N$ kNm	$Fr_2$ kN	ir	$n_2$ min <sup>-1</sup>	$P_N$ kW	$T_N$ kNm	$Fr_2$ kN
1450	33.5	43.2	213	43.3	108	29.4	49.3	298	53.1	150	33.6	45.8	418	80.3	188	31.2	46.5	613	116	210
	37.5	38.6	213	48.5	108	34.8	41.6	297	62.8	150	37.7	38.4	418	95.5	188	35.1	41.4	613	130	210
	42.2	34.4	213	54.5	108	39.2	37.0	297	70.6	150	42.6	34.0	418	108	188	39.6	36.6	613	147	210
	47.7	30.4	211	60.9	108	44.2	32.8	297	79.8	150	48.4	29.9	390	114	188	45.0	32.2	613	167	210
	54.3	26.7	186	61.3	108	47.1	30.8	293	83.6	150	51.8	28.0	366	115	188	51.6	28.1	549	171	210
	58.1	24.9	175	61.5	108	53.8	27.0	258	84.1	150	55.5	26.1	343	115	188	55.4	26.2	513	172	210
	67.1	21.6	152	62.0	103	61.9	23.4	226	84.7	145	64.2	22.6	298	116	182	64.4	22.5	444	173	205
	72.5	20.0	142	62.2	103	72.0	20.1	196	85.4	145	75.2	19.3	257	117	182	69.9	20.7	411	174	205
	85.5	17.0	121	62.7	103	78.1	18.6	181	85.7	145	81.9	17.7	236	117	182	83.3	17.4	349	176	205
	93.5	15.5	111	63.0	103	93.0	15.6	153	86.5	145	89.6	16.2	217	118	182	91.7	15.8	317	176	205
	96.1	15.1	108	63.1	103	105	13.8	136	86.8	142	98.0	14.8	199	118	178	99.8	14.5	293	177	200
	108	13.4	97	63.2	100	112	13.0	128	86.8	142	111	13.1	177	119	178	113	12.8	258	177	200
	122	11.9	85	63.2	100	128	11.4	112	86.8	142	126	11.5	156	119	178	130	11.2	225	177	200
	139	10.4	75	63.2	100	147	9.9	97	86.8	142	144	10.1	136	119	178	140	10.4	209	177	200
	172	8.4	61	63.2	100	171	8.5	84	86.8	142	167	8.7	118	119	178	162	8.9	180	177	200
	186	7.8	56	63.2	100	185	7.8	77	86.8	142	195	7.4	101	119	178	176	8.2	166	177	200
	219	6.6	48	63.2	100	202	7.2	71	86.8	142	213	6.8	92	119	178	210	6.9	139	177	200
	239	6.1	44	63.2	100	221	6.6	65	86.8	142	233	6.2	84	119	178	231	6.3	126	177	200
	247	5.9	42	63.2	100	243	6.0	59	86.8	142	255	5.7	77	119	178	247	5.9	118	177	200
	265	5.5	39	63.2	100	279	5.2	51	86.8	142	273	5.3	72	119	178	266	5.5	110	177	200
306	4.7	34	63.2	100	325	4.5	44	86.8	142	316	4.6	62	119	178	309	4.7	94	177	200	
330	4.4	32	63.2	100	352	4.1	41	86.8	142	370	3.9	53	119	178	335	4.3	87	177	200	
389	3.7	27	63.2	100	384	3.8	37	86.8	142	403	3.6	49	119	178	400	3.6	73	177	200	
425	3.4	25	63.2	100	420	3.5	34	86.8	142	441	3.3	45	119	178	440	3.3	66	177	200	
518*	2.8	20	63.2	100	512*	2.8	28	86.8	142	485	3.0	40	119	178	487*	3.0	60	177	200	
568*	2.6	16.4	56.5	100	561*	2.6	24	80.0	142	537*	2.7	37	119	178	531*	2.7	50	160	200	

\* Nei rapporti contrassegnati non è disponibile la versione uscita con albero cavo "C"- "UB"- "B"- "CD".

\* Hollow output shaft "C"- "UB"- "B"- "CD" not available for ratios marked with this symbol.

\* Bei den gekennzeichneten Übersetzungsverhältnissen ist die Version "Abtrieb mit Hohlwelle" "C"- "UB"- "B"- "CD" nicht verfügbar.

## 1.9 Prestazioni differenziale

## 1.9 Differential unit ratings

## 1.9 Leistungen- Differentialgetriebe

	<b>E70</b>	<b>E100</b>	<b>E125</b>	<b>E160</b>	<b>E180</b>	<b>E225</b>
	14	43	65	110	215	330
PD [kW] (1450 rpm)	7.5	15	30	55	75	200
T1D [Nm]	49	99	198	362	494	1317

**1.10 Momenti d'inerzia**

**1.10 Moments of inertia**

**1.10 Trägheitsmomente**

<b>RXP 3</b> 		<b>802</b>	<b>804</b>	<b>806</b>	<b>808</b>	<b>810</b>	<b>812</b>	<b>814</b>	<b>816</b>	<b>818</b>	<b>820</b>	<b>822</b>	<b>824</b>
ir	—	31.7	33.5	33.5	29.4	31.7	31.2	31.7	33.5	33.5	29.4	31.7	31.2
J1	kgm <sup>2</sup>	0.00004	0.00006	0.00023	0.00027	0.0008	0.0012	0.0019	0.0034	0.0059	0.0112	0.0197	0.0347
ir	—	35.6	37.6	39.8	34.8	37.7	35.1	35.6	37.6	37.5	34.8	37.7	35.1
J1	kgm <sup>2</sup>	0.00004	0.00006	0.00021	0.00026	0.0007	0.0011	0.0018	0.0032	0.0056	0.0105	0.0185	0.0327
ir	—	40.2	42.4	42.2	39.2	42.6	39.6	40.2	42.4	42.2	39.2	42.6	39.6
J1	kgm <sup>2</sup>	0.00004	0.00006	0.00020	0.00024	0.0007	0.0011	0.0017	0.0031	0.0053	0.0099	0.0174	0.0308
ir	—	45.7	48.2	47.7	44.2	45.4	45.0	45.7	48.2	47.7	44.2	48.4	45.0
J1	kgm <sup>2</sup>	0.00004	0.00006	0.00018	0.00024	0.0006	0.0010	0.0016	0.0029	0.0050	0.0093	0.0164	0.0290
ir	—	52.4	51.5	54.3	47.1	51.8	51.6	52.4	51.5	54.4	47.1	51.8	51.6
J1	kgm <sup>2</sup>	0.00004	0.00006	0.00017	0.00023	0.0006	0.0009	0.0015	0.0027	0.0047	0.0087	0.0155	0.0273
ir	—	56.3	59.2	58.1	57.6	55.5	55.4	56.3	59.2	58.1	53.8	55.5	55.4
J1	kgm <sup>2</sup>	0.00004	0.00006	0.00016	0.00022	0.0005	0.0009	0.0014	0.0026	0.0045	0.0082	0.0146	0.0257
ir	—	60.6	63.8	67.1	66.6	64.2	64.4	60.6	63.8	57.1	61.9	64.2	64.4
J1	kgm <sup>2</sup>	0.00003	0.00006	0.00015	0.00021	0.0005	0.0008	0.0013	0.0024	0.0042	0.0077	0.0137	0.0242
ir	—	71.0	74.7	72.5	78.1	75.2	69.9	71.0	74.7	72.5	72.0	75.2	69.9
J1	kgm <sup>2</sup>	0.00003	0.00006	0.00014	0.00020	0.0005	0.0008	0.0013	0.0023	0.0040	0.0073	0.0129	0.0228
ir	—	77.3	81.3	85.5	85.0	81.9	83.3	77.3	81.3	85.5	78.1	81.9	83.3
J1	kgm <sup>2</sup>	0.00003	0.00006	0.00013	0.00019	0.0004	0.0007	0.0012	0.0021	0.0038	0.0069	0.0121	0.0215
ir	—	84.6	89.0	93.5	93.0	89.6	88.3	84.6	89.0	93.5	93.0	89.6	91.7
J1	kgm <sup>2</sup>	0.00003	0.00006	0.00012	0.00018	0.0004	0.0007	0.0011	0.0020	0.0035	0.0064	0.0114	0.0203
ir	—	101	102	102	105	98.0	99.6	101	96.3	96.1	105	98.0	99.8
J1	kgm <sup>2</sup>	0.00003	0.00006	0.00011	0.00018	0.0004	0.0006	0.0011	0.0019	0.0034	0.0061	0.0108	0.0191
ir	—	115	115	108	112	118	113	115	109	108	112	111	113
J1	kgm <sup>2</sup>	0.00003	0.00005	0.00010	0.00017	0.0003	0.0006	0.0010	0.0018	0.0032	0.0057	0.0101	0.0180
ir	—	132	123	122	128	135	130	132	123	122	128	126	130
J1	kgm <sup>2</sup>	0.00003	0.00005	0.00009	0.00016	0.0003	0.0005	0.0009	0.0017	0.0030	0.0054	0.0095	0.0169
ir	—	142	142	139	137	144	140	142	152	139	147	144	140
J1	kgm <sup>2</sup>	0.00003	0.00005	0.00009	0.00016	0.0003	0.0005	0.0009	0.0016	0.0028	0.0051	0.0090	0.0160
ir	—	153	152	172	158	167	162	153	163	172	171	167	162
J1	kgm <sup>2</sup>	0.00003	0.00005	0.00008	0.00015	0.0003	0.0005	0.0008	0.0015	0.0027	0.0048	0.0085	0.0150
ir	—	179	178	186	186	195	176	179	191	186	186	195	176
J1	kgm <sup>2</sup>	0.00003	0.00004	0.00008	0.00014	0.0003	0.0005	0.0008	0.0014	0.0025	0.0045	0.0080	0.0142
ir	—	195	194	219	202	213	192	195	208	219	202	213	210
J1	kgm <sup>2</sup>	0.00003	0.00004	0.00008	0.00013	0.0002	0.0004	0.0008	0.0013	0.0024	0.0042	0.0075	0.0133
ir	—	213	213	239	221	233	210	213	228	239	221	233	231
J1	kgm <sup>2</sup>	0.00003	0.00004	0.00007	0.00013	0.0002	0.0004	0.0007	0.0013	0.0022	0.0040	0.0071	0.0125
ir	—	243	270	240	236	255	239	243	270	247	243	255	248
J1	kgm <sup>2</sup>	0.00002	0.00004	0.00007	0.00012	0.0002	0.0004	0.0007	0.0012	0.0021	0.0037	0.0067	0.0119
ir	—	299	290	278	273	273	294	299	290	265	279	273	266
J1	kgm <sup>2</sup>	0.00002	0.00004	0.00006	0.00011	0.0002	0.0004	0.0006	0.0011	0.0020	0.0035	0.0063	0.0112
ir	—	322	340	300	320	316	343	322	340	306	325	316	309
J1	kgm <sup>2</sup>	0.00002	0.00003	0.00006	0.00011	0.0002	0.0003	0.0006	0.0011	0.0019	0.0034	0.0060	0.0107
ir	—	378	370	354	349	370	372	378	370	330	352	370	336
J1	kgm <sup>2</sup>	0.00002	0.00003	0.00006	0.00011	0.0002	0.0003	0.0006	0.0010	0.0018	0.0033	0.0058	0.0103
ir	—	411	405	387	420	403	405	411	405	389	384	403	400
J1	kgm <sup>2</sup>	0.00002	0.00003	0.00006	0.00010	0.0002	0.0003	0.0006	0.0010	0.0018	0.0032	0.0057	0.0101
ir	—	450	444	425	466	441	443	450	444	426	420	441	440
J1	kgm <sup>2</sup>	0.00002	0.00003	0.00006	0.00010	0.0002	0.0003	0.0006	0.0010	0.0017	0.0031	0.0055	0.0098
ir	—	495	494	518	512	485	488	495	494	518	512	485	488
J1	kgm <sup>2</sup>	0.00002	0.00003	0.00006	0.00009	0.0002	0.0003	0.0005	0.0010	0.0017	0.0030	0.0054	0.0095
ir	—	549	542	568	561	537	540	549	542	568	561	537	531
J1	kgm <sup>2</sup>	0.00002	0.00003	0.00005	0.00009	0.0002	0.0003	0.0005	0.0009	0.0017	0.0030	0.0053	0.0094

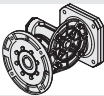
<b>E</b> 		<b>70</b>	<b>100</b>	<b>125</b>	<b>160</b>	<b>180</b>	<b>225</b>
J1	kgm <sup>2</sup>	0.0002	0.0013	0.0032	0.0072	0.0201	0.0478



1.11 Dimensioni  
Materiale Carcassa - "Ghisa"

1.11 Dimensions  
Housing Material- "Cast Iron"

1.11 Abmessungen  
Gehäusematerial - "Guss"

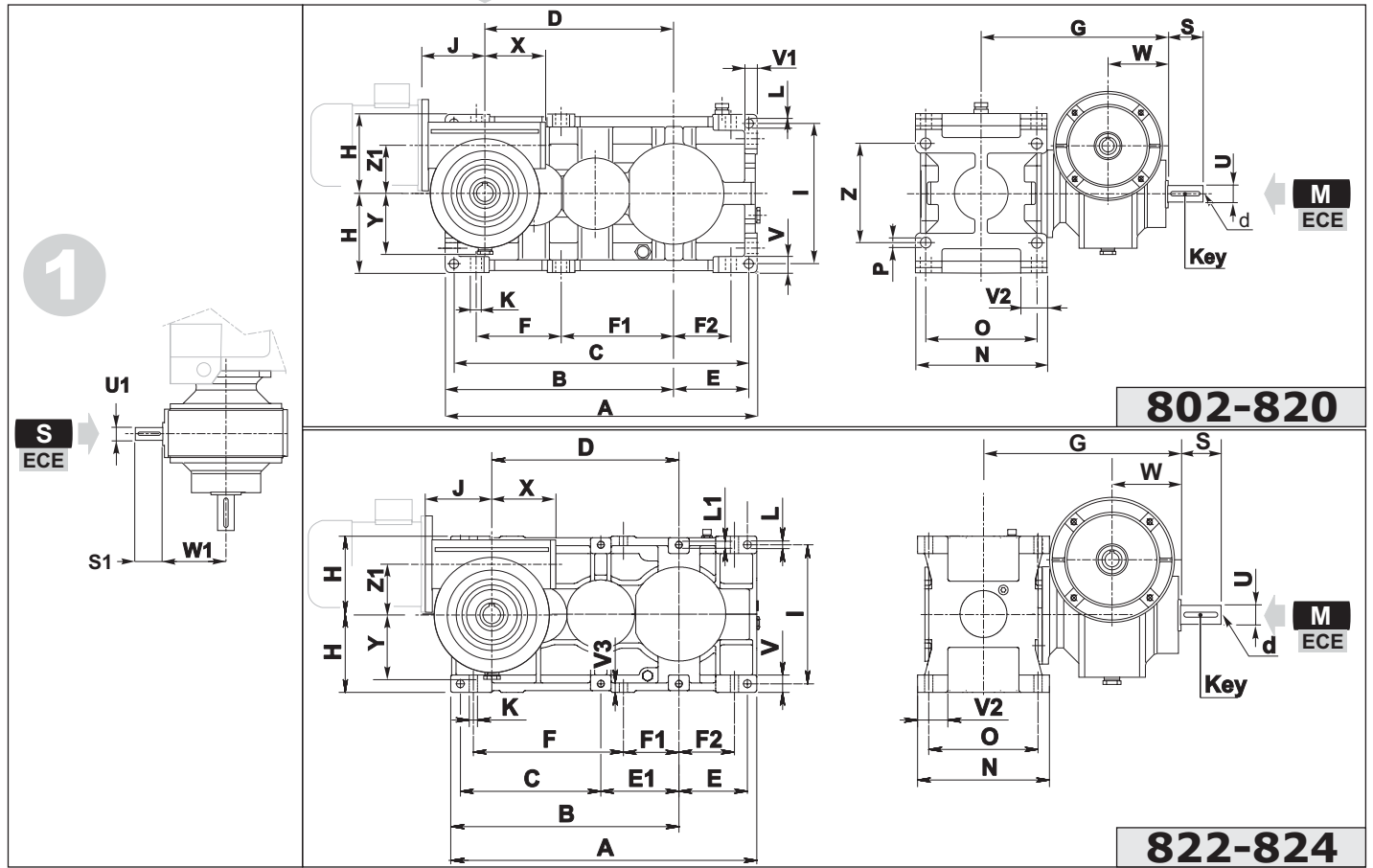

➔ **N D FD Fn**

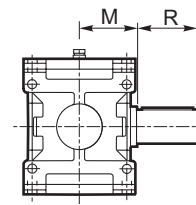
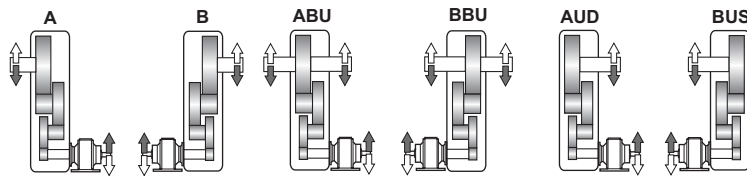

**N**

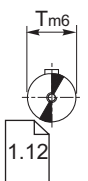

1.12

➔ **C**

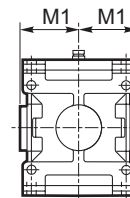
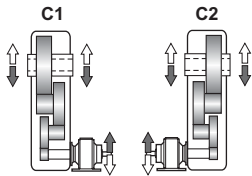

**C**



1.12

➔ **UB B CD**

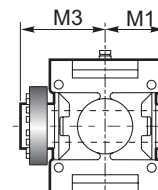
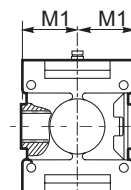
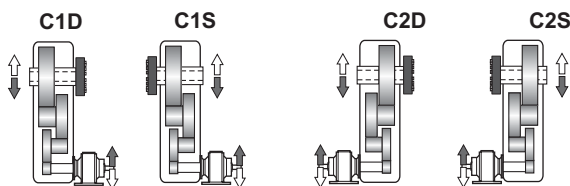

**UB**



1.12





**1.11 Dimensioni**  
Materiale Carcassa - "Ghisa"

**1.11 Dimensions**  
Housing Material- "Cast Iron"

**1.11 Abmessungen**  
Gehäusematerial - "Guss"

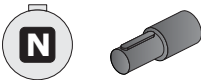
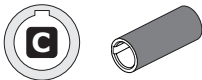
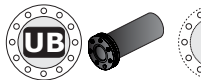
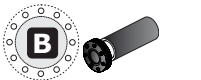
	Dimensioni generali / Dimensions / Allgemeine Abmessungen																				Kg		
	A	B	C	D	E	E1	F	F1	F2	H <sub>h11</sub>	I	K	L	L1	N <sub>h11</sub>	O	P	V	V1	V2		V3	Z
<b>802</b>	498	368	470	305	116	—	136	182	90	125	224	18	14	—	213	180	18	25	20	44.5	19	160	99
<b>804</b>	562	412	530	342	134	—	153	202.5	103.5	140	250	20	16	—	237	200	20	28	22.5	49	23	180	128
<b>806</b>	635	465	601	385	153	—	173	229	117	160	280	22	18	—	269	225	22	32	25	56.5	25	200	193
<b>808</b>	712	522	674	432	171	—	194	258	130	180	320	25	20	—	297	250	25	36	28	59.5	28	224	273
<b>810</b>	795	585	755	485	190	—	216	288	144	200	360	27	22	—	335	280	27	40	32	67.5	32	250	382
<b>812</b>	897	657	852	545	217.5	—	242	324.5	159.5	225	400	30	24	—	379	315	30	45	36	78.5	36	280	534
<b>814</b>	1000	735	950	610	240	—	271	363	179	250	450	33	27	—	427	355	33	50	40	89	40	320	758
<b>816</b>	1125	825	1069	685	272	—	305	407.5	202.5	280	500	36	30	—	479	400	36	56	45	96.5	45	360	1045
<b>818</b>	1270	930	1206	770	308	—	345	460	230	315	560	39	35	—	541	450	39	63	50	114.5	48	400	1464
<b>820</b>	1425	1045	1353	865	344	—	388	516.5	259.5	355	638	42	39	—	599	500	42	70	56	124	56	450	2049
<b>822</b>	1570	1170	1520	970	350	400	770	300	300	400	710	45	42	M39	675	560	-	90	-	162	50	-	3000
<b>824</b>	1765	1315	810	1090	395	450	865	320	320	450	800	48	45	M42	761	630	-	100	-	175	55	-	4100

	Albero uscita / Output shaft / Abtriebswelle									
										
	T m6	R	M	T H7	M1	T H7	M1	M3		
<b>802</b>	60	112	109	60	109	60	109	170		
<b>804</b>	70	125	121	70	121	70	121	192		
<b>806</b>	80	140	137	80	137	80	137	215		
<b>808</b>	90	160	151	90	151	90	151	246		
<b>810</b>	100	180	170	100	170	100	170	266		
<b>812</b>	110	200	192	110	192	110	192	302		
<b>814</b>	125	225	216	125	216	125	216	335		
<b>816</b>	140	250	242	140	242	140	242	370		
<b>818</b>	160	280	273	160	273	160	273	422		
<b>820</b>	180	315	302	180	302	180	302	477		
<b>822</b>	209	355	340	200	340	200	340	570		
<b>824</b>	220	400	383	220	383	220	383	617		

		E70	E100	E125	E160	E180	E225
<b>M</b> <b>ECE</b>	<b>802</b>	418.5	407.5				
	<b>804</b>	430.5	419.5	478.5			
	<b>806</b>	448.5	437.5	496.5			
	<b>808</b>	462.5	451.5	510.5	590.5		
	<b>810</b>	461.5	450.5	509.5	611.5		
	<b>812</b>	482.5	471.5	530.5	633.5	648	
	<b>814</b>		497	556	657.5	650	784
	<b>816</b>		522.5	581.5	686.5	700	808
	<b>818</b>			611.5	684.5	624	840
	<b>820</b>				714.5	649	880
	<b>822</b>				530	679	750
<b>S</b> <b>ECE</b>	<b>824</b>					714	785
	<b>d</b>	M6x18	M8x21	M10x27	M16x39	M16x39	M16x39
	<b>Key</b>	8x7x40	10x8x70	14x9x100	16x10x100	20x12x110	22x14x125
	<b>U</b>	28 j6	38 k6	48 k6	55 m6	70 m6	80 m6
	<b>S</b>	50	80	110	110	125	140
	<b>W</b>	120	138	154	172	240	290
	<b>U1</b>	19 j6	28 j6	38 j6	42 j6	55 m6	60 m6
	<b>S1</b>	40	60	80	100	100	112
<b>W1</b>	97	146	166	195	240	290	
<b>X</b>	92	142	163	191	238	280	
<b>Y</b>	84	139	152	177	212	247	
<b>Z1</b>	70	110	130	150	180	215	

**1.11 Dimensioni**  
Materiale Carcassa - "Acciaio"

**1.11 Dimensions**  
Housing Material- "Steel"

**1.11 Abmessungen**  
Gehäusematerial - "Stahl"

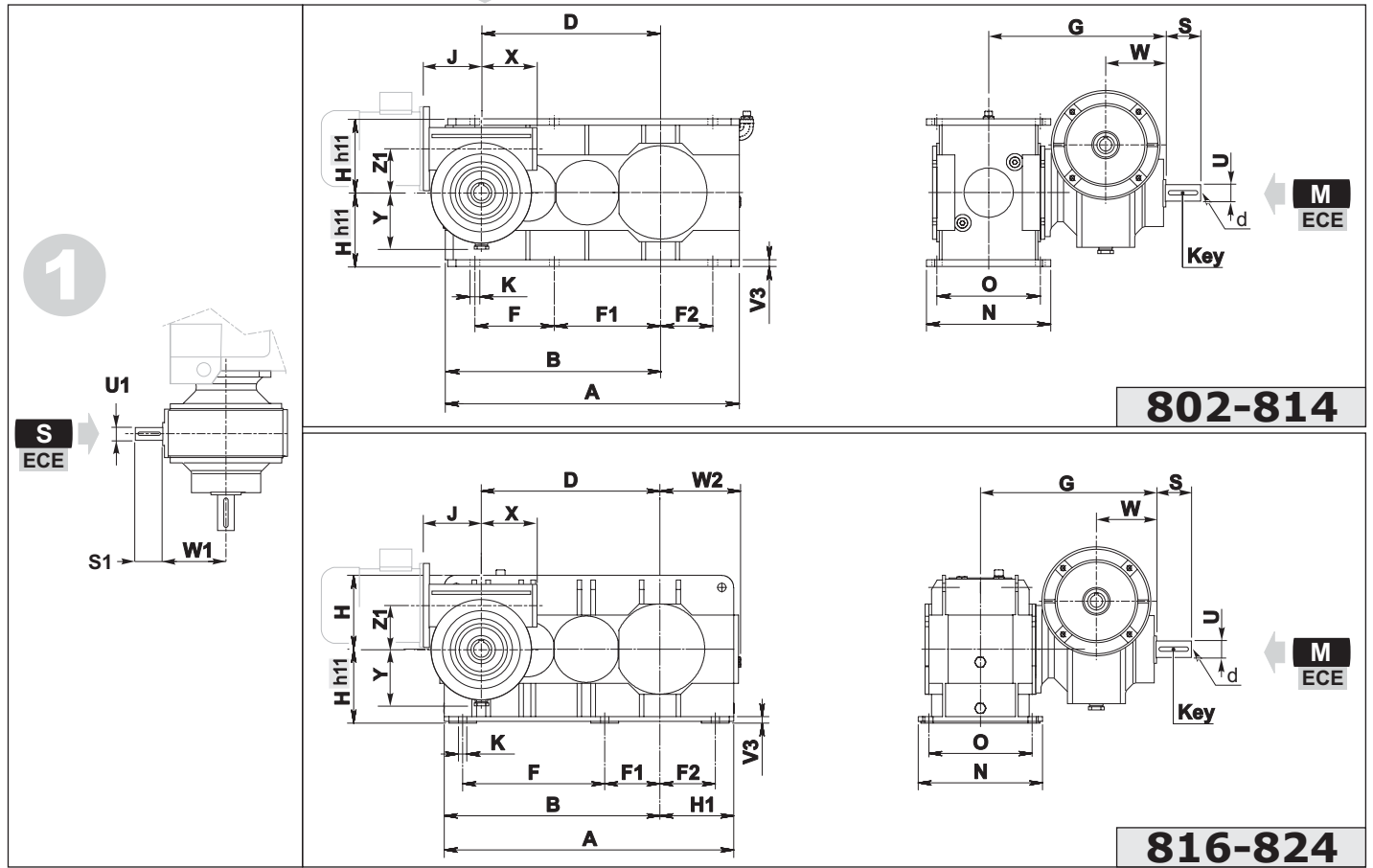

**N D FD Fn**

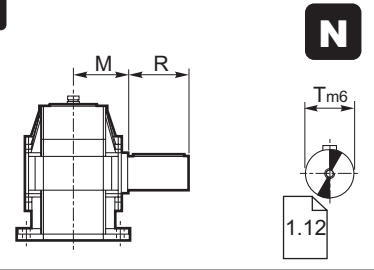
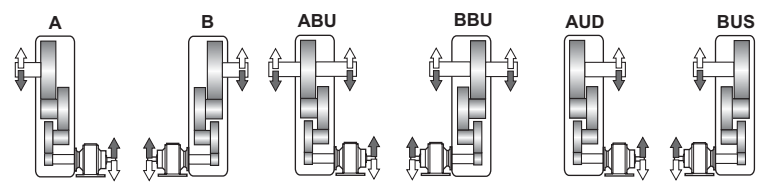

**C**

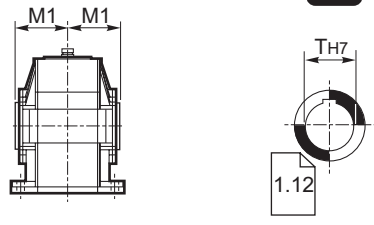
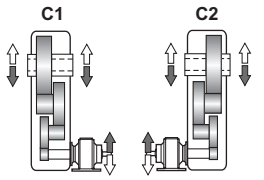

**UB B CD**

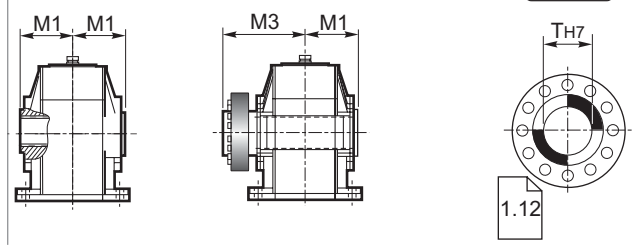
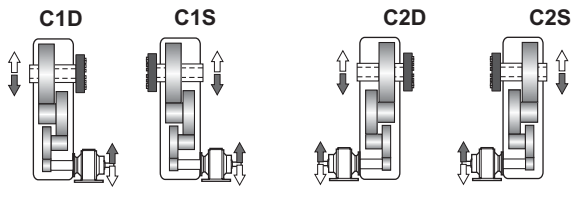



**1.11 Dimensioni**  
Materiale Carcassa - "Acciaio"

**1.11 Dimensions**  
Housing Material- "Steel"

**1.11 Abmessungen**  
Gehäusematerial - "Stahl"

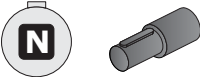
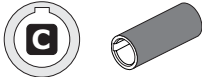
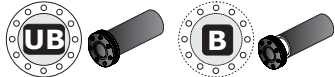
	Dimensioni generali / Dimensions / Allgemeine Abmessungen													
	A	B	D	F	F1	F2	H	H1	K	N	O	V3	W2	kg
802	498	368	305	136	182	90	125	125	18	213	180	10	-	99
804	562	412	342	153	202.5	103.5	140	140	20	237	200	12	-	128
806	635	465	385	173	229	117	160	160	22	269	225	15	-	193
808	712	522	432	194	258	130	180	180	25	297	250	15	-	273
810	795	585	485	216	288	144	200	200	27	335	280	20	-	382
812	897	657	545	242	324.5	159.5	225	225	30	379	315	20	-	534
814	1000	735	610	271	363	179	250	250	33	427	355	20	-	758
816	1105	825	685	305	407.5	202.5	280	280	36	479	400	30	318	1045
818	1245	930	770	345	460	230	315	315	39	541	450	30	357	1464
820	1400	1045	865	388	516.5	259.5	355	355	42	599	500	30	407	2106
822	1570	1170	970	770	300	300	400	400	45	675	560	35	437	3000
824	1635	1255	1090	865	320	320	450	380	48	761	630	37	480	4000

	Albero uscita / Output shaft / Abtriebswelle								
									
	T m6	R	M	T H7	M1	T H7	M1	M3	
802	60	112	109	60	109	60	109	170	
804	70	125	121	70	121	70	121	192	
806	80	140	137	80	137	80	137	215	
808	90	160	151	90	151	90	151	246	
810	100	180	170	100	170	100	170	266	
812	110	200	192	110	192	110	192	302	
814	125	225	216	125	216	125	216	335	
816	140	250	242	140	242	140	242	370	
818	160	280	273	160	273	160	273	422	
820	180	315	302	180	302	180	302	477	
822	209	355	340	200	340	200	340	570	
824	220	400	383	220	383	220	383	617	

		E70	E100	E125	E160	E180	E225
<b>M</b> <b>ECE</b>	802	418.5	407.5				
	804	430.5	419.5	478.5			
	806	448.5	437.5	496.5			
	808	462.5	451.5	510.5	590.5		
	810	461.5	450.5	509.5	611.5		
	812	482.5	471.5	530.5	633.5	648	
	814		497	556	657.5	650	784
	816		522.5	581.5	686.5	700	808
	818			611.5	684.5	624	840
	820				714.5	649	880
	822				530	679	750
824					714	785	
<b>S</b> <b>ECE</b>	<b>d</b>	M6x18	M8x21	M10x27	M16x39	M16x39	M16x39
	<b>Key</b>	8x7x40	10x8x70	14x9x100	16x10x100	20x12x110	22x14x125
	<b>U</b>	28 j6	38 k6	48 k6	55 m6	70 m6	80 m6
	<b>S</b>	50	80	110	110	125	140
	<b>W</b>	120	138	154	172	240	290
	<b>U1</b>	19 j6	28 j6	38 j6	42 j6	55 m6	60 m6
	<b>S1</b>	40	60	80	100	100	112
<b>W1</b>	97	146	166	195	240	290	
<b>X</b>	92	142	163	191	238	280	
<b>Y</b>	84	139	152	177	212	247	
<b>Z1</b>	70	110	130	150	180	215	

### 1.11 Dimensioni

### 1.11 Dimensions

### 1.11 Abmessungen

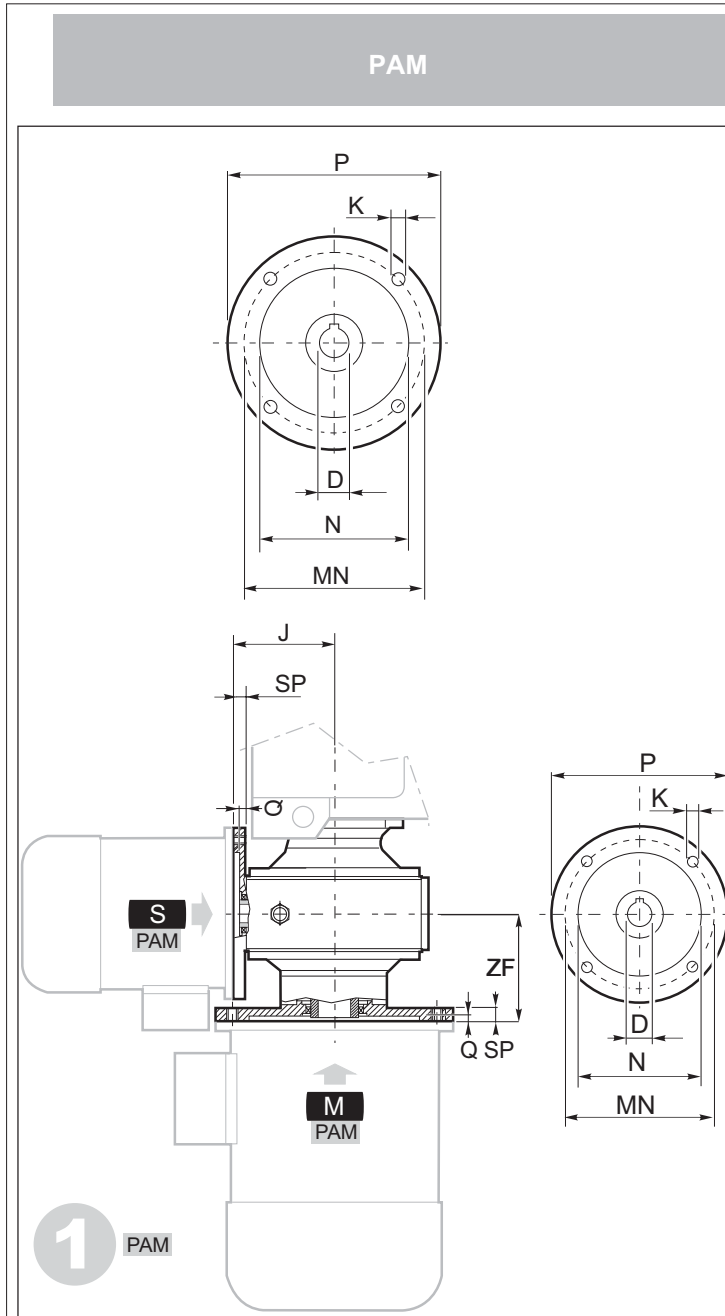

M PAM	Grandezza riduttore accoppiato - RXP3 Coupled gear unit - RXP3 Gepasstes Getriebe - RXP3												
	IEC	802	804	806	808	810	812	814	816	818	820	822	824
E70	ZF												
	90	121	121	121	121	121	121						
	100												
	112												
E100	132		157	157	157	157	157	157	157				
	160												
E125	160				173	173	173	173	173				
	180												
E160	180								204	204	204		
	200												
E180	200									250	250	250	250
	225												

S PAM	Grandezza riduttore accoppiato - RXP3 Coupled gear unit - RXP3 Gepasstes Getriebe - RXP3												
	IEC	802	804	806	808	810	812	814	816	818	820	822	824
E70	J												
	71												
	80	100	100	100	100	100	100						
E100	90	145	145										
	100			145	145	145	145	145	145				
	112												
E125	100		163	163	163								
	112					163	163	163	163				
	132												
E160	100				190	190							
	112						190	190	190	190	190	190	
	132												
	160								197	197	197	197	
E180	100												
	112												
	132							245	245	245	245	245	245
	160												
E225	180												
	132								285	285	285	285	285
	160												
	180												
200													

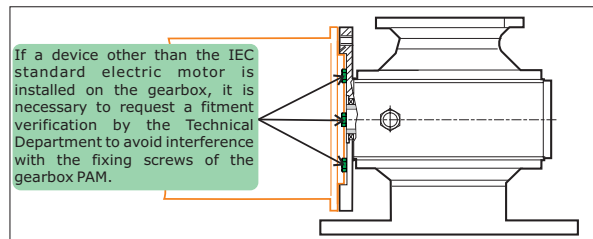

IEC	P	MN	N G6	Q	K	SP	D
71	160	130	110	4.5	Look at tables	12	14
80	200	165	130	4.5		12	19
90	200	165	130	4.5		12	24
100	250	215	180	5		14	28
112	250	215	180	5		14	28
132	300	265	230	5		16	38
160	350	300	250	6		18	42
180	350	300	250	6		18	48
200	400	350	300	6		20	55
225	450	400	350	6		20	60

M PAM	IEC	K
E70	90	N.4 Ø11
	100	N.4 M12
	112	N.4 M12
E100	132	N.4 M12
	160	N.4 M16
E125	160	N.4 M16
	180	N.4 M16
E160	180	N.4 Ø19
	200	N.4 Ø19
	200	N.4 M16
E180	200	N.4 M16
	225	N.8 M16











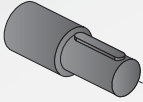

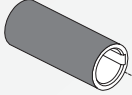
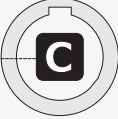
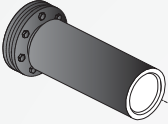
S PAM	IEC	K
E70	71	N.4 Ø9
	80	N.4 Ø11
	90	N.4 Ø11
E100	90	N.4 Ø11
	100	N.4 M12
	112	N.4 M12
E125	100	N.4 M12
	112	N.4 M12
	132	N.4 M12
E160	100	N.4 M12
	112	N.4 M12
	132	N.4 M12
	160	N.4 M16
E180	100	N.4 M12
	112	N.4 M12
	132	N.4 M12
	160	N.4 M16
	180	N.4 M16
E225	132	N.4 M12
	160	N.4 M16
	180	N.4 M16
	200	N.4 M16

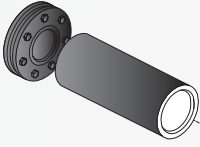
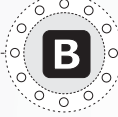
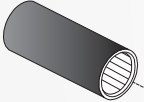
1.12 - ESTREMITÀ USCITA  
 1.12 - OUTPUT CONFIGURATIONS  
 1.12 - ENDEN DER AUSGANGSWELLEN

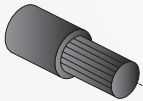

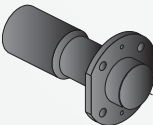
STIM  
team

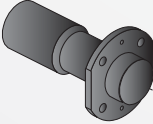
STIM  
team

		Output shaft	A40
		Hollow shaft	A41
		Hollow output shaft with shrink disc	A42
		Hollow output shaft with shrink disc	A42
		Splined hollow shaft	A43
		Splined output shaft without broached flange	A44
		Splined output shaft and broached flange	A44
		Splined output shaft with flanged coupling	A45



1.12.1 - Sporgente Integrale

1.12.1 - Output shaft

1.12.1 - Vollwelle

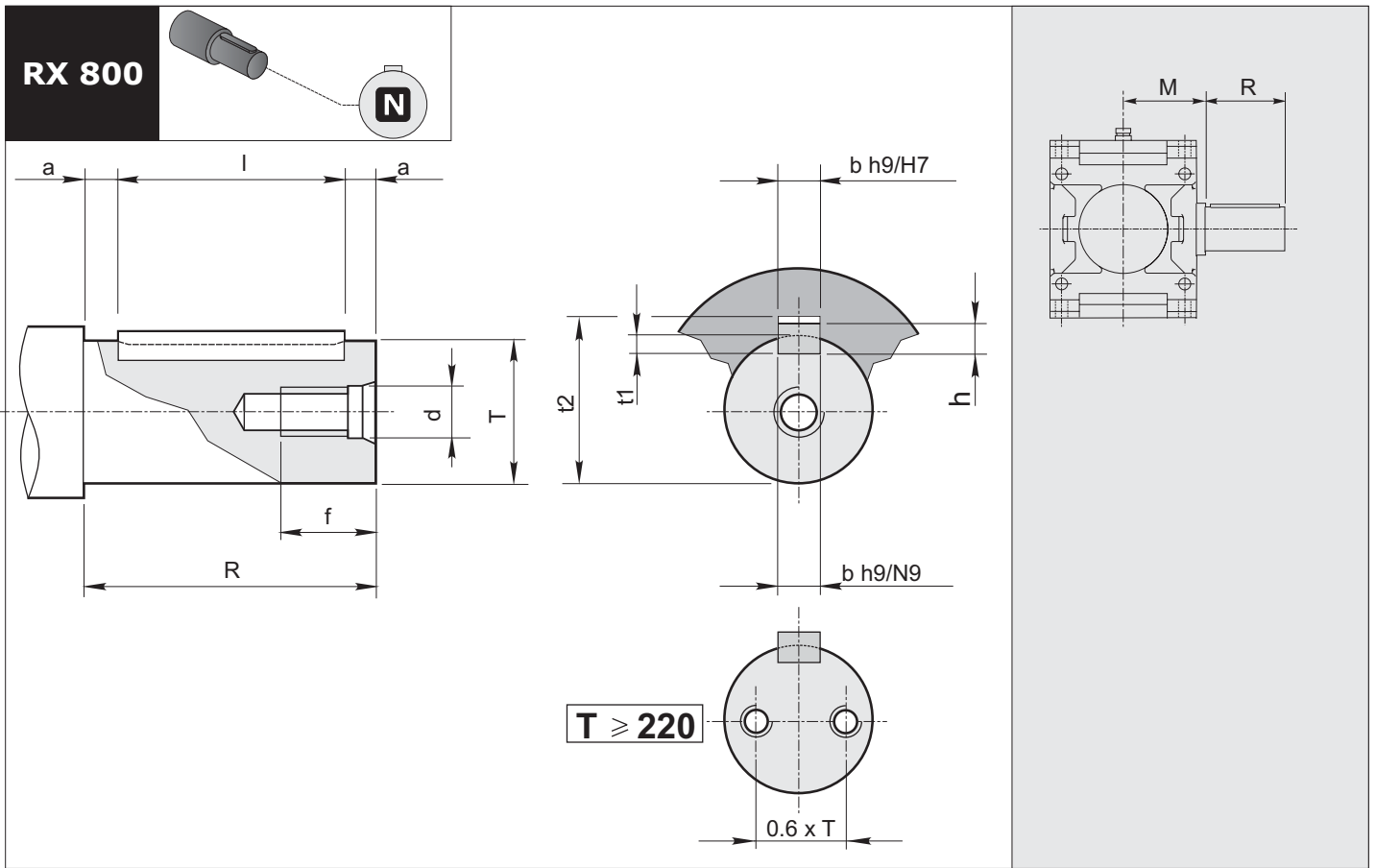

RX. Series	Ø Albero Ø Shaft Ø Welle		Foro fil. testa Tapped hole Gewindebohrung Kopf		Cava Keyway Nut			Estremità d'albero Shaft end Wellenende		Linguetta Key Federkeil
	T	M	d	f	b	t <sub>1</sub>	t <sub>2</sub>	R a11	a	bxhxl
802	60 m6	109	M12	35	18	7	64.4	112	6	18x11x100
804	70 m6	121	M16	39	20	7.5	74.9	125	7.5	20x12x110
806	80 m6	137	M16	39	22	9	85.4	140	7.5	22x14x125
808	90 m6	151	M16	39	25	9	95.4	160	10	25x14x140
810	100 m6	170	M20	46	28	10	106.4	180	10	28x16x160
812	110 m6	192	M20	46	28	10	116.4	200	10	28x16x180
814	125 m6	216	M20	46	32	11	132.4	225	12.5	32x18x200
816	140 m6	242	M24	56	36	12	148.4	250	15	36x20x220
818	160 m6	273	M24	56	40	13	169.4	280	15	40x22x250
820	180 m6	302	M30	72	45	15	190.4	315	17.5	45x25x280
822	200 m6	340	M30	72	45	15	210.4	355	17.5	45x25x320
824	220 m6	383	N°2 M24	56	50	17	231.4	400	20	50x28x360

Estremità d'albero cilindriche secondo UNI 6397-68, DIN748, NFE 22.051, BS 4506-70, ISO/R 775/69, escluso corrispondenza R-S.  
Linguette secondo UNI6604-69, DIN6885 Bl. 1-68, NFE 27.656 e 22.175, BS 4235.1-72, ISO/R 773/69, escluso corrispondenza I.

Cylindrical shaft ends in accordance with UNI 6397-68, DIN748, NFE 22.051, BS 4506-70, ISO/R 775/69, excluding section R-S.  
Key according to UNI6604-69, DIN6885 Bl. 1-68, NFE 27.656 e 22.175, BS 4235.1-72, ISO/R 773/69, excluding section I.

Zylindrische Wellenenden gemäß UNI 6397-68, DIN748, NFE 22.051, BS 4506-70, ISO/R 775/69, ausgenommen Zuordnung R-S.  
Federkeile UNI6604-69, DIN6885 Bl. 1-68, NFE 27.656 und 22.175, BS 4235.1-72, ISO/R 773/69, ausgenommen Zuordnung I.

1.12.2 - Albero cavo

1.12.2 - Hollow shaft

1.12.2 - Hohlwelle

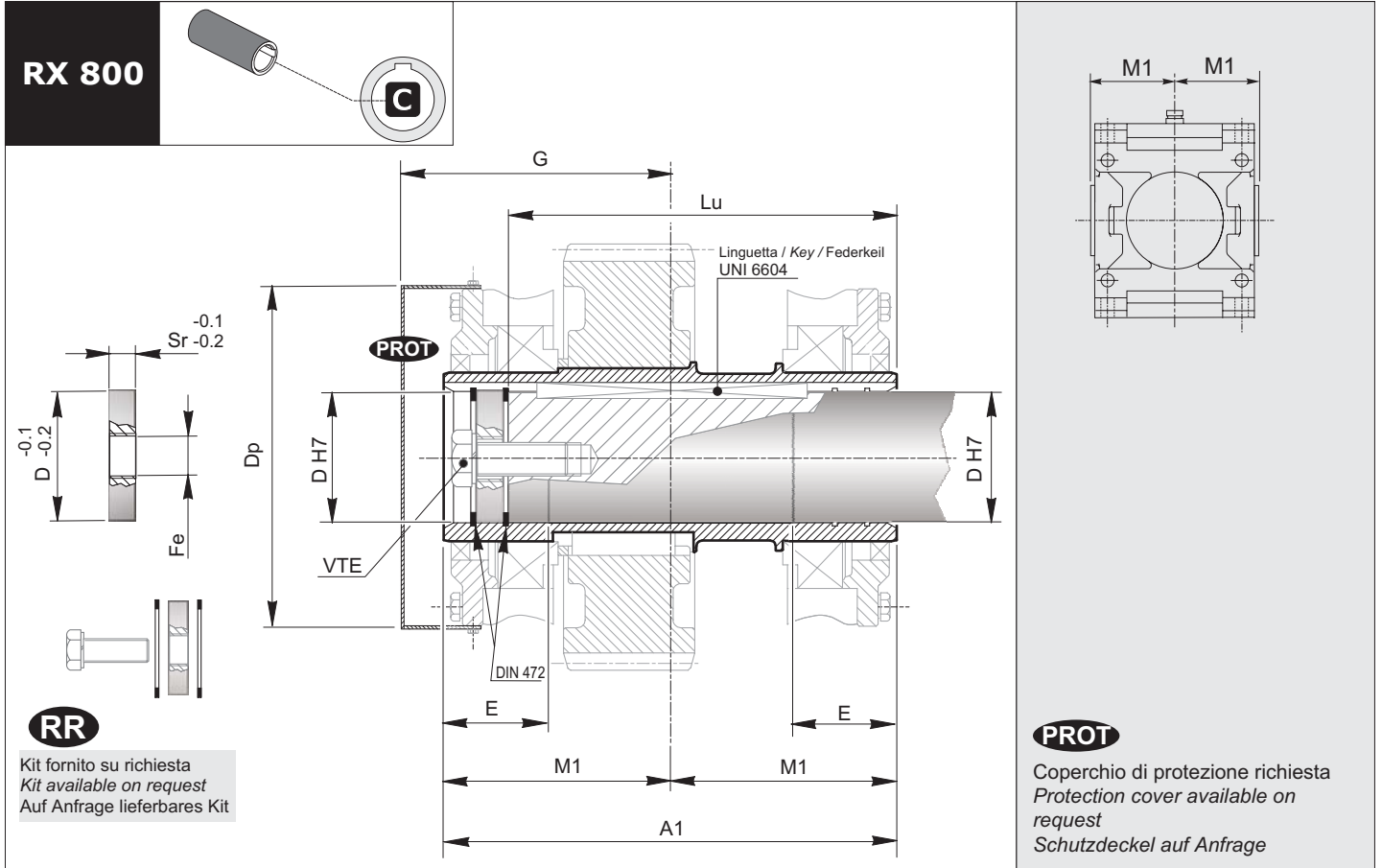

RX 800 Series	A1	M1	D	Dp	E	Fe	G	Lu	Sr
802	218	109	60	165	50	M27	120	184	15
804	242	121	70	184	56	M27	135	207.5	15
806	274	137	80	208	63	M27	150	239.5	15
808	302	151	90	234	70	M30	170	261	18
810	340	170	100	254	80	M30	190	299	18
812	384	192	110	290	90	M30	210	339	21
814	432	216	125	316	100	M30	235	384	24
816	484	242	140	365	110	M39	260	431	24
818	546	273	160	415	125	M39	295	490	27
820	604	302	180	454	140	M39	325	548	27
822	680	340	200	—	160	M42	—	616	30
824	766	383	220	—	180	M42	—	693	30

Albero macchina / Machine shaft / Machine shaft

	B	C	D	E	F	G	L	Lu	VTE
802	21	3.5	60	55	108	22	160	184	M20
804	26.5	4	70	61	120	25	180	207.5	M20
806	33.5	4.5	80	68	138	36	200	239.5	M20
808	36	5	90	77	148	37	220	261	M24
810	44	5.5	100	85	170	43	250	299	M24
812	50	6	110	95	194	15	320	339	M24
814	61	7	125	105	218	57	320	384	M24
816	62	8	140	115	254	62	360	431	M30
818	74	9	160	130	286	36	450	490	M30
820	89	10	180	145	314	42	500	548	M30
822	100	12	200	165	351	46	560	616	M33
824	112	14	220	185	396	50	630	693	M33

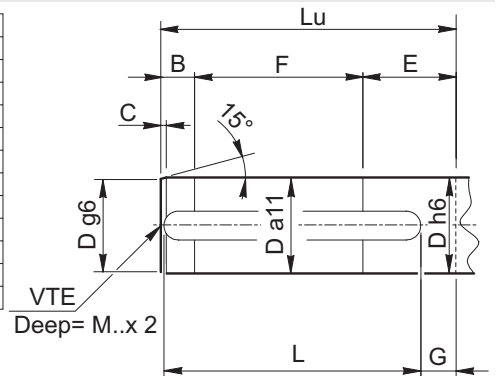

1.12.3 - Albero uscita cavo con unità di bloccaggio  
1.12.3 - Hollow output shaft with shrink disc

1.12.3 - Hohlwelle mit Schrumpfscheibe

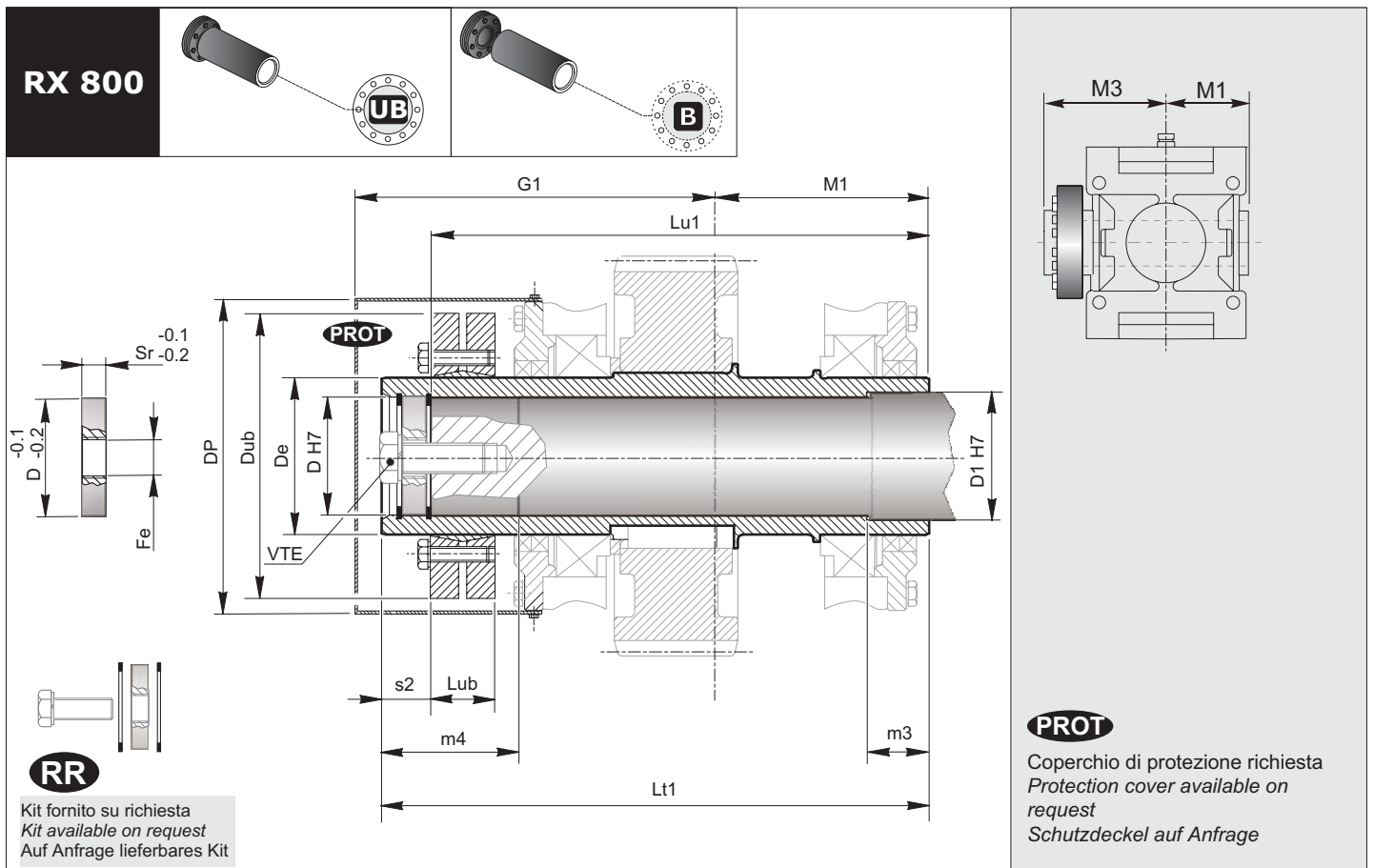

RX 800 Series	D	D1	De	Dp	Dub	Fe	G1	Lt1	Lub	Lu1	M1	M3	m4	m3	Sr	s2
802	60	65	80	165	145	M27	185	279	32.5	254	109	170	70	32	15	25
804	70	75	90	184	155	M27	205	313	39	286	121	192	80	35	15	27
806	80	85	100	208	170	M27	230	352	44	324	137	215	90	40	15	28
808	90	95	120	234	215	M30	260	397	54	364	151	246	100	45	18	33
810	100	110	130	254	215	M30	285	436	54	402	170	266	110	50	18	34
812	110	120	140	290	230	M30	320	494	60.5	454	192	302	125	56	21	40
814	125	135	160	316	265	M30	355	551	64.5	507	216	335	140	63	24	44
816	140	150	180	365	300	M39	390	612	71	567	242	370	160	70	24	45
818	160	170	200	415	350	M39	440	695	86	645	273	422	180	80	27	50
820	180	195	240	454	405	M39	500	779	109	727	302	477	200	90	27	52
822	200	215	260	515	430	M42	600	910	160	852	340	570	225	100	30	58
824	220	235	280	—	460	M42	—	1000	172	938	383	617	253	110	30	62

Albero macchina / Machine shaft / Machine shaft

	B	C	D	D1	E	F	Lu1	M	R	VTE
802	50	3.5	60	65	28	176	254	M20	2	M20
804	58	4	70	75	30	198	286	M20	2.2	M20
806	67	4.5	80	85	32	225	324	M20	2.5	M20
808	72	5	90	95	35	257	364	M24	2.8	M24
810	81	5.5	100	110	40	281	402	M24	3	M24
812	90	6	110	120	45	319	454	M24	3.5	M24
814	101	7	125	135	50	356	507	M24	4	M24
816	120	8	140	150	56	391	567	M30	4.5	M30
818	135	9	160	170	63	447	645	M30	5	M30
820	153	10	180	195	71	503	727	M30	5.5	M30
822	167	11	200	215	80	605	852	M33	6	M33
824	200	14	220	235	90	648	938	M33	6.5	M33

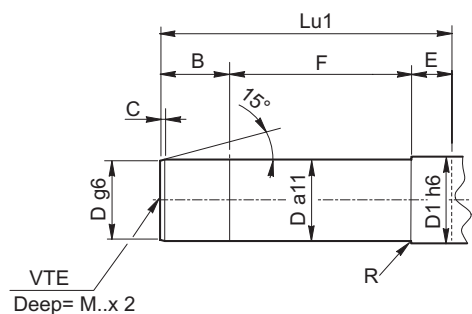

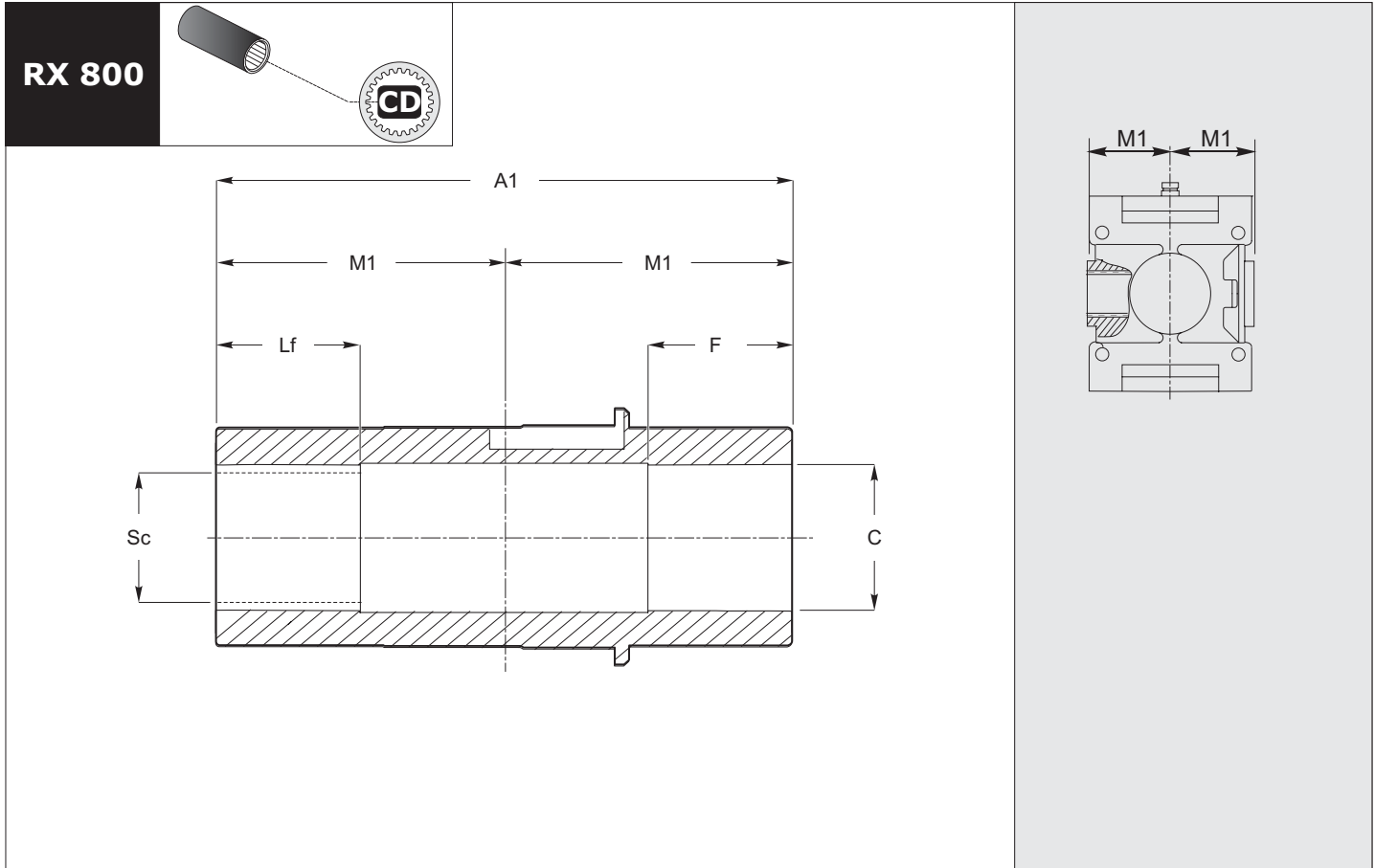

RX 800 Series	A1	M1	C H7	F	Lf	Sc
802	218	109	62	70	70	60 x 55 - DIN5482
804	242	121	72	70	70	70 x 64 - DIN5482
806	274	137	82	90	90	80 x 74 - DIN5482
808	302	151	92	90	90	90 x 84 - DIN5482
810	340	170	102	110	110	100 x 94 - DIN5482
812	384	192	112	110	110	110 x 3 x 35 - DIN5480
814	432	216	122	120	120	120 x 5 x 22 - DIN5480
816	484	242	142	140	140	140 x 5 x 26 - DIN5480
818	546	273	162	160	160	160 x 5 x 30 - DIN5480
820	604	302	182	180	180	180 x 8 x 21 - DIN5480

Albero macchina / Machine shaft / Machine shaft

	d1 h6	m3	H	HS	P	R	Ra	Rb	Sc	F	Lf	Lm	m
802	Contattare il ns. servizio tecnico / Contact our technical dept / Wenden Sie sich an unseren technischen Service												
804													
806													
808													
810													
812													
814													
816													
818													
820													

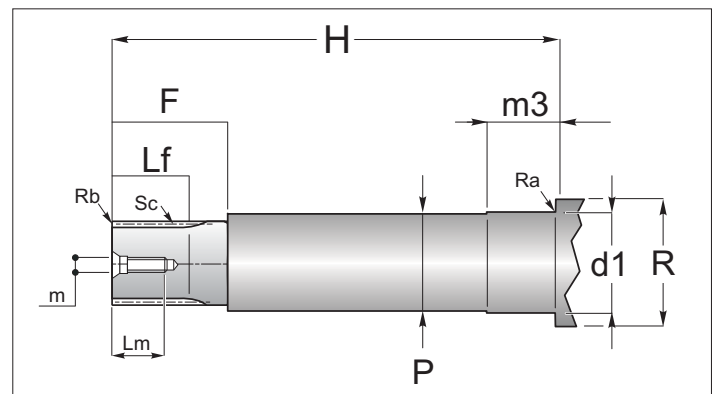

**1.12.5 - Estremità albero lento scanalato senza flangia brocciata**

**1.12.5 - Splined output shaft without broached flange**

**1.12.5 - Abtriebswelle mit Keilende ohne geräumtem Flansch**

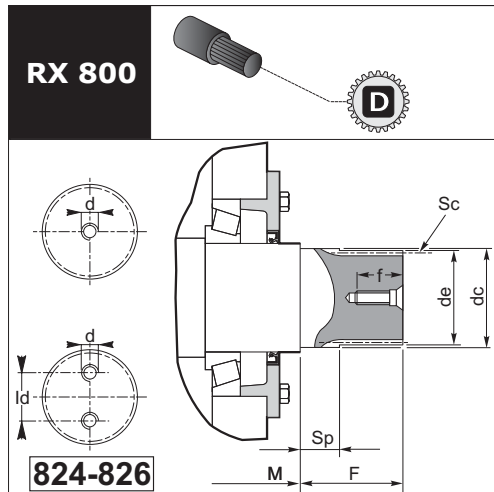

	de (h10)	F	M	Foro fil. testa Tapped hole Gewindebohrung Kopf			Profilo scanalato / Splined profile / Keilprofil					
				d	Id	f	Sc	Z	mn	$\alpha$	dc (f7)	Sp
802	59.5	62	109	M12		35	FIAT 60	22	2.6	30°	60	22
804	69.3	69	121	M16		39	FIAT 70	26	2.58	30°	70	25
806	79.3	69	137	M16		39	FIAT 80	27	2.82	30°	80	20
808	94.3	74	151	M16		39	FIAT 95	31	2.97	30°	95	25
810	104.4	79	170	M20		46	D. 105 DIN 5480	34	3	30°	106	25
812	109.4	94	192	M20		46	D. 110 DIN 5480	35	3	30°	111	25
814	129	124	216	M20		46	D. 130 DIN 5480	24	5	30°	130	32
816	139	139	242	M24		56	D. 140 DIN 5480	26	5	30°	140	35
818	159	159	273	M24		56	D. 160 DIN 5480	30	5	30°	160	38
820	178.4	179	302	M30		71	D. 180 DIN 5480	21	8	30°	180	42
822	198.4	200	340	M30		71	D. 200 DIN 5480	24	8	30°	200	44
824	218.4	218	383	M24	132	48	D. 220 DIN 5480	26	8	30°	220	48



**FF -**  
Kit fornito su richiesta  
Kit available on request  
Auf Anfrage lieferbares Kit

**1.12.6 - Estremità scanalata albero lento flangia brocciata**

**1.12.6 - Splined output shaft and broached flange**

**1.12.6 - Abtriebswelle mit Keilende und geräumtem Flansch**

Non fornibili per classe di sollevamento M8.

Not available for lifting class M8.

Für Hubklass M8 nicht lieferbar.

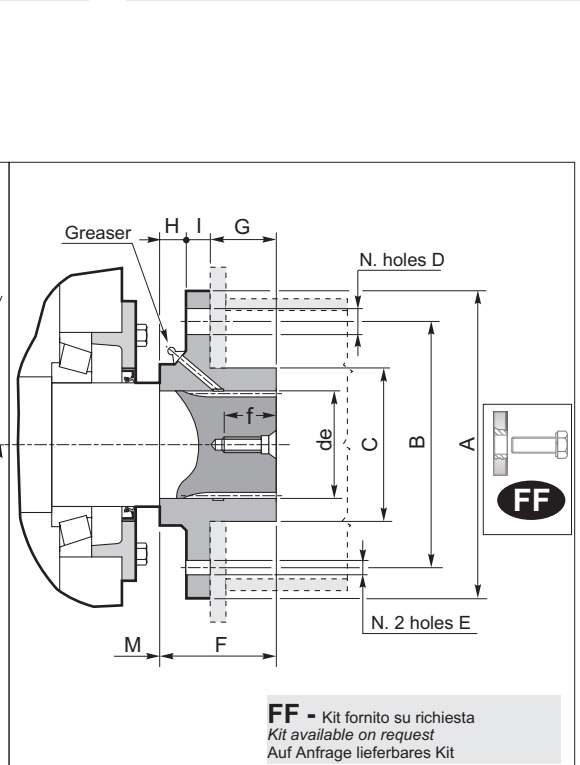
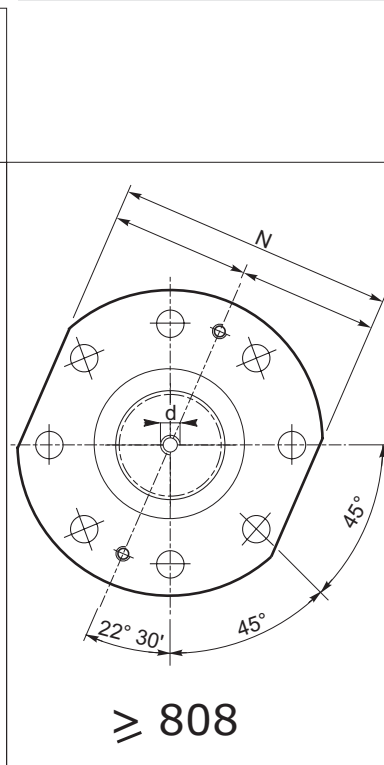
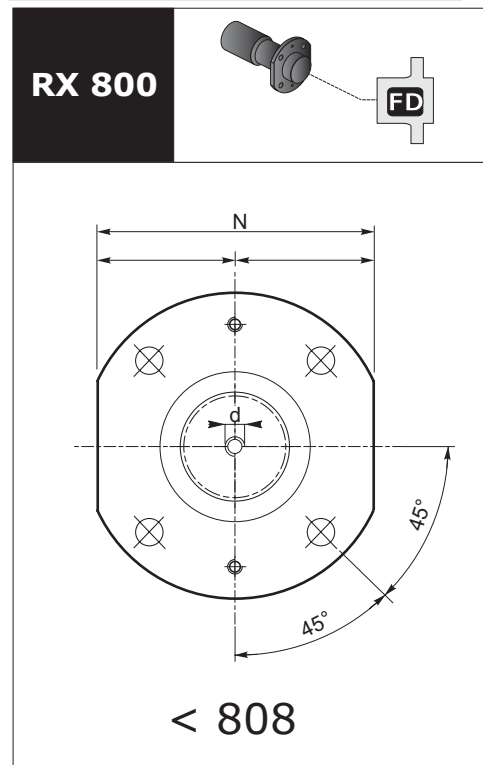

**FF -** Kit fornito su richiesta  
Kit available on request  
Auf Anfrage lieferbares Kit

RX 800 Series	Dimensioni generali / General dimensions / Allgemeine Abmessungen														
	de	Ø A	Ø B	Ø C f8	Foro fil. testa Tapped hole Gewindebohrung Kopf		N° Fori holes Anzahl der Bohrungen	Ø D	E	F	G	H	I	M	N h9
					d	f									
802	60	180	140	90	M12	35	4	17.5	M8	63	38	9	16	109	160
804	70	200	160	100	M16	39	4	17.5	M10	70	43	11	16	121	180
806	80	220	180	110	M16	39	4	19.5	M10	70	40	12	18	137	200
808	95	240	190	130	M16	39	8	19.5	M10	75	40	15	20	151	220
810	105	250	200	145	M20	46	8	21.5	M12	80	40	20	20	170	230
812	110	280	225	150	M20	46	8	21.5	M12	95	52	20	23	192	250
814	130	355	280	180	M20	46	8	23.5	M14	125	80	20	25	216	315
816	140	400	315	200	M24	56	8	23.5	M14	140	90	22	28	242	355
818	160	450	355	225	M24	56	8	29	M16	160	103	25	32	273	400
820	180	500	400	250	M30	71	8	32	M16	180	118	28	34	302	450
822	200	560	450	280	M30	71	8	35	M18	200	132	32	36	340	500



1.12.7 - Estremità scanalata albero lento con giunto dentato flangiato

1.12.7 - *Splined output shaft with flanged splined coupling*

1.12.7 - Abtriebswelle mit Keilende mit geflanschter Klauenkupplung

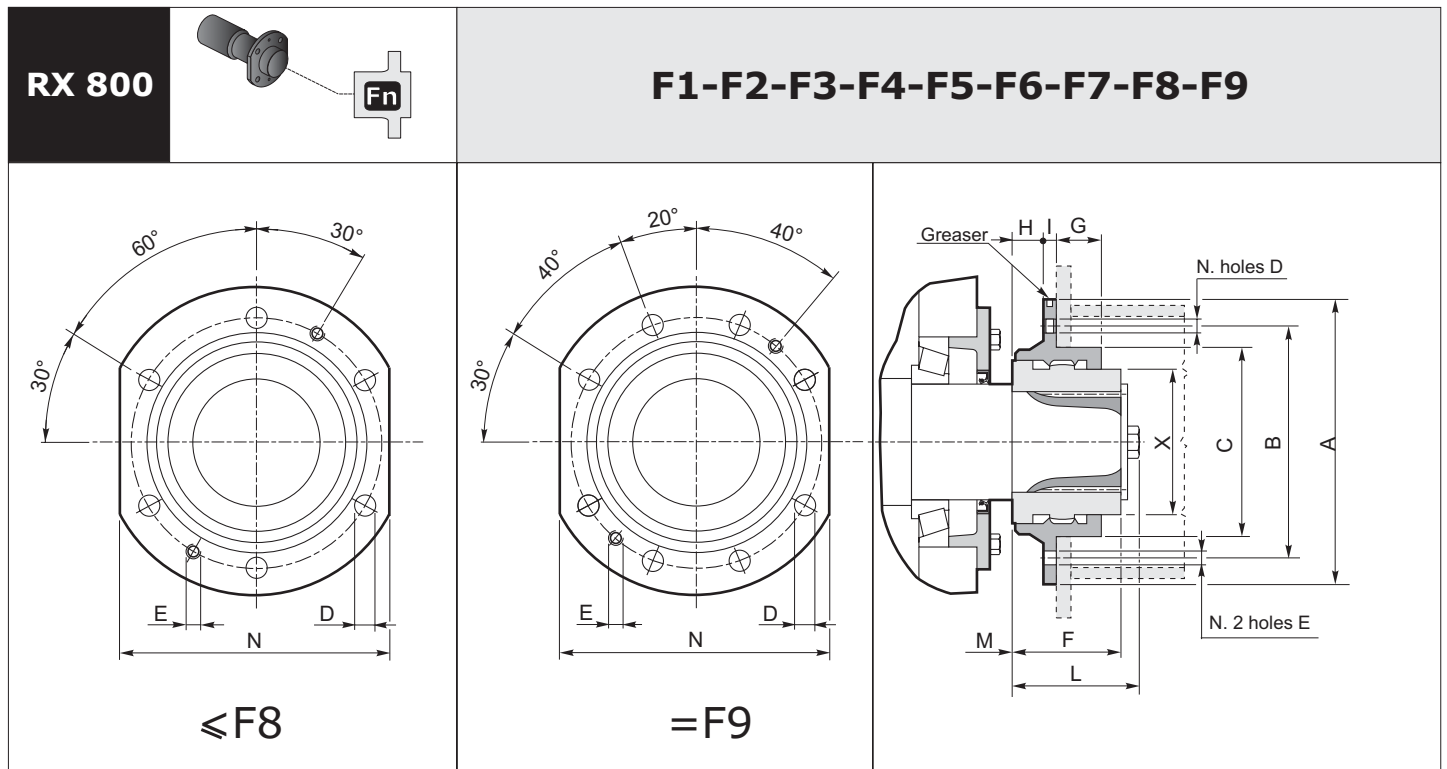

Accoppiamenti riduttori giunti / Gear unit+coupling combinations / Passung von Getrieben-Kupplungen

	F	L	M	Class M	Fr MAX (kN)	Tipo di giunto
						Coupling size
						Kupplungsgröße
808	105	117	151	≤ 7	44	F1
				> 7		F1
810	105	117	170	≤ 7	44	F1
				> 7		F2
812	125	137	192	≤ 7	49	F2
				> 7		F3
814	125	150	216	≤ 7	58	F3
				> 7		F4
816	140	168	242	≤ 7	70	F4
				> 7		F5
818	160	188	273	≤ 6	80	F5
				> 6		F6
820	180	215	302	≤ 6	130	F6
				> 6		F7
822	200	235	340	< 7	160	F7
				≥ 7		F8
824	220	250	383	< 5	180	F8
				≥ 5		F9

Tipo di giunto	Dimensioni generali / General dimensions / Allgemeine Abmessungen										
	Ø A	Ø B	Ø C	N. Fori Holes Anza hl der Bohrungen	Ø D	E	G	H	I	N h9	X
F1	320	280	200	6	18	M16	42.5 - 47	30	15	280	149
F2	340	300	220	6	18	M16	46 - 54	30	15	300	165
F3	380	340	260	6	18	M16	52.5 - 58	30	15	340	195
F4	400	360	280	6	18	M16	59.5 - 65	30	15	360	222
F5	420	380	310	6	18	M16	62.5 - 67	30	15	380	253
F6	450	400	340	6	23	M20	66 - 73	40	20	400	266
F7	510	460	400	6	23	M20	70 - 75	40	20	460	317
F8	550	500	420	6	23	M20	80 - 82	40	20	500	330
F9	580	530	450	8	23	M20	90 - 92	40	20	530	368

1.12.8 - Estremità scanalata albero lento con giunto flangiato a rulli

1.12.8 - Splined output shaft with flanged barrel rollers coupling .

1.12.8 - Abtriebswelle mit Keilende mit geflanschter Tonnenrollenkupplung.

**RX 800**

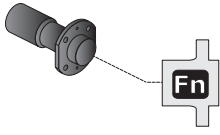

**F101-F102-F103-F104-F105-F106-F107-F108**

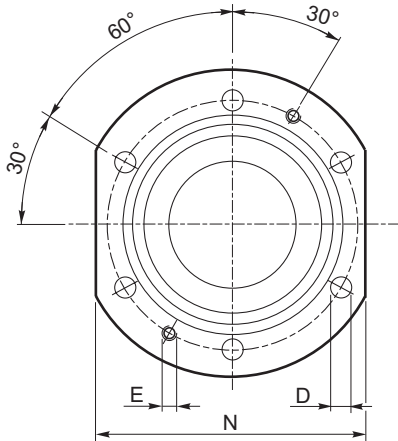

≤F106

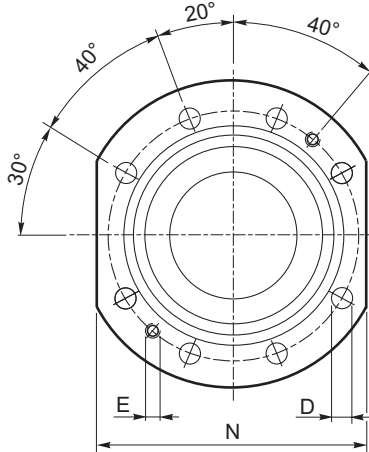

>F106

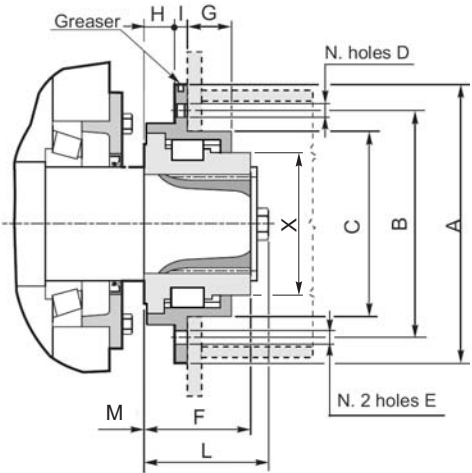







Accoppiamenti riduttori giunti / Gear unit+coupling combinations / Passung von Getrieben-Kupplungen

	F	L	M	Class M	Fr MAX (kN)	Tipo di giunto Coupling size Kupplungsgröße
808	105	117	151	≤ 7	42	F101
				> 7	42	F101
810	105	117	170	≤ 7	42	F101
				> 7	52	F102
812	125	137	192	≤ 7	52	F102
				> 7	63	F103
814	125	150	216	≤ 7	63	F103
				> 7	79.5	F104
816	140	168	242	≤ 7	79.5	F104
				> 7	112.5	F105
818	160	188	273	≤ 6	112.5	F105
				> 6	123	F106
820	180	215	302	≤ 6	123	F106
				> 6	145	F107
822	200	235	340	< 7	145	F107
				≥ 7	202	F108
824	220	250	383	< 5	202	F108
				≥ 5	202	F108

Tipo di giunto Coupling size Kupplungsgröße	Dimensioni generali / General dimensions / Allgemeine Abmessungen										
	∅ A	∅ B	∅ C f8	N. Fori Holes Anzahl der Bohrungen	∅ D	E	G	H	I	N h9	X
F101	380	340	260	6	18	M16	36	30	15	340	149
F102	400	360	280	6	18	M16	36	30	15	360	165
F103	420	380	310	6	18	M16	36	30	15	380	195
F104	450	400	340	6	24	M20	46	40	20	400	222
F105	510	460	400	6	24	M20	46	40	20	460	253
F106	550	500	420	6	24	M20	56	40	20	500	266
F107	580	530	450	8	24	M20	56	40	20	530	317

# U

**ACC. - OPT - ACCESSORI E OPZIONI**  
**ACC. - OPT - ACCESSORIES AND OPTIONS**  
**ACC. - OPT - ZUBEHÖR UND OPTIONEN**

ACC4-R		<b>ACC4</b>	ACC4 - Accessori Vaso Espansione	ACC4 - Accessories Expansion tank	ACC4 - Zubehör Expansionsfaß	<b>U2</b>
ACC5-R		<b>ACC5</b>	ACC5 - Accessori sistema scambiatore	ACC5 - Accessories - Cooling Unit	ACC5 - Zubehör Kühlanlage	<b>U5</b>
		<b>ACC6</b>	ACC6 - Accessori Lubrificazione Forzata BEARING	ACC6 - Accessories - Forced lubrication - BEARING	ACC6 - Zubehör Zwangsschmierung BEARING	<b>U13</b>
		<b>ACC6A</b>	ACC6A - Accessori Lubrificazione Forzata GEAR	ACC6A - Accessories - Forced lubrication - GEAR	ACC6A - Zubehör Zwangsschmierung GEAR	<b>U16</b>
ACC7-R		<b>ACC7A</b>	Accessori idraulici Vibration Sensor	Hydraulic accessories Vibration Sensor	Hydraulikzubehör - Vibration Sensor	<b>U18</b>
		<b>ACC7B</b>	Accessori idraulici Vibration SWITCH	Hydraulic accessories Vibration SWITCH	Hydraulikzubehör - Vibration SWITCH	<b>U19</b>
		<b>ACC7C</b>	Accessori idraulici FILLING	Hydraulic accessories FILLING	Hydraulikzubehör - FILLING	<b>U20</b>
		<b>ACC7D</b>	Accessori idraulici PARTICLE MAGNETIC	Hydraulic accessories PARTICLE MAGNETIC	Hydraulikzubehör PARTICLE MAGNETIC	<b>U21</b>
		<b>ACC7E</b>	Accessori idraulici DRAIN	Hydraulic accessories DRAIN	Hydraulikzubehör - DRAIN	<b>U22</b>
		<b>ACC7F</b>	Accessori idraulici BREATHER	Hydraulic accessories BREATHER	Hydraulikzubehör BREATHER	<b>U23</b>
		<b>ACC7G</b>	Accessori idraulici LEVEL	Hydraulic accessories LEVEL	Hydraulikzubehör - LEVEL	<b>U24</b>
		<b>ACC7H</b>	Accessori idraulici HEATER	Hydraulic accessories HEATER	Hydraulikzubehör - HEATER	<b>U25</b>
		<b>ACC7I1</b>	Accessori idraulici TEMPERATURE SENSOR	Hydraulic accessories TEMPERATURE SENSOR	Hydraulikzubehör TEMPERATURE SENSOR	<b>U26</b>
		<b>ACC7I2</b>	Accessori idraulici TEMPERATURE SWITCH	Hydraulic accessories TEMPERATURE SWITCH	Hydraulikzubehör TEMPERATURE SWITCH	<b>U27</b>
		<b>ACC7I3</b>	Accessori idraulici TEMPERATURE TERMOWELL	Hydraulic accessories TEMPERATURE TERMOWELL	Hydraulikzubehör TEMPERATURE TERMOWELL	<b>U28</b>
		<b>ACC7L</b>	Accessori idraulici FILTER	Hydraulic accessories FILTER	Hydraulikzubehör - FILTER	<b>U29</b>
		<b>ACC7M1</b>	Accessori idraulici PRESSURE SENSOR	Hydraulic accessories PRESSURE SENSOR	Hydraulikzubehör PRESSURE SENSOR	<b>U30</b>
		<b>ACC7M2</b>	Accessori idraulici PRESSURE SWITCH	Hydraulic accessories PRESSURE SWITCH	Hydraulikzubehör PRESSURE SWITCH	<b>U31</b>
		<b>ACC7M3</b>	Accessori idraulici PRESSURE Differential gauge	Hydraulic accessories PRESSURE Differential gauge	Hydraulikzubehör PRESSURE Differential gauge	<b>U32</b>
		<b>ACC7N1</b>	Accessori idraulici FLOW SENSOR	Hydraulic accessories FLOW SENSOR	Hydraulikzubehör - FLOW SENSOR	<b>U33</b>
		<b>ACC7N2</b>	Accessori idraulici FLOW SWITCH	Hydraulic accessories FLOW SWITCH	Hydraulikzubehör - FLOW SWITCH	<b>U34</b>
		<b>ACC7N3</b>	Accessori idraulici FLOW VISUAL	Hydraulic accessories FLOW VISUAL	Hydraulikzubehör - FLOW VISUAL	<b>U35</b>
		<b>ACC7O</b>	Accessori idraulici COOL	Hydraulic accessories COOL	Hydraulikzubehör - COOL	<b>U37</b>
		<b>ACC7P</b>	Accessori idraulici LEVEL-BREATHER	Hydraulic accessories LEVEL-BREATHER	Hydraulikzubehör LEVEL-BREATHER	<b>U38</b>
<b>ACC7Z</b>	Accessori idraulici GENERIC	Hydraulic accessories GENERIC	Hydraulikzubehör GENERIC	<b>U39</b>		
ACC8-R		<b>ACC8</b>	ACC8 - Accessori - Tipo Tenute	ACC8 - Accessories - Seal Type	ACC8 - Zubehör - Typ von Dichtung	<b>U41</b>
		<b>ACC8A</b>	Accessori - Static Seal COMPOUND	Accessories - Static Seal COMPOUND	Zubehör - Static Seal COMPOUND	<b>U45</b>
OPT		<b>OPT</b>	OPT - Opzioni Materiale degli anelli di tenuta	OPT - Options - Materials of Seals	OPT - Optionen Dichtungsstoffe	<b>U46</b>
ACC9-R		<b>ACC9A</b>	Accessori generali - Coperchio di ispezione	Accessories custom - Inspection Cover	Zubehör custom - Inspektionsdeckel	<b>U49</b>
		<b>ACC9B</b>	Accessori generali - Flangia freno	Accessories custom - Brake Flange	Zubehör custom - Bremsflansch	<b>U49</b>
		<b>ACC9C</b>	Accessori generali - Base motore	Accessories custom - Motor Mount	Zubehör custom - Motorbasis	<b>U51</b>
ESTREMITÀ SUPPLEMENTARI ADDITIONAL SHAFT EXTENSIONS ZUSÄTZLICHE WELLENENDE						<b>U53</b>





<b>ACC4</b>	<b>ACC4 - Accessori - Vaso Espansione</b>	<b>ACC4 - Accessories - Exspansion tank</b>	<b>ACC4 - Zubehör - Expansionsfäß</b>
-------------	---	---	---

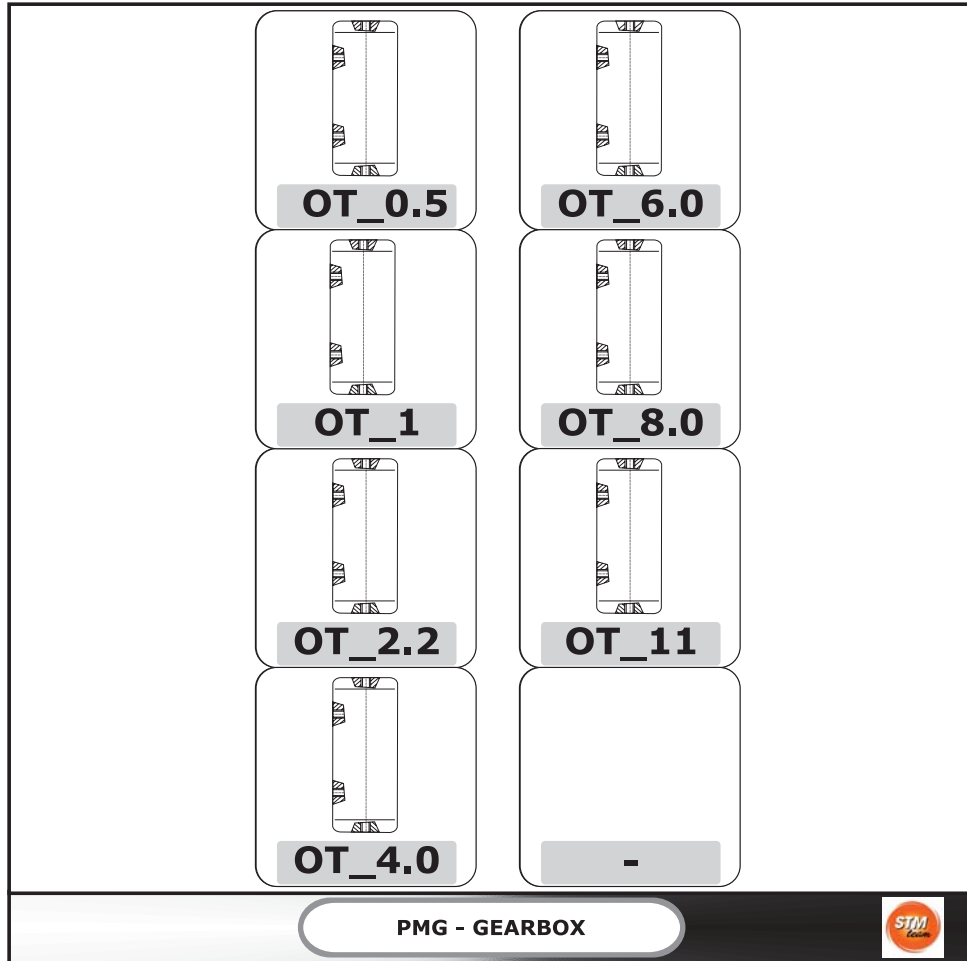

E' possibile richiedere diverse tipologie di dispositivi per consentire la dilatazione termica dell'olio.

Possono essere forniti i seguenti accessori e dispositivi:

*It is possible to request various types of devices to allow the oil thermal expansion.*

*Some devices can optionally be provided:*

Es können verschiedene Vorrichtungstypen angefordert werden, um die Wärmeausdehnung des Öls zu ermöglichen.

Folgende Zubehörteile und Vorrichtungen können geliefert werden:

Code Designation	Code ORDER	I	GB	DE
OT_0.5		= Vaso espansione - 0.5 litri	= Exspansion tank 0.5 - l	= Expansionsfäß - 0.5 - l
OT_1		= Vaso espansione - 1.0 litri	= Exspansion tank 1.0 - l	= Expansionsfäß - 1.0 - l
OT_2.2		= Vaso espansione - 2.2 litri	= Exspansion tank 2.2 - l	= Expansionsfäß - 2.2 - l
OT_4.0		= Vaso espansione - 4.0 litri	= Exspansion tank 4.0 - l	= Expansionsfäß - 4.0 - l
OT_6.0		= Vaso espansione - 6.0 litri	= Exspansion tank 6.0 - l	= Expansionsfäß - 6.0 - l
OT_8.0		= Vaso espansione - 8.0 litri	= Exspansion tank 8.0 - l	= Expansionsfäß - 8.0 - l
OT_11		= Vaso espansione - 11.0 litri	= Exspansion tank 11.0 - l	= Expansionsfäß - 11.0 - l



Scelta Grandezza OT  
OT selection  
OT Auswahl

Differenza temperatura tra temperatura funzionamento riduttore e temperatura ambiente - *Temperature difference in between the operating temperature and the ambient temperature*  
-Temperaturschwankungen zwischen der Betriebstemperatur und der Raumtemperatur

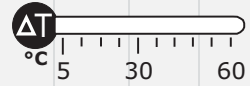

		5	10	15	20	25	30	35	40	45	50	55	60
1.0													
2.0													
3.0													
4.0													
5.0													
6.0													
7.0													
8.0													
9.0													
10.0													
11.0													
12.0													
13.0													
14.0													
15.0													
16.0													
17.0													
18.0													
19.0													
20.0													
21.0													
22.0													
23.0													
24.0													
25.0													
26.0													
27.0													
28.0													
29.0													
30.0													
31.0													
32.0													
33.0													
34.0													
35.0													
36.0													
37.0													
38.0													
39.0													
40.0													
41.0													
42.0													
45.0													
50.0													
60.0													
70.0													
80.0													
90.0													
100.0													
110.0													
120.0													
130.0													
140.0													
150.0													
160.0													
170.0													
180.0													
190.0													

05

1

2.2

4.0

6.0

8.0

11



Litri Riduttore  
Gearbox liters  
Liter der  
Getriebe







**OT 05**

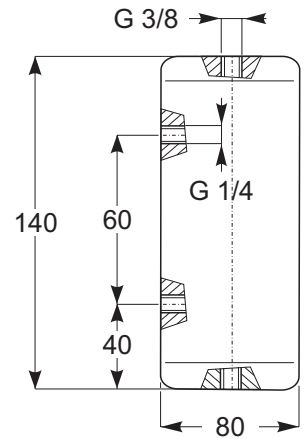

**OT 1**

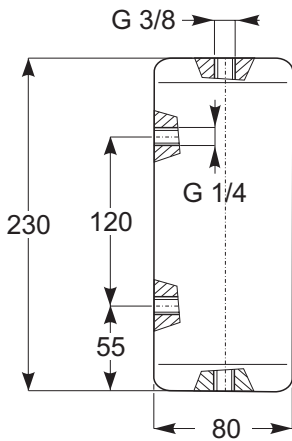

**OT 2.2**

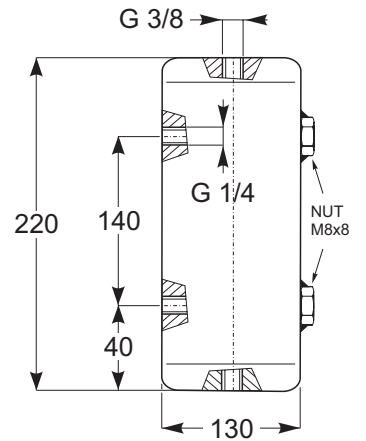

**OT 4.0**

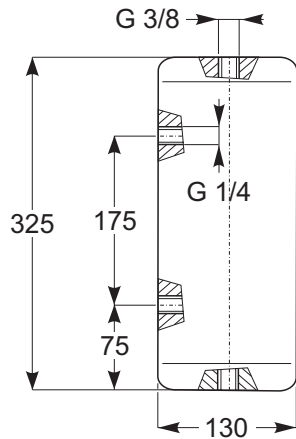

**OT 6.0**

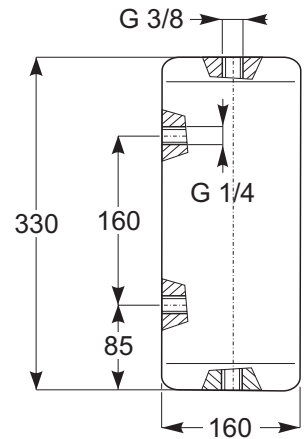

**OT 8.0**

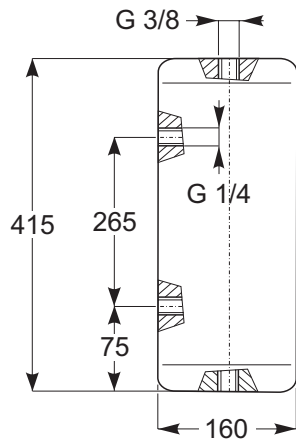

**OT 11**

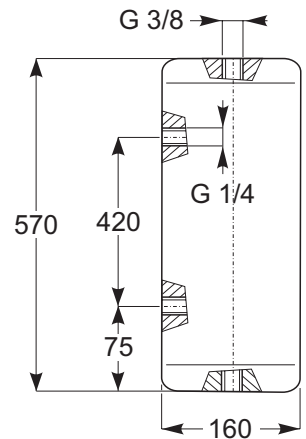

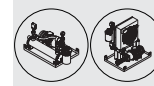

<b>ACC5</b>	<b>ACC5 - Accessori - sistema con scambiatore</b>	<b>ACC5 - Accessories - Cooling Unit</b>	<b>ACC5 - Zubehör - Kühlanlage</b>
-------------	---	--	------------------------------------

-	<b>RFW1</b>	<b>RFW4</b>	<b>RFA1</b>	<b>RFA4</b>
	<b>RFW2</b>	<b>RFW5</b>	<b>RFA2</b>	<b>RFA5</b>
		da fare		
	<b>RFW3</b>	<b>RFW6</b>	<b>RFA3-A</b>	<b>RFA6</b>
		da fare		
		<b>RFW7</b>	<b>RFA3-B</b>	<b>RFA7</b>
		da fare		
		<b>RFW8</b>		

**PMG - GEARBOX**

E' possibile richiedere diverse tipologie di dispositivi per consentire il raffreddamento dell'olio, utilizzando degli scambiatori di calore esterni al riduttore.

*It is possible to request various types of devices to allow the cooling of the oil, by using heat exchangers outside the gearbox.*

Es können verschiedene Vorrichtungstypen angefordert werden, um die Abkühlung des Öls unter Einsatz von extern am Getriebe angeordneten Wärmetauschern zu ermöglichen.

Possono essere forniti i seguenti accessori e dispositivi:

*Some devices can optionally be provided:*

Folgende Zubehörteile und Vorrichtungen können geliefert werden:

Code Designation	Code ORDER	I	GB	DE
RFW1		= RFW1 - sistema con scambiatore acqua-olio	= RFW1 - water/oil exchanger	= RFW1 - System mit Wasser-/Ölaustauscher
RFW2		= RFW2 - sistema con scambiatore acqua-olio	= RFW2 - water/oil exchanger	= RFW2 - System mit Wasser-/Ölaustauscher
RFW3		= RFW3 - sistema con scambiatore acqua-olio	= RFW3 - water/oil exchanger	= RFW3 - System mit Wasser-/Ölaustauscher
RFW4		= RFW4 - sistema con scambiatore acqua-olio	= RFW4 - water/oil exchanger	= RFW4 - System mit Wasser-/Ölaustauscher
RFW5		= RFW5 - sistema con scambiatore acqua-olio	= RFW5 - water/oil exchanger	= RFW5 - System mit Wasser-/Ölaustauscher
RFW6		= RFW6 - sistema con scambiatore acqua-olio	= RFW6 - water/oil exchanger	= RFW6 - System mit Wasser-/Ölaustauscher
RFW7		= RFW7 - sistema con scambiatore acqua-olio	= RFW7 - water/oil exchanger	= RFW7 - System mit Wasser-/Ölaustauscher
RFW8		= RFW8 - sistema con scambiatore acqua-olio	= RFW8 - water/oil exchanger	= RFW8 - System mit Wasser-/Ölaustauscher
RFA1		= RFA1 - sistema con scambiatore aria-olio	= RFA1 - air/oil exchanger	= RFA1 - System mit Luft-/Ölaustauscher
RFA2		= RFA2 - sistema con scambiatore aria-olio	= RFA2 - air/oil exchanger	= RFA2 - System mit Luft-/Ölaustauscher
RFA3-A		= RFA3-A - sistema con scambiatore aria-olio	= RFA3-A - air/oil exchanger	= RFA3-A - System mit Luft-/Ölaustauscher
RFA3-B		= RFA3-B - sistema con scambiatore aria-olio	= RFA3-B - air/oil exchanger	= RFA3-B - System mit Luft-/Ölaustauscher
RFA4		= RFA4 - sistema con scambiatore aria-olio	= RFA4 - air/oil exchanger	= RFA4 - System mit Luft-/Ölaustauscher
RFA5		= RFA5 - sistema con scambiatore aria-olio	= RFA5 - air/oil exchanger	= RFA5 - System mit Luft-/Ölaustauscher
RFA6		= RFA6 - sistema con scambiatore aria-olio	= RFA6 - air/oil exchanger	= RFA6 - System mit Luft-/Ölaustauscher
RFA7		= RFA7 - sistema con scambiatore aria-olio	= RFA7 - air/oil exchanger	= RFA7 - System mit Luft-/Ölaustauscher



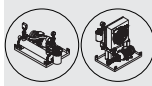

## 1.0 - Gruppo di raffreddamento

Il raffreddamento con scambiatore di calore può essere suddiviso in due tipologie principali: con scambiatore acqua-olio e con scambiatore aria olio, ogni categoria è divisa in più grandezze, con potenze di scambio diversificate. Ogni gruppo di raffreddamento è fornito separatamente al riduttore; i tubi di collegamento tra riduttore ed impianto non sono a carico GSM.

## 1.0 - Cooling Unit

*Water/oil and air/oil heat exchangers are available in a range of different sizes and heat exchange capacities. Each cooling unit is supplied separate from the gear unit; pipes or hoses for connection to plant must be provided by GSM.*

## 1.0 - Kühlanlage

Die Kühlung mittels Wärmeaustauschers lässt sich in zwei Haupttypologien unterteilen: mit Wasser-/Ölaustauscher und Luft-/Ölaustauscher. Jede Kategorie ist in mehrere Größen unterteilt, die unterschiedliche Austauschleistungen aufweisen. Jedes Kühlaggregat wird in vom Getriebe getrennter Form geliefert; die Verbindungsleitungen zwischen Getriebe und Anlage gehen nicht zu Lasten der GSM.

### RFW

#### 1.1 - RFW - sistema con scambiatore acqua-olio

##### 1.1.1 Generalità

Sempre più spesso è indispensabile raffreddare l'olio con acqua se si ha sufficiente disponibilità d'acqua pulita.

In alcuni casi, poi, non è possibile collegare lo scambiatore olio-acqua direttamente allo scarico a causa della presenza nel circuito di colpi d'ariete, e si è costretti a realizzare un circuito separato con una pompa autonoma di circolazione, tubazioni, pressostato ed impianto elettrico.

Per questi casi, ora sempre più frequenti, GSM S.p.A. ha provveduto inserendo nella propria produzione i gruppi autonomi di raffreddamento serie RFW, che risolvono nel migliore dei modi il compito di raffreddare l'olio, indipendentemente dall'impianto idraulico primario.

L'unità è stata studiata per raffreddare l'olio e consiste in un scambiatore a fascio tubiero che, ponendo a contatto l'olio messo in circolazione dalla motopompa con la serpentina dell'acqua, asporta il calore ceduto.

Tutte le parti metalliche sono protette da verniciatura a polvere per garantire una lunga durata agli agenti atmosferici.

Nell'esecuzione standard l'unità è fornita con tutti i particolari assemblati su un telaio.

##### 1.1.2 Stato fornitura e caratteristiche tecniche

Le unità di raffreddamento serie RFW standard sono composte da:

- 1 - Uno scambiatore di calore acqua-olio;
- 2 - Una motopompa composta da un motore a 4 poli in forma B3/B5, alimentazione standard trifase 230-400V 50 hz e da una pompa ad ingranaggi o a vite;
- 3 - Manometro 0-16 bar montato fra pompa e scambiatore di calore;
- 4 - Termometro analogico 0-120 °C, montato in uscita dallo scambiatore;
- 5 - Pressostato di minima con contatti in scambio, montato fra pompa e scambiatore di calore;
- 6 - Filtro, in mandata al serbatoio, per la pulizia dell'olio scaricato;
- 7 - Indicatore elettrico di intasamento

A – Aspirazione della pompa;  
M – Mandata della pompa.

#### 1.1 - RFW - water/oil exchanger

##### 1.1.1 General features

*If sufficient clean water is available, it is often required to cool down oil with water. Moreover, in some cases it is not possible to connect oil-water exchanger directly to the drainage due to water hammers in the circuit, and user is thus forced to set up a separated circuit with independent circulation pump, tubing, pressure switch and electric system. These cases are very frequent nowadays, this is why GSM S.p.A. has added to its product range the independent cooling units of the RFW series, that best carry out the task of cooling down oil in an independent way with respect to the main hydraulic system. This unit is designed for cooling down oil and consists in a tube bundle heat exchanger that sinks heat released from oil (circulated by motor pump) thanks to contact with water coil.*

*All metal parts are powder-coated to ensure long lasting protection against weather conditions. In the standard version, the unit features all parts assembled to a frame.*

##### 1.1.2 Supply scope and specifications

*Standard cooling units of the RFW series consist of:*

- 1 - A water-oil heat exchanger;
- 2 - A motor pump made of a 4-pole motor rated B3/B5, standard three-phase 230-400V 50 Hz power and a gear or screw pump;
- 3 - 0-16 bar Pressure gauge mounted between pump and heat exchanger;
- 4 - 0-120 °C Analogue thermometer mounted at exchanger outlet;
- 5 - Minimum pressure switch with switch contacts, mounted between pump and heat exchanger;
- 6 - Filter, at tank inlet, for cleaning drained oil;
- 7 - Electrical clogging indicator

A – Pump inlet;  
M – Pump outlet.

#### 1.1 - RFW - System mit Wasser-/Ölaustauscher

##### 1.1.1 Allgemeine Informationen

Immer häufiger ist es unerlässlich das Öl mit Wasser zu kühlen, wenn ausreichend Wasser verfügbar ist. In einigen Fällen ist ein direkter Anschluss des Öl-Wasser-Wärmeaustauschers an den Anschluss aufgrund von Widerstoßen im System nicht möglich und man ist dazu gezwungen einen separaten Kreislauf mit einer eigenständigen Umlaufpumpe, Leitungen, Druckwächter und elektrischer Anlage zu realisieren. Für diese immer häufiger auftretenden Fälle hat die GSM S.p.A.

autonome Kühlaggregate der Serie RFW in ihr Programm aufgenommen, die die Aufgabe der Ölkühlung, von der hydraulischen Hauptanlage unabhängig, in der besten Art und Weise erfüllen. Diese Einheit wurde für das Kühlen des Öls entwickelt und stellt sich in einem Wärmeaustauscher mit Rohrbündel dar, der die abgestrahlte Wärme ableitet, indem er das von der Motorpumpe in den Umlauf gebrachte Öl mit der Wasserrohrschlange in Kontakt bringt. Alle Metallteile sind durch eine Pulverlack-lackierung geschützt, die einen lang anhaltenden Schutz gegen Umweltbelastungen gewährt.

In der Standardversion wird die Einheit bereits mit allen am Rahmen montierten Teilen geliefert.

##### 1.1.2 Lieferzustand und technische Eigenschaften

Die Kühleinheiten der Serie RFW Standard setzen sich aus folgenden Komponenten zusammen:

- 1 - einen Wasser-Öl-Wärmeaustauscher;
- 2 - einer Motorpumpe bestehend aus einem 4-poligem Motor in Bauform B3/B5, Standard-Drehstromversorgung 230-400V 50 Hz und einer Zahnrad- oder Schneckenpumpe;
- 3 - Manometer 0-16 bar, zwischen Pumpe und Wärmeaustauscher montiert;
- 4 - analoges Thermometer 0-120 °C, am Ausgang des Wärmeaustauschers montiert;
- 5 - Mindestdruckwächter mit Wechselkontakten, zwischen Pumpe Wärmeaustauscher montiert;
- 6 - Filter, im Zulauf zum Behälter, für die Reinigung des abgelassenen Öls
- 7 - elektrische Verstopfungsanzeige.

A – Ansaugung der Pumpe;  
M – Zulauf der Pumpe.

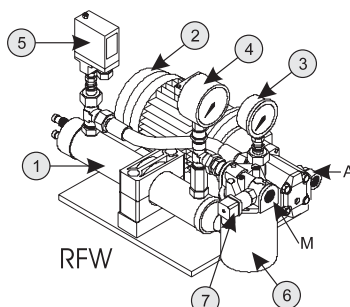

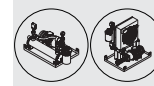

**1.0 - Gruppo di raffreddamento**

**1.0 - Cooling Unit**

**1.0 - Kühlanlage**

**1.1.3 Dimensionamento e Caratteristiche Funzionali**

Per la scelta del gruppo di raffreddamento si rimanda alla Sezione A-B-C-D-E-F-G.

**1.1.3 Sizes and Functional Features**  
Please refer to Section A-B-C-D-E-F-G for indications on how to choose the suitable cooling unit.

**1.1.3 Bemaßung und Funktionseigenschaften**  
Für die Wahl des richtigen Kühlaggregats verweisen wir auf die Sektion A-B-C-D-E-F-G.

**CARATTERISTICHE TECNICHE**

Nella Tabella sottostante riportiamo le caratteristiche tecniche

**SPECIFICATIONS**

The specifications are given in the table below

**TECHNISCHE EIGENSCHAFTEN**

In der nachstehenden Tabelle werden die technischen Eigenschaften angegeben.

Grandezza Size Baugröße Size	Peso Weight Gewicht [Kg]	Volume Olio Oil volume Ölvolumen [dm <sup>3</sup> ]	Motopompa Motor Pump Motorpumpe				Scambiatore Exchanger Wärmeaustauscher				Campo Applicazione Application Einsatzbereich	
			[*1]	[*2]	[*3]	[*4]	Connessione Olio Oil connection Ölanschluss		[*7]	[*8]	Raffreddamento Cooling Kühlung	Lubrificazione Forzata Forced Lubrication Zwangsschmierung
							[*5]	[*6]				
1	13	0,4	Ingranaggi Gear-type Zahnräder	0.37	6	230/400 50	G 1/2"	G 3/4"	G 1/2"	8-30	SI YES JA	SI YES JA
2	15	0,6		0.37	6					10-30		
3	18	1,2		0.55	16					16-30		
4	44	3,0	Vite Screw-type Schnecke	1.5	30		G 3/4"	G 1" 1/4	G 1"	40-110		
5	70	4,5		2.2	80		G 1" 1/4	G 1" 1/2	G 1"	80-110		
6	On request			7.50	135.0		G 2"	On request	G 1"	90-110		
7	On request			7.50	200.0		G 2"	On request	G 1"	180-220		
8	On request			7.50	200.0		G 2"	On request	G 1"	270-330		

Legenda/Legend/Legende  
 [\*1] Tipo Pompa/Pump type/Pumpentyp  
 [\*2] Potenza /Power/Leistung [kW]  
 [\*3] Portata /Flow rate/Durchsatz [dm<sup>3</sup> / min]  
 [\*4] Alimentazione /Power supply/Versorgung [V / Hz]  
 [\*5] Aspirazione /Inlet/Ansaugung  
 [\*6] Mandata /Outlet/Zulauf  
 [\*7] Connessione Acqua /Water connection/Wasseranschluss  
 [\*8] Portata Acqua /Water flow rate/Wasserdurchsatz [l / min]

**1.1.4 Dimensioni**

**1.1.4 Dimensions**

**1.1.4 Maße**

**RFW 1**

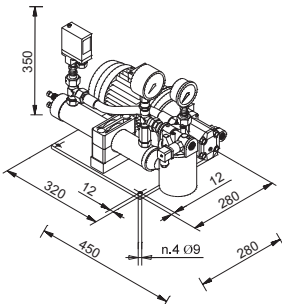

**RFW 2**

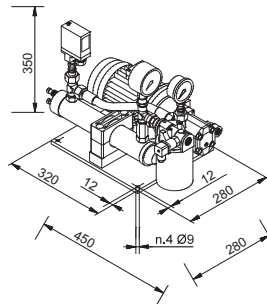

**RFW 3**

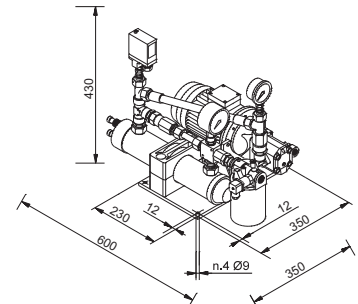

**RFW 4**

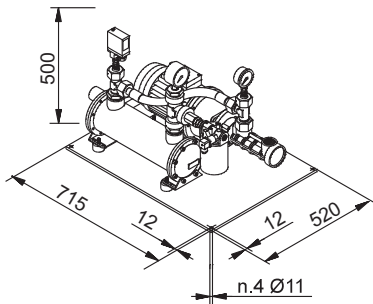

**RFW 5**

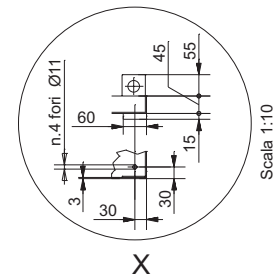
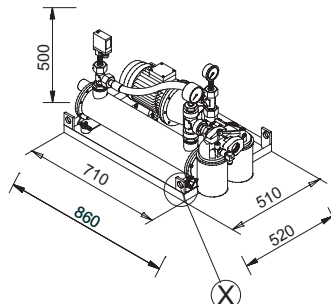

**RFW 6**

On request

**RFW 7**

On request

**RFW 8**

On request

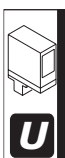



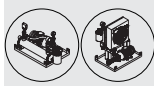

## 1.0 - Gruppo di raffreddamento

RFA

### 1.2 - RFA - sistema con scambiatore aria-olio

#### 1.2.1 Generalità

Sempre più spesso è indispensabile raffreddare l'olio con l'aria, poiché non si ha sufficiente disponibilità d'acqua.

In alcuni casi poi, non è possibile collegare lo scambiatore aria-olio direttamente allo scarico a causa della presenza nel circuito di colpi d'ariete, e si è costretti a realizzare un circuito separato con una pompa autonoma di circolazione, tubazioni, termostato ed impianto elettrico.

La GSM S.p.A. ha provveduto inserendo nella propria produzione i gruppi autonomi di raffreddamento serie RFA, che risolvono nel migliore dei modi il compito di raffreddare l'olio, indipendentemente dall'impianto idraulico primario.

Un problema che oggi si fa sempre più pressante è il risparmio nei consumi d'energia.

Utilizzando per il raffreddamento acqua a perdere si spreca calore che l'olio ha ceduto all'acqua.

Utilizzando invece l'aria emessa dai gruppi RFA è possibile recuperare il calore ceduto dall'olio, scaldando l'ambiente in cui essi sono installati.

Oggi, il consumo dell'acqua per usi industriali ha costi sempre molto elevati ed in molti casi le aziende devono munirsi d'impianti refrigeranti in circuito chiuso dell'acqua di raffreddamento e nella maggior parte dei casi esse sono macchine frigorifere.

Il consumo d'energia di questi impianti è ingente ed è pari a circa il 30% della potenza da disperdere.

Con i gruppi autonomi serie RFA questo consumo scende al 6%, con un considerevole risparmio d'energia elettrica e quindi di costo d'esercizio, senza contare il costo iniziale notevolmente inferiore.

L'unità è stata studiata per raffreddare l'olio e consiste in un radiatore che è attraversato dal flusso d'aria generato da un ventilatore, il quale lambendo le alettature in alluminio della massa radiante asporta il calore ceduto dall'olio, che circola nel radiatore dal basso verso l'alto grazie alla pompa a vite di ricircolo.

Il controllo del corretto funzionamento della macchina è regolato dai termostati che ne ottimizzano il funzionamento nel caso d'eventuali sbalzi di temperatura.

Tutte le parti metalliche sono protette da verniciatura a polvere per garantire una lunga durata agli agenti atmosferici.

Nell'esecuzione standard l'unità è fornita con tutti i particolari assemblati su un telaio palettizzabile

#### 1.2.2 Stato fornitura e caratteristiche tecniche

Le unità di raffreddamento serie RFA standard sono composte da:

1. Uno scambiatore di calore aria-olio;
2. Una motopompa composta da un motore a 4 poli per le grandezze RFA1, RFA2, RFA3 e 2 poli per le grandezze RFA4, RFA5 in forma B3/B5, alimentazione standard trifase 230-400V 50 Hz.  
Per i gruppi facenti parte dello schema A (RFA1 – RFA2 – RFA3) il motore della motopompa è il medesimo del motoventilatore.
3. SCHEMA A: Manometro 0-12 bar con funzione aggiuntiva di indicatore visivo di intasamento;  
SCHEMA B: Manometro 0-16 bar montato fra pompa e scambiatore di calore ;
4. Termometro analogico 0-120 °C, montato in uscita dallo scambiatore.
5. Pressostato di minima con contatti in scambio, montato fra pompa e scambiatore di calore.
6. Filtro, in mandata al serbatoio, per la pulizia dell'olio scaricato.

## 1.0 - Cooling Unit

### 1.2 - RFA - air/oil exchanger

#### 1.2.1 General features

*When no sufficient water is available, it is more and more often indispensable to cool down oil with air.*

*Moreover, in some cases it is not possible to connect air-oil exchanger directly to the drainage due to water hammers in the circuit, and user is thus forced to set up a separated circuit with independent circulation pump, tubing, thermostat and electric system.*

*To meet the needs of these instances, GSM S.p.A. has added to its product range the independent cooling units of the RFA series, that best carry out the task of cooling down oil in an independent way with respect to the main hydraulic system.*

*Nowadays, energy-saving is a major issue and using water for cooling without recycling it means wasting the heat released by oil to water. While, using air issued by the RFA units, it is possible to recover the heat released by oil and use it to heat the room where they are installed. Water for industrial use is quite expensive and in many cases businesses need to set up closed-loop water cooling systems and most of the time they are refrigerating machines. Power consumption of these systems is huge, equal to about 30% of power to be wasted. With RFA series independent units this consumption is reduced to 6%, with a considerable saving in power and thus in running costs and with a remarkably lower starting cost. The unit is designed to cool down oil and consists in a radiator that is in the air flow generated by a fan; while oil is circulated in the radiator from bottom up by the recirculation screw pump, oil heat is dissipated by the air flow lapping on the aluminium fins of the radiator core. Machine correct operation is controlled by thermostats optimising its operation in case of any sudden change of temperature.*

*All metal parts are powder-coated to ensure long lasting protection against weather conditions.*

*In the standard version, the unit features all parts assembled to a frame which can be placed on a pallet.*

#### 1.2.2 Supply scope and specifications

*Standard cooling units of the RFA series consist of:*

1. An air-oil heat exchanger;
2. A motor pump made of a 4-pole motor for sizes RFA1, RFA2, RFA3 and 2-pole motor for sizes RFA4, RFA5 rated B3/B5, standard three-phase 230-400V 50 Hz power. For units belonging to diagram A (RFA1 – RFA2 – RFA3) motor pump motor is the same as motor fan one.
3. DIAGRAM A: 0-12 bar Pressure gauge mounted between pump and heat exchanger; with added function of oil flow blocking display  
DIAGRAM B: 0-16 bar Pressure gauge mounted between pump and heat exchanger;
4. 0-120 °C Analogous thermometer mounted at exchanger outlet.
5. Minimum pressure switch with switch contacts, mounted between pump and heat exchanger.
6. Filter, at tank inlet, for cleaning drained oil.

## 1.0 - Kühlanlage

### 1.1 - RFA - System mit Luft-/Ölaustauscher

#### 1.2.1 Allgemeine

Informationen immer häufiger ist es unerlässlich das Öl mit Luft zu kühlen, da man nicht ausreichend Wasser verfügbar hat. In einigen Fällen ist ein direkter Anschluss des Luft-Wasser- Wärmeaustauschers an den Anschluss aufgrund von Widerständen im System nicht möglich und man ist dazu gezwungen einen separaten Kreislauf mit einer eigenständigen Umlaufpumpe, Leitungen, Thermostat und elektrischer Anlage zu realisieren. Die GSM S.p.A. hat autonome Kühlaggregate der Serie RFA in ihr Programm aufgenommen, die die Aufgabe der Ölkühlung, von der hydraulischen Hauptanlage unabhängig, in der besten Art und Weise erfüllen. Die Energieeinsparung ist heute ein Problem, dem immer mehr Bedeutung zukommt. Wird für die Kühlung nicht wiederverwendbares Wasser verwendet, geht die Wärme verloren, die das Öl ans Wasser abgegeben hat. Wird dagegen von den RFA-Aggregaten zugeführte Luft verwendet, kann die an der Öl abgegebene Wärme zurückgewonnen und für die Heizung des Raums verwendet werden, in dem sie installiert sind. Der Wasserkonsum für den industriellen Einsatz ist heute mit immer stärker steigenden Kosten verbunden und in vielen Fällen müssen sich die Firmen mit Kühlsystemen im geschlossenen Kühlwasserkreislauf ausrüsten, dabei handelt es sich in den meisten Fällen um Kühlmaschinen. Der Energieverbrauch dieser Anlagen ist beachtlich und entspricht ungefähr 30% der verbrauchbaren Leistung. Mit den autonomen Aggregaten der Serie RFA sinkt dieser Konsum auf 6% ab, eine erhebliche Einsparung bei Strom also bei Betriebskosten, ohne dabei die erheblich geringeren Anschaffungskosten zu berücksichtigen. Die Einheit wurde für die Kühlung von Öl entwickelt und besteht aus einem Kühler, der von einem durch einen Ventilator erzeugten Luftstrom durchquert wird, der die Aluminiumrippen der Kühlmasse "umspült" und die vom Öl abgegebene Wärme abnimmt. Das Öl zirkuliert dank der Schneckenumlaufpumpe im Kühler von unten nach oben. Die Steuerung des korrekten Maschinenbetriebs wird von den Thermostaten geregelt, die den Betrieb im Fall von eventuellen Temperaturschwankungen optimiert. Alle Metallteile sind durch eine Pulver- lacklackierung geschützt, die einen lang anhaltenden Schutz gegen Umweltbelastungen gewährleistet. In der Standardversion wird die Einheit bereits mit allen an einem palettierbaren Rahmen montierten Teilen geliefert.

#### 1.2.2 Lieferzustand und technische Eigenschaften

Die Kühleinheiten der Serie RFA Standard setzen sich wie folgt zusammen:

1. Ein Luft-Öl-Wärmeaustauscher;
2. Eine Motorpumpe bestehend aus einem 4-poligem Motor für die Baugrößen RFA1, RFA2, RFA3 oder 2-poligem Motor für die Baugrößen RFA4, RFA5 in Bauform B3/B5, Standard-Drehstromversorgung 230-400V 50 Hz. Bei den Aggregaten, die zum Schema A (RFA1 – RFA2 – RFA3) gehören werden Motorpumpe und Ventilator vom selben Motor betrieben.
3. SCHEMA A: Manometer 0-12 bar, zwischen Pumpe und Wärmeaustauscher montiert; mit Zusatzanzeige für blockierten Ölfloss  
SCHEMA B: Manometer 0-16 bar, zwischen Pumpe und Wärmeaustauscher montiert;
4. Analoges Thermometer 0-120 °C, am Ausgang des Wärmeaustauschers montiert;
5. Mindestdruckwächter mit Umschaltkontakten, zwischen Pumpe und Wärmeaustauscher montiert;
6. Filter, im Zulauf zum Behälter, für die Reinigung des abgelassenen Öls;



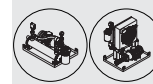

**1.0 - Gruppo di raffreddamento**

**1.0 - Cooling Unit**

**1.0 - Kühlanlage**

- 7. Indicatore elettrico di intasamento del filtro olio.
- 8. Scatola Morsettiera;
- 9. Termostato di regolazione;

- 7. *Electrical clogging indicator of oil filter.*
- 8. *Terminal board box;*
- 9. *Adjustment thermostat;*

- 7. Elektrische Verstopfungsanzeige des Ölfilters
- 8. Klemmenkasten;
- 9. Regelthermostat;

A – Aspirazione della pompa;  
M – Mandata della pompa.

A – *Pump inlet;*  
M – *Pump outlet.*

A – Ansaugung der Pumpe;  
M – Zulauf der Pumpe.

**NOTE SPECIFICHE - SCHEMA A :**  
Il gruppo RFA3 è fornito con sonda di temperatura e termostato.

**SPECIFIC NOTES - DIAGRAM A:**  
*RFA3 unit is supplied together with temperature probe and thermostat.*

**SPEZIFISCHE HINWEISE - SCHEMA A :**  
Das Aggregat RFA3 wird mit einer Temperatursonde und einem Thermostat geliefert.

**ATTENZIONE:**  
Il gruppo RFA3 è fornito secondo lo schema A quando l'applicazione necessita di solo raffreddamento altrimenti è fornito RFA3 secondo lo schema B.

**NOTICE:**  
*RFA3 unit is supplied as per diagram A when the application only needs cooling, while in other cases RFA3 is supplied as per diagram B.*

**ACHTUNG:**  
Das Aggregat RFA3 wird dem Schema A gemäß geliefert, wenn die Applikation nur einer Kühlung bedarf, andernfalls wird das RFA3 dem Schema B entsprechend geliefert.

**RFA**

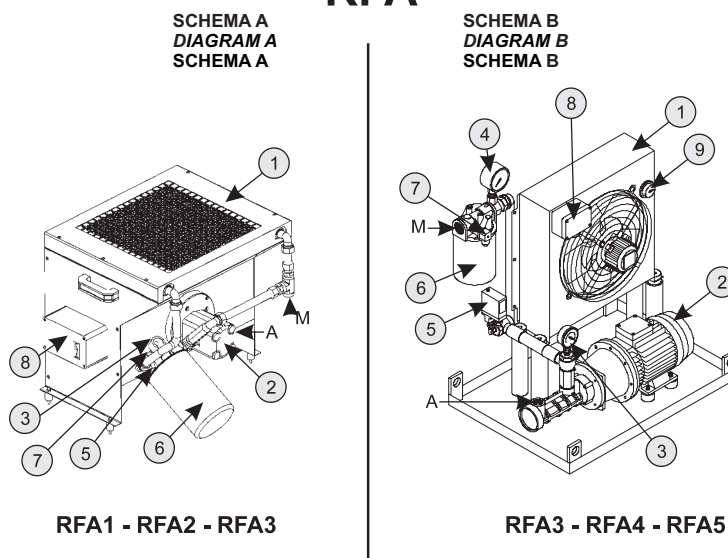

**1.2.3 Dimensionamento e Caratteristiche Funzionali**

Per la scelta del gruppo di raffreddamento si rimanda alla Sezione A-B-C-D-E-F-G.

**1.2.3 Sizes and Functional Features**

Please refer to Section A-B-C-D-E-F-G for indications on how to choose the suitable cooling unit.

**1.2.3 Bemaßung und Funktionseigenschaften**

Für die Wahl des richtigen Kühlaggregats verweisen wir auf die Sektion A-B-C-D-E-F-G.

**CARATTERISTICHE TECNICHE**

Nella Tabella sottostante riportiamo le caratteristiche tecniche

**SPECIFICATIONS**

The specifications are given in the table below

**TECHNISCHE EIGENSCHAFTEN**

In der nachstehenden Tabelle werden die technischen Eigenschaften angegeben.

Schema Diagram Schema	Grandezza Size Baugröße	Peso Weight Gewicht [Kg]	Volume Olio Oil volume Ölvolumen [dm <sup>3</sup> ]	Motopompa Motor Pump Motorpumpe				Scambiatore Exchanger Wärmeaustauscher					Campo Applicazione Application Einsatzbereich		
				[*1]	[*2]	[*3]	[*4]	Connessione Olio Oil connection Ölschluss		[*7]	[*8]	[*9]	Raffreddamento Cooling Kühlung	Lubrificazione Forzata Forced lubrication Zwangsschmier.	
A	1	20	3.0	Ingranaggi Gear-type Zahnräder	0.55	6	400 / 50 Trifase Three-phase dreiphasig	G 1/2"	G 1/2"	0.55	600	64	SI YES JA	SI YES JA	
A	2	27	3.6		0.55	13				0.75	850	68		NO NO NEIN	
A	3-A	61	5.5		1.1	34		G 3/4"	G 1/2"	1.1	2000	75		NO NO NEIN	
B	3-B	75	5.5	Vite Screw-type Schnecke	1.5	30		G 1"	G 1" 1/4	0.23	2700	72		SI YES JA	SI YES JA
B	4	96	15		3.0	112		G 1" 1/4	G 1" 1/2	0.23	3500	72			
B	5	118	15		3.0	112				0.56	6300	75			
B	6	127	16		3.0	160	G 1" 1/4	G 1" 1/2	7450	79					
B	7	140	20		3.0	160			0.9	9500	79				

Legenda/Legend/Legende.

- [\*1] Tipo Pompa/Pump type/Pumpentyp.
- [\*2] Potenza /Power/Leistung [kW]
- [\*3] Portata /Flow rate/Durchsatz [dm<sup>3</sup> / min]
- [\*4] Alimentazione /Power supply/Versorgung [V / Hz]
- [\*5] Aspirazione /Inlet/Ansaugung
- [\*6] Mandata /Outlet/Zulauf
- [\*7] Potenza /Power/Leistung [kW]
- [\*8] Portata Aria /Air flow rate/Luftdurchsatz [m<sup>3</sup> / h]
- [\*9] Rumorosità /Noise/Geräuschpegel [dB]

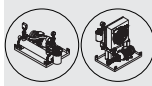

## 1.0 - Gruppo di raffreddamento

## 1.0 - Cooling Unit

## 1.0 - Kühlanlage

### 1.2.4 Dimensioni

Nelle tabelle sottostanti sono riportati gli ingombri dei gruppi:

- SCHEMA A: RFA 1, RFA 2, RFA3;
- SCHEMA B: RFA 3, RFA 4, RFA5, RFA6, RFA7;

### 1.2.4 Dimensions

The tables below show units overall dimensions:

- DIAGRAM A: RFA 1, RFA 2, RFA3;
- DIAGRAM B: RFA 3, RFA 4, RFA5, RFA6, RFA7;

### 1.2.4 Maße

In den nachstehenden Tabelle werden die Maße der Aggregate angegeben:

- SCHEMA A: RFA 1, RFA 2, RFA3;
- SCHEMA B: RFA 3, RFA 4, RFA5, RFA6, RFA7;

### SCHEMA A

### DIAGRAM A

### SCHEMA A

RFA 1

RFA 2

RFA 3-A

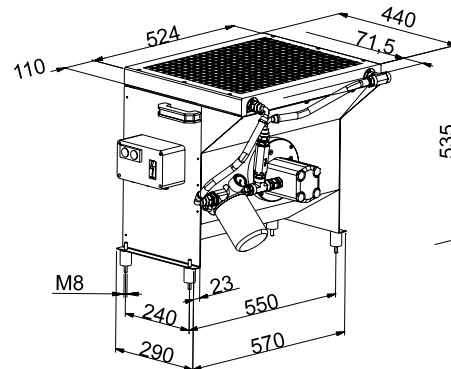
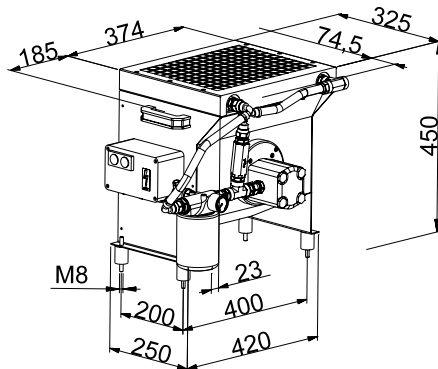
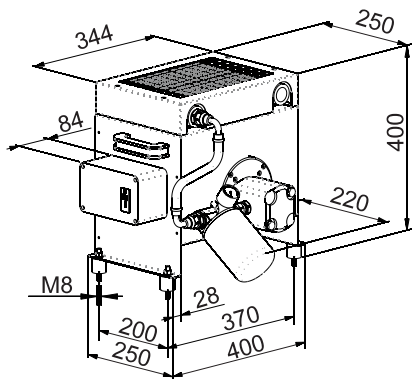

### SCHEMA B

### DIAGRAM B

### SCHEMA B

RFA 3-B

RFA 4

RFA 5

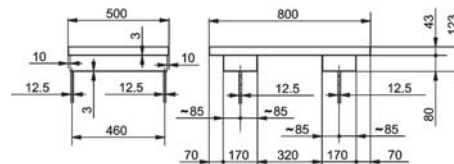
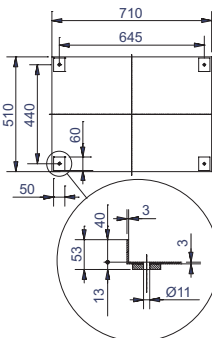
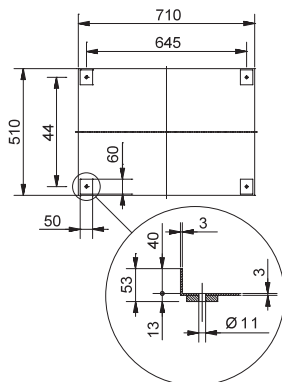
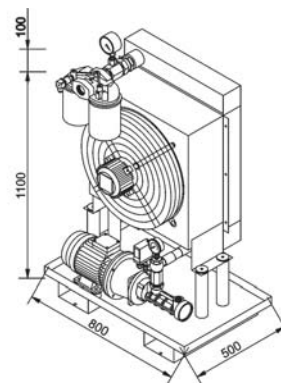
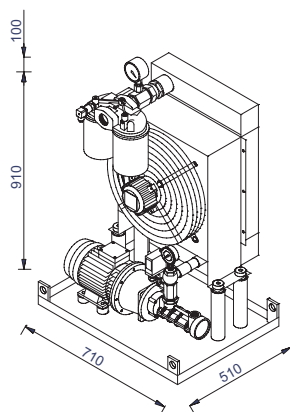
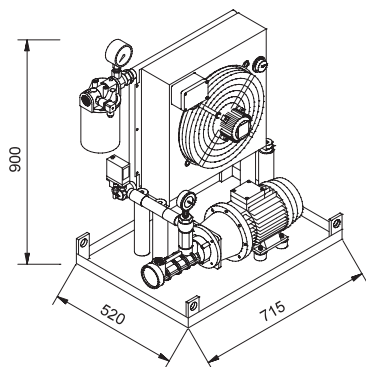

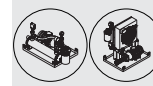

1.0 - Gruppo di raffreddamento

1.0 - Cooling Unit

1.0 - Kühlanlage

SCHEMA B

DIAGRAM B

SCHEMA B

RFA 6

RFA 7

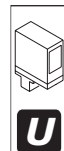
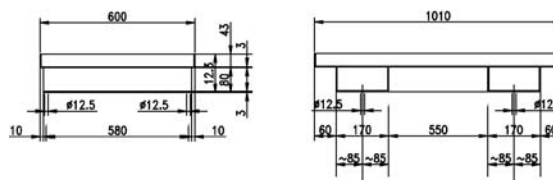
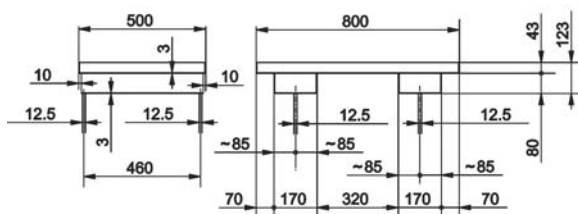
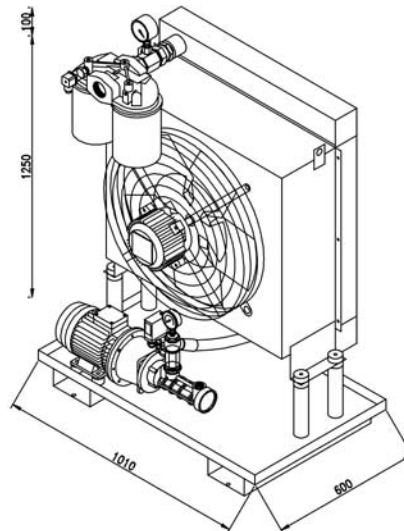
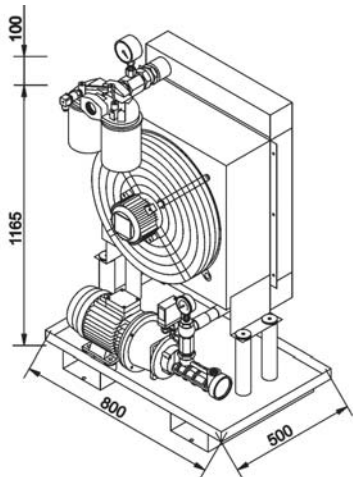





<b>ACC6</b>	<b>ACC6 - Accessori - Lubrificazione Forzata - BEARING</b>	<b>ACC6 - Accessories - Forced lubrication - BEARING</b>	<b>ACC6 - Zubehör - Zwangsschmierung - BEARING</b>
-------------	--	--	--

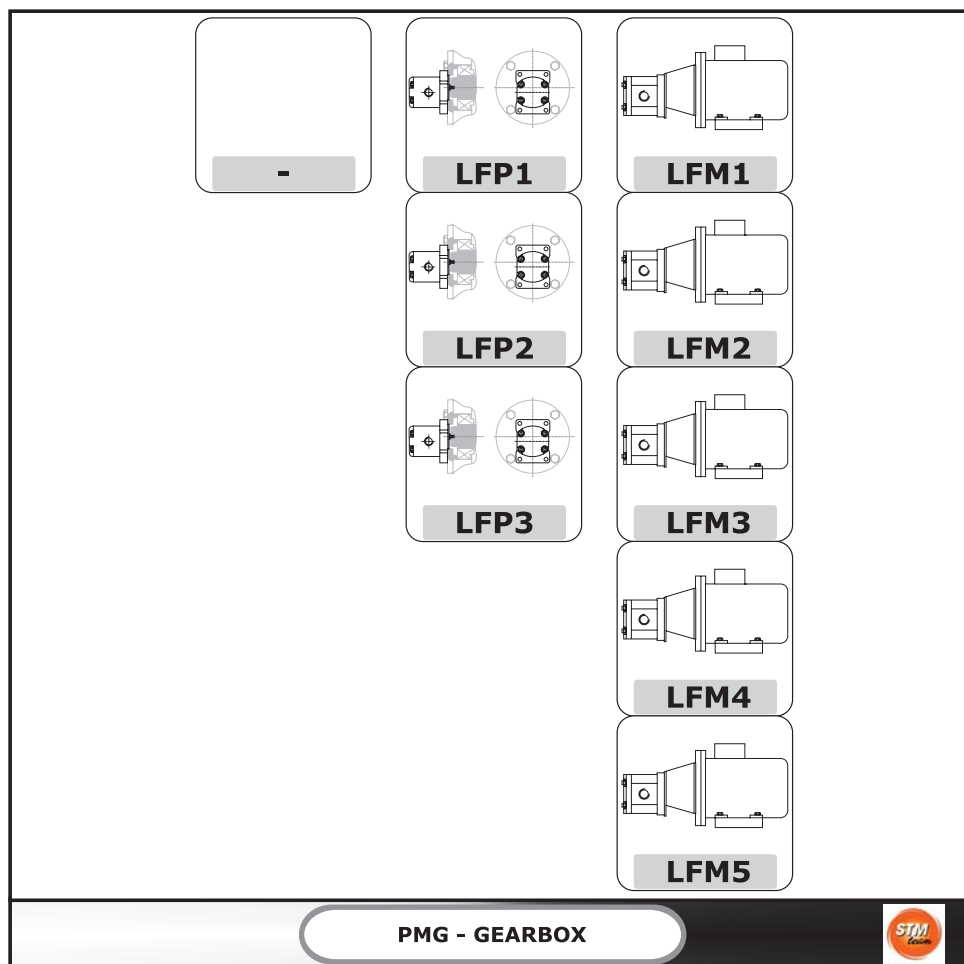

E' possibile richiedere diverse tipologie di dispositivi per consentire la lubrificazione forzata dei cuscinetti.

Possono essere forniti i seguenti accessori e dispositivi:

*It is possible to request various types of devices to allow the forced lubrication of the bearings.*

*Some devices can optionally be provided:*

Es können verschiedene Vorrichtungstypen angefordert werden, um die Zwangsschmierung der Lager zu ermöglichen.

Folgende Zubehörteile und Vorrichtungen können geliefert werden:

Code Designation	Code ORDER	I	GB	DE
LFP1		= Pompa asservita - 0.5 l/min	= Shaft-driven pump - 0.5 l/min	= Nebenpumpe- 0.5 l/min
LFP2		= Pompa asservita - 5 l/min	= Shaft-driven pump - 5 l/min	= Nebenpumpe- 1.75 l/min
LFP3		= Pompa asservita - 1.75 l/min	= Shaft-driven pump - 1.75 l/min	= Nebenpumpe- 5 l/min
LFM1		= Motopompa - 0.5 l/min	= Motor pump - 0.5 l/min	= Motorpumpe - 0.5 l/min
LFM2		= Motopompa - 5 l/min	= Motor pump - 5 l/min	= Motorpumpe - 5 l/min
LFM3		= Motopompa - 10 l/min	= Motor pump - 10 l/min	= Motorpumpe - 10 l/min
LFM4		= Motopompa - 20 l/min	= Motor pump - 20 l/min	= Motorpumpe - 20 l/min
LFM5		= Motopompa - 30 l/min	= Motor pump - 30 l/min	= Motorpumpe - 30 l/min





**2.0 - Lubrificazione forzata**

**2.0 - Forced lubrication**

**2.0 - Zwangsschmierung**

**Lubrificazione cuscinetti superiori**

**Upper bearing lubrication**

**Schmierung der obenliegenden Lager**

La lubrificazione forzata dei cuscinetti superiori viene associata alla lubrificazione forzata degli ingranaggi nel caso quest'ultima sia necessaria.

*Forced lubrication for upper bearings is normally associated with forced lubrication for the gears, where necessary.*

Die Zwangsschmierung der obenliegenden Lager wird mit der Zwangsschmierung der Zahnräder, für die erforderlich sind, assoziiert.

**Attenzione LFP1 e LFP2:**

1 - La pompa LFP1 & LFP2 è unidirezionale. L'accessorio può essere montato sul riduttore solo nel caso esso funzioni con unico senso di rotazione, il quale deve essere specificato in fase di ordine.  
2 - Per applicabilità LFP...: consultare servizio tecnico.

**Attention LFP1 e LFP2:**

1 - The LFP1 & LFP2 pump is a one-way pump. The accessory can be installed on the gearbox only if it works in a single direction of rotation, which must be specified in the order.  
2 - For LFP... applicability: contact the technical service.

**Achtung LFP1 & LFP2:**

1 - Die LFP1 & LFP2 ist eine einseitig gerichtete Pumpe. Das Zubehör kann nur am Getriebe montiert werden, wenn es mit einer einzigen Drehrichtung arbeitet, die bei der Bestellung angegeben werden muss.  
2 - Für die LFP...Anwendungsmöglichkeit: sich an den technischen Kundendienst wenden.

**2.1 - Applicabilità - LFM.**

**2.1 - Application - LFM.**

**2.1 - Applikation - LFM.**

**RXP**

Pos. Mont. M5 - M6

Mntg. Pos. M5 - M6

Einbaulage M5 - M6

	n <sub>1</sub> [min <sup>-1</sup> ]	Grandezza / Size / Baugröße											
		802-810	812	814	816	818	820	822	824	826	828	830	832
RXP3	1751 - n <sub>1max</sub>	G (grease)		LFM2		LFM2			LFM3			LFM4	
	1000 - 1750	G (grease)				LFM2			LFM3			LFM4	
	0 - 999	G (grease)						LFM2		LFM3			LFM4
RXP2	1751 - n <sub>1max</sub>	G (grease)		LFM2		LFM2			LFM3				
	1000 - 1750	G (grease)				LFM2			LFM3				
	0 - 999	G (grease)						LFM2		LFM3			
RXP1	1751 - n <sub>1max</sub>	G (grease)		LFM2		LFM2			LFM3				
	1000 - 1750	G (grease)				LFM2			LFM3				
	0 - 999	G (grease)				LFM2			LFM3				

**RXO - RXV**

Pos. Mont. / Mntg. Pos. / Einbaulage M1- M5 - M6

RXO RXV	M5 M6 M1 M5 M6	n <sub>1</sub> [min <sup>-1</sup> ]	Grandezza / Size / Baugröße											
			802-810	812	814	816	818	820	822	824	826	828	830	832
RXO3 RXV3		0 - n <sub>1max</sub>	G (grease)						LFM3			LFM4		
RXO2 RXV2		1751 - n <sub>1max</sub>	G (grease)		LFM2		LFM2			LFM3			LFM4	
		1000 - 1750	G (grease)				LFM2			LFM3			LFM4	
		0 - 999	G (grease)						LFM2		LFM3			LFM4
RXO1 RXV1		1751 - n <sub>1max</sub>	G (grease)		LFM2		LFM2			LFM3				
		1000 - 1750	G (grease)				LFM2			LFM3				
		0 - 999	G (grease)						LFM2		LFM3			

Pos. Mont. / Mntg. Pos. / Einbaulage M3 - M4

	n <sub>1</sub> [min <sup>-1</sup> ]	Grandezza / Size / Baugröße											
		802-808	810	812	814	816	818	820	822	824	826	828	830
RXO1 RXV1	1751 - n <sub>1max</sub>	G (grease)		LFM1		LFM2							
	1000 - 1750	G (grease)		LFM1		LFM2							
	0 - 999	G (grease)				LFM2							
RXO2 RXV2	1751 - n <sub>1max</sub>	G (grease)		LFM1		LFM2			LFM2				
	1000 - 1750	G (grease)				LFM1			LFM2				
	0 - 999	G (grease)		G (grease)		LFM1			LFM2			LFM3	
RXO3 RXV3	0 - n <sub>1max</sub>	G (grease)		G (grease)			LFM2			LFM3			

I valori di n<sub>1</sub> max sono riportati nel paragrafo (vedi sezione A verifiche, punto 4).

*n<sub>1</sub> max values are listed at paragraph (see Section A verification, point 4).*

Die Werte von n<sub>1</sub> max werden im Paragraph (siehe Abschnitt A „kontrollen“, Punkt 4, angegeben).





**2.0 - Lubrificazione forzata**

**2.0 - Forced lubrication**

**2.0 - Zwangsschmierung**

**2.2 - Pompa asservita**

**2.2 - Shaft-driven pump**

**2.2 - Nebenpumpe**

Questo sistema si realizza accoppiando la pompa direttamente ad un albero del riduttore, dal quale prende il moto, e si suddivide in 3 tipologie.

*The pump is coupled directly to and driven by a gear unit shaft. There are three different types of pumps available.*

Dieses System wird durch die direkte Passung der Pumpe auf eine der Getriebewellen, von der sie dann auch angetrieben wird, gestellt. Hier unterscheidet man 3 Typen.

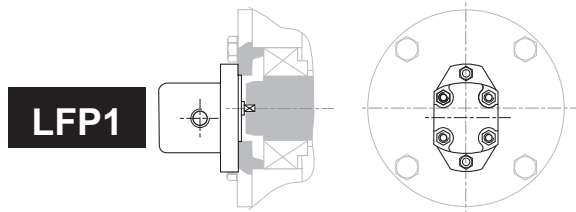

Pompa con portata di 0.5 l/min a 1500 rpm

*Pump with 0.5 l/min capacity at 1500 rpm*

Pumpe mit Durchsatz von 0,5 l/min bei 1500 U/min

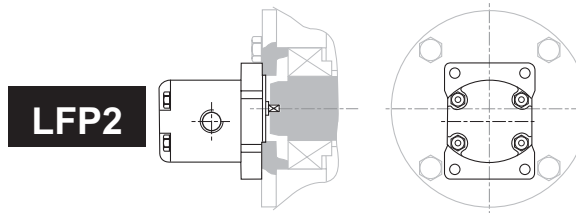

Pompa con portata di 5 l/min a 1500 rpm

*Pump with 5 l/min capacity at 1500 rpm*

Pumpe mit Durchsatz von 5 l/min bei 1500 U/min

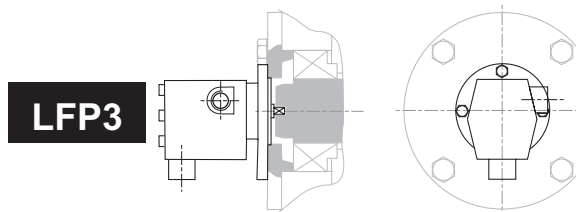

Pompa con portata di 1.75 l/min a 750 rpm

Questa pompa è particolarmente indicata per un funzionamento a basso numero di giri, viene ad esempio utilizzata nel primo stadio di riduzione cilindrico di un riduttore ortogonale

*Pump with 1.75 l/min capacity at 750 rpm*

*This pump is especially suited for low speed operation. A typical application is the first reduction spur gear set of a helical bevel gear unit.*

Pumpe mit Durchsatz von 1,75 l/min bei 750 U/min

Diese Pumpe ist besonders für einen Betrieb bei niedriger Drehzahl geeignet. Sie wird z.B. in der ersten zylindrischen Übersetzungsstufe eines Kegelstirradgetriebes verwendet.

**2.3 - Motopompa**

**2.3 - Motor pump**

**2.3 - Motorpumpe**

Questo sistema si realizza accoppiando un motore elettrico ad una pompa idraulica; si suddivide in 5 tipologie ed è fornibile anche separatamente al riduttore. Nelle tabelle sottostanti sono indicate le principali caratteristiche tecniche e le dimensioni di questi impianti.

*This is a hydraulic pump coupled with an electric motor. Available in five different types, motor pumps are also offered as a separate product. Listed in the tables below are the most significant specifications and dimensions.*

Dieses System wird durch die Passung eines Elektromotors an eine Hydraulikpumpe realisiert; es lässt sich in 5 Typologien unterteilen und kann auch getrennt vom Getriebe geliefert werden. In den nachstehenden Tabellen werden die wesentlichen technischen Eigenschaften und die Maße dieser Anlagen angegeben.

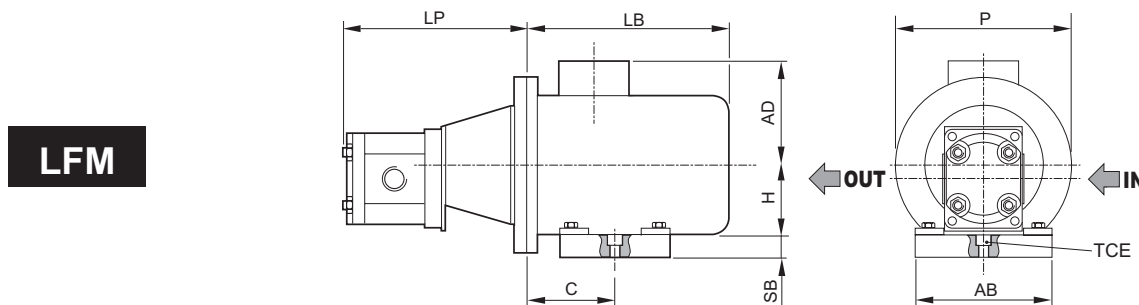

	l/min	Motor	P(kW)	A	AB	AD	BB	C	H	LB	LP	P	SB	IN	OUT	VTCE
<b>LFM1</b>	0.5	71A4	0.25	172	135	108	109	90	71	220	130	160	15	1/4"GAS	1/4"GAS	M8
<b>LFM2</b>	5				135	108	109	90	71	220	147	160	15	3/8"GAS	3/8"GAS	M8
<b>LFM3</b>	10	80A4	0.55	197	155	120	125	100	80	238	200	200	25	1/2"GAS	1/2"GAS	M10
<b>LFM4</b>	20	80B4	0.75		155	120	125	100	80	238	210	200	25	3/4"GAS	1/2"GAS	M10
<b>LFM5</b>	30	90S4	1.1		214	170	131	154	106	90	255	225	200	25	3/4"GAS	1/2"GAS

N.B.: la GSM si riserva di scegliere la tipologia più adatta di Pompa asservita e Motopompa per il buon funzionamento del riduttore.

*NOTE: STM reserves the right to select the type of shaft-driven or motor pump deemed most appropriate for proper gear unit operation at its discretion.*

HINWEIS: Die STM behält sich das Recht vor, den für den guten Getriebebetrieb angemessenen Typ der Neben- oder Motorpumpe wählen zu können.



<b>ACC6A</b>	<b>ACC6A - Accessori - Lubrificazione Forzata - GEAR</b>	<b>ACC6A - Accessories - Forced lubrication - GEAR</b>	<b>ACC6A - Zubehör - Zwangsschmierung - GEAR</b>
--------------	--	--	--



**LF.**

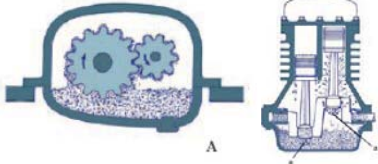

-

**PMG - GEARBOX**



Dove necessario è possibile fornire riduttori predisposti o completi di lubrificazione forzata. La lubrificazione forzata può essere effettuata con Pompa asservita o con Motopompa.

*Where necessary, gear units are supplied with provisions for or incorporated forced lubrication. Both shaft-driven and motor-driven pumps are available.*





















Wo erforderlich können die Getriebe für eine Zwangsschmierung ausgelegt oder bereits damit ausgestattet geliefert werden. Die Zwangsschmierung kann durch eine Neben- oder Motorpumpe gestellt werden.

Maggiori informazioni sugli accessori disponibili e sulla loro applicabilità sono disponibili a richiesta.

*More information on the accessories available and on their applicability is available upon request.*

Weitere Informationen zu den verfügbaren Zubehörteilen und deren Anwendungsmöglichkeiten erhalten Sie auf entsprechende Anfrage.

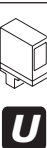

**3.0 - Accessori idraulici****3.0 - Hydraulic accessories****3.0 - Hydraulikzubehör**

ACC7-R		<b>ACC7A</b>	Accessori idraulici - Vibration Sensor	Hydraulic accessories - Vibration Sensor	Hydraulikzubehör - Vibration Sensor	<b>U18</b>
		<b>ACC7B</b>	Accessori idraulici - Vibration SWITCH	Hydraulic accessories - Vibration SWITCH	Hydraulikzubehör - Vibration SWITCH	<b>U19</b>
		<b>ACC7C</b>	Accessori idraulici - FILLING	Hydraulic accessories - FILLING	Hydraulikzubehör - FILLING	<b>U20</b>
		<b>ACC7D</b>	Accessori idraulici - PARTICLE MAGNETIC	Hydraulic accessories - PARTICLE MAGNETIC	Hydraulikzubehör - PARTICLE MAGNETIC	<b>U21</b>
		<b>ACC7E</b>	Accessori idraulici - DRAIN	Hydraulic accessories - DRAIN	Hydraulikzubehör - DRAIN	<b>U22</b>
		<b>ACC7F</b>	Accessori idraulici - BREATHER	Hydraulic accessories - BREATHER	Hydraulikzubehör - BREATHER	<b>U23</b>
		<b>ACC7G</b>	Accessori idraulici - LEVEL	Hydraulic accessories - LEVEL	Hydraulikzubehör - LEVEL	<b>U24</b>
		<b>ACC7H</b>	Accessori idraulici - HEATER	Hydraulic accessories - HEATER	Hydraulikzubehör - HEATER	<b>U25</b>
		<b>ACC7I1</b>	Accessori idraulici - TEMPERATURE SENSOR	Hydraulic accessories - TEMPERATURE SENSOR	Hydraulikzubehör - TEMPERATURE SENSOR	<b>U26</b>
		<b>ACC7I2</b>	Accessori idraulici - TEMPERATURE SWITCH	Hydraulic accessories - TEMPERATURE SWITCH	Hydraulikzubehör - TEMPERATURE SWITCH	<b>U29</b>
		<b>ACC7I3</b>	Accessori idraulici - TEMPERATURE TERMOWELL	Hydraulic accessories - TEMPERATURE TERMOWELL	Hydraulikzubehör - TEMPERATURE TERMOWELL	<b>U30</b>
		<b>ACC7L</b>	Accessori idraulici - FILTER	Hydraulic accessories - FILTER	Hydraulikzubehör - FILTER	<b>U31</b>
		<b>ACC7M1</b>	Accessori idraulici - PRESSURE SENSOR	Hydraulic accessories - PRESSURE SENSOR	Hydraulikzubehör - PRESSURE SENSOR	<b>U32</b>
		<b>ACC7M2</b>	Accessori idraulici - PRESSURE SWITCH	Hydraulic accessories - PRESSURE SWITCH	Hydraulikzubehör - PRESSURE SWITCH	<b>U33</b>
		<b>ACC7M3</b>	Accessori idraulici - PRESSURE Differential gauge	Hydraulic accessories - PRESSURE Differential gauge	Hydraulikzubehör - PRESSURE Differential gauge	<b>U34</b>
		<b>ACC7N1</b>	Accessori idraulici - FLOW SENSOR	Hydraulic accessories - FLOW SENSOR	Hydraulikzubehör - FLOW SENSOR	<b>U35</b>
		<b>ACC7N2</b>	Accessori idraulici - FLOW SWITCH	Hydraulic accessories - FLOW SWITCH	Hydraulikzubehör - FLOW SWITCH	<b>U36</b>
		<b>ACC7N3</b>	Accessori idraulici - FLOW VISUAL	Hydraulic accessories - FLOW VISUAL	Hydraulikzubehör - FLOW VISUAL	<b>U37</b>
		<b>ACC7O</b>	Accessori idraulici - COOL	Hydraulic accessories - COOL	Hydraulikzubehör - COOL	<b>U39</b>
		<b>ACC7P</b>	Accessori idraulici - LEVEL-BREATHER	Hydraulic accessories - LEVEL-BREATHER	Hydraulikzubehör - LEVEL-BREATHER	<b>U40</b>
	<b>ACC7Z</b>	Accessori idraulici - GENERIC	Hydraulic accessories - GENERIC	Hydraulikzubehör - GENERIC	<b>U41</b>	



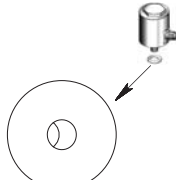

<b>ACC7A</b>	<b>Accessori idraulici - Vibration Sensor</b>	<b>Hydraulic accessories - Vibration Sensor</b>	<b>Hydraulikzubehör - Vibration Sensor</b>
--------------	---	---	--

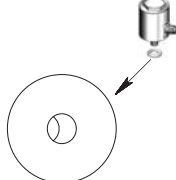
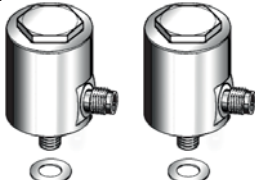
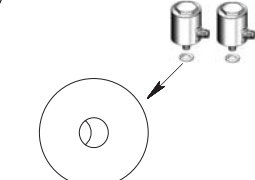
-	 <b>A_HZ1</b>	 <b>A_PHZ1</b>
	 <b>A_HZ2</b>	 <b>A_PHZ2</b>
	 <b>A_HZ</b>	 <b>A_PHZ</b>
<b>PMG - GEARBOX</b>		



Maggiori informazioni sugli accessori disponibili e sulla loro applicabilità sono disponibili a richiesta.

*More information on the accessories available and on their applicability is available upon request.*

Weitere Informationen zu den verfügbaren Zubehörteilen und deren Anwendungsmöglichkeiten erhalten Sie auf entsprechende Anfrage.

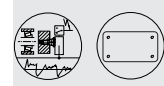

<b>ACC7B</b>	<b>Accessori idraulici - Vibration SWITCH</b>	<b>Hydraulic accessories - Vibration SWITCH</b>	<b>Hydraulikzubehör - Vibration SWITCH</b>
--------------	---	---	--

-



**V\_VS**

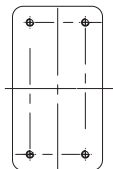

**B\_PVS1**

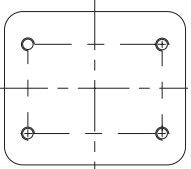

**B\_PVS2**

**PMG - GEARBOX**



Maggiori informazioni sugli accessori disponibili e sulla loro applicabilità sono disponibili a richiesta.

*More information on the accessories available and on their applicability is available upon request.*

Weitere Informationen zu den verfügbaren Zubehörteilen und deren Anwendungsmöglichkeiten erhalten Sie auf entsprechende Anfrage.

GSM\_mod.CT03-04-05-06 IGBD 0.1





RX Series

U19



ACC7C

Accessori idraulici -  
FILLINGHydraulic accessories -  
FILLINGHydraulikzubehör -  
FILLING

-	 ▼ ▽ <b>C_F1</b>
	 ▼ ▽ <b>C_F2</b>
	 ▼ ▽ <b>C_F3</b>
	 ▼ ▽ <b>C_F4</b>
<b>PMG - GEARBOX</b>	
	

Maggiori informazioni sugli accessori disponibili e sulla loro applicabilità sono disponibili a richiesta.

*More information on the accessories available and on their applicability is available upon request.*

Weitere Informationen zu den verfügbaren Zubehörteilen und deren Anwendungsmöglichkeiten erhalten Sie auf entsprechende Anfrage.





<b>ACC7D</b>	<b>Accessori idraulici - PARTICLE MAGNETIC</b>	<b>Hydraulic accessories - PARTICLE MAGNETIC</b>	<b>Hydraulikzubehör - PARTICLE MAGNETIC</b>
--------------	--	--	---

-

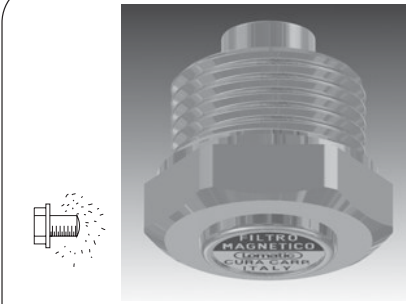

D\_M1

**PMG - GEARBOX**



Maggiori informazioni sugli accessori disponibili e sulla loro applicabilità sono disponibili a richiesta.

*More information on the accessories available and on their applicability is available upon request.*

Weitere Informationen zu den verfügbaren Zubehörteilen und deren Anwendungsmöglichkeiten erhalten Sie auf entsprechende Anfrage.



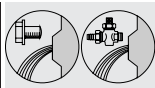

ACC7E	Accessori idraulici - DRAIN	<i>Hydraulic accessories -</i> <i>DRAIN</i>	Hydraulikzubehör - DRAIN
-------	--------------------------------	--	-----------------------------

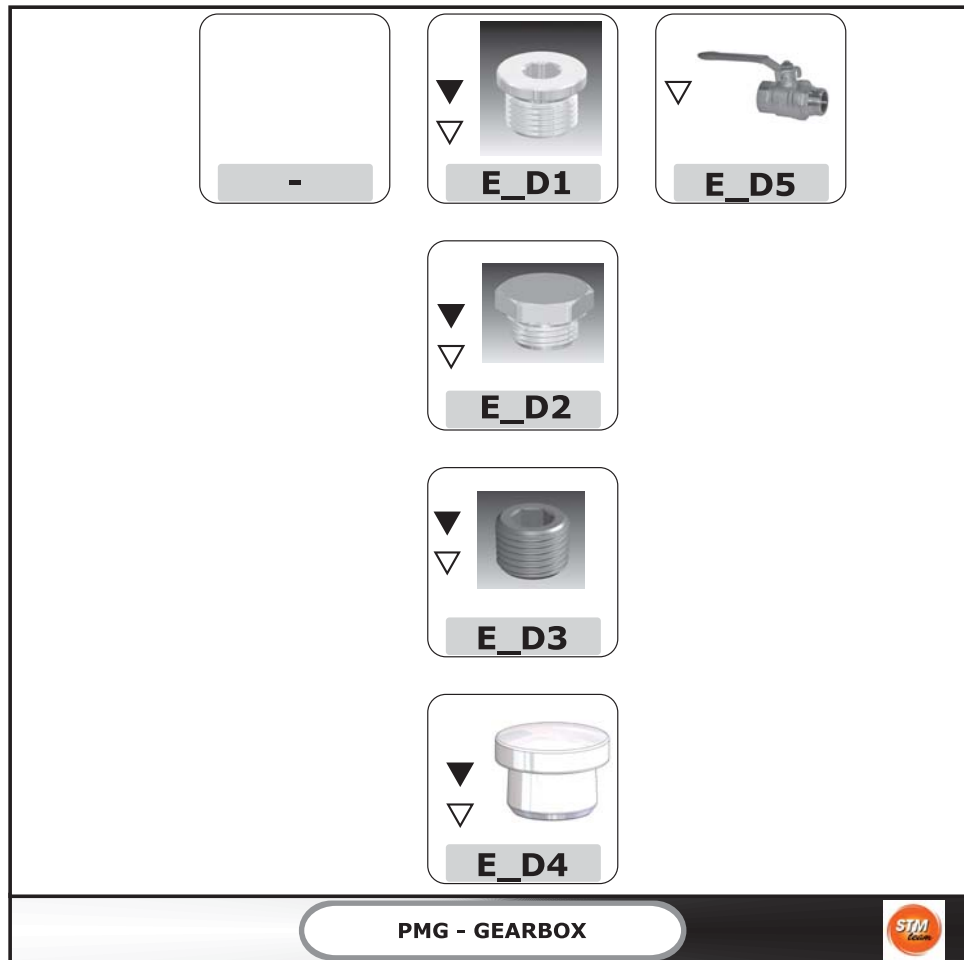

Maggiori informazioni sugli accessori disponibili e sulla loro applicabilità sono disponibili a richiesta.

*More information on the accessories available and on their applicability is available upon request.*

Weitere Informationen zu den verfügbaren Zubehörteilen und deren Anwendungsmöglichkeiten erhalten Sie auf entsprechende Anfrage.



<b>ACC7F</b>	<b>Accessori idraulici - BREATHER</b>	<b>Hydraulic accessories - BREATHER</b>	<b>Hydraulikzubehör - BREATHER</b>
--------------	---	---	--

 -	 F_T1A	 F_T2A	 F_T3A	 F_T4A	 F_T5A
	 F_T1B	 F_T2B	 F_T3B		
	 F_T1C				

**PMG - GEARBOX**



Maggiori informazioni sugli accessori disponibili e sulla loro applicabilità sono disponibili a richiesta.

*More information on the accessories available and on their applicability is available upon request.*

Weitere Informationen zu den verfügbaren Zubehörteilen und deren Anwendungsmöglichkeiten erhalten Sie auf entsprechende Anfrage.

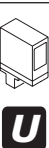

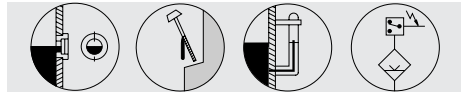

<b>ACC7G</b>	<b>Accessori idraulici - LEVEL</b>	<b>Hydraulic accessories - LEVEL</b>	<b>Hydraulikzubehör - LEVEL</b>
--------------	--	--	-------------------------------------

**PMG - GEARBOX**

Maggiori informazioni sugli accessori disponibili e sulla loro applicabilità sono disponibili a richiesta.

*More information on the accessories available and on their applicability is available upon request.*

Weitere Informationen zu den verfügbaren Zubehörteilen und deren Anwendungsmöglichkeiten erhalten Sie auf entsprechende Anfrage.



**ACC7H**

**Accessori idraulici -  
HEATER**

**Hydraulic accessories -  
HEATER**

**Hydraulikzubehör -  
HEATER**



Maggiori informazioni sugli accessori disponibili e sulla loro applicabilità sono disponibili a richiesta.





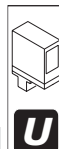

*More information on the accessories available and on their applicability is available upon request.*

Weitere Informationen zu den verfügbaren Zubehörteilen und deren Anwendungsmöglichkeiten erhalten Sie auf entsprechende Anfrage.





<b>ACC711</b>	<b>Accessori idraulici - TEMPERATURE SENSOR</b>	<b>Hydraulic accessories - TEMPERATURE SENSOR</b>	<b>Hydraulikzubehör - TEMPERATURE SENSOR</b>
---------------	---	---	--

-	 <b>I_TPT1A</b>	 <b>I_TPT2A</b>
 <b>I_TPT1B</b>	 <b>I_TPT2B</b>	 <b>I_TPT1C</b>
<div style="border: 1px solid black; border-radius: 15px; display: inline-block; padding: 5px 20px;">PMG - GEARBOX</div> 		

Maggiori informazioni sugli accessori disponibili e sulla loro applicabilità sono disponibili a richiesta.

*More information on the accessories available and on their applicability is available upon request.*

Weitere Informationen zu den verfügbaren Zubehörteilen und deren Anwendungsmöglichkeiten erhalten Sie auf entsprechende Anfrage.





<b>ACC712</b>	<b>Accessori idraulici - TEMPERATURE SWITCH</b>	<b>Hydraulic accessories - TEMPERATURE SWITCH</b>	<b>Hydraulikzubehör - TEMPERATURE SWITCH</b>
---------------	---	---	--

-	 <b>I_TSW1A</b>	 <b>I_TSW2A</b>
	 <b>I_TSW1B</b>	 <b>I_TSW2B</b>
<b>PMG - GEARBOX</b>		

Maggiori informazioni sugli accessori disponibili e sulla loro applicabilità sono disponibili a richiesta.

*More information on the accessories available and on their applicability is available upon request.*

Weitere Informationen zu den verfügbaren Zubehörteilen und deren Anwendungsmöglichkeiten erhalten Sie auf entsprechende Anfrage.

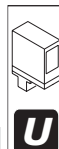



<b>ACC713</b>	<b>Accessori idraulici - TEMPERATURE TERMOWELL</b>	<b>Hydraulic accessories - TEMPERATURE TERMOWELL</b>	<b>Hydraulikzubehör - TEMPERATURE TERMOWELL</b>
---------------	--	--	---

-



I\_TLL1A

PMG - GEARBOX



Maggiori informazioni sugli accessori disponibili e sulla loro applicabilità sono disponibili a richiesta.

*More information on the accessories available and on their applicability is available upon request.*

Weitere Informationen zu den verfügbaren Zubehörteilen und deren Anwendungsmöglichkeiten erhalten Sie auf entsprechende Anfrage.



<b>ACC7L</b>	<b>Accessori idraulici - FILTER</b>	<b>Hydraulic accessories - FILTER</b>	<b>Hydraulikzubehör - FILTER</b>
--------------	---	---	--------------------------------------

-



**L\_FR1A**

PMG - GEARBOX

Maggiori informazioni sugli accessori disponibili e sulla loro applicabilità sono disponibili a richiesta.

*More information on the accessories available and on their applicability is available upon request.*

Weitere Informationen zu den verfügbaren Zubehörteilen und deren Anwendungsmöglichkeiten erhalten Sie auf entsprechende Anfrage.





<b>ACC7M1</b>	<b>Accessori idraulici - PRESSURE SENSOR</b>	<b>Hydraulic accessories - PRESSURE SENSOR</b>	<b>Hydraulikzubehör - PRESSURE SENSOR</b>
---------------	--	--	---

 <p data-bbox="399 645 606 696">-</p>	 <p data-bbox="703 645 916 689"><b>M_PSR1A</b></p>	 <p data-bbox="1011 645 1224 689"><b>M_PSR1B</b></p>
<p><b>PMG - GEARBOX</b></p>		







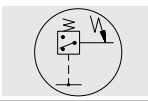

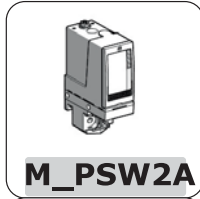

Maggiori informazioni sugli accessori disponibili e sulla loro applicabilità sono disponibili a richiesta.

*More information on the accessories available and on their applicability is available upon request.*

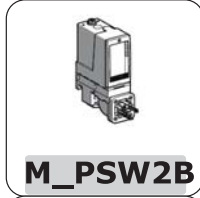
Weitere Informationen zu den verfügbaren Zubehörteilen und deren Anwendungsmöglichkeiten erhalten Sie auf entsprechende Anfrage.



<b>ACC7M2</b>	<b>Accessori idraulici - PRESSURE SWITCH</b>	<b>Hydraulic accessories - PRESSURE SWITCH</b>	<b>Hydraulikzubehör - PRESSURE SWITCH</b>
---------------	--	--	---

-	 <b>M_PSW1A</b>	 <b>M_PSW1D</b>	 <b>M_PSW2A</b>
	 <b>M_PSW1B</b>	 <b>M_PSW1E</b>	 <b>M_PSW2B</b>
	 <b>M_PSW1C</b>	 <b>M_PSW1F</b>	 <b>M_PSW2C</b>
		 <b>M_PSW1G</b>	
<b>PMG - GEARBOX</b>			

Maggiori informazioni sugli accessori disponibili e sulla loro applicabilità sono disponibili a richiesta.

*More information on the accessories available and on their applicability is available upon request.*

Weitere Informationen zu den verfügbaren Zubehörteilen und deren Anwendungsmöglichkeiten erhalten Sie auf entsprechende Anfrage.

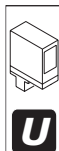



<b>ACC7M3</b>	<b>Accessori idraulici - PRESSURE Differential gauge</b>	<b>Hydraulic accessories - PRESSURE Differential gauge</b>	<b>Hydraulikzubehör - PRESSURE Differential gauge</b>
---------------	--	--	---

-



M\_PDG1A

PMG - GEARBOX



Maggiori informazioni sugli accessori disponibili e sulla loro applicabilità sono disponibili a richiesta.

*More information on the accessories available and on their applicability is available upon request.*

Weitere Informationen zu den verfügbaren Zubehörteilen und deren Anwendungsmöglichkeiten erhalten Sie auf entsprechende Anfrage.



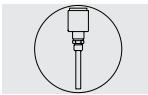

<b>ACC7N1</b>	<b>Accessori idraulici - FLOW SENSOR</b>	<b>Hydraulic accessories - FLOW SENSOR</b>	<b>Hydraulikzubehör - FLOW SENSOR</b>
---------------	--	--	---

-



N\_FSR1A

PMG - GEARBOX



Maggiori informazioni sugli accessori disponibili e sulla loro applicabilità sono disponibili a richiesta.

*More information on the accessories available and on their applicability is available upon request.*

Weitere Informationen zu den verfügbaren Zubehörteilen und deren Anwendungsmöglichkeiten erhalten Sie auf entsprechende Anfrage.

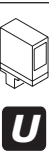



<b>ACC7N2</b>	<b>Accessori idraulici - FLOW SWITCH</b>	<b>Hydraulic accessories - FLOW SWITCH</b>	<b>Hydraulikzubehör - FLOW SWITCH</b>
---------------	--	--	---

 <p style="font-size: 2em; font-weight: bold;">-</p>	 <p style="font-size: 1.5em; font-weight: bold;">N_FSW1A</p>	 <p style="font-size: 1.5em; font-weight: bold;">N_FSW2A</p>
 <p style="font-size: 1.5em; font-weight: bold;">N_FSW1B</p>		
<p><b>PMG - GEARBOX</b></p>		



Maggiori informazioni sugli accessori disponibili e sulla loro applicabilità sono disponibili a richiesta.

*More information on the accessories available and on their applicability is available upon request.*

Weitere Informationen zu den verfügbaren Zubehörteilen und deren Anwendungsmöglichkeiten erhalten Sie auf entsprechende Anfrage.

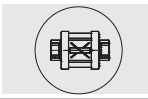

<b>ACC7N3</b>	<b>Accessori idraulici - FLOW VISUAL</b>	<b>Hydraulic accessories - FLOW VISUAL</b>	<b>Hydraulikzubehör - FLOW VISUAL</b>
---------------	--	--	---

-



N\_FVDP1A

PMG - GEARBOX



Maggiori informazioni sugli accessori disponibili e sulla loro applicabilità sono disponibili a richiesta.

*More information on the accessories available and on their applicability is available upon request.*

Weitere Informationen zu den verfügbaren Zubehörteilen und deren Anwendungsmöglichkeiten erhalten Sie auf entsprechende Anfrage.





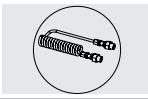

<b>ACC70</b>	<b>Accessori idraulici - COOL</b>	<b>Hydraulic accessories - COOL</b>	<b>Hydraulikzubehör - COOL</b>
--------------	---------------------------------------	---	------------------------------------

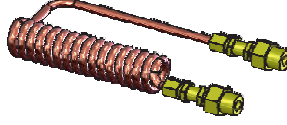
-	 <b>O_CO1A</b>
<b>PMG - GEARBOX</b>	



Maggiori informazioni sugli accessori disponibili e sulla loro applicabilità sono disponibili a richiesta.

*More information on the accessories available and on their applicability is available upon request.*

Weitere Informationen zu den verfügbaren Zubehörteilen und deren Anwendungsmöglichkeiten erhalten Sie auf entsprechende Anfrage.





**ACC7P**

**Accessori idraulici -  
LEVEL-BREATHER**

**Hydraulic accessories -  
LEVEL-BREATHER**

**Hydraulikzubehör -  
LEVEL-BREATHER**

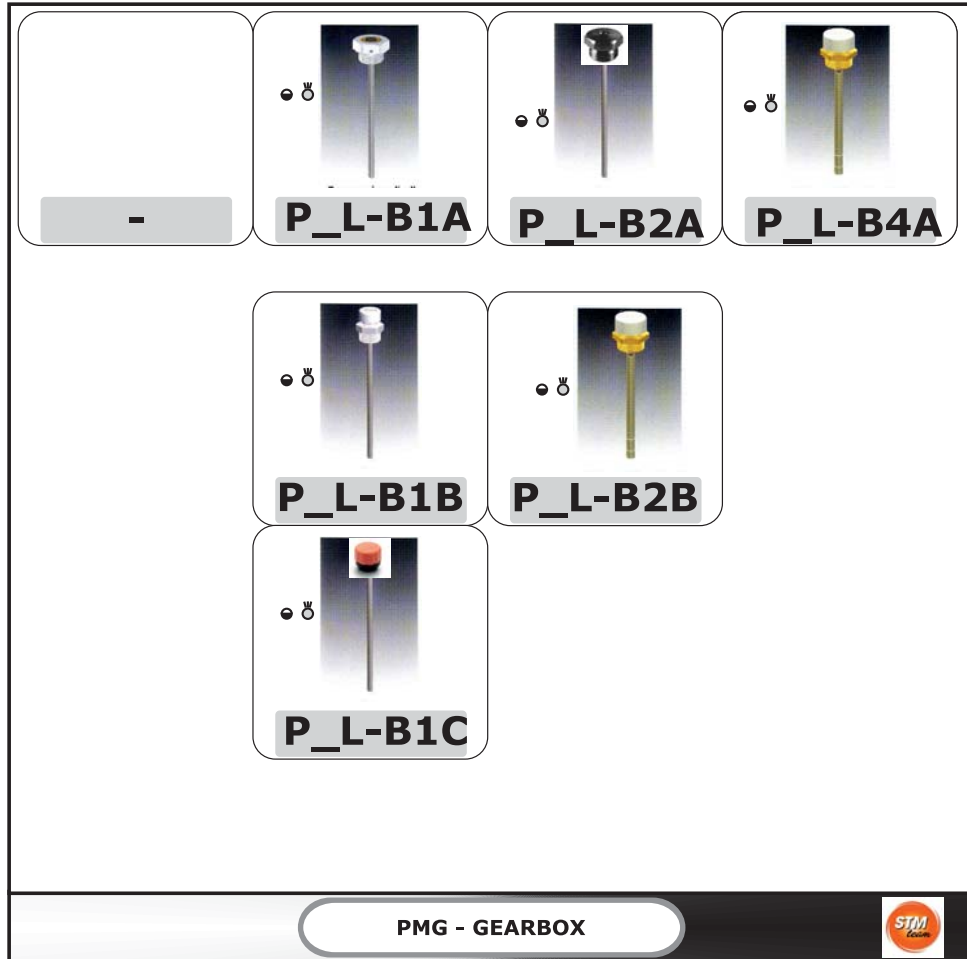

Maggiori informazioni sugli accessori disponibili e sulla loro applicabilità sono disponibili a richiesta.



*More information on the accessories available and on their applicability is available upon request.*

Weitere Informationen zu den verfügbaren Zubehörteilen und deren Anwendungsmöglichkeiten erhalten Sie auf entsprechende Anfrage.

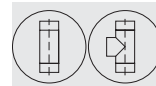

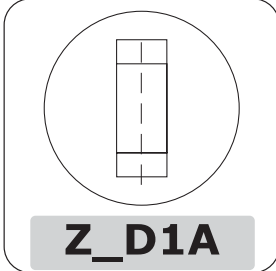
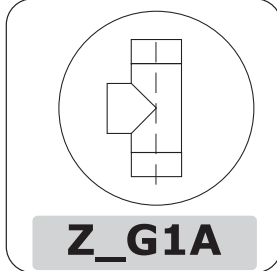

<b>ACC7Z</b>	<b>Accessori idraulici - GENERIC</b>	<b>Hydraulic accessories - GENERIC</b>	<b>Hydraulikzubehör - GENERIC</b>
--------------	--	--	---------------------------------------

 <div style="background-color: gray; color: white; padding: 5px; margin: 5px auto; width: 50px; text-align: center;">-</div>	 <div style="background-color: gray; color: white; padding: 5px; margin: 5px auto; width: 50px; text-align: center;"><b>Z_D1A</b></div>	 <div style="background-color: gray; color: white; padding: 5px; margin: 5px auto; width: 50px; text-align: center;"><b>Z_G1A</b></div>
<div style="background-color: gray; color: white; padding: 5px; border-radius: 15px; display: inline-block;">PMG - GEARBOX</div>		

Maggiori informazioni sugli accessori disponibili e sulla loro applicabilità sono disponibili a richiesta.

*More information on the accessories available and on their applicability is available upon request.*



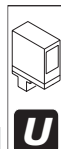





Weitere Informationen zu den verfügbaren Zubehörteilen und deren Anwendungsmöglichkeiten erhalten Sie auf entsprechende Anfrage.

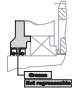

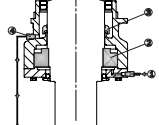
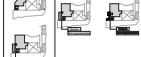
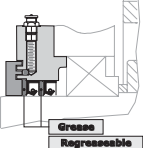

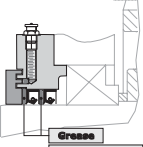

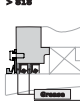
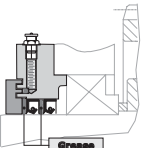
<b>ACC8</b>	<b>ACC8 - Accessori - Tipo Tenute</b>	<b>ACC8 - Accessories - Seal Type</b>	<b>ACC8 - Zubehör - Typ von Dichtung</b>
-------------	---	---	--

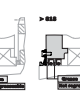
<p>STM</p> 		<p>A</p> 	<p>B</p> 	
<p>GSM A_PAM</p> 	 <p style="text-align: center;"><b>LB1</b></p>	<p style="text-align: center;"><b>DT1</b></p>		<p style="text-align: center;"><b>DW</b></p>
<p>GSM B_ECE</p> 	<p style="text-align: center;">-</p>	 <p style="text-align: center;"><b>LB2</b></p>	<p>002 + 010</p> 	<p>&gt; 010</p> 
		<p style="text-align: center;"><b>LB</b></p>	<p style="text-align: center;"><b>DT2</b></p>	
		 <p style="text-align: center;"><b>LB</b></p>	<p>B</p> 	<p>A</p> 
			<p style="text-align: center;"><b>DT</b></p>	

**PMG - GEARBOX**



E' possibile richiedere diverse tipologie costruttive per realizzare la tenuta dinamica del riduttore.

*It is possible to request various types of manufacturing to ensure the dynamic tightness of the gearbox.*

Es können verschiedene Bauarten angefordert werden, um die dynamische Dichtigkeit des Getriebes zu erhalten.

Possono essere forniti i seguenti accessori e dispositivi:

*Some devices can optionally be provided:*

Folgende Zubehörteile und Vorrichtungen können geliefert werden:

Code Designation	Code ORDER	I	GB	DE
<b>LB1</b>		= Doppio anello di tenuta con labbro parapolvere con tenuta a labirinto in Entrata	= Double dust lip seal with Labyrinth seal - Input Shaft	= Doppeldichtung mit Staublippe mit Labyrinth-Dichtung - Antriebwelle
<b>LB2</b>		= Doppio anello di tenuta con labbro parapolvere con tenuta a labirinto in Uscita	= Double dust lip seal with Labyrinth seal - Output Shaft	= Doppeldichtung mit Staublippe mit Labyrinth-Dichtung - Abtriebwelle
<b>LB</b>		= Doppio anello di tenuta con labbro parapolvere con tenuta a labirinto in Albero Entrata + Albero Uscita	= Double dust lip seal with Labyrinth seal - Input shaft + Output shaft	= Doppeldichtung mit Staublippe mit Labyrinth-Dichtung - Antriebswelle + Abtriebswelle
<b>DT1</b>		= Doppio anello di tenuta con labbro parapolvere in Entrata	= Double dust lip seal - Input Shaft	= Doppeldichtung mit Staublippe - Antriebwelle
<b>DT2</b>		= Doppio anello di tenuta con labbro parapolvere e coperchio di protezione in Uscita	= Double dust lip seal with dust protection - Output Shaft	= Doppeldichtung mit Staublippe und Schutzabdeckung - Abtriebwelle
<b>DT</b>		= Doppio anello di tenuta con labbro parapolvere e coperchio di protezione in Albero Entrata + Albero Uscita	= Double dust lip seal with dust protection - Input shaft + Output shaft	= Doppeldichtung mit Staublippe Antriebswelle und Schutzabdeckung + Abtriebswelle
<b>DW</b>		= Dry-Well	= Dry-Well	= Dichtungsstoffe



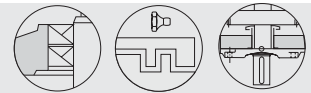

**4.0 - Anelli di tenuta**

**4.0 - Seals**

**4.0 - Dichtringe**

**4.1 - Applicabilità**

**4.1 - Application**

**4.1 - Applikation**

	RXP1	RXP2 - RXP3	RXP4	RX01 - RXV1	RX02 - RXV2 RX03 - RXV3
DT1					
DT2					
DT					
LB1					
LB2					
LB					
DW	A richiesta / On request / Auf Anfrage				

**4.2 - Albero Entrata**

**4.2 - Input shaft**

**4.2 - Antriebswelle**

INPUT - PAM	INPUT - ECE		
Standard	Standard	Dust-proof	Radial labyrinth seal
<p>Un solo anello di tenuta con labbro parapolvere <i>One dust lip seal</i> <i>Ein einziger Dichtring mit Staublippe</i></p>	<p>Un solo anello di tenuta con labbro parapolvere e coperchio di protezione <i>One dust lip seal with dust protection</i> <i>Ein einziger Dichtring mit Staublippe und Schutzabdeckung</i></p>	<p>Doppio anello di tenuta con labbro parapolvere. <i>Double dust lip seal</i> <i>Doppeldichtung mit Staublippe</i></p>	<p>Doppio anello di tenuta con labbro parapolvere con tenuta a labirinto. <i>Double dust lip seal with Labyrinth seal</i> <i>Doppeldichtung mit Staublippe mit Labyrinth-Dichtung</i></p>
	<p>Ambiente abbastanza polveroso <b>Medium</b> dust load with abrasive particles Ziemlich staubiges Umfeld</p>	<p>Ambiente molto polveroso <b>High</b> dust load with abrasive particles Sehr staubiges Umfeld</p>	<p>Ambiente estremamente polveroso <b>Very High</b> dust load with abrasive particles Extrem staubiges Umfeld</p>
		<p style="background-color: black; color: white; padding: 2px;"><b>DT1 RXO-RXV</b></p>	<p style="background-color: black; color: white; padding: 2px;"><b>LB1</b></p>
	<p><b>Grease</b> <b>Not regreaseable</b></p>	<p><b>Grease</b> <b>Not regreaseable</b></p>	<p><b>Grease</b> <b>Regreaseable</b></p>
		<p>Doppio anello di tenuta con labbro parapolvere e coperchio protezione. <i>Double dust lip seal with dust protection</i> <i>Doppeldichtung mit Staublippe und Schutzabdeckung</i></p> <p>Ambiente molto polveroso. <b>High</b> dust load with abrasive particles Sehr staubiges Umfeld</p> <p style="background-color: black; color: white; padding: 2px;"><b>DT1 RXP</b></p> <p style="text-align: center;"><b>Grease</b> <b>Not regreaseable</b></p>	



4.0 - Anelli di tenuta

4.0 - Seals

4.0 - Dichtringe

4.3 - Albero Uscita

4.3 - Output shaft

4.3 - Abtriebswelle

OUTPUT		
Standard	Dust-proof	Radial labyrinth seal
<p>Un solo anello di tenuta con labbro parapolvere e coperchio di protezione <i>One dust lip seal with dust protection</i> <i>Ein einziger Dichtring mit Staublippe und Schutzabdeckung.</i></p> <p>Ambiente abbastanza polveroso <b>Medium</b> dust load with abrasive particles Ziemlich staubiges Umfeld</p>	<p>Doppio anello di tenuta con labbro parapolvere e coperchio di protezione <i>Double dust lip seal with dust protection</i> <i>Doppeldichtung mit Staublippe und Schutzabdeckung.</i></p> <p>Ambiente molto polveroso <b>High</b> dust load with abrasive particles Sehr staubiges Umfeld</p>	<p>Doppio anello di tenuta con labbro parapolvere con tenuta a labirinto. <i>Double dust lip seal with Labyrinth seal</i> <i>Doppeldichtung mit Staublippe und Labyrinth-Dichtung</i></p> <p>Ambiente estremamente polveroso <b>Very High</b> dust load with abrasive particles</p>
<p><b>802 ÷ 818</b></p> <p><b>Grease</b> <b>Not regreaseable</b></p>	<p><b>802 ÷ 818</b> <b>DT2</b></p> <p><b>Grease</b> <b>Not regreaseable</b></p>	<p><b>LB2</b></p> <p><b>Grease</b> <b>Regreaseable</b></p>
<p>Un solo anello di tenuta con labbro parapolvere e coperchio di protezione <i>One dust lip seal with dust protection</i> <i>Ein einziger Dichtring mit Staublippe und Schutzabdeckung.</i></p> <p>Ambiente abbastanza polveroso <b>Medium</b> dust load with abrasive particles Ziemlich staubiges Umfeld</p>	<p>Doppio anello di tenuta con labbro parapolvere e coperchio di protezione <i>Double dust lip seal with dust protection</i> <i>Doppeldichtung mit Staublippe und Schutzabdeckung.</i></p> <p>Ambiente molto polveroso <b>High</b> dust load with abrasive particles Sehr staubiges Umfeld</p>	
<p><b>&gt; 818</b></p> <p><b>Grease</b> <b>Not regreaseable</b></p>	<p><b>&gt; 818</b> <b>DT2</b></p> <p><b>Grease</b> <b>Not regreaseable</b></p>	

4.4 - Albero Entrata + Albero Uscita

4.4 - Input shaft + Output shaft

4.4 - Antriebswelle + Abtriebswelle

<b>DT</b>	( DT1+DT2 ) Doppia tenuta in entrata ed in uscita	( DT1+DT2 ) Double seal at input and output end	( DT1+DT2 ) Doppeldichtung in An- und Abtrieb
<b>LB</b>	( LB1+LB2 ) Tenuta a labirinto in entrata ed in uscita	( LB1+LB2 ) <i>Labyrinth seal at input and output end</i>	( LB1+LB2 ) Labyrinthdichtung in An- und Abtrieb



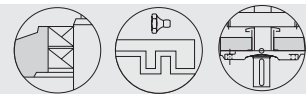

4.0 - Anelli di tenuta

4.0 - Seals

4.0 - Dichtringe

4.6 - Dry-Well

4.6 - Dry-Well

4.6 - Dichtungstoffe

DW

Questo dispositivo garantisce la tenuta dell'albero lento sporgente. E' disponibile, in posizione di montaggio M5 ed associato ad una lubrificazione forzata, solo per alcune taglie e qualche rapporto (interpellare il ns. servizio tecnico). Si rende necessario verificare/ripristinare la carica di grasso al cuscinetto inferiore dell'asse lento.

*The dry-well feature prevents oil leakage at the solid output shaft. It is available for some particular sizes and ratios in mounting position M5 and in combination with forced lubrication (please contact our Engineering for more details). Please note that the grease charge of the output shaft lower bearing must be checked/refilled.*

Diese Vorrichtung gewährleistet die Abdichtung der hervorstehenden Abtriebswelle. Sie ist, in der Einbaulage M5 verfügbar und an eine Zwangsschmierung gebunden, nur für einige Baugrößen und ein paar Übersetzungen verfügbar (unseren Technischen Kundendienst befragen). Hier ist eine Kontrolle/Nachfüllung der Fettfüllung des unteren Lagers der Abtriebsachse erforderlich.

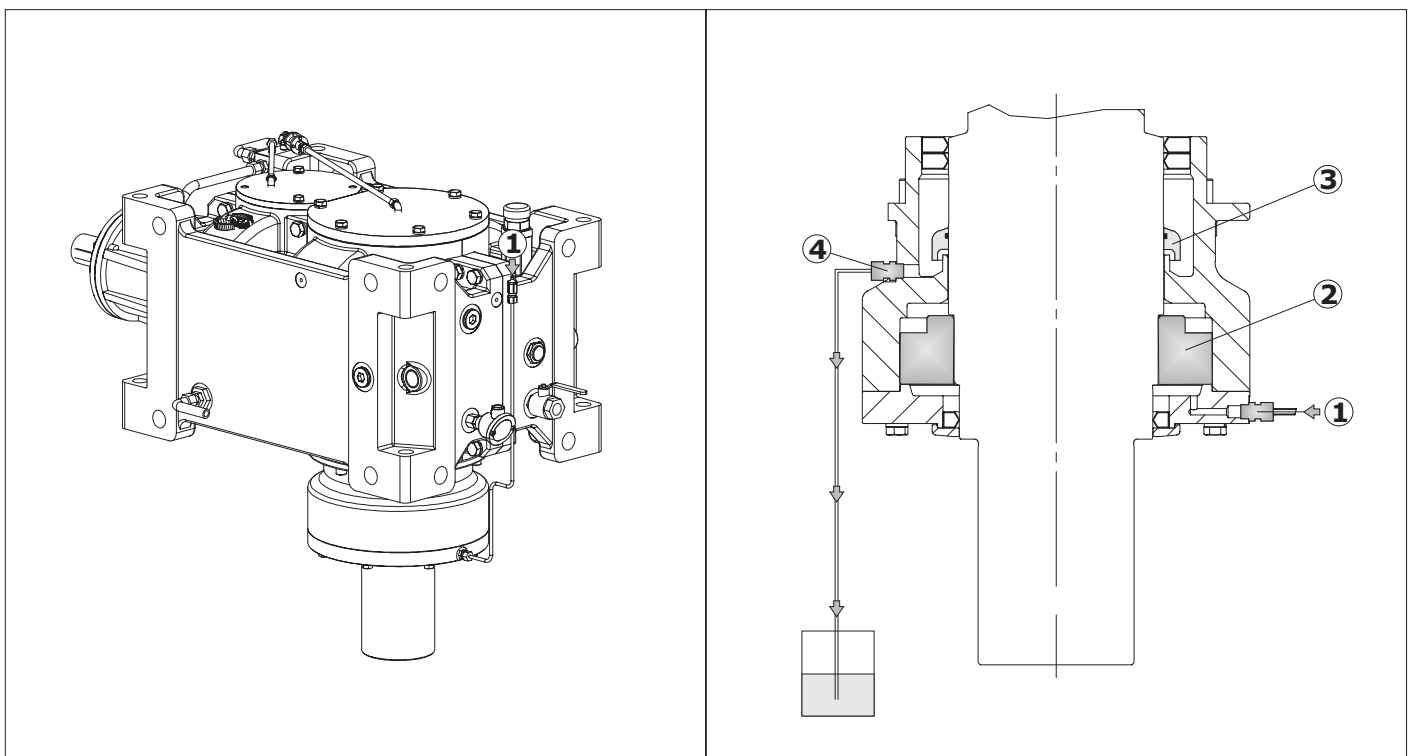

1	Ingrassatore - Cuscinetto	Grease nipple – Bearing	Schmierer – Lager
2	Cuscinetto	Bearing	Lager
3	Dispositivo Centrifugatore olio	Oil slinger device	Ölabweisringvorrichtung
4	Drenaggio olio - Sicurezza	Oil Drain - Security	Ölablass – Sicherheit





4.0 - Anelli di tenuta

4.0 - Seals

4.0 - Dichtringe

ACC8A

Accessori - Static  
Seal COMPOUNDAccessories - Static  
Seal COMPOUNDZubehör - Static  
Seal COMPOUND

-

SP\_1A

SL\_1A

PMG - GEARBOX



Maggiori informazioni sugli accessori disponibili e sulla loro applicabilità sono disponibili a richiesta.



*More information on the accessories available and on their applicability is available upon request.*

Weitere Informationen zu den verfügbaren Zubehörteilen und deren Anwendungsmöglichkeiten erhalten Sie auf entsprechende Anfrage.



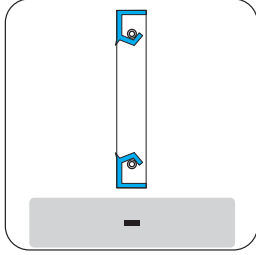
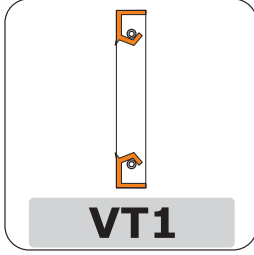
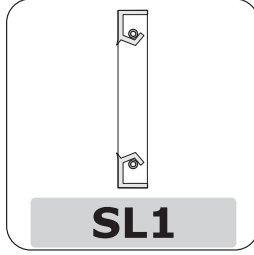
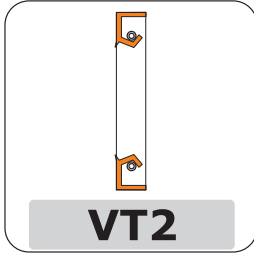
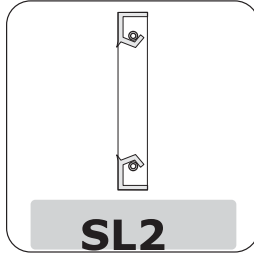
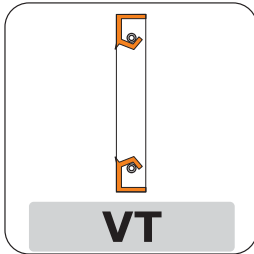
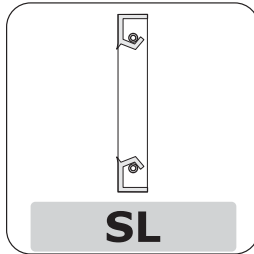

OPT	OPT - Opzioni - Materiale degli anelli di tenuta	OPT - Options - Materials of Seals	OPT - Optionen - Dichtungsstoffe
-----	--	---------------------------------------	-------------------------------------

 -	 VT1	 SL1
	 VT2	 SL2
	 VT	 SL
PMG - GEARBOX		

E' possibile richiedere materiali opzionali per gli anelli per la tenuta dinamica del riduttore.

*It is possible to request optional materials for the dynamic sealing seal rings of gearbox.*

Es können Dichtringe aus optionalen Materialien für die dynamische Dichtigkeit des Getriebes angefordert werden.

Possono essere forniti i seguenti accessori e dispositivi:

*Some devices can optionally be provided:*

Folgende Zubehörteile und Vorrichtungen können geliefert werden:

Code Designation	Code ORDER	I	GB	DE
VT1		= Paraoli in viton in entrata	= Viton oil seals at input end	= Ölabdichtungen aus Viton im Antrieb
VT2		= Paraoli in viton in uscita	= Viton oil seals at output end	= Ölabdichtungen aus Viton im Abtrieb
VT		= Paraoli in viton in entrata ed in uscita	= Viton oil seals at input and output end	= Ölabdichtungen aus Viton im An- und Abtrieb
SL1		= Paraoli in silicone in entrata	= Input Silicon oil seals	= Eingehender Silikon-Dichtungsring
SL2		= Paraoli in silicone in uscita	= Output Silicon oil seals	= Ausgehender Silikon-Dichtungsring
SL		= Tenute in Silicone in Entrata - Uscita	= Inpu and Output Silicon oil seals	= Ein- und ausgehende Silikon-Dichtungsringe



**4.0 - Anelli di tenuta**

**4.0 - Seals**

**4.0 - Dichtringe**

**4.1 - Applicabilità**

**4.1 - Application**

**4.1 - Applikation**

	RXP1	RXP2 - RXP3	RXP4	RX01 - RXV1	RX02 - RXV2 RX03 - RXV3
VT1	A richiesta On request Auf Anfrage				
VT2					
VT				A richiesta On request Auf Anfrage	
SL1					
SL2					
SL					A richiesta On request Auf Anfrage

**4.2 - Materiale degli anelli di tenuta**

**4.2 - Materials of Seals**

**4.2 - Dichtungsstoffe**

Serie Series Baureihe	OPT Opzioni - Materiale degli anelli di tenuta Options - Materials of Seals Optionen - Dichtungsstoffe	
	(Tenute STANDARD Oil Seals Standard Ölabdichtungen Standard)	Opzioni - Disponibile Options Available Optionen - verfügbar  A richiesta On request Auf Anfrage
RX 700	(VT1 - NBR2)	VT2 - SL1- SL2 - SL

Serie Series Baureihe	OPT Opzioni - Materiale degli anelli di tenuta Options - Materials of Seals Optionen - Dichtungsstoffe	
	(Tenute STANDARD Oil Seals Standard Ölabdichtungen Standard)	Opzioni - Disponibile Options Available Optionen - verfügbar  A richiesta On request Auf Anfrage
RX 800	(NBR)	VT1 - VT2 - VT - SL1- SL2 - SL

<b>NBR1</b>	Paraoli in NBR in entrata	NBR oil seals at input end	Ölabdichtungen aus NBR im Antrieb
<b>NBR2</b>	Paraoli in NBR in uscita	NBR oil seals at output end	Ölabdichtungen aus NBR im Abtrieb
<b>NBR</b>	Paraoli in NBR in entrata ed in uscita	NBR oil seals at input and output end	Ölabdichtungen aus NBR im An- und Abtrieb
<b>VT1</b>	Paraoli in viton in entrata	Viton oil seals at input end	Ölabdichtungen aus Viton im Antrieb
<b>VT2</b>	Paraoli in viton in uscita	Viton oil seals at output end	Ölabdichtungen aus Viton im Abtrieb
<b>VT</b>	Paraoli in viton in entrata ed in uscita	Viton oil seals at input and output end	Ölabdichtungen aus Viton im An- und Abtrieb
<b>SL1</b>	Paraoli in silicone in entrata	Input Silicon oil seals	Eingehender Silikon-Dichtungsring
<b>SL2</b>	Paraoli in silicone in uscita	Output Silicon oil seals	Ausgehender Silikon-Dichtungsring
<b>SL</b>	Paraoli in silicone in entrata ed in uscita	Input and output oil seals	Ein- und ausgehende Silikon-Dichtungsringe

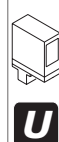

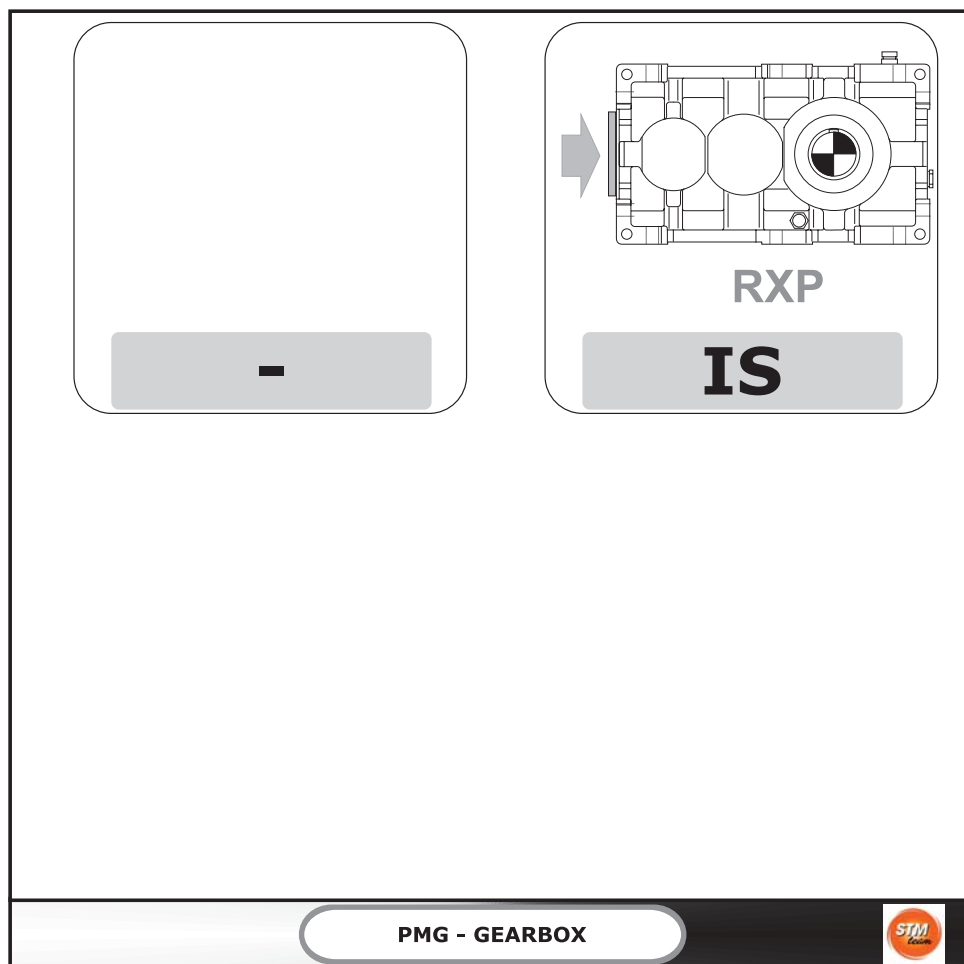

<b>ACC9A</b>	<b>Accessori generali - Coperchio di ispezione</b>	<b>Accessories custom- Inspection Cover</b>	<b>Zübehör custom - Inspektionsdeckel</b>
--------------	--	---	---

**IS****Standard**

Sono forniti standard su RXP e RXV coperchi d'ispezione lato entrata ortogonale.

**Richiesta**

Per RXO e riduttori con cassa in acciaio sono fornibili a richiesta coperchi come da schema.

**Standard**

*Inspection covers at right-angle input end supplied on RXP and RXV as standard.*

**On request**

*For RXO and steel casing gear unit, inspection covers as shown available on request.*

**Standard**

Bei den RXP- und RXV-Getrieben gehören die Inspektionsdeckel an der Winkelantriebsseite zur Standardausstattung.

**Auf Anfrage**

Bei den RXO -Getrieben mit Stahlgehäuse können die Deckel auf Anfrage geliefert werden, siehe Schema.

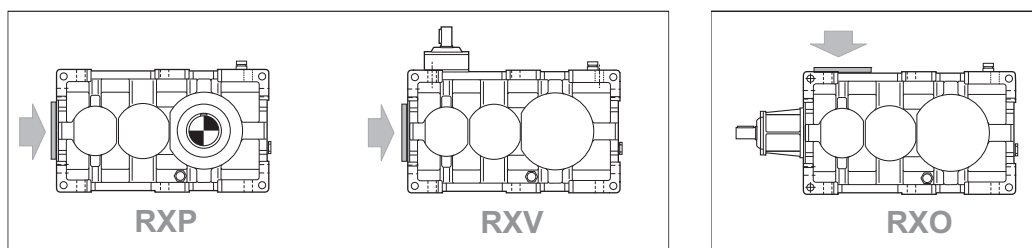
**Standard**

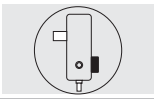



7.0 - Flangia freno (a disegno cliente)

7.0 - Brake flange (made to customer drawing)

7.0 - Bremsenflansch (gemäß Kundenzeichnung)

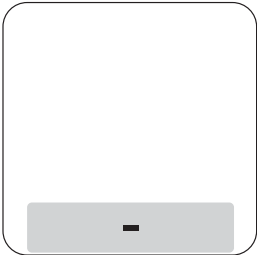
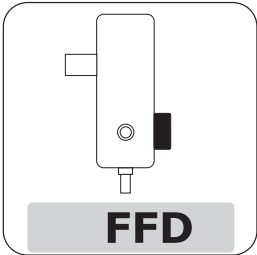
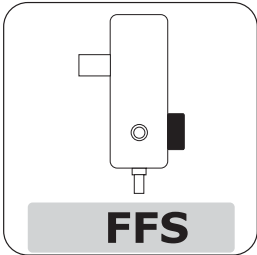
<b>ACC9B</b>	<b>Accessori generali - Flangia freno</b>	<b>Accessories custom - Brake Flange</b>	<b>Zübehör custom - Bremsflansch</b>
--------------	---	--	--

 -	 <b>FFD</b>	 <b>FFS</b>
<b>PMG - GEARBOX</b>		
		





### 7.0 - Flangia freno (a disegno cliente)

FF.

A richiesta è possibile una predisposizione per poter assemblare direttamente diverse tipologie di freno al riduttore.

### 7.0 - Brake flange (made to customer drawing)

*Custom mounting flanges to accommodate different types of brakes can be supplied on request.*

### 7.0 - Bremsenflansch (gemäß Kundenzeichnung)

Auf Anfrage können die Getriebe so ausgelegt werden, dass unterschiedliche Bremstypen direkt am Getriebe montiert werden können.

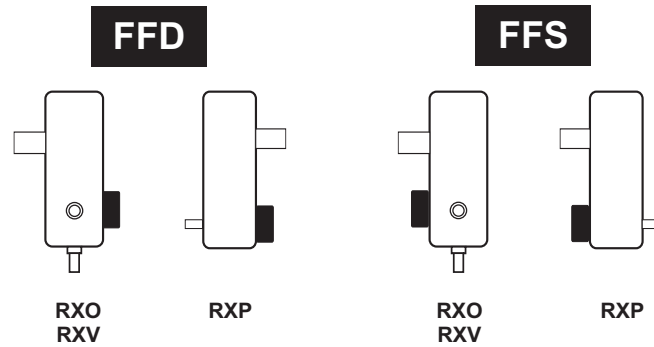





8.0 - Base porta motore

8.0 - Motor mount

8.0 - Motorauflage

**ACC9C**

**Accessori generali -  
Base motore**

**Accessories custom -  
Motor Mount**

**Zübehör custom -  
Motorbasis**

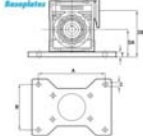
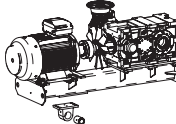
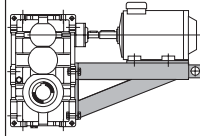
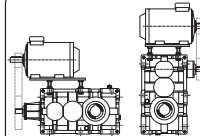
-	 <p><b>BM0</b></p>	 <p><b>BMPLATE</b></p>
 <p><b>BM1</b></p>		
 <p><b>BM2</b></p>		
 <p><b>BM3</b></p>		
<p><b>PMG - GEARBOX</b></p>		



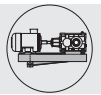

8.0 - Base porta motore

8.0 - Motor mount

8.0 - Motorauflage

8.1 - Applicabilità

8.1 - Application

8.1 - Applikation

	RXP	RXO	RXV
BM0 - Size IEC	to define - on request		
BM1 - Size IEC			
BM2 - Size IEC			
BM3 - Size IEC			

A richiesta sono disponibili 3 tipologie di basi porta motore. Nelle figure a seguito sono illustrate le forme costruttive delle 3 famiglie principali di questo prodotto. Nelle tipologie BM1 e BM2 sono fornibili come connessioni tra motore e riduttore giunti idrodinamici e giunti elastici, eventualmente equipaggiati con dischi a freno.

Three types of motor mounts are available on request. The diagrams below show three major families of motor mount products. On request, fluid and flexible couplings, also equipped with brake discs, are provided with types BM1 and BM2.

Auf Anfrage sind 3 Typologien von Motorauflagen verfügbar. Auf den folgenden Abbildungen werden die Bauformen der drei Hauptfamilien dieses Produkts illustriert. Die Typologien BM1 und BM2 können als Verbindungen zwischen Motor und Getriebe als hydrodynamische und elastische Kupplungen, eventuell mit Scheibenbremsen ausgestattet geliefert werden.

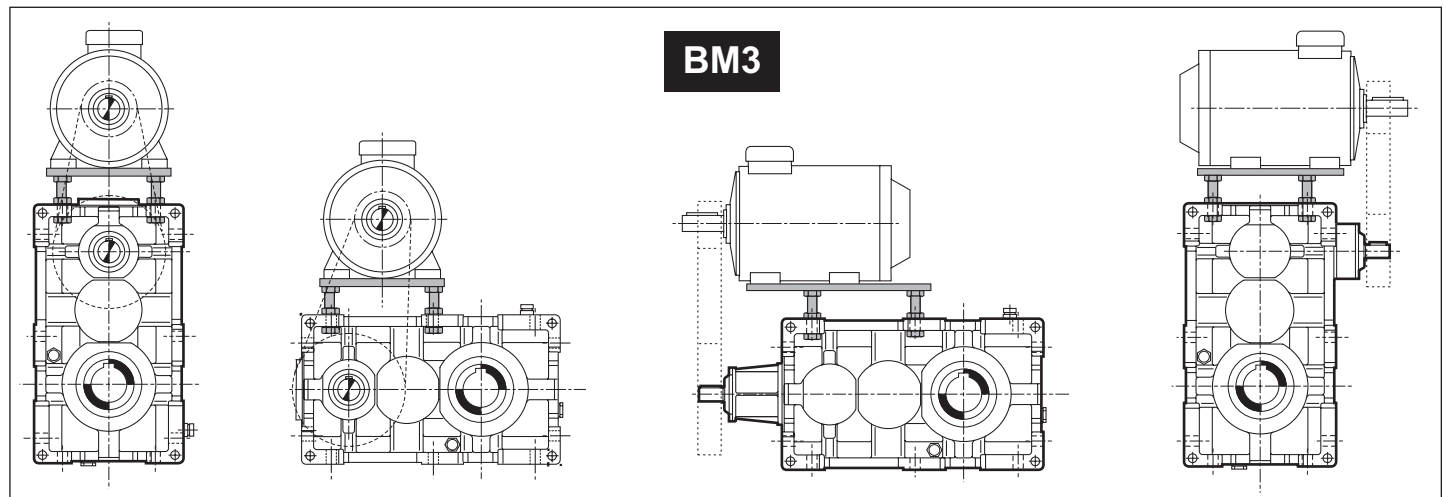
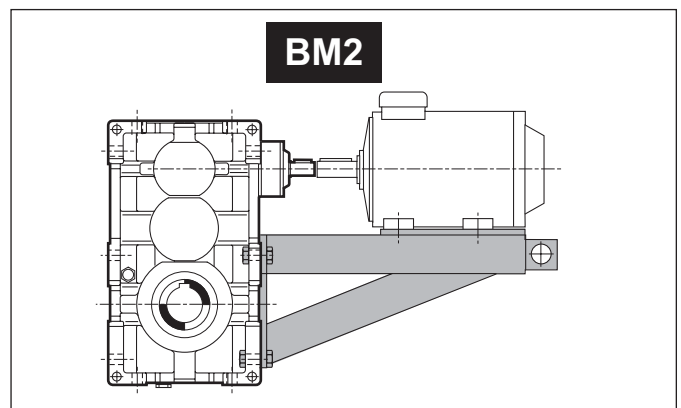
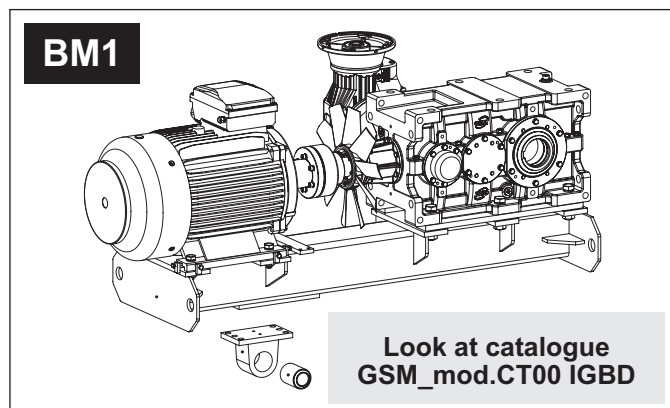

### Bussolle in VKL

A richiesta le basi di tipologia BM1 e BM2 sono equipaggiabili con bussolle in VKL. A seguito le dimensioni delle bussolle in corrispondenza alla taglia del riduttore.

### VKL bush

On request, motor mounts BM1 and BM2 can be equipped with VKL bushes. Bush dimensions for the different gear unit sizes are given in the table.

### VKL-Buchsen

Auf Anfrage können die Typologien BM1 und BM2 mit VKL-Buchsen ausgestattet werden. Nachstehend die für die Getriebegrößen passenden Buchsenmaße.

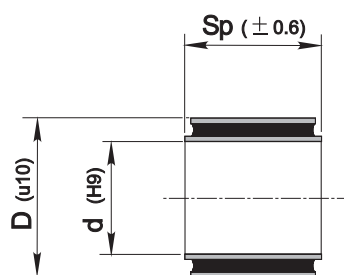

	D	d	Sp
808	65	40	88
810			
812	80	50	110
814			
816	140	100	120
818			
820	160	110	180
822			

**9.0 - ESTREMITÀ SUPPLEMENTARI**

**9.0 - ADDITIONAL SHAFT EXTENSIONS**

**9.0 - ZUSÄTZLICHE WELLENENDEN**

A richiesta è possibile fornire riduttori con estremità supplementari, in tali casi deve essere indicata la designazione dell'ES (estremità supplementare) come indicato in seguito.

On request, gear units are available with additional shaft extensions; please specify the designation of the required ES (additional shaft extension) as outlined below.

Auf Anfrage können die Getriebe mit zusätzlichen Wellenenden geliefert werden, in diesen Fällen muss wie folgt die Bezeichnung ES (steht für zusätzliches Wellenende) angegeben werden.

Designazione / Designation / Bezeichnung

RXO-RXV - [1] - [20] - Section B	RXO-RXV - [20]	RXO-RXV-[20a]	RXO-RXV-[20b]	RXO-RXV-[20c]	RXO-RXV-[20d]
RXP - [1] - [21] - Section A	RXP - [21]	RXP - [21a]	RXP - [21b]	RXP - [21c]	RXP - [21d]
	<b>ES</b>	<b>2</b>	<b>DX</b>	<b>506</b>	<b>PAM132</b>
	ES	1 - 2 - 3	DX - SX	Rapporto reale dall'estremità supplementare	ECE ECES PAM.. PAM..G

20	<b>ASE - Presenza di un'estremità supplementare</b>	<b>ASE - Additional shaft extension fitted</b>	<b>ASE - Ein zusätzliches Wellenende vorhanden</b>
21			

**ES**

20a	<b>AWASE - Asse dov' è presente l'estremità</b>	<b>AWASE - Axis where additional shaft extension is located</b>	<b>AWASE - Achse an der ein zusätzliches Wellenende vorhanden ist</b>
21a			

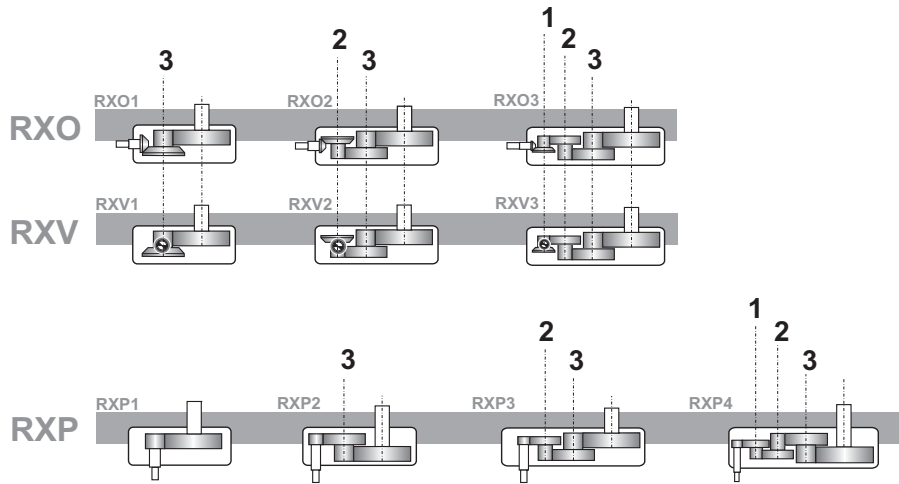

20b	<b>ASES - Lato estremità supplementare supplementare</b>	<b>ASES - Additional shaft extension side</b>	<b>ASES - Seite des zusätzlichen Wellenendes</b>
21b			

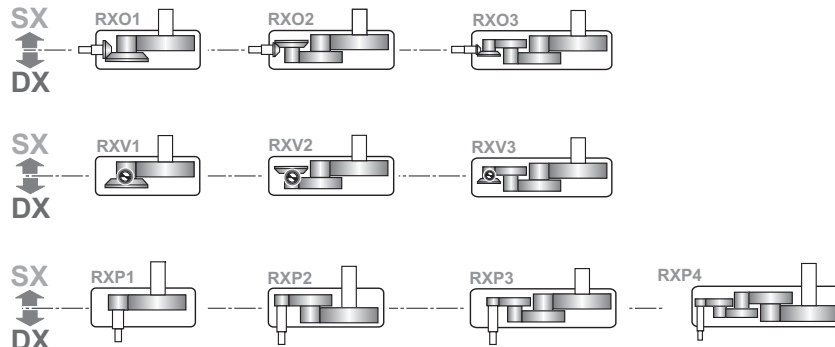

**9.0 - ESTREMITÀ SUPPLEMENTARI**

**9.0 - ADDITIONAL SHAFT EXTENSIONS**

**9.0 - ZUSÄTZLICHE WELLENENDEN**

**20c** IRASE - Rapporto reale del riduttore dalla estremità supplementare

*IRASE - Actual gear ratio of gear unit from additional shaft extension*

**IRASE - Reelles Übersetzungsverhältnis am zusätzlichen Wellenende**

Comunicato da GSM su richiesta.

*Information available from GSM on request.*

Gibt GSM auf Anfrage an.

**20d** ASET - Tipologia di estremità supplementare

**ASET - Additional shaft extension type**

**ASET - Typ des zusätzlichen Wellenendes**

**21d**

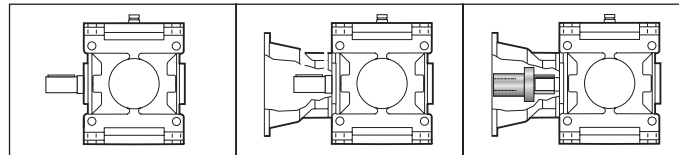

**ECE**

**PAM..**

**PAM..G**

<b>ECE</b>	Entrata con albero pieno	<i>Solid input shaft</i>	Antrieb mit Vollwelle
<b>ECES</b>	Entrata con estremità speciale (disponibile a richiesta)	<i>Special input shaft end (available on request)</i>	Antrieb mit speziellem Wellenende (auf Anfrage verfügbar)
<b>PAM..</b>	Con campana senza giunto	<i>Motor bell without coupling</i>	Mit Glocke ohne Kupplung
<b>PAM..G</b>	Con campana e giunto	<i>Motor bell and coupling</i>	Mit Glocke und Kupplung

**Dimensioni**

**Dimensions**

**Applizierbare Motoren**

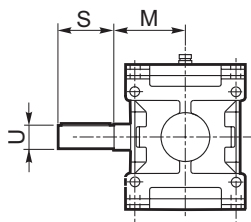

Grandezza Size Größe	Tipo Type Typ	Asse / Axis / Achse								
		1			2			3		
		U	S	M	U	S	M	U	S	M
802	RXO1-RXV1	—	—	—	—	—	—	35 k6	63	137
	RXP2	—	—	—	—	—	—	35 k6	63	109
	RXO2-RXV2-RXP3	—	—	—	28 j6	50	109	35 k6	63	109
	RXO3-RXV3-RXP4	22 j6	40	109	28 j6	50	109	35 k6	63	109
804	RXO1-RXV1	—	—	—	—	—	—	40 k6	70	151
	RXP2	—	—	—	—	—	—	40 k6	70	121
	RXO2-RXV2-RXP3	—	—	—	32 k6	56	121	40 k6	70	121
	RXO3-RXV3-RXP4	24 j6	45	121	32 k6	56	121	40 k6	70	121
806	RXO1-RXV1	—	—	—	—	—	—	45 k6	80	170
	RXP2	—	—	—	—	—	—	45 k6	80	137
	RXO2-RXV2-RXP3	—	—	—	35 k6	63	137	45 k6	80	137
	RXO3-RXV3-RXP4	28 j6	50	137	35 k6	63	137	45 k6	80	137
808	RXO1-RXV1	—	—	—	—	—	—	50 k6	90	192
	RXP2	—	—	—	—	—	—	50 k6	90	151
	RXO2-RXV2-RXP3	—	—	—	40 k6	70	151	50 k6	90	151
	RXO3-RXV3-RXP4	32 k6	56	151	40 k6	70	151	50 k6	90	151
810	RXO1-RXV1	—	—	—	—	—	—	55 m6	100	216
	RXP2	—	—	—	—	—	—	55 m6	100	170
	RXO2-RXV2-RXP3	—	—	—	45 k6	80	170	55 m6	100	170
	RXO3-RXV3-RXP4	35 k6	63	170	45 k6	80	170	55 m6	100	170
812	RXO1-RXV1	—	—	—	—	—	—	60 m6	112	242
	RXP2	—	—	—	—	—	—	60 m6	112	192
	RXO2-RXV2-RXP3	—	—	—	50 k6	90	192	60 m6	112	192
	RXO3-RXV3-RXP4	40 k6	70	192	50 k6	90	192	60 m6	112	192
814	RXO1-RXV1	—	—	—	—	—	—	70 m6	125	273
	RXP2	—	—	—	—	—	—	70 m6	125	216
	RXO2-RXV2-RXP3	—	—	—	55 m6	100	216	70 m6	125	216
	RXO3-RXV3-RXP4	45 k6	80	216	55 m6	100	216	70 m6	125	216
816	RXO1-RXV1	—	—	—	—	—	—	80 m6	140	302
	RXP2	—	—	—	—	—	—	80 m6	140	242
	RXO2-RXV2-RXP3	—	—	—	60 m6	112	242	80 m6	140	242
	RXO3-RXV3-RXP4	50 k6	90	242	60 m6	112	242	80 m6	140	242
818	RXO1-RXV1	—	—	—	—	—	—	90 m6	160	273
	RXP2	—	—	—	—	—	—	90 m6	160	273
	RXO2-RXV2-RXP3	—	—	—	70 m6	125	273	90 m6	160	273
	RXO3-RXV3-RXP4	55 m6	100	273	70 m6	125	273	90 m6	160	273
820	RXO1-RXV1	—	—	—	—	—	—	100 m6	180	302
	RXP2	—	—	—	—	—	—	100 m6	180	302
	RXO2-RXV2-RXP3	—	—	—	80 m6	140	302	100 m6	180	302
	RXO3-RXV3-RXP4	60 m6	112	302	80 m6	140	302	100 m6	180	302

9.0 - ESTREMITÀ SUPPLEMENTARI

9.0 - ADDITIONAL SHAFT EXTENSIONS

9.0 - ZUSÄTZLICHE WELLENENDEN

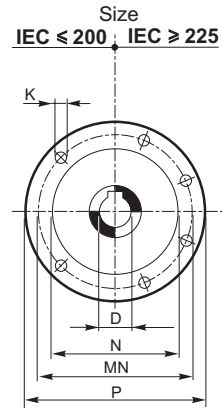
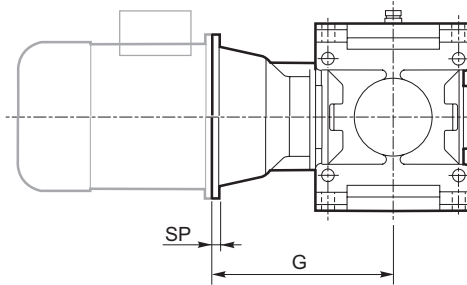
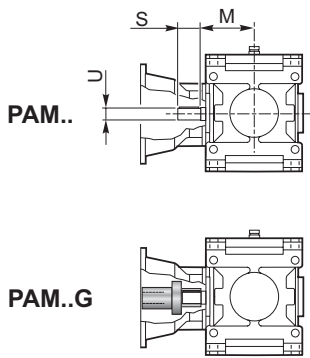

Asse / Axis / Achse 1

		IEC												
		80	90	100	112	132	160	180	200	225	250	280	315	355
D H7		19	24	28	28	38	42	48	55	60	65	75	80	100
P		200	200	250	250	300	350	350	400	450	550	550	660	800
MN		165	165	215	215	265	300	300	350	400	500	500	600	740
N G6		130	130	180	180	230	250	250	300	350	450	450	550	680
K		M10	M10	M12	M12	M12	M16	M16	M16	M16	M16	M16	M16	M20
SP		12	12	14	14	16	18	18	20	20	20	20	24	30
G	802		203	213	213	233	263	263	263					
	804			230	230	250	280	280	280	310				
	806			251	251	271	301	301	301	331				
	808			271	271	291	321	321	321	351	351	351		
	810					317	347	347	347	377	377	377	407	
	812					346	376	376	376	406	406	406	436	
	814						410	410	410	440	440	440	470	
	816						446	446	446	476	476	476	506	546
	818								487	517	517	517	547	587
820									558	558	558	588	628	

Asse / Axis / Achse 2

		IEC												
		80	90	100	112	132	160	180	200	225	250	280	315	355
D H7		19	24	28	28	38	42	48	55	60	65	75	80	100
P		200	200	250	250	300	350	350	400	450	550	550	660	800
MN		165	165	215	215	265	300	300	350	400	500	500	600	740
N G6		130	130	180	180	230	250	250	300	350	450	450	550	680
K		M10	M10	M12	M12	M12	M16	M16	M16	M16	M16	M16	M16	M20
SP		12	12	14	14	16	18	18	20	20	20	20	24	30
G	802				223	243	273	273	273					
	804						291	291	291	321				
	806						314	314	314	344				
	808						335	335	335	365	365	365		
	810								364	394	394	394		
	812									426	426	426	456	
	814									460	460	460	490	530
	816										498	498	528	568
	818										542	542	572	612
820												616	656	

Le altre dimensioni dei riduttori potranno essere reperite nelle corrispondenti sezioni RXP e RXO.

For gear unit dimensions not covered here, please see the relevant RXP and RXO sections.

Die weiteren Abmessungen der Getriebe können den jeweiligen Abschnitten RXP und RXO entnommen werden.

**10.0 - CAMBI DI VELOCITÀ**

A richiesta è possibile fornire riduttori con cambio di velocità, in tali casi, nelle designazioni dei riduttori RXP e RXO riportate nelle rispettive sezioni, in corrispondenza di ir (colonna [IR] deve essere riportato 2V, 3V, ... (numero di marce desiderato e rapporto reale delle rispettive marce) come indicato in seguito.

I riduttori con cambio di velocità presentano un gioco angolare in inversione di moto di diversi gradi angolari. Il gioco angolare è dovuto al profilo speciale a coda di rondine che GSM utilizza nella trasmissione del moto tra innesto e ingranaggio.

Nelle applicazioni con cicli ad inversione del moto nelle quali il gioco angolare richiesto sia inferiore a 20' contattare il nostro Servizio Tecnico.

**10.0 - GEAR SHIFT**

*Gear-shift drives are available on request; when designating RXP and RXO gear units as outlined in the relevant sections, specify number of speeds and actual gear ratios (2V, 3V, ...) under item ir (column [IR]) as outlined below.*

*The shift gearboxes have a backlash on reversal of angular motion of different degrees. The backlash is due to the special profile dovetail which uses GSM in the transmission of motion between the selector and gear.*

*In applications with inversion of cycles in which the backlash required is less than 20', please to contact our Technical Service*

**10.0 - SCHALTGETRIEBE**

Auf Anfrage können Schaltgetriebe geliefert werden, in diesen Fällen muss unter den Bezeichnungen der RXP- und der RXO-Getriebe in den jeweiligen Abschnitten, unter der Angabe ir (Spalte [IR]) 2V, 3V, ... angegeben werden (Anzahl der gewünschten Gänge und reelles Übersetzungsverhältnis der Gänge); siehe nachstehende Angaben.

Die Wechselgetriebe verfügen über einen Umkehr-Winkelspielraum verschiedener Winkelgrade.

Der Winkelspielraum basiert auf dem speziellen Schwalbenschwanzprofil, das die GSM bei der Bewegungsübertragung zwischen der Kupplung und dem Getriebe nutzt.

Bei Anwendungen mit Umkehrzyklen bei denen der erforderliche Winkelspielraum unter 20' liegt, setzen Sie sich bitte mit unserem Kundendienst in Verbindung

Designazione / Designation / Bezeichnung

	IR		
	2V		
	2V-"ir"-"ir" 3V-"ir"-"ir"-"ir" ...		

Esempio / Example / Beispiel

**RXP2/814/2V-7-14/ECES/N/M1**

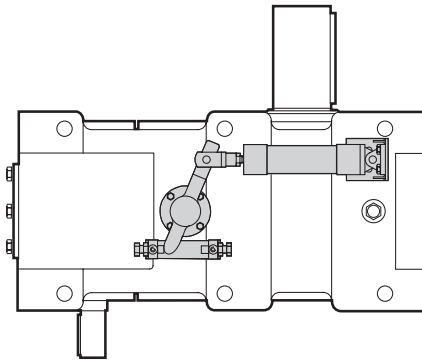
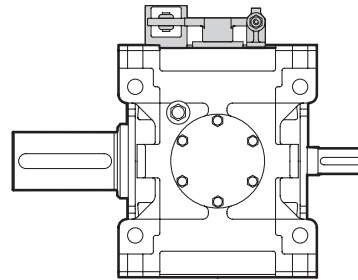
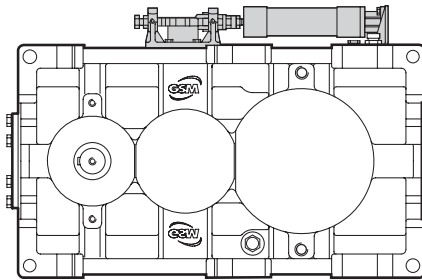

Per configurazioni disponibili, prestazioni e dimensioni contattare il servizio tecnico commerciale GSM.

*Please contact GSM Sales Engineers for detailed information on available configurations, ratings and dimensions.*

Die verfügbaren Konfigurationen, Leistungen und Abmessungen können in der Technischen Abteilung der STM angefragt werden.



Gestione Revisioni Cataloghi GSM  
*Managing GSM Catalog Revisions*  
Management Wiederholt Kataloge GSM



**Gestione Revisioni Cataloghi GSM**

**Managing GSM Catalog Revisions**

**Management Wiederholt Kataloge GSM**

**Codice Catalogo**

**Catalog Code**

**Katalogcode**

	<b>GSM_mod.CT05</b>	<b>I</b>	<b>GB</b>	<b>D</b>	<b>1.0</b>		
	N° Identificativo <i>Identification Number</i> Kennnummer	Identificativo Lingua - <i>Language</i> - Sprache  <b>I</b> - Italiano – <i>Italian</i> - Italienisch <b>GB</b> – Inglese – <i>English</i> - Englisch <b>D</b> – Tedesco – <i>German</i> - Deutsch				Indice di Revisione <i>Review</i> Bericht	

1) Ogni catalogo GSM in distribuzione e' provvisto di un codice che lo identifica che è riportato nell'ultima pagina dei cataloghi e a piè pagina di tutte le pagine del catalogo stesso. Per verificare la revisione attualmente in vostro possesso è necessario guardare l'ultima cifra che compone il codice del catalogo:

*1) Each GSM catalogue is identified by a code printed on the last page and reported in the page footer. The last digit in the catalogue code identifies catalogue revision:*

1) Jeder, sich im Umlauf befindliche GSM-Katalog ist mit einer Identifikationsnummer versehen, der auf der letzten Seite und in den Fußnoten jeder einzelnen Seite aufgeführt ist. Um zu überprüfen, über welche Revision Sie im Augenblick verfügen, müssen Sie Bezug auf die letzte Ziffer der Katalogkennnummer nehmen.

2) Il catalogo che contiene gli ultimi aggiornamenti è reperibile sul sito internet STM. Le modifiche riportate sono visibili consultando la tabella degli aggiornamenti che è allegata a questo documento. Sulle pagine che sono oggetto della modifica è riportato l'indice di revisione cambiato.



*2) Latest updated catalogues are available on STM's web site. Changes are listed in the updates table attached to this document. Any pages including a change are identified by a higher revision number.*

2) Der Katalog, der die letzten Aktualisierungen enthält, kann von der Internetseite der STM herunter geladen werden. Die eingefügten Neuerungen können der Tabelle der Aktualisierungen entnommen werden, die diesem Dokument anhängt. Die Seiten, die Änderungen unterlagen, sind mit der geänderten Revisionsnummer versehen.

3) Guardare con attenzione il simbolo inserito nella colonna "Classificazione Modifica". In questa colonna sarà inserito un simbolo che determina una classificazione delle modifiche apportate. Questo consente di identificare con estrema rapidità l'importanza della modifica apportata;

*3) Pay attention to the symbol in the "Change Classification" column. This symbol signifies the category and significance of any changes*

3) Besonders auf das in die Spalte „Änderungsklasse“ eingefügte Symbol achten. In dieser Spalte wird das Symbol eingefügt, das für die Klasse der applizierten Änderungen steht.

<b>Classificazione Classification Klasse</b>	<b>Definizione Specificante gli elementi di modifica Definition Change identifier Erklärende Definition der Änderungselemente</b>	<b>Simbolo Identificativo Symbol Identifikationssymbol</b>
Chiave <i>Key</i> Schlüssel	Uscita e immissione di un prodotto <i>Product issuance and marketing</i> Ausgabe und Einführung eines Produkts	
Importante <i>Major</i> Wichtig	Modifica che influenza gli ingombri/stato fornitura/installazione del prodotto <i>Change affecting overall dimensions/delivery condition/product installation</i> Änderung, die sich auf die Abmessungen/Lieferzustand/Produktinstallation auswirkt	
Secondaria <i>Minor</i> Sekundär	Modifica che riguarda traduzioni/impaginazioni/inserimento descrizioni <i>Change to translations/layout/captions</i> Änderung, die Übersetzungen/den Umbruch/eingefügte Beschreibungen betrifft	—

4) Qualora risultasse una diversità di quote tra disegno **2D** – **3D** scaricato dal sito internet e tabella del catalogo è necessario consultare il nostro servizio tecnico.

*4) In the event the dimensions in the 2D – 3D drawing downloaded from our site differ from those indicated in the catalogue table, contact our Engineering.*

4) Diese ermöglicht ein schnelles Erfassen der Wichtigkeit der angesetzten Änderung.

Attenzione  
Verificare la revisione in vostro possesso e la tabella degli aggiornamenti apportati nella nuova revisione.

*Warning  
Check your catalogue revision status against the latest updates table.*

Achtung  
Überprüfen Sie die Revision, die sich in Ihren Händen befindet, und die Tabelle der in der neuen Revision eingefügten Aktualisierung.

			Aggiornamenti apportati Updates made				
Codice Code	Indice Revisione Index – Updates OLD	Sezione N° Section N°	Pagina Page OLD	Descrizione Description	Indice Revisione Index – Updates NEW	Pagina Page NEW	Classificazione Modifica Update classification



**Potenza richiesta / Required power / Benötigte Leistung**

$$P = \frac{m \cdot g \cdot v}{6 \cdot 10^4}$$

Sollevamento  
*Lifting*  
Heben

$$P = \frac{M \cdot n}{9550}$$

Rotazione  
*Rotation*  
Drehung

$$P = \frac{F \cdot v}{6 \cdot 10^4}$$

Traslazione  
*Linear movement*  
Linearbewegung

$$M = \frac{9550 \cdot P}{n}$$

Coppia  
*Torque*  
Drehmoment

$$F = 1000 \cdot \frac{M}{r}$$

Forza  
*Force*  
Kraft

$$v = \frac{2r \cdot \pi \cdot n}{1000}$$

Velocità lineare  
*Linear speed*  
Lineargeschwindigkeit

**Carichi radiali / Radial load / Radialkräfte**

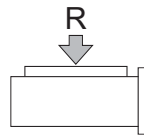

$$R = \frac{2000 \cdot T \cdot Kr}{d}$$

**R (N)**  
Carico radiale  
*Radial load*  
Radialkraft

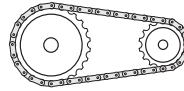

$$Kr = 1$$

Ruota per catena  
*Chain-wheel*  
Kettenrad

**T (Nm)**  
Coppia sull'albero  
*Torque*  
Drehmoment

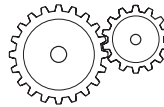

$$Kr = 1.06$$

Ingranaggio  
*Gear*  
Zahnrad

**d (mm)**  
Diametro della ruota  
*Diameter*  
Durchmesser

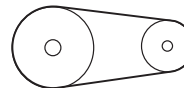

$$Kr = 1.5-2.5-3.5$$

1.5 - Cinghie dentate/Toothed belts/Zahnriemen

2.5 - Cinghie trapezoidali/V belt drives/Keilriemen

3.5 - Ruote di frizione (gomma su metallo)  
*Friction wheel drive (rubber on metal)*  
Kupplungsräder (Gummi auf Metall)

**Momento d'inerzia**

**Moment of inertia**

**Trägheitsmoment**

$$J = 98 \cdot p \cdot l \cdot D^4$$

Cilindro pieno / *Solid cylinder* / Vollzylinder

$$J = 98 \cdot p \cdot l \cdot (D^4 - d^4)$$

Cilindro cavo / *Hollow cylinder* / Hohlzylinder

Conversione di una massa in movimento lineare in un momento d'inerzia riferito all'albero del motore

*Conversion of a mass having a linear movement into a moment of inertia related to the motor shaft.*

Umwandlung einer Masse mit Linearbewegung in ein Trägheitsmoment, das auf die Motorwelle bezogen ist.

$$J = 91.2 \cdot m \cdot \frac{v^2}{n^2}$$

Conversione di diversi momenti d'inerzia di massa a velocità diverse in un momento d'inerzia riferito all'albero motore.

*Conversion of various mass moments of inertia having different speeds into a moment of inertia related to the motor shaft.*

Umwandlung von verschiedenen Trägheitsmomenten mit unterschiedlichen Geschwindigkeiten in ein Trägheitsmoment, das auf die Motorwelle bezogen ist.

$$J_a = \frac{J_2 \cdot n_2^2 + J_3 \cdot n_3^2 \dots}{n_1^2}$$

P	= Potenza motore	<i>Rated power</i>	Motorleistung	[kW]
m	= Massa	<i>Mass</i>	Masse	[kg]
v	= Velocità lineare	<i>Linear speed</i>	Lineargeschwindigkeit	[m/min]
F	= Forza	<i>Force</i>	Kraft	[N]
n	= Velocità di rotaz.	<i>Rotation speed</i>	Drehzahl	[min <sup>-1</sup> ]
g	= 9.81	<i>9.81</i>	9.81	[m/sec]
M	= Coppia del motore	<i>Motor torque</i>	Motor-Drehmoment	[Nm]
r	= Raggio	<i>Radius</i>	Radius	[mm]
J	= Inerzia	<i>Moment of inertia</i>	Trägheitsmoment	[kgm <sup>2</sup> ]
l	= Lunghezza	<i>Length</i>	Länge	[mm]
d	= Diametro interno	<i>Inner diameter</i>	Innendurchmesser	[mm]
D	= Diametro esterno	<i>Outer diameter</i>	Außendurchmesser	[mm]
p	= Peso specifico	<i>Specific weight</i>	Spezifisches Gewicht	[kg/dm <sup>3</sup> ]



**High Tech line**  
**GSM\_mod.CT 05 IGBD1.0**  
**02/22**

Questo catalogo annulla e sostituisce ogni precedente edizione o revisione.

I dati esposti nel catalogo non sono impegnativi e ci riserviamo il diritto di apportare eventuali modifiche senza darne preavviso, nell'ottica di un miglioramento continuo del prodotto.

Qualora questo catalogo non Vi sia giunto in distribuzione controllata, l'aggiornamento dei dati ivi contenuto non è assicurato.

**In tal caso la versione più aggiornata è disponibile sul ns. sito internet:  
[www.stmspa.com](http://www.stmspa.com)**

*This catalogue cancels and replaces any preceding issue or revision.*

*The data provided in the catalogue are not binding; in line with our commitment to on-going product improvement, we reserve the right to make changes without prior notice.*

*If you obtained this catalogue other than through controlled distribution channels, no warranty is made as to whether the data contained herein is up-to-date.*

***When in doubt, you are welcome to download the latest up-to-date version available on our web site:  
[www.stmspa.com](http://www.stmspa.com)***

Dieser Katalog annulliert und ersetzt jede vorausgehende Ausgabe oder Revision.

Die im vorliegenden Katalog enthaltenen Daten sind nicht verpflichtend. Wir behalten uns diesbezüglich das Recht vor, ohne entsprechende Vorankündigungen und im Sinne einer kontinuierlichen Produktverbesserung eventuelle Änderungen antragen zu können.

Sollten Sie diesen Katalog nicht im Zuge eines kontrollierten Vertriebs erhalten haben, kann die Aktualisierung der darin enthaltenen Daten nicht gewährleistet werden.

**In diesem Fall finden Sie die aktuellste Version unter der Website:  
[www.stmspa.com](http://www.stmspa.com)**



[chainanddrives.com.au](http://chainanddrives.com.au)  
[support@chainanddrives.com.au](mailto:support@chainanddrives.com.au)