

CYCLO[®] HBB HELICAL BUDDYBOX[®]

Gearmotor and Speed Reducers

DISTRIBUTED BY



CHAIN & DRIVES[®]
COMPLETE BEARINGS
& POWER TRANSMISSION

SERVICE & SUPPORT

Wangara, WA	Welshpool, WA	Arndell Park, NSW
+61 8 9303 4966	+61 8 6314 1155	+61 2 9674 8611
support@chainanddrives.com.au	salesnsw@chainanddrives.com.au	

chainanddrives.com.au



EPNA Motors

Enhanced Performance (EPNA) integral motors represent exceptional value to customers. To maximize the performance of the motors, a host of advanced features has been developed providing tangible benefits to the users.

All in one

To simplify transactions throughout the continent, North American version (.NA) features standard multiple listings including DOE, UL and CSA, along with CE marking. Other versions are available for premium performance with European 50 Hz voltages.

Exceptionally long life

Our Premium Efficient Motors feature lower temperature rise and robust class "F" insulation. The combination of those attributes yield reduced motor operating temperatures that exponentially increase the thermal life of the insulation. In order to match the longer insulation life, deep groove ball bearings have been incorporated to further extend the life of our products.

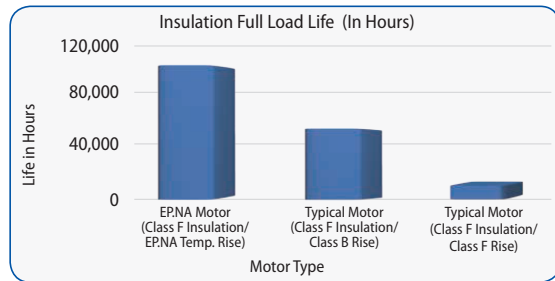

Eco friendly

Premium efficiency, mandated by the DOE (Department of Energy, USA), shrinks the carbon footprint by delivering more torque at the same level of energy consumption. Higher starting torques may allow smaller motors to be selected for some applications.

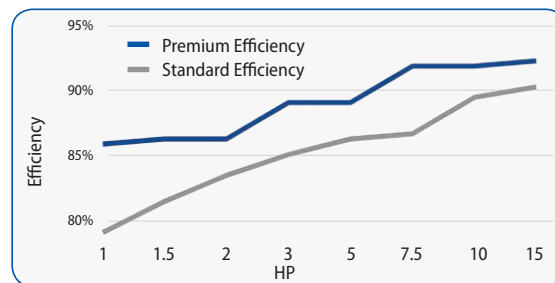

Cost-effective

The premium efficiency design is cost-effective in reducing energy consumption throughout the full speed range, resulting in a lower total lifecycle cost.

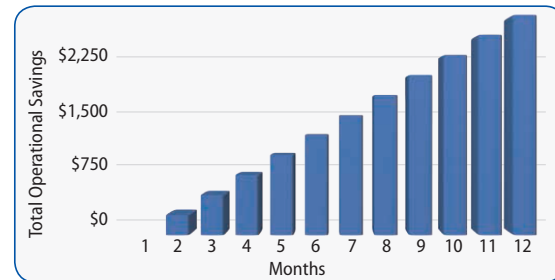

The assumptions for the study are as follows:
 9.8 cents of a dollar per kWh • 8600 operating hours annually • A 7.5 kilowatt motor (10 HP) • IE3 motor costing 25% more than the IE1 motor • IE3 premium efficiency motor being 2.8% more efficient than the IE1 standard efficiency motor

Inverter duty

All of the motors feature corona resistant magnet wire that resists the voltage spikes that are inherent to the widely applied IGBT inverters and extends insulation life. Inverter duty brake motors are also available. The non-brake motors are suitable for a 10:1 turndown. The advanced fan design helps to keep the motor running cool at lower input speeds.

Optimized Geometry

Increasing motor size is one of several techniques to reduce losses and achieve premium efficiency. Sumitomo optimized its existing external envelope while still accommodating a large motor core. The result is a compact premium efficient motor.

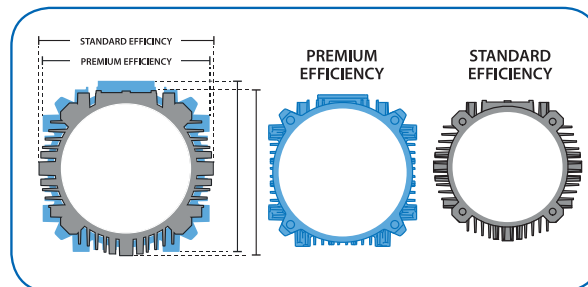

For applications ranging from robotics to bulk material handling.

Sumitomo offers a comprehensive lineup of premier power transmission products to keep customers' operations performing at their best. This includes the broadest range of the most reliable and highest quality speed reducers, gearmotors and large industrial gearboxes available in the industry.

	Torque (lbs-in)	8.85	88.5	885	8,850	88,507	885,075	8,850,746
Precision / Motion Control	IB P1 Series		71 - 1,354 lb-in (8 - 153 N-m)					
	Servo 6000		142 - 4,425 lb-in (16 - 500 N-m)					
	Fine Cyclo®			1,318 - 45,492 lb-in (149 - 5,140 N-m)				
Inline	Cyclo® 6000		55 - 603,000 lb-in (6.2 - 68,130 N-m)					
Right Angle	Hyponic®		44 - 13,100 lb-in (5 - 1,480 N-m)					
	Cyclo® BBB 5 Series			1,088 - 45,450 lb-in (123 - 5,140 N-m)				
	Cyclo® BBB 4 Series			1,088 - 159,983 lb-in (123 - 17,400 N-m)				
Offset Parallel	Cyclo® HBB			1,080 - 75,800 lb-in (122 - 8,564 N-m)				
	Helical Shaft Mount			3,900 - 388,884 lb-in (440 - 43,938 N-m)				
Large Industrial	Paramax® 9000			23,012 - 4,885,614 lb-in (2,600 - 552,000 N-m)				
	Hansen P4 Single-Stage			40,000 - 1,504,000 lb-in (4,519 - 170,000 N-m)				
	Hansen P4 Multi-Stage			46,000 - 9,735,825 lb-in (5,200 - 1,100,000 N-m)				
	Hansen P4 Vertical			105,000 - 7,250,000 lb-in (11,863 - 819,000 N-m)				
	Hansen P4 UniMiner			122,000 - 889,000 lb-in (13,784 - 100,445 N-m)				
	Seisa Drives			DP1000: 40,713 - 6,515,000 lb-in (4,600 - 736,000 N-m) Mill Drives: 7,806,362 - 42,625,212 lb-in (882,000 - 4,816,000 N-m)				
	Torque (N-m)	1	10	100	1,000	10,000	100,000	1,000,000



Product Configurator: www.sumitomodrive.com/Configurator

Sumitomo Drive Technologies' online product Configurator streamlines the selection process, enabling you to build **our power transmission products for your specific application.**

Configure your Sumitomo Drive Technologies products today at www.sumitomodrive.com/Configurator

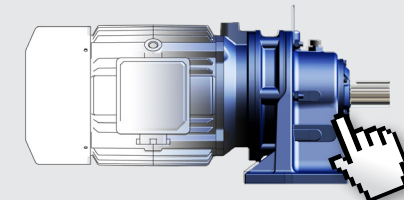

Scan with a QR code reader to login!

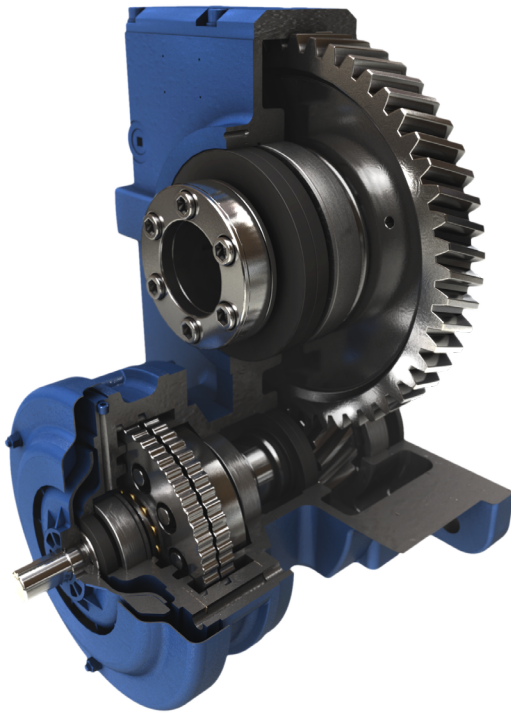

Table of Contents

1. General Information

2. Speed Reducers

How to Select	2.2
Configure a Model Number (Nomenclature) . . .	2.4
AGMA Load Classifications.	2.6
Selection Tables	2.8
Single Reduction	2.8
Double Reduction	2.12
Dimensions	2.14
C-Face Single Reduction	2.14
C- Face Double Reduction	2.16
Quill Single Reduction	2.19
Quill Double Reduction	2.20

3. Gearmotors

How to Select	3.2
Configure a Model Number (Nomenclature)	3.4
AGMA Load Classifications	3.6
Selection Tables	3.10
Single Reduction	3.10
Double Reduction	3.62
Dimensions	3.80

4. Options

Keyed Hollow Shaft	4.2
Output Flange	4.2
Torque Arm "T" Type	4.4
Torque Arm Clevis Type	4.4
Screw Conveyor Drive	4.5
Industry Packages	4.6

5. Technical Information

Exact Ratios	5.2
Special Load Guidelines	5.7
Lubrication	5.11
Motor	5.15
Standard Wiring	5.28
Brakemotor	5.31
Brakemotor Wiring	5.36
Warranty	5.42

► Flexible configurations

• Mounting Options:

- Flange
- Face
- Torque Arm
- Screw Conveyor

Patented universal housing design

Double output seals prevent lubricant leaks and protect from contamination

Patented keyless, steel Taper-Grip[®] bushing allows for quick and easy mounting and removal. Installs from either side

Utilizes all Cyclo[®] input modifications: C-Face input, integral gearmotor, brakemotor or servomotor

Cyclo[®] input provides high overload capacity, exceptional reliability and long service life

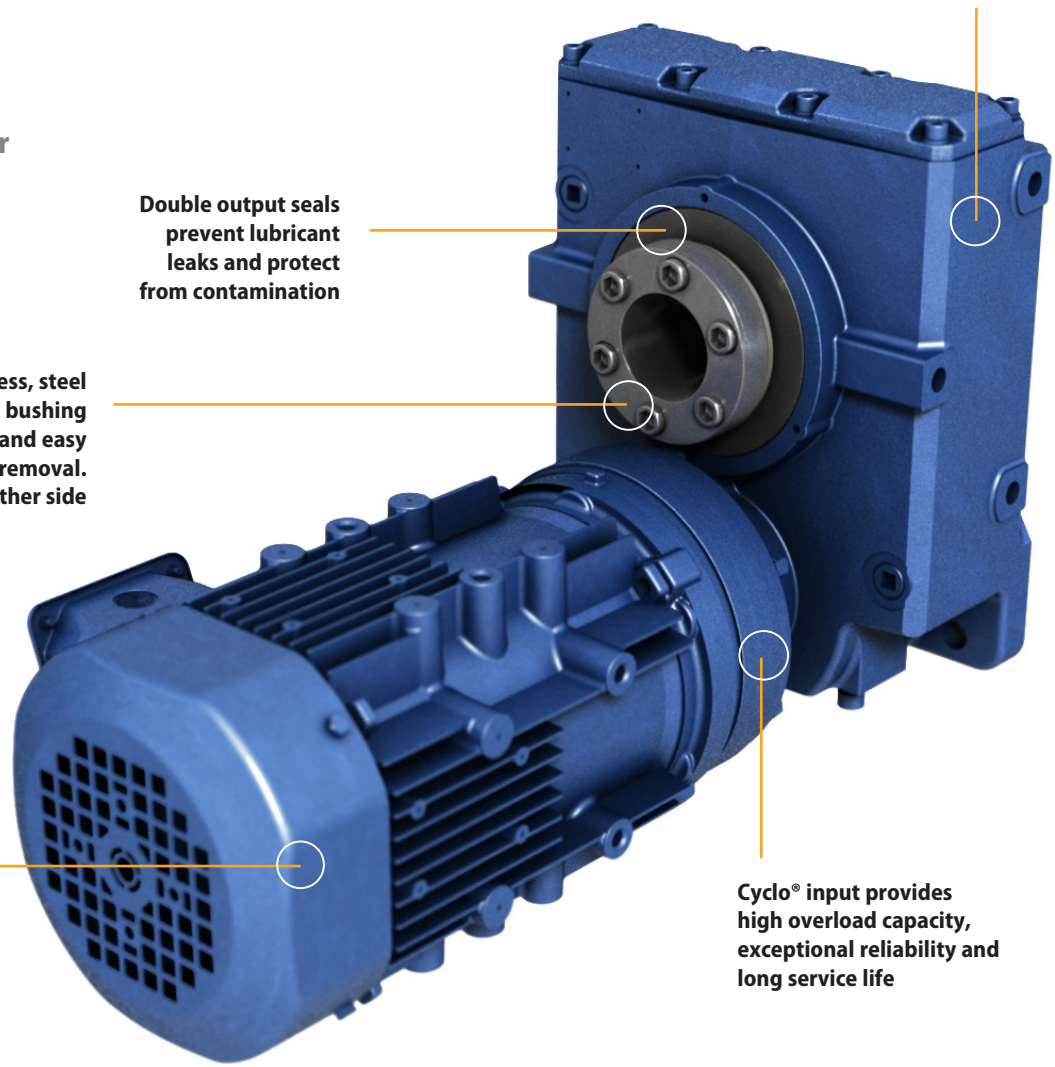

Cyclo[®] Quality and Reliability, Shaft Mount Design

► High performance steel gearing components deliver **up to 95% efficiency**



Product Description

Sumitomo's Cyclo® Helical Buddybox (Cyclo® HBB) speed reducers and gearmotors provide **innovative shaft mounted drive solutions for demanding services**. The Cyclo® HBB combines the quiet, efficient and reliable performance of the Cyclo® technology input with the **rugged helical gear output**. The **modular design** provides a compact, efficient product and the most flexible range of output speed and torque combinations available. Sumitomo's patented Taper Grip® bushing system enhances the Cyclo® HBB value by offering a simple shaft-mounting device that provides **self-aligning, backlash-free torque transmission** to the driven shaft. The Cyclo® HBB design is flexible and easily adapts to CEMA Screw Conveyor Drive applications with a modular conversion kit.

Features & Benefits

- **Cycloidal speed reduction technology**
 - ~ Quiet, efficient and reliable operation with high torque density and compact size
- **Modular design**
 - ~ Interchangeable cast iron housings in foot, flanged or face mount configurations
- **Double output seals**
 - ~ Virtually leak-free operation and optimal protection from lubrication contamination
- **Taper Grip® Bushing**
 - ~ Simple, steel, keyless shaft mounting system resists fretting and eases unit installation and removal from driven shaft
- **CEMA Screw Conveyor Drive option**
 - ~ Quick and simple conversion for Cyclo® HBB units to fit CEMA standard dimensions

Specifications

Ratios:	11:1 up to 26,000:1 and greater
Torque Capacity:	Up to 75,800 in. lbs.
HP:	1/8 to 40
Mounting:	Hollow Shaft, Flange, Face
Options:	Integral Motor, C-Face, Quill
Motor Standards:	NEMA, IEC, JIS, UL, CSA, CE

► Keyless, steel Taper-Grip® bushing makes mounting of hollow shaft units easy and economical

The Sumitomo **Taper-Grip®** bushing is a keyless, torque transmission device integrated into the shaft mounted, offset parallel Cyclo® HBB reducer and gearmotor product lines.

The **unique, patented design** has a number of benefits :

- Easy mounting and removal of the unit to and from the driven shaft
- Standard bore sizes require no shaft preparation such as a keyway, undercut, or keeper plate
- Backlash free torque transmission
- Works with standard shafting, no special tolerances required
- Automatic shaft center alignment
- Resistant to fretting corrosion
- Multiple stock bore sizes for quick delivery.

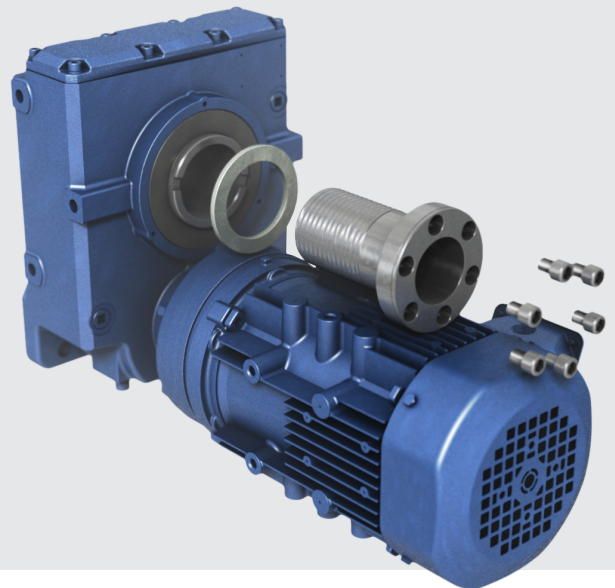

► Applications

- Material Handling
- Conveyors
- Baggage Handling
- Shredders
- Belt Filter Press
- Mixer/Blender
- Rolling Mill Table
- Screw Conveyors
- Elevators
- Hoist Drives
- Climber Screens
- Food Processing

Product Range (Standard Motor and Reducer Combinations)

Reduction Ratios 11 - 417 Combinations with 1450 and 1750 RPM motor

Input Type	Planetary		Cyclo																			
	Nominal Ratio	Actual Ratio	11	18	21	28	39	46	53	60	74	88	102	123	151	179	207	249	305	417		
Actual Output RPM	1450	50 Hz	*	*	21.0	28.0	38.5	45.5	52.5	59.5	73.5	87.5	101.5	122.5	150.5	178.5	206.5	248.5	304.5	416.5		
	1750	60 Hz	*	*	83.3	62.5	45.5	38.5	33.3	29.4	23.8	20.0	17.2	14.3	11.6	9.80	8.47	7.04	5.75	4.20		
Motor Power HP (kW)	1/8 (0.1)																					
	1/4 (0.2)																					
	1/3 (0.25)																					
	1/2 (0.4)																					
	3/4 (0.55)																					
	1 (0.75)																					
	1.5 (1.1)																					
	2 (1.5)																					
	3 (2.2)																					
	5 (3.7)																					
	7.5 (5.5)																					
	10 (7.5)																					
	15 (11)																					
	20 (15)																					
	25 (18.5)																					
	30 (22)																					
	40 (30)																					

* Refer to the table shown at the bottom of this page

Reduction Ratios 364 - 10658 Combinations with 1450 and 1750 RPM motor

Input Type	Cyclo																	
	Nominal Ratio	Actual Ratio	364	424	501	578	683	809	956	1117	1320	1656	1957	2272	2559	2944	3511	4365
Actual Output RPM	1450	50 Hz	3.98	3.42	2.90	2.51	2.12	1.79	1.52	1.30	1.10	0.876	0.741	0.638	0.567	0.493	0.413	0.332
	1750	60 Hz	4.81	4.13	3.50	3.03	2.56	2.16	1.83	1.57	1.33	1.06	0.894	0.770	0.684	0.595	0.499	0.401
Motor Power HP (kW)	1/8 (0.1)																	
	1/4 (0.2)																	
	1/3 (0.25)																	
	1/2 (0.4)																	
	3/4 (0.55)																	
	1 (0.75)																	
	1.5 (1.1)																	
	2 (1.5)																	
	3 (2.2)																	
	5 (3.7)																	
	7.5 (5.5)																	

- Standard efficiency motor
- Premium efficiency or IE3 motor

* Planetary Actual Ratio

Unit Size	Nominal Ratio	Actual Ratio	Actual RPM	
			50 Hz	60 Hz
A6100	11	10.50	138	167
A6105	18	16.80	86.3	104
B6120	11	10.50	138	167
B6125	18	17.13	84.6	102
C6140	11	10.89	133	161
C6145	18	17.50	82.9	100
D6160	11	10.85	134	161
D6165	18	17.77	81.6	98.5
E6170	11	10.86	133	161
E6175	18	17.68	82.0	99.0

How do I select a Cyclo® HBB reducer or gearmotor?

Selection is based on the actual horsepower and/or torque requirements at the output shaft. The Cyclo® HBB speed reducer has particularly high efficiencies over a wide range of reduction ratios, which frequently permits the use of reduced input power requirements (smaller HP motor) without sacrificing output shaft torque. The selection procedures in this catalog, will guide you in choosing the most efficient reducer for your application.

What information do I need to get started in the selection process?

To select the proper reducer for your application, you will need to know:

- Application: type of driven machine
- Hours of operation per day
- Motor horsepower (HP) and speed (RPM)
- Loading Conditions
- Mounting Position

If there are any special environmental factors or operation requirements, they must also be noted. This information will be important in determining the Service Factor of your application.

What are service factors and how are they used?

In general, reducers and gearmotors are rated for specific conditions and operating requirements of the application by the use of AGMA-defined Service Factors. There are three AGMA load classifications for gearmotors: I, II, and III (pages 3.6 - 3.7). The Service Factors are used in the product selection process to adjust for the specific conditions and operating requirements of your application.

What do I do if my application has particularly severe operating conditions?

The standard ratings for Cyclo® HBB are based on 10-hour daily service under conditions of uniform loads (equivalent to AGMA service factor 1.0). By following the product selection process, you will determine and apply the Service Factors to compensate for severe operating conditions.

How can I be sure that the reducer can withstand periodic excessive overloads?

Cyclo® HBB speed reducers provide 300% momentary intermittent shock loads capacity. For applications with shock loads greater than 300%, consult an SMA Application Engineer.

What are the standard input speeds?

In general terms, the speeds are 1750 and 1165 RPM at 60Hz, and 1450 and 980 RPM at 50Hz. The selection tables in this catalog are based on 1750 RPM. When other input speeds are used, the horsepower and torque ratings will vary.

What are the thermal limitations of the Cyclo® HBB?

The Cyclo® speed reducer, by virtue of its smooth, almost frictionless operation (unlike traditional helical gears), has a thermal rating that far exceeds its mechanical capacity and all but eliminates the conventional limitations due to heat.

Why is a Taper-Grip® bushing used? What is its material?

The Taper-Grip® bushing is integral to the Cyclo® HBB and provides for easy mounting and removal to and from the shaft of the driven machine. Because it requires no keyway, the shaft isn't weakened and maximum torque is transmitted. With the added strength of steel, the Taper-Grip® bushing can be used in reversing and/or high start-up applications. The steel Taper-Grip® bushing can be used on all Taper-Grip® products.

What kind of torque arm is supplied as standard? At what position should it be mounted?

The standard torque arm assembly is shown in the dimension pages. The torque arm should be mounted at 90 degrees to a line from the point of attachment to the reducer and the center of the output bore with plus or minus 15 degrees variance. It should always be mounted in tension, not compression. T-type and flange-mount (banjo) torque arms are also offered as options.

Common Configurations

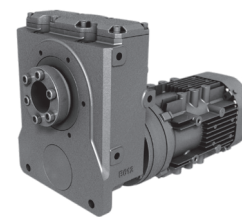

Single Reduction Gearmotor

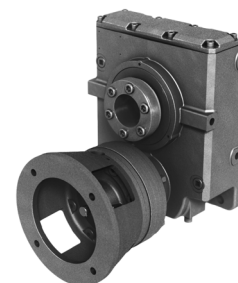

Single Reduction Reducer with C-Face Adapter

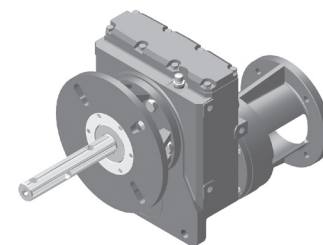

C-Face Reducer with Screw Conveyor Adapter

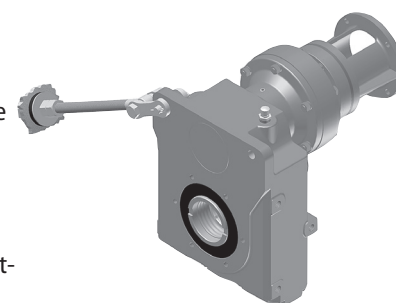

Double Reduction, C-Face Reducer with Torque Arm

Enhanced Performance (EP) Motors FAQs

What efficiency level are these Enhanced Performance (EP) motors?

The EP motor (applies to 1HP and above) is a Premium efficiency class, or International Efficiency 3 (IE3) design. Our integral fractional (less than 1HP) motors are not EP and are classified as standard efficiency IE1 motors.

What standards do these motors meet?

All Sumitomo motors are compliant with the Energy Policy and Conservation Act (EPAAct), as recently amended by the Department of Energy with a new ruling.

EP Sumitomo motors meet the efficiency levels promoted by the Consortium for Energy Efficiency (CEE) and meet the Canadian efficiency levels specified by NRCan.

The IE3 efficiency ratings conform to both the IEC Standard 60034-30:2009 and eco-design directive 2005/32/EC.

Will Sumitomo motors work with VFDs?

All current EP motors feature corona resistant magnet wire that extends the life of the insulation and enables the motors to resist the voltage spikes common with IGBT variable frequency drives.

What agency listings apply?

All EP motors in this product line are UL recognized, CSA certified and CE marked.

Can the motor be nameplated to operate at 50 hertz?

The motor can be nameplated and will operate at 50 hertz, but depending on the export destination, it may not meet that country's energy efficiency requirements. For areas requiring IE3 performance at 50 hertz, like Asia and Europe, other 50 hertz specific versions can be provided. Conformance with energy efficiency requirements in destination country is the responsibility of the customer.

Is the selection procedure the same as previous gearmotors?

Similar, the difference is restricted to applications with a large number of across the line starts and stops. Because the EP motors have more inertia and higher inrush current than previous integral motors, a supplemental service factor is applied to these applications using EP motors. The selection procedure for fractional HP units is unchanged.

Are the brakes the same?

The brakes are the same direct acting, fast response types used previously. For motors 1 HP and above they are a new larger model that has been redesigned to match the new motor profiles. Because the EP motor inertia is significantly higher, it may be necessary to adjust external trigger points or limit switches. Since the brake assembly shapes are different, old and new kits are not interchangeable.

What is the standard insulation system?

The motors continue with the Class F system, which limits the temperature rise to a Class B rise, where it bounds the allowable temperature rise to 80°C. It utilizes an insulation system capable of handling a 105°C rise to significantly extend insulation life.

Are EP motors interchangeable with old AF-motors?

The new EP motors without brake have the same 10:1 constant torque speed range as the AF-motor. Motors are dimensionally and performance-wise different so VFD re-programming may be required. For EP brakemotor with use on VFDs, the applicable speed range may be limited. Please consult the factory for options for EP brakemotors.

Will old motors continue to be available?

For motor powers 1 HP and above, EP motors have replaced the standard efficiency motors. (does not apply to fractional HP). 1HP+ Older motors do not meet the federally mandated efficiency requirements that went into effect on June 1, 2016. Non-compliant motors cannot be manufactured or imported into the United States.

Should I be concerned if I am replacing an older motor with the new EP motor?

For most applications, the use of the new EP motor will result in a more efficient, cooler-running and energy-saving motor. However, for applications with certain performance constraints, you may need to review the impact of the following:

- larger dimension and weight
- larger moment of inertia
- higher starting current and torque.

If taking an old standard efficiency motor off a gearmotor and replacing it with the same HP new EP motor, the EP motor will bolt to the old gearmotor. The motor flange diameters, pilot diameters, bolt patterns and shaft diameters all match. Motor body dimensions and weight will change.

Standard Specifications

	Standard Specifications	Standard Specifications with Built-In Brake	
3 Phase Integral Motor Fractional HP Motor	Capacity Range	1/8 through 3/4 HP (4 pole)	1/8 through 3/4 HP (4 pole)
	Power Supply	Motor Power: 230 / 460V, 60 Hz, 3 Phase 575V, 60 Hz, 3 Phase	Motor Power: 230 / 460V, 60 Hz, 3 Phase 575V, 60 Hz, 3 Phase Brake Power: 230 / 460V, 60 Hz, 1 Phase 575V, 60 Hz, 1 Phase
	Motor Standard	NEMA	NEMA
	Efficiency	Standard Efficiency (IE1)	Standard Efficiency (IE1)
	Protection	IP55	IP55
	Certification	CE Mark, UL Recognition, CSA Approval	CE Mark, UL Recognition, CSA Approval
	Conduit Box	Diecast Aluminum, NPT Conduit Thread	Diecast Aluminum, NPT Conduit Thread
	Inverter Operation	2:1 Constant Torque Speed Range 10:1 Optional (Select AF Motor) Insulation Meets NEMA MG1, Part 31	2:1 Constant Torque Speed Range 10:1 Optional (Select AF Motor) Insulation Meets NEMA MG1, Part 31
3 Phase Integral EP.NA Motor	Capacity Range	1 through 40 HP (4 pole)	1 through 40 HP (4 pole)
	Power Supply	Motor Power: 230 / 460V, 60 Hz, 3 Phase 575V, 60 Hz, 3 Phase	Motor Power: 230 / 460V, 60 Hz, 3 Phase 575V, 60 Hz, 3 Phase Brake Power: 230 / 460V, 60 Hz, 1 Phase 575V, 60 Hz, 1 Phase
	Motor Standard	NEMA	NEMA
	Efficiency	Premium Efficiency (IE3)	Premium Efficiency (IE3)
	Protection	IP55	IP55
	Certification	CE Mark, UL Recognition, CSA Approval	CE Mark, UL Recognition, CSA Approval
	Conduit Box	Diecast Aluminum, NPT Conduit Thread	Diecast Aluminum, NPT Conduit Thread
	Inverter Operation	10:1 Constant Torque Speed Range Insulation Meets NEMA MG1, Part 31	Constant Torque Speed Range: (4:1 or better) 10:1 Optional (Select SSC YA01 Motor - UL and CE Only) Insulation Meets NEMA MG1, Part 31
3 Phase Integral IE3 CE Motor	Capacity Range	0.75 through 30 kW (4 pole)	0.75 through 30 kW (4 pole)
	Power Supply	Motor Power (0.75 through 4.0 kW) 230 / 400V, 50 Hz, 3 Phase (5.5 through 30 kW) 400V, 50 Hz, 3 Phase	Motor Power (0.75 through 4.0 kW) 230 / 400V, 50 Hz, 3 Phase (5.5 through 30 kW) 400V, 50 Hz, 3 Phase Brake Power (0.75 through 4.0 kW) 220 - 240V, 50 Hz, 1 Phase (5.5 through 30 kW) 380 - 415V, 50 Hz, 1 Phase
	Motor Standard	IEC	IEC
	Efficiency	IE3	IE3
	Protection	IP55	IP44
	Certification	CE Mark	CE Mark
	Conduit Box	Diecast Aluminum, Metric Conduit Thread	Diecast Aluminum, Metric Conduit Thread
	Inverter Operation	5:1 Constant Torque Speed Range Spike Resistant Inverter Grade Wire Insulation	3:1 Constant Torque Speed Range Spike Resistant Inverter Grade Wire Insulation
3 Phase Integral Motor - Common	Enclosure	Totally Enclosed Fan Cooled (TEFC) 1/8 HP - Totally Enclosed Non-Ventilated (TENV)	Totally Enclosed Fan Cooled (TEFC) 1/8 HP - Totally Enclosed Non-Ventilated (TENV)
	Motor Type	Asynchronous Induction Motor, Squirrel Cage Rotor	Asynchronous Induction Motor, Squirrel Cage Rotor
	Frame Material	Diecast Aluminum	Diecast Aluminum
	Bearings	Double Shielded, Deep Groove, Ball Bearing, CM Clearance	Double Shielded, Deep Groove, Ball Bearing, CM Clearance
	Insulation	Class F	Class F - Motor and Brake
	Time Rating	Continuous	Continuous
HBB® Reducer	Reduction	Combination of Cyclo or Planetary input and helical gear output.	
	Lubrication	Cyclo portion is grease or oil, planetary and helical portions are oil lubricated.	
	Seals	Nitrile material, dual lipped, tandem output seals.	
	Material	Rugged cast iron housings in all sizes.	
	Paint Color	Blue, Munsell color number 6.5PB 3.6/8.2	
	Bearings	Output tapered roller bearings optional.	
Ambient Conditions	Installation Location	Indoor or outdoor with open cover.	
	Ambient Temperature	14° ~ 104° F (-10° ~ 40° C)	
	Ambient Humidity	Under 85%	
	Elevation	Under 3300 feet (1000 meters)	
	Atmosphere	Well ventilated location, free of corrosive gases, explosive gases, vapors, and dust	

Mounting Positions

Please see the Appendix (Section 5) for additional mounting configurations.

1. Mounting positions are shown with standard (Taper Grip Bushing) output option.
2. The plane of reference represents the location of customer's equipment.

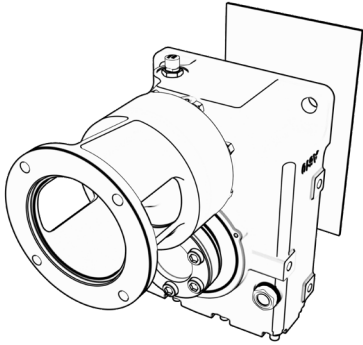

Y1

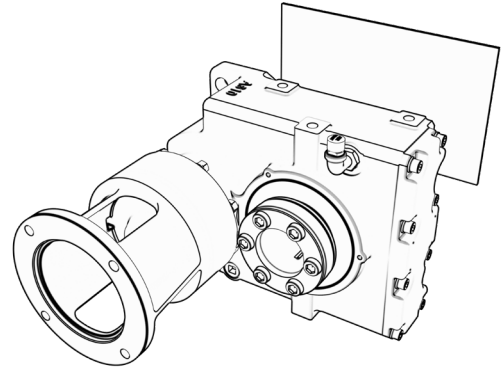

Y2

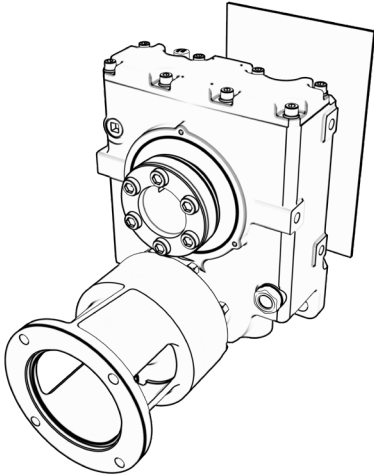

Y3

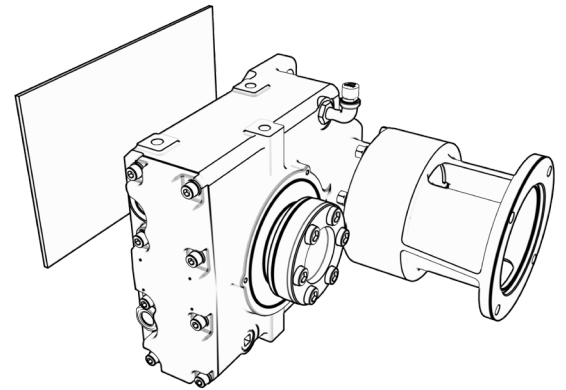

Y4

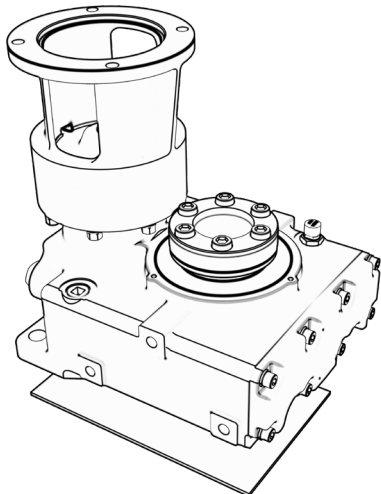

Y5

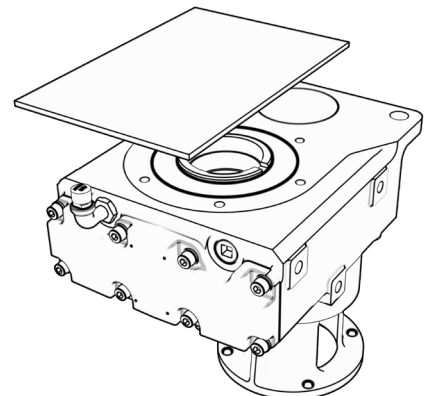

Y6

Additional Mounting Configurations

Flange Mounting Positions

Fig. 5.18 Hollow Shaft, Flange Mount

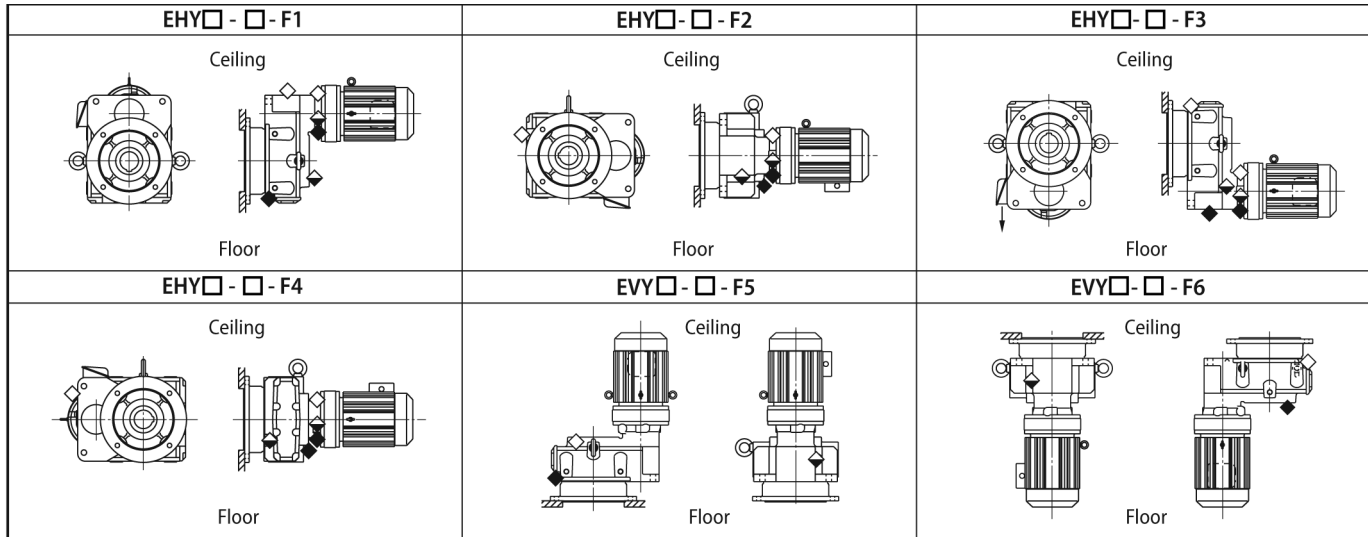

Notes: [1] □ indicates various nomenclature designations for input connection, frame size, ratio, etc. Please see pages 2.4 and 3.4 for complete reducer and gearmotor nomenclature.

[2] ◇ = Oil Fill Location; ◊ = Oil Level Location; ◆ = Oil Drain Location.

[3] For positions F5 and F6, the Cyclo® portion is grease-lubricated; oil fill and drain ports are unnecessary.

[4] For Cyclo® HBB sizes Z6090 - C6145 position F5 has two drain ports.

Page intentionally left blank.

2

Speed Reducers

Hollow Shaft Type

Cyclo® HBB

How to
Select

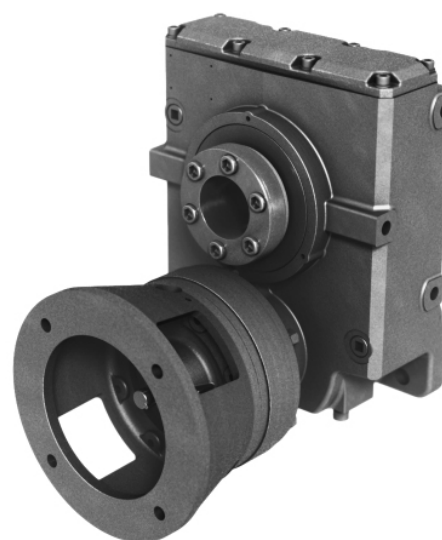

How to select a Speed Reducer

Cyclo® HBB

How to Select

Step 1: Collect data about your application

Before starting you need to know the:

- **Application (e.g. Conveyor, Mixer, etc.)**
- **Hours of Operation per day**
- **Motor Power (HP or kW) and Speed (RPM)**
- **Desired Output Speed**
- **Mounting Position and Style**
- **Overhung or Thrust Loads**
- **Bore Dimensions (inch or metric)**
- **Ambient Conditions**

Step 2: Choose a Mounting Position

Find the correct Mounting Position from the *Mounting Positions Table* on the right.

Step 3: Select a Frame Size

3A: Find the **Load Classification** of your application in the *AGMA Load Classification Table* on page 2.6.

3B: Find the recommended Service Factor using the *Recommended Reducer Service Factor Table* on the right.

3C: Determine the **Selection Horsepower** (HP or kW) by multiplying the Motor Power (HP or kW) by the Service Factor.

3D: Select a **Frame size** from the Reducer Selection Tables on pages 2.8–2.13 by matching both the Selection Horsepower and Desired Output Speed (RPMs) to a frame size model number. **Note:** For Mounting Positions Y1, Y2, Y3, Y4 see pages 2.8–2.9. For Mounting Positions Y5 and Y6 see pages 2.10–2.11). For all Double Reduction Mounting Positions see pages 2.12–2.13.

Step 4: Verify Dimensions

Use the Dimensions information on pages 2.14–2.20 to verify that the selected Frame Size is appropriate.

Step 5: Choose an Output Connection Method

Select keyed hollow bore or Taper-Grip® Bushing, and the associated bore size. For Taper-Grip® Bushing select a Bore Size from the *Stock Bushing Bore Size Table*.

Step 6: Choose Options

Please refer to Options section 4.1. For additional available options refer to our online Product Configurator at www.sumitomodrive.com/configurator

Step 7: Configure a Model Number

Go to page 2.4 to configure a model number. **Note:** You will use the information you gather from the procedure on this page to Configure a Model Number.

STOCK TAPER GRIP® BUSHING BORES

Size	Inch Sizes	Metric Sizes	Min. Bore*
Z	1 ³ / ₁₆ , 1 ⁷ / ₁₆ ,	30, 40	1 ³ / ₁₆
A	1 ¹⁵ / ₁₆ , 2 ³ / ₁₆	50, 55	1 ¹¹ / ₁₆
B	2 ³ / ₁₆ , 2 ⁷ / ₁₆	60, 65	1 ¹⁵ / ₁₆
C	2 ⁷ / ₁₆ , 2 ¹⁵ / ₁₆	65, 75	2 ³ / ₁₆
D	2 ¹⁵ / ₁₆ , 3 ⁷ / ₁₆	75, 85	2 ⁷ / ₁₆
E	3 ⁷ / ₁₆ , 3 ¹⁵ / ₁₆	90, 100	2 ¹⁵ / ₁₆



Mounting Positions

Y1

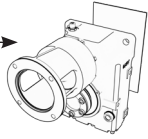

Y2

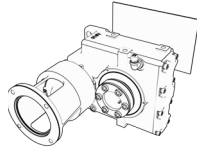

Y3

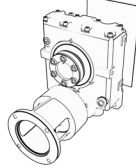

Y4

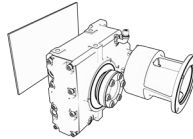

Y5

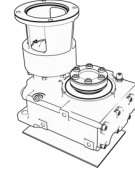

Y6

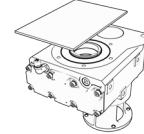

Recommended Reducer Service Factors

	AGMA Load Classifications		
	Uniform (U)	Moderate Shock (M)	Heavy Shock (H)
1/2 hr. per day (Occasional)	0.50 ⁽¹⁾	0.80 ⁽¹⁾	1.25
3 hrs. per day (Intermittent)	0.80	1.00	1.50
Up to 10 hrs. per day	1.00	1.25	1.75
24 hrs. per day	1.25	1.50	2.00

Note: (1) Maximum momentary or starting load must not exceed 300% of gear reducer rating (rating meaning service factor of 1.0). Time specified for occasional and intermittent service refers to total operating time per day.

Cyclo® HBB

How to Select

Determine Selection Horsepower (HP)

$$\text{Motor HP} \times \text{Service Factor} = \text{Selection HP}$$

Example: 10 Motor HP X 1.25 Service Factor = 12.5 Selection HP

Select a Frame Size

1 Match your OUTPUT RPM (or RATIO)...

Output RPM	20.0	17.2	14.3	11.6	9.80	8.47	7.04	5.75	4.20	Frame Size
Ratio	88	102	123	151	179	207	249	305	417	
Input Power HP (kW)	0.899 (0.671)	0.838 (0.625)	0.821 (0.612)	0.584 (0.435)	0.444 (0.332)	0.414 (0.309)	0.337 (0.252)	0.283 (0.211)	0.168 (0.125)	Z6090
Output Torque in-lbs (N-m)	2610 (295)	2830 (319)	3330 (377)	2920 (330)	2640 (298)	2840 (321)	2790 (315)	2870 (324)	2320 (262)	
Input Power HP (kW)	1.16 (0.866)	1.05 (0.784)	0.960 (0.716)	0.781 (0.583)	0.566 (0.422)	0.500 (0.373)	0.404 (0.301)	0.386 (0.288)	0.202 (0.151)	Z6095
Output Torque in-lbs (N-m)	3380 (381)	3540 (400)	3900 (441)	3900	3350	3430	3340 (377)	3900 (441)	2800 (316)	
Input Power HP (kW)	1.70 (1.27)	1.62 (1.21)	1.31 (0.975)				0.584 (0.436)	0.580 (0.433)	0.282 (0.210)	A6100
Output Torque in-lbs (N-m)	4950 (559)	5470 (618)	5330 (604)				4820 (545)	5870 (663)	3900 (440)	
Input Power HP (kW)	2.24 (1.67)	2.13 (1.59)	1.61 (1.20)				0.752 (0.561)	0.757 (0.565)	0.383 (0.286)	A6105
Output Torque in-lbs (N-m)	6510 (735)	7190 (812)	6540 (738)	(818)	(697)	(736)	6210 (701)	7660 (866)	5300 (599)	

2 ...to your SELECTION HP...

3 ...to find your FRAME SIZE

If Overhung Load is present, it must be checked against the capacity of the selection.



For special circumstances affecting Frame Size selection such as:

- Overhung Load
- Shock Loading

Consult Appendix, pages 5.7.

Configure a Model Number

Output Shaft Orientation

Type	Prefix
Horizontal	H
Vertical	V

Mounting Style

Type	Prefix
Flange (Keyed Hollow Bore) pg. 4.3	F
Shaft Mount (Hollow Shaft)	Y

Input Connection

Input Connection	Prefix
C-Face Adapter with jaw coupling	J
Quill Hollow Input	X
Free Input Shaft	

Modification

	Prefix
Special	S
Standard	

Required to be added at end of model number when ordering:

- Motor frame size for input adapter or Quill Hollow Input.
- Taper Grip Bushing or Keyed Hollow Bore diameter (refer to pages 4.2 to 4.3 for diameters)
- Optional conduit box positions must be specified, or standard is provided, refer to page 5.13
- Optional Industry Package, refer to page 4.6
- Specify type for nonstandard torque arm or no torque arm

Frame Size

Single Reduction		
Z6090	B6120	D6160
Z6095	B6125	D6165
A6100	C6140	E6170
A6105	C6145	E6175
Double Reduction		
Z609DA	C614DB	D616DC
A610DA	C614DC	E617DA
B612DA	D616DA	E617DB
B612DB	D616DB	E617DC
C614DA		

Shaft Specifications

Input Shaft	Hollow Output Shaft	Suffix
mm	Key (mm)	
Inch	Key (Inch)	K
mm	Taper-Grip®	M
Inch	Taper-Grip®	Y

Cyclo® HBB
Nomenclature

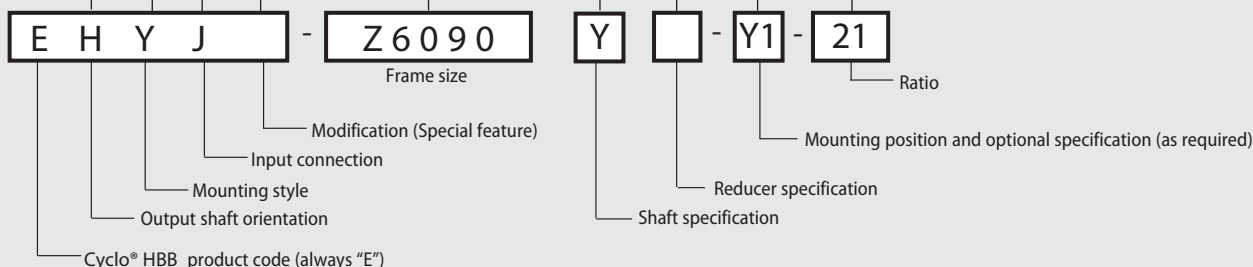

Nomenclature

Reducer Specification

Type	Suffix
Standard	
High Capacity Bearing (required for screw conveyor)	R1

Mounting Positions (Please see page 1.9 for additional mounting positions.)

Y1

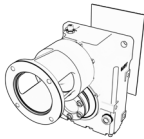

Y2

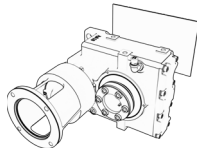

Y3

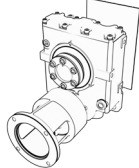

Y4

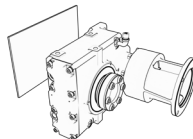

Y5

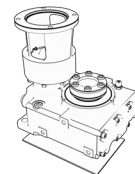

Y6

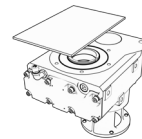

Cyclo® HBB

Nomenclature

Nominal Total Ratio

Single Reduction Input		Double Reduction Input	
Input Ratio	Total Ratio	Input Ratio	Total Ratio
3	11	104	364
5	18	121	424
6	21	143	501
8	28	165	578
11	39	195	683
13	46	231	809
15	53	273	956
17	60	319	1117
21	74	377	1320
25	88	473	1656
29	102	559	1957
35	123	649	2272
43	151	731	2559
51	179	841	2944
59	207	1003	3511
71	249	1247	4365
87	305	1479	5177
119	417	1849	6472
		2065	7228
		2537	8880
		3045	10568
		3481	12184
		4437	15530
		5133	17966
		6177	21620
		7569	26492

Nomenclature Example:

EHYJ – Z6090Y – Y1 – 21

- E** – Cyclo® Helical Buddybox **Z6090** – Frame Size
- H** – Horizontal Output **Y** – Inch Shaft Specification
- Y** – Shaft Mount (Hollow Shaft) **Y1** – Mounting Position
- J** – C-Face Input **21** – Ratio

AGMA Load Classifications

TYPE OF APPLICATION	TYPE OF LOAD
Agitators	
Pure liquids	U
Liquids and solids	M
Variable-density liquids	M
Blowers	
Centrifugal	U
Lobe	M
Vane	U
Brewing and Distilling	
Bottling machinery	U
Brew kettles, cont. duty	U
Cookers, cont. duty	U
Mash tubs, cont. duty	U
Scale hopper, frequent starts	M
Can Filling Machines	U
Cane Knives	M
Car Dumpers	H
Car Pullers	M
Clarifiers	U
Classifiers	M
Clay Working Machinery	
Brick press	H
Briquette machine	H
Clay working machinery	M
Pug mill	M
Compressors	
Centrifugal	U
Lobe	M
Reciprocating, multi-cylinder	M
Reciprocating, single-cylinder	H
Conveyors — Uniformly Loaded or Fed	
Apron	U
Assembly	U
Belt	U
Bucket	U
Chain	U
Flight	U
Oven	U
Screw	U
Conveyors — Heavy Duty, Not Uniformly Fed	
Apron	M
Assembly	M
Belt	M
Bucket	M
Chain	M
Flight	M
Live roll oven	M
Reciprocating	H
Screw	M
Shaker	H
Cranes (Except for Dry Dock Cranes)	
Main hoists	U
Bridge travel	S
Trolley travel	S
Crusher	
Ore H	H
Stone	H
Sugar	M
Dredges	
Cable reels	M
Conveyors	M
Cutter head drives	H
Jig drives	H
Maneuvering winches	M
Pumps	M
Screen drive	H
Stackers	M
Utility winches	M
Dry Dock Cranes	S
Elevators	
Bucket, uniform load	U
Bucket, heavy load	M
Bucket, cont.	U
Centrifugal discharge	U
Escalators	U
Freight	M
Gravity discharge	U
Man lifts	S
Passenger	S
Extruders (Plastics)	
Blow molders	M
Coating	U
Film	U
Pipe	U
Pre-plasticizers	M
Rods	U
Sheet	U
Tubing	U
Fans	
Centrifugal	U
Cooling towers	S
Forced draft	S
Induced draft	M
Large (mine, etc.)	M

TYPE OF APPLICATION	TYPE OF LOAD
Large (industrial)	M
Light (small diameter)	U
Feeders	
Apron	M
Belt	M
Disc	U
Reciprocating	H
Screw	M
Food Industry	
Beet slicer	M
Cereal cooker	U
Dough mixer	M
Meat grinders	M
Generators (Not Welding)	U
Hammer Mills	H
Hoists	
Heavy duty	H
Medium duty	M
Skip	M
Laundry Washers — Reversing	M
Laundry Tumblers	M
Line Shaft	
Drive processing equipment	M
Light	U
Other line shafts	U
Lumber Industry	
Barkers — hydraulic and mechanical	S
Burner conveyor	M
Chain Saw and Drag Saw	H
Chain transfer	H
Craneway transfer	H
De-barking drum	S
Edger feed	H
Gang feed	M
Geen chain	M
Live rolls	H
Log haul-lockline	H
Log turning device	H
Main log conveyor	H
Off bearing rolls	M
Planer feed chains	M
Planer floor chains	M
Planer tilting hoist	M
Re-saw merry-go-round conveyor	M
Roll cases	H
Slab conveyor	H
Small waste-conveyor-belt	U
Small waste-conveyor-chain	M
Sorting table	M
Tipple hoist conveyor	M
Tipple hoist drive	M
Transfer conveyors	M
Transfer rolls	M
Tray drive	M
Trimmer feed	M
Waste conveyor	M
Machine Tools	
Bending roll	M
Notching press, belt driven	S
Plate planer	H
Punch press, gear driven	H
Tapping machine	H
Other machine tools	
Main drives	M
Auxiliary drives	U
Metal Mills	
Draw bench carriage and main drive	M
Forming machines	H
Pinch, dryer and scrubber rolls, reversing	S
Slitters	M
Table conveyors, nonreversing	
Group drives	M
Individual drives	H
Table conveyors, reversing	S
Wire drawing and flattening machine	M
Wire winding machine	M
Mills, Rotary Type	
Ball M	
Cement kilns	M
Dryers and coolers	M
Kilns	M
Pebble	M
Rod, plain and wedge bar	M
Tumbling barrels	H
Mixers	
Concrete mixers, cont.	M
Concrete mixers, intermittent	M
Constant density	U
Variable density	M
Oil Industry	
Chillers	M
Oil well pumps	S
Paraffin filter press	M
Rotary kilns	M

TYPE OF APPLICATION	TYPE OF LOAD
Paper Mills	
Agitators (mixers)	M
Barker, hydraulic	S
Barker, mechanical	S
Barking drum	S
Beater and pulper	M
Bleacher	U
Calenders	M
Calenders, super	H
Converting machine (except cutters, platers)	M
Conveyors	U
Couch	M
Cutters, platers	H
Cylinders	M
Dryers	M
Felt stretcher	M
Felt whipper	H
Jordans	H
Log haul	H
Presses	U
Pulp machine reel	M
Stock chest	M
Suction roll	U
Washers and thickeners	M
Winders	U
Printing Presses	S
Pullers, Barge Haul	H
Pumps	
Centrifugal	U
Proportioning	M
Reciprocating	U
Single acting, 3 or more cylinders	M
Double acting, 2 or more cylinders	M
Rotary-gear type	U
Rubber and Plastics Industries	
Crackers	H
Laboratory equipment	M
Mixing mills	H
Refiners	M
Rubber calenders	M
Rubber mill (2 on line)	M
Rubber mill (3 on line)	U
Sheeter	M
Tire building machines	S
Tire and tube press openers	S
Tubers and strainers	M
Warming mills	M
Sand Muller	M
Screens	
Air washing	U
Rotary, stone or gravel	M
Traveling water intake	U
Sewage Disposal Equipment	
Bar screens	U
Chemical fenders	U
Collectors, circuline or straightline	U
Dewatering screens	M
Grit collectors	U
Scum breakers	M
Slow or rapid mixers	M
Sludge collectors	U
Thickeners	M
Vacuum filters	M
Slab Pushers	M
Steering Gear	S
Stokers	U
Sugar Industry	
Cane knives	M
Crushers	M
Mills	H
Textile Industry	
Batchers	M
Calenders	M
Cards	M
Dry cans	M
Dryers	M
Dyeing machinery	M
Knitting machines	S
Looms	M
Mangles	M
Nappers	M
Pads	M
Range drives	S
Slashers	M
Soapers	M
Spinners	M
Tenter frames	M
Washers	M
Winders	M
Windlass	S

U = Uniform Load H = Heavy Shock
M = Moderate Shock S = Contact Sumitomo

Cyclo® HBB
AGMA
Tables

This page intentionally left blank.

Cyclo® HBB



Single Reduction Selection Tables

1750 RPM - Quill, C-Face, and Free Input

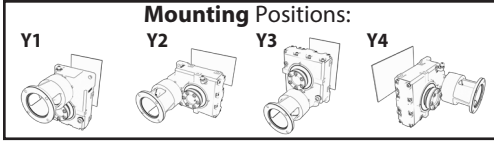

Single Reduction Selection Tables
 Y1, Y2, Y3, Y4: Pages 2.8 - 2.9
 Y5, Y6: Pages 2.10 - 2.11
 Double Reduction Selection Tables
 Y1, Y2, Y3, Y4, Y5, Y6: Pages 2.12 - 2.13

C-Face Dimensions Pages:
 Single Reduction 2.14-2.15
 Double Reduction 2.16-2.218
 Quill Dimensions Pages:
 Single Reduction 2.19
 Double Reduction 2.20

Cyclo® HBB

Selection
Tables

Output RPM	167	100	83.3	62.5	45.5	38.5	33.3	29.4	23.8	Frame Size
Ratio	11	18	21	28	39	46	53	60	74	
Input Power HP (kW)			1.54 (1.15)	1.54 (1.15)	1.54 (1.15)	1.54 (1.15)	1.54 (1.15)	1.54 (1.15)	1.02 (0.758)	Z6090
Output Torque in-lbs (N-m)			1070 (121)	1430 (162)	1970 (222)	2320 (262)	2680 (303)	3040 (343)	2480 (280)	
Input Power HP (kW)			2.03 (1.52)	2.03 (1.52)	2.03 (1.52)	2.03 (1.52)	2.03 (1.52)	1.98 (1.47)	1.60 (1.19)	Z6095
Output Torque in-lbs (N-m)			1420 (160)	1890 (213)	2600 (293)	3070 (347)	3540 (400)	3900 (441)	3900 (441)	
Input Power HP (kW)	3.15 (2.35)	3.28 (2.45)	3.15 (2.35)	3.15 (2.35)	3.15 (2.35)	3.15 (2.35)	3.15 (2.35)	2.66 (1.99)	2.58 (1.93)	A6100
Output Torque in-lbs (N-m)	1100 (124)	1910 (216)	2200 (248)	2930 (331)	4020 (455)	4760 (537)	5490 (620)	5260 (594)	6300 (712)	
Input Power HP (kW)	4.26 (3.18)	4.44 (3.31)	4.26 (3.18)	4.26 (3.18)	4.26 (3.18)	4.26 (3.18)	4.26 (3.18)	3.29 (2.46)	3.13 (2.34)	A6105
Output Torque in-lbs (N-m)	1490 (168)	2580 (292)	2970 (336)	3960 (448)	5450 (616)	6440 (728)	7430 (840)	6510 (735)	7650 (864)	
Input Power HP (kW)	6.80 (5.07)	6.94 (5.18)	6.80 (5.07)	6.80 (5.07)	6.80 (5.07)	6.80 (5.07)	6.80 (5.07)	6.80 (5.07)	5.31 (3.96)	B6120
Output Torque in-lbs (N-m)	2370 (268)	4040 (456)	4740 (536)	6320 (714)	8690 (982)	10300 (1160)	11900 (1340)	13400 (1520)	13000 (1460)	
Input Power HP (kW)	7.79 (5.81)	7.96 (5.93)	7.79 (5.81)	9.31 (6.95)	7.94 (5.92)	7.94 (5.92)	7.94 (5.92)	7.59 (5.66)	6.42 (4.79)	B6125
Output Torque in-lbs (N-m)	2720 (307)	4630 (523)	5430 (614)	8660 (979)	10100 (1150)	12000 (1360)	13800 (1560)	15000 (1690)	15700 (1770)	
Input Power HP (kW)	16.8 (12.5)	17.4 (13.0)	17.4 (13.0)	17.4 (13.0)	17.4 (13.0)	17.4 (13.0)	16.1 (12.0)	13.5 (10.1)	11.6 (8.66)	C6140
Output Torque in-lbs (N-m)	5860 (662)	10100 (1140)	12200 (1370)	16200 (1830)	22300 (2520)	26300 (2980)	28100 (3170)	26700 (3020)	28300 (3200)	
Input Power HP (kW)	19.5 (14.6)	20.2 (15.1)	20.2 (15.1)	20.2 (15.1)	20.2 (15.1)	20.2 (15.1)	18.0 (13.4)	15.9 (11.8)	12.8 (9.57)	C6145
Output Torque in-lbs (N-m)	6810 (769)	11800 (1330)	14100 (1600)	18800 (2130)	25900 (2930)	30500 (3450)	31300 (3540)	31300 (3540)	31300 (3540)	
Input Power HP (kW)	26.6 (19.8)	27.1 (20.2)	27.2 (20.3)	26.4 (19.7)	26.4 (19.7)	26.4 (19.7)	25.1 (18.7)	17.5 (13.1)	17.3 (12.9)	D6160
Output Torque in-lbs (N-m)	9270 (1050)	15700 (1780)	19000 (2140)	24600 (2770)	33800 (3820)	39900 (4510)	43800 (4950)	34600 (3910)	42200 (4770)	
Input Power HP (kW)	31.6 (23.5)	32.1 (24.0)	32.2 (24.1)	32.2 (24.1)	32.2 (24.1)	30.3 (22.6)	30.3 (22.6)	25.3 (18.8)	21.5 (16.1)	D6165
Output Torque in-lbs (N-m)	11000 (1240)	18700 (2110)	22500 (2540)	30000 (3390)	41200 (4660)	45800 (5170)	52800 (5970)	49900 (5640)	52600 (5940)	
Input Power HP (kW)	36.1 (26.9)	37.0 (27.6)	37.0 (27.6)	37.0 (27.6)	37.0 (27.6)	36.6 (27.3)	34.2 (25.5)	26.4 (19.7)	26.1 (19.5)	E6170
Output Torque in-lbs (N-m)	12600 (1420)	21500 (2430)	25800 (2920)	34400 (3890)	47300 (5350)	55300 (6240)	59600 (6740)	52100 (5880)	63800 (7210)	
Input Power HP (kW)	39.4 (29.4)	40.3 (30.1)	40.4 (30.1)	40.4 (30.1)	40.4 (30.1)	40.4 (30.1)	40.4 (30.1)	32.2 (24.1)	31.4 (23.4)	E6175
Output Torque in-lbs (N-m)	13700 (1550)	23400 (2650)	28200 (3180)	37600 (4250)	51700 (5840)	61100 (6900)	70500 (7960)	63700 (7200)	76600 (8650)	

Single Reduction Selection Tables

1750 RPM - Quill, C-Face, and Free Input

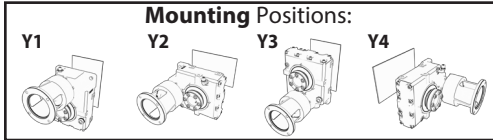

Single Reduction Selection Tables

Y1, Y2, Y3, Y4: Pages 2.8 - 2.9

Y5, Y6: Pages 2.10 - 2.11

Double Reduction Selection Tables

Y1, Y2, Y3, Y4, Y5, Y6: Pages 2.12 - 2.13

C-Face Dimensions Pages:

Single Reduction 2.14-2.15

Double Reduction 2.16-2.218

Quill Dimensions Pages:

Single Reduction 2.19

Double Reduction 2.20

Output RPM	20.0	17.2	14.3	11.6	9.80	8.47	7.04	5.75	4.20	Frame Size
Ratio	88	102	123	151	179	207	249	305	417	
Input Power HP <i>(kW)</i>	0.899 <i>(0.671)</i>	0.838 <i>(0.625)</i>	0.821 <i>(0.612)</i>	0.584 <i>(0.435)</i>	0.444 <i>(0.332)</i>	0.414 <i>(0.309)</i>	0.337 <i>(0.252)</i>	0.283 <i>(0.211)</i>	0.168 <i>(0.125)</i>	Z6090
Output Torque in-lbs <i>(N-m)</i>	2610 <i>(295)</i>	2830 <i>(319)</i>	3340 <i>(377)</i>	2920 <i>(330)</i>	2640 <i>(298)</i>	2840 <i>(321)</i>	2790 <i>(315)</i>	2870 <i>(324)</i>	2320 <i>(262)</i>	
Input Power HP <i>(kW)</i>	1.16 <i>(0.866)</i>	1.05 <i>(0.784)</i>	0.960 <i>(0.716)</i>	0.781 <i>(0.583)</i>	0.566 <i>(0.422)</i>	0.500 <i>(0.373)</i>	0.404 <i>(0.301)</i>	0.386 <i>(0.288)</i>	0.202 <i>(0.151)</i>	Z6095
Output Torque in-lbs <i>(N-m)</i>	3380 <i>(381)</i>	3540 <i>(400)</i>	3900 <i>(441)</i>	3900 <i>(441)</i>	3350 <i>(379)</i>	3430 <i>(388)</i>	3340 <i>(377)</i>	3900 <i>(441)</i>	2800 <i>(316)</i>	
Input Power HP <i>(kW)</i>	1.70 <i>(1.27)</i>	1.62 <i>(1.21)</i>	1.31 <i>(0.975)</i>	1.05 <i>(0.780)</i>	0.751 <i>(0.560)</i>	0.692 <i>(0.516)</i>	0.584 <i>(0.436)</i>	0.580 <i>(0.433)</i>	0.282 <i>(0.210)</i>	A6100
Output Torque in-lbs <i>(N-m)</i>	4950 <i>(559)</i>	5470 <i>(618)</i>	5320 <i>(601)</i>	5230 <i>(591)</i>	4450 <i>(503)</i>	4750 <i>(536)</i>	4820 <i>(545)</i>	5870 <i>(663)</i>	3900 <i>(440)</i>	
Input Power HP <i>(kW)</i>	2.24 <i>(1.67)</i>	2.13 <i>(1.59)</i>	1.61 <i>(1.20)</i>	1.45 <i>(1.08)</i>	1.04 <i>(0.776)</i>	0.949 <i>(0.708)</i>	0.752 <i>(0.561)</i>	0.757 <i>(0.565)</i>	0.383 <i>(0.286)</i>	A6105
Output Torque in-lbs <i>(N-m)</i>	6510 <i>(735)</i>	7190 <i>(812)</i>	6540 <i>(738)</i>	7240 <i>(818)</i>	6170 <i>(697)</i>	6510 <i>(736)</i>	6210 <i>(701)</i>	7660 <i>(866)</i>	5300 <i>(599)</i>	
Input Power HP <i>(kW)</i>	4.14 <i>(3.09)</i>	4.01 <i>(2.99)</i>	3.34 <i>(2.49)</i>	2.56 <i>(1.91)</i>	2.30 <i>(1.72)</i>	1.74 <i>(1.30)</i>	1.28 <i>(0.957)</i>	1.27 <i>(0.944)</i>		B6120
Output Torque in-lbs <i>(N-m)</i>	12000 <i>(1360)</i>	13500 <i>(1530)</i>	13600 <i>(1530)</i>	12800 <i>(1450)</i>	13600 <i>(1540)</i>	12000 <i>(1350)</i>	10600 <i>(1200)</i>	12800 <i>(1450)</i>		
Input Power HP <i>(kW)</i>	5.30 <i>(3.96)</i>	4.65 <i>(3.47)</i>	3.85 <i>(2.87)</i>	3.13 <i>(2.34)</i>	2.64 <i>(1.97)</i>	2.17 <i>(1.62)</i>	1.61 <i>(1.20)</i>	1.51 <i>(1.13)</i>		B6125
Output Torque in-lbs <i>(N-m)</i>	15400 <i>(1740)</i>	15700 <i>(1770)</i>	15700 <i>(1770)</i>	15700 <i>(1770)</i>	15700 <i>(1770)</i>	14900 <i>(1680)</i>	13300 <i>(1500)</i>	15300 <i>(1730)</i>		
Input Power HP <i>(kW)</i>	9.23 <i>(6.89)</i>	7.98 <i>(5.95)</i>	6.98 <i>(5.21)</i>	5.28 <i>(3.94)</i>	4.60 <i>(3.43)</i>	3.97 <i>(2.96)</i>	3.26 <i>(2.43)</i>	2.65 <i>(1.98)</i>		C6140
Output Torque in-lbs <i>(N-m)</i>	26800 <i>(3030)</i>	26900 <i>(3040)</i>	28400 <i>(3210)</i>	26400 <i>(2980)</i>	27200 <i>(3080)</i>	27200 <i>(3080)</i>	26900 <i>(3040)</i>	26800 <i>(3030)</i>		
Input Power HP <i>(kW)</i>	10.6 <i>(7.91)</i>	9.29 <i>(6.93)</i>	7.70 <i>(5.74)</i>	6.27 <i>(4.67)</i>	5.28 <i>(3.94)</i>	4.57 <i>(3.41)</i>	3.80 <i>(2.83)</i>	3.10 <i>(2.31)</i>		C6145
Output Torque in-lbs <i>(N-m)</i>	30800 <i>(3480)</i>	31300 <i>(3540)</i>	31300 <i>(3540)</i>	31300 <i>(3540)</i>	31300 <i>(3540)</i>	31300 <i>(3540)</i>	31300 <i>(3540)</i>	31300 <i>(3540)</i>		
Input Power HP <i>(kW)</i>	13.2 <i>(9.86)</i>	14.1 <i>(10.5)</i>	13.0 <i>(9.67)</i>	9.99 <i>(7.45)</i>	7.71 <i>(5.75)</i>	5.92 <i>(4.42)</i>	4.65 <i>(3.47)</i>	4.65 <i>(3.47)</i>		D6160
Output Torque in-lbs <i>(N-m)</i>	38400 <i>(4340)</i>	47500 <i>(5360)</i>	52800 <i>(5960)</i>	49900 <i>(5640)</i>	45700 <i>(5170)</i>	40600 <i>(4590)</i>	38400 <i>(4340)</i>	47100 <i>(5320)</i>		
Input Power HP <i>(kW)</i>	18.9 <i>(14.1)</i>	15.3 <i>(11.4)</i>	13.5 <i>(10.1)</i>	10.6 <i>(7.91)</i>	9.25 <i>(6.90)</i>	7.71 <i>(5.75)</i>	6.65 <i>(4.96)</i>	5.22 <i>(3.90)</i>		D6165
Output Torque in-lbs <i>(N-m)</i>	54900 <i>(6200)</i>	51600 <i>(5830)</i>	54900 <i>(6200)</i>	53000 <i>(5990)</i>	54900 <i>(6200)</i>	52900 <i>(5970)</i>	54900 <i>(6200)</i>	52800 <i>(5970)</i>		
Input Power HP <i>(kW)</i>	21.2 <i>(15.8)</i>	19.2 <i>(14.3)</i>	16.1 <i>(12.0)</i>	13.1 <i>(9.75)</i>	11.2 <i>(8.39)</i>	9.58 <i>(7.15)</i>	7.94 <i>(5.92)</i>	6.45 <i>(4.81)</i>		E6170
Output Torque in-lbs <i>(N-m)</i>	61600 <i>(6960)</i>	64600 <i>(7300)</i>	65500 <i>(7400)</i>	65300 <i>(7380)</i>	66700 <i>(7540)</i>	65800 <i>(7430)</i>	65500 <i>(7400)</i>	65200 <i>(7370)</i>		
Input Power HP <i>(kW)</i>	26.3 <i>(19.7)</i>	22.7 <i>(16.9)</i>	18.8 <i>(14.0)</i>	15.2 <i>(11.3)</i>	12.9 <i>(9.63)</i>	11.2 <i>(8.33)</i>	9.28 <i>(6.92)</i>	7.57 <i>(5.65)</i>		E6175
Output Torque in-lbs <i>(N-m)</i>	76600 <i>(8650)</i>	76600 <i>(8650)</i>	76600 <i>(8650)</i>	75700 <i>(8560)</i>	76600 <i>(8650)</i>	76600 <i>(8650)</i>	76600 <i>(8650)</i>	76600 <i>(8650)</i>		

Cyclo® HBB

Selection Tables

Single Reduction Selection Tables

1750 RPM - Quill, C-Face, and Free Input

Mounting Positions:

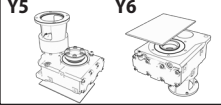

Single Reduction Selection Tables

Y1, Y2, Y3, Y4: Pages 2.8 - 2.9

Y5, Y6: Pages 2.10 - 2.11

Double Reduction Selection Tables

Y1, Y2, Y3, Y4, Y5, Y6: Pages 2.12 - 2.13

C-Face Dimensions Pages:

Single Reduction 2.14-2.15

Double Reduction 2.16-2.218

Quill Dimensions Pages:

Single Reduction 2.19

Double Reduction 2.20

Output RPM	167	100	83.3	62.5	45.5	38.5	33.3	29.4	23.8	Frame Size
Ratio	11	18	21	28	39	46	53	60	74	
Input Power HP (kW)			1.54 (1.15)	1.54 (1.15)	1.54 (1.15)	1.54 (1.15)	1.54 (1.15)	1.54 (1.15)	1.02 (0.758)	Z6090
Output Torque in-lbs (N-m)			1070 (121)	1430 (162)	1970 (222)	2320 (262)	2680 (303)	3040 (343)	2480 (280)	
Input Power HP (kW)			2.03 (1.52)	2.03 (1.52)	2.03 (1.52)	2.03 (1.52)	2.03 (1.52)	1.98 (1.47)	1.60 (1.19)	Z6095
Output Torque in-lbs (N-m)			1420 (160)	1890 (213)	2600 (293)	3070 (347)	3540 (400)	3900 (441)	3900 (441)	
Input Power HP (kW)	3.15 (2.35)	3.28 (2.45)	3.15 (2.35)	3.15 (2.35)	3.15 (2.35)	3.15 (2.35)	3.15 (2.35)	2.66 (1.99)	2.58 (1.93)	A6100
Output Torque in-lbs (N-m)	1100 (124)	1910 (216)	2200 (248)	2930 (331)	4020 (455)	4760 (537)	5490 (620)	5260 (594)	6300 (712)	
Input Power HP (kW)	4.26 (3.18)	4.44 (3.31)	4.26 (3.18)	4.26 (3.18)	4.26 (3.18)	4.26 (3.18)	4.26 (3.18)	3.29 (2.46)	3.13 (2.34)	A6105
Output Torque in-lbs (N-m)	1490 (168)	2580 (292)	2970 (336)	3960 (448)	5450 (616)	6440 (728)	7430 (840)	6510 (735)	7650 (864)	
Input Power HP (kW)	6.80 (5.07)	6.94 (5.18)	6.80 (5.07)	6.80 (5.07)	6.80 (5.07)	6.80 (5.07)	6.80 (5.07)	6.80 (5.07)	5.31 (3.96)	B6120
Output Torque in-lbs (N-m)	2370 (268)	4040 (456)	4740 (536)	6320 (714)	8690 (982)	10300 (1160)	11900 (1340)	13400 (1520)	13000 (1460)	
Input Power HP (kW)	7.79 (5.81)	7.96 (5.93)	7.79 (5.81)	9.31 (6.95)	7.94 (5.92)	7.94 (5.92)	7.94 (5.92)	7.59 (5.66)	6.42 (4.79)	B6125
Output Torque in-lbs (N-m)	2720 (307)	4630 (523)	5430 (614)	8660 (979)	10100 (1150)	12000 (1360)	13800 (1560)	15000 (1690)	15700 (1770)	
Input Power HP (kW)	12.2 (9.13)	12.7 (9.47)	14.9 (11.1)	14.9 (11.1)	14.9 (11.1)	10.2 (7.58)	10.2 (7.58)	7.45 (5.56)	7.45 (5.56)	C6140
Output Torque in-lbs (N-m)	4270 (482)	7380 (834)	10400 (1170)	13800 (1560)	19000 (2150)	15300 (1730)	17700 (2000)	14700 (1660)	18200 (2050)	
Input Power HP (kW)	14.2 (10.6)	14.7 (11.0)	14.9 (11.1)	14.9 (11.1)	14.9 (11.1)	10.2 (7.58)	10.2 (7.58)	7.45 (5.56)	7.45 (5.56)	C6145
Output Torque in-lbs (N-m)	4960 (560)	8570 (969)	10400 (1170)	13800 (1560)	19000 (2150)	15300 (1730)	17700 (2000)	14700 (1660)	18200 (2050)	
Input Power HP (kW)	16.5 (12.3)	16.8 (12.5)		20.3 (15.2)	20.3 (15.2)	14.9 (11.1)	14.9 (11.1)	14.9 (11.1)	10.2 (7.58)	D6160
Output Torque in-lbs (N-m)	5760 (650)	9760 (1100)		18900 (2130)	26000 (2930)	22500 (2540)	26000 (2930)	29400 (3330)	24800 (2800)	
Input Power HP (kW)	19.6 (14.7)	20.0 (14.9)		20.3 (15.2)	20.3 (15.2)	14.9 (11.1)	14.9 (11.1)	14.9 (11.1)	10.2 (7.58)	D6165
Output Torque in-lbs (N-m)	6850 (774)	11600 (1310)		18900 (2130)	26000 (2930)	22500 (2540)	26000 (2930)	29400 (3330)	24800 (2800)	
Input Power HP (kW)	26.4 (19.7)	27.1 (20.2)			19.1 (14.2)	19.1 (14.2)	16.1 (12.0)	13.0 (9.71)	13.0 (9.71)	E6170
Output Torque in-lbs (N-m)	9220 (1040)	15700 (1780)			24400 (2760)	28900 (3260)	28000 (3160)	25700 (2910)	31800 (3590)	
Input Power HP (kW)	28.8 (21.5)	29.5 (22.0)			19.1 (14.2)	19.1 (14.2)	16.1 (12.0)	13.0 (9.71)	13.0 (9.71)	E6175
Output Torque in-lbs (N-m)	10000 (1130)	17100 (1940)			24400 (2760)	28900 (3260)	28000 (3160)	25700 (2910)	31800 (3590)	

Cyclo® HBB

Selection Tables

Single Reduction Selection Tables

1750 RPM - Quill, C-Face, and Free Input

Mounting Positions:

Y5

Y6

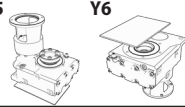

Single Reduction Selection Tables

Y1, Y2, Y3, Y4: Pages 2.8 - 2.9

Y5, Y6: Pages 2.10 - 2.11

Double Reduction Selection Tables

Y1, Y2, Y3, Y4, Y5, Y6: Pages 2.12 - 2.13

C-Face Dimensions Pages:

Single Reduction 2.14-2.15

Double Reduction 2.16-2.218

Quil Dimensions Pages:

Single Reduction 2.19

Double Reduction 2.20

Output RPM	20.0	17.2	14.3	11.6	9.80	8.47	7.04	5.75	4.20	Frame Size
Ratio	88	102	123	151	179	207	249	305	417	
Input Power HP <i>(kW)</i>	0.899 <i>(0.671)</i>	0.838 <i>(0.625)</i>	0.821 <i>(0.612)</i>	0.584 <i>(0.435)</i>	0.444 <i>(0.332)</i>	0.414 <i>(0.309)</i>	0.337 <i>(0.252)</i>	0.283 <i>(0.211)</i>	0.168 <i>(0.125)</i>	Z6090
Output Torque in-lbs <i>(N-m)</i>	2610 <i>(295)</i>	2830 <i>(319)</i>	3340 <i>(377)</i>	2920 <i>(330)</i>	2640 <i>(298)</i>	2840 <i>(321)</i>	2790 <i>(315)</i>	2870 <i>(324)</i>	2320 <i>(262)</i>	
Input Power HP <i>(kW)</i>	1.16 <i>(0.866)</i>	1.05 <i>(0.784)</i>	0.960 <i>(0.716)</i>	0.781 <i>(0.583)</i>	0.566 <i>(0.422)</i>	0.500 <i>(0.373)</i>	0.404 <i>(0.301)</i>	0.386 <i>(0.288)</i>	0.202 <i>(0.151)</i>	Z6095
Output Torque in-lbs <i>(N-m)</i>	3380 <i>(381)</i>	3540 <i>(400)</i>	3900 <i>(441)</i>	3900 <i>(441)</i>	3350 <i>(379)</i>	3430 <i>(388)</i>	3340 <i>(377)</i>	3900 <i>(441)</i>	2800 <i>(316)</i>	
Input Power HP <i>(kW)</i>	1.70 <i>(1.27)</i>	1.62 <i>(1.21)</i>	1.31 <i>(0.975)</i>	1.05 <i>(0.780)</i>	0.751 <i>(0.560)</i>	0.692 <i>(0.516)</i>	0.584 <i>(0.436)</i>	0.580 <i>(0.433)</i>	0.282 <i>(0.210)</i>	A6100
Output Torque in-lbs <i>(N-m)</i>	4950 <i>(559)</i>	5470 <i>(618)</i>	5320 <i>(601)</i>	5230 <i>(591)</i>	4450 <i>(503)</i>	4750 <i>(536)</i>	4820 <i>(545)</i>	5870 <i>(663)</i>	3900 <i>(440)</i>	
Input Power HP <i>(kW)</i>	2.24 <i>(1.67)</i>	2.13 <i>(1.59)</i>	1.61 <i>(1.20)</i>	1.45 <i>(1.08)</i>	1.04 <i>(0.776)</i>	0.949 <i>(0.708)</i>	0.752 <i>(0.561)</i>	0.757 <i>(0.565)</i>	0.383 <i>(0.286)</i>	A6105
Output Torque in-lbs <i>(N-m)</i>	6510 <i>(735)</i>	7190 <i>(812)</i>	6540 <i>(738)</i>	7240 <i>(818)</i>	6170 <i>(697)</i>	6510 <i>(736)</i>	6210 <i>(701)</i>	7660 <i>(866)</i>	5300 <i>(599)</i>	
Input Power HP <i>(kW)</i>	4.14 <i>(3.09)</i>	4.01 <i>(2.99)</i>	3.34 <i>(2.49)</i>	2.56 <i>(1.91)</i>	2.30 <i>(1.72)</i>	1.74 <i>(1.30)</i>	1.28 <i>(0.957)</i>	1.27 <i>(0.944)</i>		B6120
Output Torque in-lbs <i>(N-m)</i>	12000 <i>(1360)</i>	13500 <i>(1530)</i>	13600 <i>(1530)</i>	12800 <i>(1450)</i>	13600 <i>(1540)</i>	12000 <i>(1350)</i>	10600 <i>(1200)</i>	12800 <i>(1450)</i>		
Input Power HP <i>(kW)</i>	5.30 <i>(3.96)</i>	4.65 <i>(3.47)</i>	3.85 <i>(2.87)</i>	3.13 <i>(2.34)</i>	2.64 <i>(1.97)</i>	2.17 <i>(1.62)</i>	1.61 <i>(1.20)</i>	1.51 <i>(1.13)</i>		B6125
Output Torque in-lbs <i>(N-m)</i>	15400 <i>(1740)</i>	15700 <i>(1770)</i>	15700 <i>(1770)</i>	15700 <i>(1770)</i>	15700 <i>(1770)</i>	14900 <i>(1680)</i>	13300 <i>(1500)</i>	15300 <i>(1730)</i>		
Input Power HP <i>(kW)</i>	7.45 <i>(5.56)</i>	5.01 <i>(3.74)</i>	5.01 <i>(3.74)</i>	2.98 <i>(2.22)</i>	2.98 <i>(2.22)</i>	2.98 <i>(2.22)</i>	2.03 <i>(1.52)</i>	2.03 <i>(1.52)</i>		C6140
Output Torque in-lbs <i>(N-m)</i>	21600 <i>(2450)</i>	16900 <i>(1910)</i>	20400 <i>(2300)</i>	14900 <i>(1680)</i>	17600 <i>(1990)</i>	20400 <i>(2310)</i>	16800 <i>(1890)</i>	20500 <i>(2320)</i>		
Input Power HP <i>(kW)</i>	7.45 <i>(5.56)</i>	5.01 <i>(3.74)</i>	5.01 <i>(3.74)</i>	2.98 <i>(2.22)</i>	2.98 <i>(2.22)</i>	2.98 <i>(2.22)</i>	2.03 <i>(1.52)</i>	2.03 <i>(1.52)</i>		C6145
Output Torque in-lbs <i>(N-m)</i>	21600 <i>(2450)</i>	16900 <i>(1910)</i>	20400 <i>(2300)</i>	14900 <i>(1680)</i>	17600 <i>(1990)</i>	20400 <i>(2310)</i>	16800 <i>(1890)</i>	20500 <i>(2320)</i>		
Input Power HP <i>(kW)</i>	10.2 <i>(7.58)</i>	10.2 <i>(7.58)</i>	10.2 <i>(7.58)</i>	5.01 <i>(3.74)</i>	5.01 <i>(3.74)</i>	5.01 <i>(3.74)</i>	2.98 <i>(2.22)</i>	2.98 <i>(2.22)</i>		D6160
Output Torque in-lbs <i>(N-m)</i>	29500 <i>(3330)</i>	34200 <i>(3870)</i>	41300 <i>(4670)</i>	25000 <i>(2830)</i>	29700 <i>(3360)</i>	34400 <i>(3880)</i>	24600 <i>(2780)</i>	30100 <i>(3400)</i>		
Input Power HP <i>(kW)</i>	10.2 <i>(7.58)</i>	10.2 <i>(7.58)</i>	10.2 <i>(7.58)</i>	5.01 <i>(3.74)</i>	5.01 <i>(3.74)</i>	5.01 <i>(3.74)</i>	2.98 <i>(2.22)</i>	2.98 <i>(2.22)</i>		D6165
Output Torque in-lbs <i>(N-m)</i>	29500 <i>(3330)</i>	34200 <i>(3870)</i>	41300 <i>(4670)</i>	25000 <i>(2830)</i>	29700 <i>(3360)</i>	34400 <i>(3880)</i>	24600 <i>(2780)</i>	30100 <i>(3400)</i>		
Input Power HP <i>(kW)</i>	14.9 <i>(11.1)</i>	14.9 <i>(11.1)</i>	10.2 <i>(7.58)</i>	10.2 <i>(7.58)</i>	7.45 <i>(5.56)</i>	7.45 <i>(5.56)</i>	5.01 <i>(3.74)</i>	5.01 <i>(3.74)</i>		E6170
Output Torque in-lbs <i>(N-m)</i>	43300 <i>(4890)</i>	50200 <i>(5670)</i>	41300 <i>(4670)</i>	50800 <i>(5740)</i>	44200 <i>(4990)</i>	51100 <i>(5770)</i>	41400 <i>(4670)</i>	50700 <i>(5730)</i>		
Input Power HP <i>(kW)</i>	14.9 <i>(11.1)</i>	14.9 <i>(11.1)</i>	10.2 <i>(7.58)</i>	10.2 <i>(7.58)</i>	7.45 <i>(5.56)</i>	7.45 <i>(5.56)</i>	5.01 <i>(3.74)</i>	5.01 <i>(3.74)</i>		E6175
Output Torque in-lbs <i>(N-m)</i>	43300 <i>(4890)</i>	50200 <i>(5670)</i>	41300 <i>(4670)</i>	50800 <i>(5740)</i>	44200 <i>(4990)</i>	51100 <i>(5770)</i>	41400 <i>(4670)</i>	50700 <i>(5730)</i>		

Cyclo® HBB

Selection Tables

Double Reduction Selection Tables

1750 RPM - Quill, C-Face, and Free Input

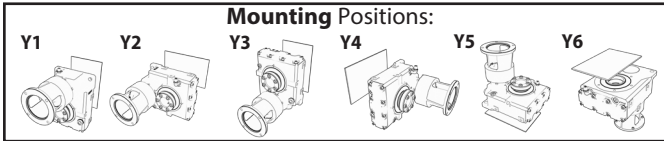

Single Reduction Selection Tables

Y1, Y2, Y3, Y4: Pages 2.8 - 2.9

Y5, Y6: Pages 2.10 - 2.11

Double Reduction Selection Tables

Y1, Y2, Y3, Y4, Y5, Y6: Pages 2.12 - 2.13

C-Face Dimensions Pages:

Single Reduction 2.14-2.15

Double Reduction 2.16-2.218

Quill Dimensions Pages:

Single Reduction 2.19

Double Reduction 2.20

Output RPM	4.81	4.13	3.50	3.03	2.56	2.16	1.83	1.57	1.33	1.06	0.894	0.770	0.684	Frame Size
Ratio	364	424	501	578	683	809	956	1117	1320	1656	1957	2272	2559	
Input Power HP (kW)	0.337 (0.251)	0.290 (0.216)	0.245 (0.183)	0.212 (0.158)	0.180 (0.134)	0.152 (0.113)	1/8* (0.1)*	1/8* (0.1)*	1/8* (0.1)*	1/8* (0.1)*	1/8* (0.1)*	1/8* (0.1)*	1/8* (0.1)*	Z609DA
Output Torque in-lbs (N-m)	3870 (437)	3870 (437)	3870 (437)	3870 (437)	3870 (437)	3870 (437)	3870 (437)	3870 (437)	3870 (437)	3870 (437)	3870 (437)	3870 (437)	3870 (437)	
Input Power HP (kW)	0.576 (0.429)	0.576 (0.429)	0.496 (0.370)	0.430 (0.321)	0.364 (0.271)	0.307 (0.229)	0.260 (0.194)	0.222 (0.166)	0.188 (0.140)	0.150 (0.112)	1/8* (0.1)*	1/8* (0.1)*	1/8* (0.1)*	A610DA
Output Torque in-lbs (N-m)	6610 (746)	7690 (868)	7820 (884)	7820 (884)	7820 (884)	7820 (884)	7820 (884)	7820 (884)	7820 (884)	7820 (884)	7820 (884)	7820 (884)	7820 (884)	
Input Power HP (kW)	0.576 (0.429)	0.576 (0.429)	0.576 (0.429)	0.576 (0.429)	0.576 (0.429)	0.576 (0.429)	0.520 (0.388)	0.445 (0.332)	0.377 (0.281)	0.300 (0.224)	0.254 (0.189)	0.219 (0.163)	0.194 (0.145)	B612DA
Output Torque in-lbs (N-m)	6610 (746)	7690 (868)	9080 (1030)	10500 (1180)	12400 (1400)	14700 (1660)	15700 (1770)	15700 (1770)	15700 (1770)	15700 (1770)	15700 (1770)	15700 (1770)	15700 (1770)	
Input Power HP (kW)	1.37 (1.02)	1.17 (0.875)	0.993 (0.741)	0.860 (0.642)	0.728 (0.543)	0.615 (0.458)	0.520 (0.388)	0.445 (0.332)	0.377 (0.281)	0.300 (0.224)	0.254 (0.189)	0.219 (0.163)	0.194 (0.145)	B612DB
Output Torque in-lbs (N-m)	15700 (1770)	15700 (1770)	15700 (1770)	15700 (1770)	15700 (1770)	15700 (1770)	15700 (1770)	15700 (1770)	15700 (1770)	15700 (1770)	15700 (1770)	15700 (1770)	15700 (1770)	
Input Power HP (kW)	0.576 (0.429)	0.576 (0.429)	0.576 (0.429)	0.576 (0.429)	0.576 (0.429)	0.576 (0.429)	0.576 (0.429)	0.576 (0.429)	0.576 (0.429)	0.576 (0.429)	0.508 (0.379)	0.438 (0.326)	0.388 (0.290)	C614DA
Output Torque in-lbs (N-m)	6610 (746)	7690 (868)	9080 (1030)	10500 (1180)	12400 (1400)	14700 (1660)	17300 (1960)	20300 (2290)	23900 (2710)	30000 (3390)	31300 (3540)	31300 (3540)	31300 (3540)	
Input Power HP (kW)	2.14 (1.60)	2.14 (1.60)	1.99 (1.48)	1.72 (1.28)	1.46 (1.09)	1.23 (0.917)	1.04 (0.776)	0.890 (0.664)	0.753 (0.562)	0.600 (0.448)	0.508 (0.379)	0.438 (0.326)	0.388 (0.290)	C614DB
Output Torque in-lbs (N-m)	24600 (2780)	28600 (3230)	31300 (3540)	31300 (3540)	31300 (3540)	31300 (3540)	31300 (3540)	31300 (3540)	31300 (3540)	31300 (3540)	31300 (3540)	31300 (3540)	31300 (3540)	
Input Power HP (kW)	2.73 (2.04)	2.35 (1.75)	1.99 (1.48)	1.72 (1.28)	1.46 (1.09)	1.23 (0.917)	1.04 (0.776)	0.890 (0.664)	0.753 (0.562)	0.600 (0.448)	0.508 (0.379)	0.438 (0.326)	0.388 (0.290)	C614DC
Output Torque in-lbs (N-m)	31300 (3540)	31300 (3540)	31300 (3540)	31300 (3540)	31300 (3540)	31300 (3540)	31300 (3540)	31300 (3540)	31300 (3540)	31300 (3540)	31300 (3540)	31300 (3540)	31300 (3540)	
Input Power HP (kW)	2.14 (1.60)	2.14 (1.60)	2.14 (1.60)	2.14 (1.60)	2.14 (1.60)	2.13 (1.59)	1.80 (1.35)	1.54 (1.15)	1.31 (0.975)	1.04 (0.777)	0.881 (0.657)	0.759 (0.566)	0.674 (0.503)	D616DA
Output Torque in-lbs (N-m)	24600 (2780)	28600 (3230)	33800 (3820)	39000 (4410)	46100 (5210)	54300 (6140)	54300 (6140)	54300 (6140)	54300 (6140)	54300 (6140)	54300 (6140)	54300 (6140)	54300 (6140)	
Input Power HP (kW)	4.50 (3.36)	4.07 (3.04)	3.44 (2.57)	2.98 (2.23)	2.53 (1.88)	2.13 (1.59)	1.80 (1.35)	1.54 (1.15)	1.31 (0.975)	1.04 (0.777)	0.881 (0.657)	0.759 (0.566)	0.674 (0.503)	D616DB
Output Torque in-lbs (N-m)	51600 (5830)	54300 (6140)	54300 (6140)	54300 (6140)	54300 (6140)	54300 (6140)	54300 (6140)	54300 (6140)	54300 (6140)	54300 (6140)	54300 (6140)	54300 (6140)	54300 (6140)	
Input Power HP (kW)	4.74 (3.53)	4.07 (3.04)	3.44 (2.57)	2.98 (2.23)	2.53 (1.88)	2.13 (1.59)	1.80 (1.35)	1.54 (1.15)	1.31 (0.975)	1.04 (0.777)	0.881 (0.657)	0.759 (0.566)	0.674 (0.503)	D616DC
Output Torque in-lbs (N-m)	54300 (6140)	54300 (6140)	54300 (6140)	54300 (6140)	54300 (6140)	54300 (6140)	54300 (6140)	54300 (6140)	54300 (6140)	54300 (6140)	54300 (6140)	54300 (6140)	54300 (6140)	
Input Power HP (kW)	2.14 (1.60)	2.14 (1.60)	2.14 (1.60)	2.14 (1.60)	2.14 (1.60)	2.14 (1.60)	2.14 (1.60)	2.14 (1.60)	1.82 (1.36)	1.45 (1.08)	1.23 (0.917)	1.06 (0.790)	0.940 (0.701)	E617DA
Output Torque in-lbs (N-m)	24600 (2780)	28600 (3230)	33800 (3820)	39000 (4410)	46100 (5210)	54600 (6170)	64600 (7300)	75500 (8530)	75900 (8570)	75900 (8570)	75900 (8570)	75900 (8570)	75900 (8570)	
Input Power HP (kW)	4.50 (3.36)	4.50 (3.36)	4.50 (3.36)	4.17 (3.11)	3.53 (2.63)	2.98 (2.22)	2.52 (1.88)	2.15 (1.61)	1.82 (1.36)	1.45 (1.08)	1.23 (0.917)	1.06 (0.790)	0.940 (0.701)	E617DB
Output Torque in-lbs (N-m)	51600 (5830)	60100 (6790)	71000 (8020)	75900 (8570)	75900 (8570)	75900 (8570)	75900 (8570)	75900 (8570)	75900 (8570)	75900 (8570)	75900 (8570)	75900 (8570)	75900 (8570)	
Input Power HP (kW)	6.61 (4.93)	5.68 (4.24)	4.81 (3.59)	4.17 (3.11)	3.53 (2.63)	2.98 (2.22)	2.52 (1.88)	2.15 (1.61)	1.82 (1.36)	1.45 (1.08)	1.23 (0.917)	1.06 (0.790)	0.940 (0.701)	E617DC
Output Torque in-lbs (N-m)	75900 (8570)	75900 (8570)	75900 (8570)	75900 (8570)	75900 (8570)	75900 (8570)	75900 (8570)	75900 (8570)	75900 (8570)	75900 (8570)	75900 (8570)	75900 (8570)	75900 (8570)	

Notes: * Minimum motor power for starting in cold temperature or high inertia application. A torque limiting device is recommended to protect the unit or driven machine.

Double Reduction Selection Tables

1750 RPM - Quill, C-Face, and Free Input

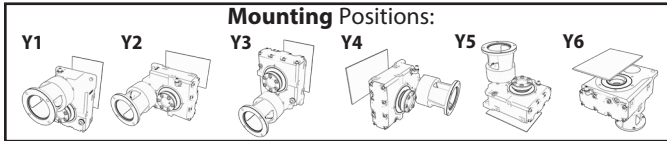

Single Reduction Selection Tables

Y1, Y2, Y3, Y4: Pages 2.8 - 2.9

Y5, Y6: Pages 2.10 - 2.11

Double Reduction Selection Tables

Y1, Y2, Y3, Y4, Y5, Y6: Pages 2.12 - 2.13

C-Face Dimensions Pages:

Single Reduction 2.14-2.15

Double Reduction 2.16-2.218

Quill Dimensions Pages:

Single Reduction 2.19

Double Reduction 2.20

Output RPM	0.595	0.499	0.401	0.338	0.270	0.242	0.197	0.164	0.144	0.113	0.0974	0.0809	0.0661	Frame Size
Ratio	2944	3511	4365	5177	6472	7228	8880	10658	12184	15530	17966	21620	26492	
Input Power HP (kW)	1/8* (0.1)*	1/8* (0.1)*	1/8* (0.1)*	1/8* (0.1)*	1/8* (0.1)*	1/8* (0.1)*	1/8* (0.1)*	1/8* (0.1)*	1/8* (0.1)*	1/8* (0.1)*	1/8* (0.1)*			Z609DA
Output Torque in-lbs (N-m)	3870 (437)	3870 (437)	3870 (437)	3870 (437)	3870 (437)	3870 (437)	3870 (437)	3870 (437)	3870 (437)	3870 (437)	3870 (437)			
Input Power HP (kW)	1/8* (0.1)*	1/8* (0.1)*	1/8* (0.1)*	1/8* (0.1)*	1/8* (0.1)*	1/8* (0.1)*	1/8* (0.1)*	1/8* (0.1)*	1/8* (0.1)*	1/8* (0.1)*	1/8* (0.1)*			A610DA
Output Torque in-lbs (N-m)	7820 (884)	7820 (884)	7820 (884)	7820 (884)	7820 (884)	7820 (884)	7820 (884)	7820 (884)	7820 (884)	7820 (884)	7820 (884)			
Input Power HP (kW)	0.169 (0.126)	0.142 (0.106)	1/8* (0.1)*	1/8* (0.1)*	1/8* (0.1)*	1/8* (0.1)*	1/8* (0.1)*	1/8* (0.1)*	1/8* (0.1)*	1/8* (0.1)*	1/8* (0.1)*			B612DA
Output Torque in-lbs (N-m)	15700 (1770)	15700 (1770)	15700 (1770)	15700 (1770)	15700 (1770)	15700 (1770)	15700 (1770)	15700 (1770)	15700 (1770)	15700 (1770)	15700 (1770)			
Input Power HP (kW)	0.169 (0.126)	0.142 (0.106)	1/8* (0.1)*	1/8* (0.1)*	1/8* (0.1)*	1/8* (0.1)*	1/8* (0.1)*	1/8* (0.1)*	1/8* (0.1)*	1/8* (0.1)*	1/8* (0.1)*	1/8* (0.1)*	1/8* (0.1)*	B612DB
Output Torque in-lbs (N-m)	15700 (1770)	15700 (1770)	15700 (1770)	15700 (1770)	15700 (1770)	15700 (1770)	15700 (1770)	15700 (1770)	15700 (1770)	15700 (1770)	15700 (1770)	15700 (1770)	15700 (1770)	
Input Power HP (kW)	0.338 (0.252)	0.283 (0.211)	1/4* (0.2)*	1/4* (0.2)*	1/4* (0.2)*	1/4* (0.2)*	1/4* (0.2)*	1/4* (0.2)*	1/4* (0.2)*	1/4* (0.2)*	1/4* (0.2)*			C614DA
Output Torque in-lbs (N-m)	31300 (3540)	31300 (3540)	31300 (3540)	31300 (3540)	31300 (3540)	31300 (3540)	31300 (3540)	31300 (3540)	31300 (3540)	31300 (3540)	31300 (3540)			
Input Power HP (kW)	0.338 (0.252)	0.283 (0.211)	1/4* (0.2)*	1/4* (0.2)*	1/4* (0.2)*	1/4* (0.2)*	1/4* (0.2)*	1/4* (0.2)*	1/4* (0.2)*	1/4* (0.2)*	1/4* (0.2)*	1/4* (0.2)*	1/4* (0.2)*	C614DB
Output Torque in-lbs (N-m)	31300 (3540)	31300 (3540)	31300 (3540)	31300 (3540)	31300 (3540)	31300 (3540)	31300 (3540)	31300 (3540)	31300 (3540)	31300 (3540)	31300 (3540)	31300 (3540)	31300 (3540)	
Input Power HP (kW)	0.338 (0.252)	0.283 (0.211)	1/4* (0.2)*	1/4* (0.2)*	1/4* (0.2)*	1/4* (0.2)*	1/4* (0.2)*	1/4* (0.2)*	1/4* (0.2)*	1/4* (0.2)*	1/4* (0.2)*	1/4* (0.2)*	1/4* (0.2)*	C614DC
Output Torque in-lbs (N-m)	31300 (3540)	31300 (3540)	31300 (3540)	31300 (3540)	31300 (3540)	31300 (3540)	31300 (3540)	31300 (3540)	31300 (3540)	31300 (3540)	31300 (3540)	31300 (3540)	31300 (3540)	
Input Power HP (kW)	0.586 (0.437)	1/2* (0.4)*	1/2* (0.4)*	1/2* (0.4)*	1/2* (0.4)*	1/4* (0.2)*	1/4* (0.2)*	1/4* (0.2)*	1/4* (0.2)*	1/4* (0.2)*	1/4* (0.2)*	1/4* (0.2)*	1/4* (0.2)*	D616DA
Output Torque in-lbs (N-m)	54300 (6140)	54300 (6140)	54300 (6140)	54300 (6140)	54300 (6140)	54300 (6140)	54300 (6140)	54300 (6140)	54300 (6140)	54300 (6140)	54300 (6140)	54300 (6140)	54300 (6140)	
Input Power HP (kW)	0.586 (0.437)	1/2* (0.4)*	1/2* (0.4)*	1/2* (0.4)*	1/2* (0.4)*	1/4* (0.2)*	1/4* (0.2)*	1/4* (0.2)*	1/4* (0.2)*	1/4* (0.2)*	1/4* (0.2)*	1/4* (0.2)*	1/4* (0.2)*	D616DB
Output Torque in-lbs (N-m)	54300 (6140)	54300 (6140)	54300 (6140)	54300 (6140)	54300 (6140)	54300 (6140)	54300 (6140)	54300 (6140)	54300 (6140)	54300 (6140)	54300 (6140)	54300 (6140)	54300 (6140)	
Input Power HP (kW)	0.586 (0.437)	1/2* (0.4)*	1/2* (0.4)*	1/2* (0.4)*	1/2* (0.4)*	1/4* (0.2)*	1/4* (0.2)*	1/4* (0.2)*	1/4* (0.2)*	1/4* (0.2)*	1/4* (0.2)*	1/4* (0.2)*	1/4* (0.2)*	D616DC
Output Torque in-lbs (N-m)	54300 (6140)	54300 (6140)	54300 (6140)	54300 (6140)	54300 (6140)	54300 (6140)	54300 (6140)	54300 (6140)	54300 (6140)	54300 (6140)	54300 (6140)	54300 (6140)	54300 (6140)	
Input Power HP (kW)	0.817 (0.610)	0.685 (0.511)	0.551 (0.411)	1/2* (0.4)*	1/2* (0.4)*	1/2* (0.4)*	1/2* (0.4)*	1/4* (0.2)*	1/4* (0.2)*	1/4* (0.2)*	1/4* (0.2)*	1/4* (0.2)*	1/4* (0.2)*	E617DA
Output Torque in-lbs (N-m)	75900 (8570)	75900 (8570)	75900 (8570)	75900 (8570)	75900 (8570)	75900 (8570)	75900 (8570)	75900 (8570)	75900 (8570)	75900 (8570)	75900 (8570)	75900 (8570)	75900 (8570)	
Input Power HP (kW)	0.817 (0.610)	0.685 (0.511)	0.551 (0.411)	1/2* (0.4)*	1/2* (0.4)*	1/2* (0.4)*	1/2* (0.4)*	1/4* (0.2)*	1/4* (0.2)*	1/4* (0.2)*	1/4* (0.2)*	1/4* (0.2)*	1/4* (0.2)*	E617DB
Output Torque in-lbs (N-m)	75900 (8570)	75900 (8570)	75900 (8570)	75900 (8570)	75900 (8570)	75900 (8570)	75900 (8570)	75900 (8570)	75900 (8570)	75900 (8570)	75900 (8570)	75900 (8570)	75900 (8570)	
Input Power HP (kW)	0.817 (0.610)	0.685 (0.511)	0.551 (0.411)	1/2* (0.4)*	1/2* (0.4)*	1/2* (0.4)*	1/2* (0.4)*	1/4* (0.2)*	1/4* (0.2)*	1/4* (0.2)*	1/4* (0.2)*	1/4* (0.2)*	1/4* (0.2)*	E617DC
Output Torque in-lbs (N-m)	75900 (8570)	75900 (8570)	75900 (8570)	75900 (8570)	75900 (8570)	75900 (8570)	75900 (8570)	75900 (8570)	75900 (8570)	75900 (8570)	75900 (8570)	75900 (8570)	75900 (8570)	

Cyclo® HBB

Selection Tables

Notes: * Minimum motor power for starting in cold temperature or high inertia application. A torque limiting device is recommended to protect the unit or driven machine.

C-Face Dimensions

Single Reduction

EHY(J)-Z6090Y~E6175Y

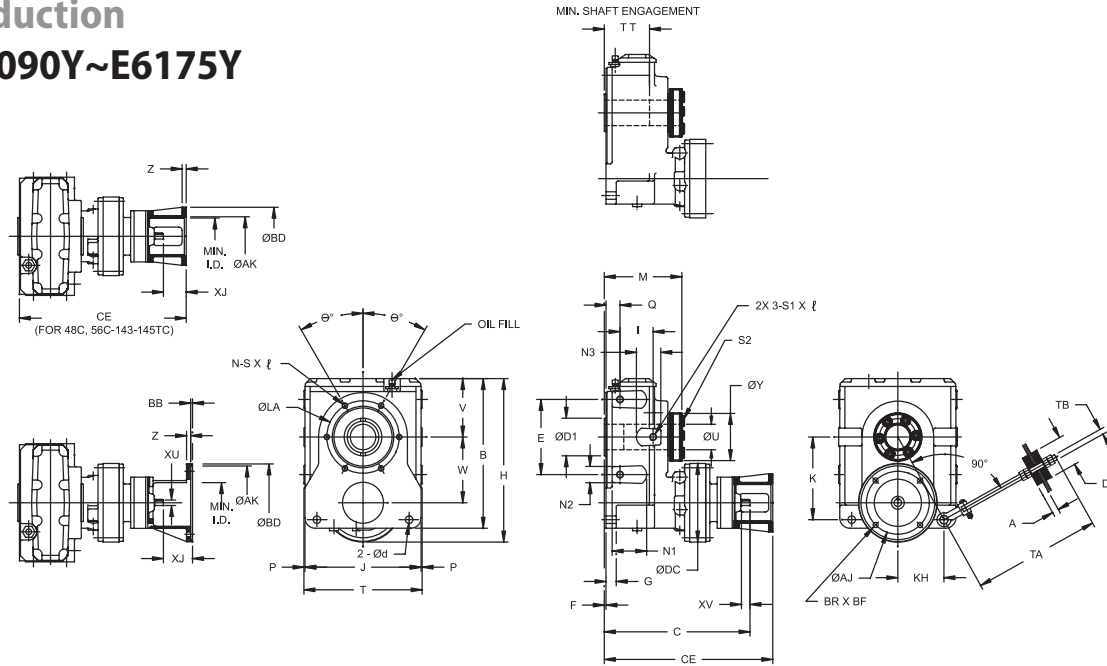

Cyclo® HBB All dimensions are in inches (mm).

Dimensions

Model	B	C	E	F	G	H	I	J	K	M	P	Q	T	TT	ØU	
															Max (Std)	Min
Z609	11.00 (279.5)	9.09 (231)	5.51 (140)	0.20 (5)	0.79 (20)	11.87 (301)	2.20 (56)	8.31 (211)	6.18 (157)	6.06 (154)	0.12 (3)	1.06 (27)	8.54 (217)	4.43 (113)	1-7/16 (36.5)	1-3/16 (30.2)
A610	11.83 (300.5)	9.92 (252)	5.91 (150)			12.70 (323)	2.60 (66)	9.17 (233)	6.44 (163.5)	6.61 (168)		1.14 (29)	9.41 (239)	4.96 (126)	2-3/16 (55.6)	1-11/16 (42.9)
B612	14.45 (367)	12.03 (306)	7.48 (190)		0.98 (35)	16.10 (409)	3.39 (86)	11.42 (290)	7.97 (202.5)	7.64 (194)		1.22 (31)	11.65 (296)	5.63 (143)	2-7/16 (61.9)	1-15/16 (49.2)
C614	17.24 (438)	14.86 (377)	8.66 (220)		1.18 (30)	18.84 (479)	3.82 (97)	13.39 (340)	9.53 (242)	9.17 (233)		1.61 (41)	13.62 (346)	7.32 (186)	2-15/16 (74.6)	2-3/16 (55.6)
D616	21.22 (539)	17.87 (454)	9.84 (250)	0.28 (7)	1.38 (35)	23.94 (608)	4.49 (114)	16.77 (426)	11.54 (293)	10.20 (259)	0.20 (5)	1.77 (45)	17.17 (436)	8.03 (204)	3-7/16 (87.3)	2-7/16 (65.1)
E617	24.02 (610)	20.00 (508)	11.81 (300)		1.77 (45)	26.85 (682)	5.00 (127)	18.90 (480)	13.07 (332)	10.98 (279)		1.97 (50)	19.29 (490)	8.82 (224)	3-15/16 (100)	2-15/16 (74.6)

Model	V	W	ØY	Ød	ØD1	ØDC	KH	N1	N2	N3	S2	TA	A	D	TB
Z609	4.23 (107.5)	4.69 (119)	3.23 (82)	0.55 (14)	2.56 (65)	5.91 (150)	3.54 (90)	1.02 (26)	1.02 (26)	-	M10	17.50 (445)	0.63 (16)	2.36 (60)	M20
A610	4.61 (117)	5.14 (131)	4.09 (104)	0.71 (18)	3.35 (85)	3.74 (95)	1.10 (28)	1.10 (28)	M12		17.87 (454)				
B612	5.69 (144.5)	6.40 (163)	4.49 (114)		3.94 (100)	8.03 (204)	4.33 (110)	1.34 (34)	1.26 (32)		M16	18.37 (467)			
C614	6.73 (171)	7.58 (193)	5.43 (138)	0.87 (22)	4.33 (110)	9.06 (230)	5.31 (135)	3.98 (101)	2.05 (52)	2.83 (72)	M16	19.50 (495)	0.75 (19)	3.54 (90)	M24
D616	8.43 (214)	9.61 (244)	5.98 (152)	1.02 (26)	5.12 (130)	11.81 (300)	6.38 (162)	3.62 (92)	2.36 (60)	3.62 (92)		20.25 (514)			
E617	9.45 (240)	10.71 (272)	6.69 (170)	1.30 (33)	5.91 (150)	13.39 (340)	7.09 (180)	3.82 (97)	2.44 (62)	3.94 (100)					

C-Face Dimensions

Single Reduction EHY(J)-Z6090Y~E6175Y

All dimensions are in inches.

Model	ØL	Ø°	N	S x L	S1 x L	XU	XV	Key	Wt. lb (kg)			
Z609	4.72 (120)	0	4	M10x0.79 (M10x20)	M10x0.79 (M10x20)	0.625 (16)	0.98 (25)	3/16 x 3/16 x 0.75 (4.762 x 4.762 x 19)	62 (28)			
A610	6.10 (155)	30	6		M12x0.87 (M12x22)				M12x0.87 (M12x22)	0.750 (19)	1.38 (35)	3/16 x 3/16 x 1.02 (4.762 x 4.762 x 26)
B612	6.89 (175)			M16x1.02 (M16x26)	M16x1.02 (M16x26)	0.875 (22)	1.57 (40)	3/16 x 3/16 x 1.38 (4.762 x 4.762 x 35)	154 (70)			
C614	8.35 (212)			M16x1.18 (M16x30)	M20x1.38 (M20x35)				1.125 (29)			
D616	10.04 (255)			M20x1.38 (M20x35)	M24x1.57 (M24x40)	1.375 (35)	2.17 (55)	5/16 x 5/16 x 2.17 (7.9375 x 7.9375 x 55)				
E617	11.02 (280)	22.5	8								626 (284)	

Model	NEMA C-Face	ØAJ	ØAK	ØBD	BB	BF	BR	CE	XJ	Z	Min. ID	Wt. lb (kg)	
Z609	42C	3.75 (95)	3.00 (76)	4.33 (110)	-	0.28 (7)	-	10.87 (276)	1.78 (45)	-	2.44 (62)	68 (31)	
	48C							11.25 (286)	2.16 (55)				
	56-145TC	5.87 (149)	4.50 (114)	6.69 (170)		0.43 (11)		11.72 (298)	2.63 (67)		4.21 (107)	70 (32)	
A610	48C	3.75 (95)	3.00 (76)	4.33 (110)	0.22 (6)	0.28 (7)	4	12.08 (307)	2.16 (55)	0.47 (12)	2.44 (62)	90 (41)	
	56-145TC	5.87 (149)	4.50 (114)	6.69 (170)		0.43 (11)		12.55 (319)	2.63 (67)		4.21 (107)	92 (42)	
	182-184TC	7.25 (184)	8.50 (216)	8.98 (228)		0.55 (14)		13.37 (340)	3.45 (88)		5.43 (138)	96 (44)	
B612	56-145TC	5.87 (149)	4.50 (114)	6.69 (170)	-	0.43 (11)	-	14.65 (372)	2.63 (67)	-	4.21 (107)	163 (74)	
	182-184TC	7.25 (184)	8.50 (216)	8.98 (228)		0.22 (6)		0.55 (14)	15.40 (391)		3.37 (86)	5.43 (138)	176 (80)
	213-215TC								16.40 (417)		4.37 (111)	1.47 (37)	266 (121)
C614	56-145TC	5.87 (149)	4.50 (114)	6.69 (170)	0.22 (6)	0.43 (11)	4	17.49 (444)	2.63 (67)	0.47 (12)	4.21 (107)	266 (121)	
	182-184TC	7.25 (184)	8.50 (216)	8.98 (228)		0.59 (15)		18.24 (463)	3.37 (86)		5.43 (138)	270 (122)	
	213-215TC							19.24 (489)	4.37 (111)		1.47 (37)	279 (127)	
	254-256TC							19.79 (503)	4.93 (125)		0.57 (14)	500 (227)	
D616	56-145TC	5.87 (149)	4.50 (114)	6.69 (170)	0.22 (6)	0.43 (11)	-	20.50 (521)	2.63 (267)	0.47 (12)	4.21 (107)	500 (227)	
	182-184TC	7.25 (184)	8.50 (216)	8.98 (228)		0.55 (14)		21.25 (540)	3.37 (86)		0.57 (14)	505 (229)	
	213-215TC							21.87 (555)	4.00 (102)		1.20 (30)	511 (232)	
	254-256TC							22.63 (575)	4.75 (121)		0.57 (14)	507 (230)	
	284-286TC							9.00 (229)	10.50 (267)			11.10 (282)	23.65 (601)
E617	182-184TC	7.25 (184)	8.50 (216)	8.98 (228)	0.22 (6)	0.55 (14)	-	23.38 (594)	3.38 (86)	-	5.71 (145)	670 (304)	
	213-215TC							24.00 (610)	4.00 (102)			1.20 (30)	676 (307)
	254-256TC							24.75 (629)	4.75 (121)			0.57 (14)	672 (305)
	284-286TC							9.00 (229)	10.50 (267)			11.10 (282)	25.44 (646)
	324-326TC	11.00 (279)	12.50 (318)	14.17 (360)				0.71 (18)	26.00 (660)		6.00 (152)	0.57 (14)	697 (316)

Cyclo® HBB

Dimensions

C-Face Dimensions

Double Reduction

EHY(J)-Z6090DAY~E6175DCY

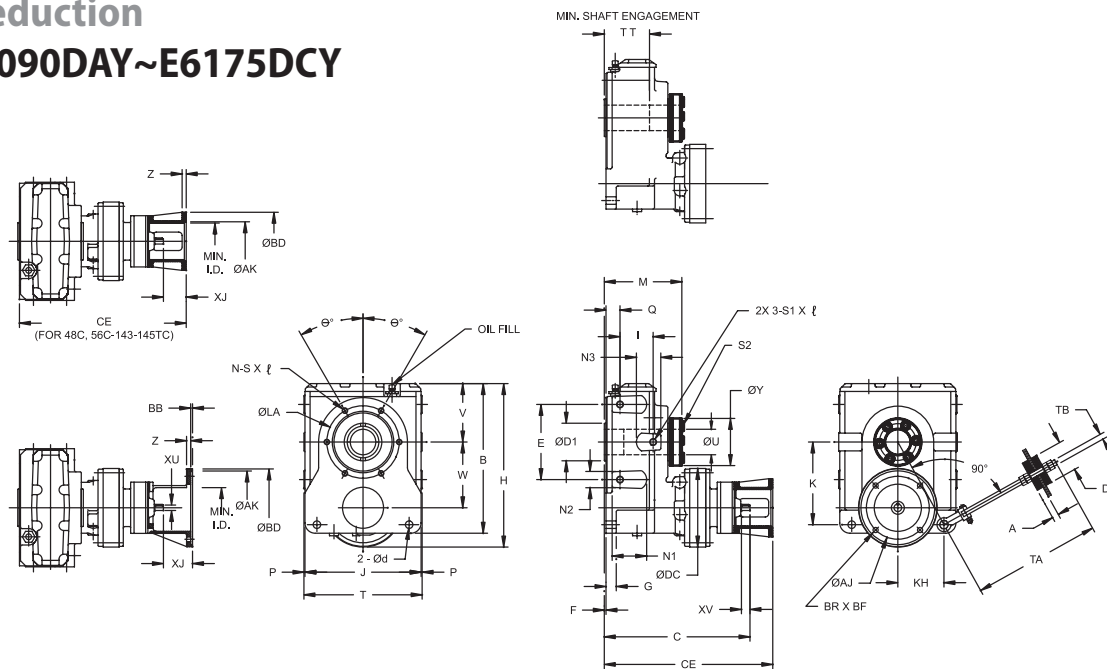

Cyclo® HBB

Dimensions

All dimensions are in inches (mm).

Model	B	C	E	F	G	H	I	J	K	M	P	Q	T	TT	ØU	
															Max (Std)	Min
Z609DA	11.00 (279.5)	10.73 (273)	5.51 (140)	0.20 (5)	0.79 (20)	11.87 (301)	2.20 (56)	8.31 (211)	6.18 (157)	6.06 (154)	0.12 (3)	1.06 (27)	8.54 (217)	4.43 (113)	1-7/16 (36.5)	1-3/16 (30.2)
A610DA	11.83 (300.5)	11.87 (301)	5.91 (150)			12.70 (323)	2.60 (66)	9.17 (233)	6.44 (163.5)	6.61 (168)		1.14 (29)	9.41 (239)	4.96 (126)	2-3/16 (55.6)	1-11/16 (42.9)
B612DA	14.45 (367)	13.37 (340)	7.48 (190)			0.98 (25)	16.10 (409)	3.39 (86)	11.42 (290)	7.97 (202)		7.64 (194)	1.22 (31)	11.65 (296)	5.63 (143)	2-7/16 (61.9)
B612DB		14.10 (358)		0.28 (7)	1.18 (30)	18.84 (479)	3.82 (97)	13.39 (340)	9.53 (242)	9.17 (233)	0.20 (5)	1.61 (41)	13.62 (346)	7.32 (186)	2-15/16 (74.6)	2-3/16 (55.6)
C614DA		15.91 (404)														
C614DB	17.24 (438)	16.54 (420)	8.66 (220)													
C614DC		16.78 (426)														
D616DA	21.22 (539)	18.68 (474)	9.84 (250)	0.28 (7)	1.38 (35)	23.94 (608)	4.49 (114)	16.77 (426)	11.54 (293)	10.20 (259)	0.20 (5)	1.77 (45)	17.17 (436)	8.03 (204)	3-7/16 (87.3)	2-7/16 (61.9)
D616DB		18.92 (481)														
D616DC		19.80 (503)														
E617DA	24.02 (610)	20.06 (510)	11.81 (300)	0.28 (7)	1.77 (45)	26.85 (682)	5.00 (127)	18.90 (480)	13.07 (332)	10.98 (279)	0.20 (5)	1.97 (50)	19.29 (490)	8.82 (224)	3-15/16 (100)	2-15/16 (74.6)
E617DB		20.30 (516)														
E617DC		21.26 (540)														

C-Face Dimensions

Double Reduction EHY(J)-Z6090DAY~E6175DCY

All dimensions are in inches (mm).

Model	V	W	ØY	Ød	ØD1	ØDC	KH	N1	N2	N3	S2	TA	A	D	TB
Z609DA	4.23 (107.4)	4.69 (119)	3.23 (82)	0.55 (14)	2.56 (65)	5.91 (150)	3.54 (90)	1.02 (26)	1.02 (26)	-	M10	17.50 (445)	0.63 (16)	2.36 (60)	M20
A610DA	4.61 (117)	5.14 (131)	4.09 (104)	0.71 (18)	3.35 (85)		3.74 (95)	1.10 (28)	1.10 (28)						
B612DA	5.69 (144.5)	6.40 (163)	4.49 (114)		3.94 (100)	8.03 (204)	4.33 (110)	1.34 (32)	1.26 (32)		M12	17.87 (454)			
C614DA	6.73 (171)	7.58 (193)	5.43 (138)	0.87 (22)	4.33 (110)	9.06 (230)	5.31 (135)	3.98 (52)	2.05 (52)	2.83 (72)	18.37 (467)	0.75 (19)	3.54 (90)	M24	
C614DB															
C614DC															
D616DA	8.43 (214)	9.61 (244)	5.98 (152)	1.02 (26)	5.12 (130)	11.81 (300)	6.38 (162)	3.62 (60)	2.36 (60)	3.62 (92)	19.50 (495)	0.75 (19)	3.54 (90)	M24	
D616DB															
D616DC															
E617DA	9.45 (240)	10.71 (272)	6.69 (170)	1.30 (33)	5.91 (150)	13.39 (340)	7.09 (180)	3.82 (62)	2.44 (62)	3.94 (100)	20.25 (514)	0.75 (19)	3.54 (90)	M24	
E617DB															
E617DC															

Cydo® HBB

Dimensions

All dimensions are in inches (mm).

Model	ØLA	Ø°	N	S x L	S1 x L	XU	XV	Key	Wt. lb (kg)				
Z609DA	4.72 (120)	0	4	M10x0.79 (M10x20)	M10x0.79 (M10x20)	0.500 (13)	0.98 (25)	1/8 x 1/8 x 0.71 (3.175 x 3.175 x 18)	65 (29)				
A610DA	6.10 (155)				M12x0.87 (M12x22)				90 (41)				
B612DA	6.89 (175)			M12x0.87 (M12x22)	M16x1.02 (M16x26)			158 (72)					
B612DB								3/16 x 3/16 x 0.75 (4.762 x 4.762 x 19)	165 (75)				
C614DA	8.35 (212)			30	6			M16x1.18 (M16x30)	M20x1.38 (M20x35)	0.625 (16)	0.98 (25)	1/8 x 1/8 x 0.71 (3.175 x 3.175 x 18)	247 (112)
C614DB												256 (116)	
C614DC												258 (117)	
D616DA	10.04 (255)			30	6			M16x1.18 (M16x30)	M20x1.38 (M20x35)	0.625 (16)	0.98 (25)	3/16 x 3/16 x 0.75 (4.762 x 4.762 x 19)	461 (209)
D616DB												465 (211)	
D616DC												481 (218)	
E617DA	11.02 (280)	22.5	8	M20x1.38 (M20x35)	M24x1.57 (M24x40)	0.750 (19)	1.38 (35)	3/16 x 3/16 x 1.02 (4.762 x 4.762 x 26)	612 (278)				
E617DB								622 (282)					
E617DC								633 (287)					

C-Face Dimensions

Double Reduction

EHY(J)-Z6090DAY~E6175DCY

Model	NEMA C-Face	ØAJ	ØAK	ØBD	BB	BF	BR	CE	XJ	Z	Min. ID	Wt. lb (kg)
Z609DA	42C	3.75 (95)	3.00 (76)	4.33 (110)		0.28 (7)		12.51 (318)	1.78 (45)	0.47 (12)	2.44 (62)	68 (31)
	48C							12.89 (327)	2.16 (55)			
	56C	5.87 (149)	4.50 (114)	6.69 (170)		0.43 (11)		13.29 (338)	2.56 (65)		3.15 (80)	70 (32)
A610DA	42C	3.75 (85)	3.00 (76)	4.33 (110)		0.28 (7)		13.65 (347)	1.78 (45)	0.47 (12)	2.44 (62)	93 (42)
	48C							14.03 (356)	2.16 (55)			
	56C	5.87 (149)	4.50 (114)	6.69 (170)		0.43 (11)		14.43 (367)	2.56 (65)		3.15 (80)	95 (43)
B612DA	42C	3.75 (95)	3.00 (76)	4.33 (110)		0.28 (7)		15.15 (385)	1.78 (45)	0.47 (12)	2.44 (62)	161 (73)
	48C							15.53 (394)	2.16 (55)			
	56C	5.87 (149)	4.50 (114)	6.69 (170)		0.43 (11)		15.93 (405)	2.56 (65)		3.15 (80)	164 (74)
B612DB	48C	3.75 (95)	3.00 (76)	4.33 (110)		0.28 (7)		16.26 (413)	2.16 (55)	0.47 (12)	2.44 (62)	170 (77)
	56C~145TC	5.87 (149)	4.50 (114)	6.69 (170)		0.43 (11)		16.73 (425)	2.63 (67)		4.21 (107)	172 (78)
C614DA	48C	3.75 (95)	3.00 (76)	4.33 (110)				0.28 (7)			18.07 (459)	2.16 (55)
	56C	5.87 (149)	4.50 (114)	6.69 (170)	0.43 (11)		18.47 (469)	2.56 (65)		3.15 (80)	253 (115)	
C614DB	48C	3.75 (95)	3.00 (76)	4.33 (110)			0.28 (7)			18.70 (475)	2.16 (55)	0.47 (12)
	56C~145TC	5.87 (149)	4.50 (114)	6.69 (170)		0.43 (11)	19.17 (487)		2.63 (67)	4.21 (107)	264 (120)	
C614DC	56~145TC									19.41 (493)		
	182~184TC	7.25 (184)	8.50 (216)	8.98 (228)	0.22 (6)		0.55 (14)	20.23 (514)		3.45 (88)	5.43 (138)	269 (122)
D616DA	56C~145TC	5.87 (149)	4.50 (114)	6.69 (170)			0.43 (11)			21.31 (541)	2.63 (67)	0.47 (12)
D616DB	56C~145TC						21.55 (547)				472 (214)	
	182~184TC	7.25 (184)	8.50 (216)	8.98 (228)		0.55 (14)	22.37 (568)		3.45 (88)	5.43 (138)	476 (216)	
D616DC	56~145TC	5.87 (149)	4.50 (114)	6.69 (170)		0.43 (11)		22.43 (570)	2.63 (67)	0.47 (12)	4.21 (107)	490 (222)
	182~184TC	7.25 (184)	8.50 (216)	8.98 (228)		0.22 (6)		0.55 (14)	23.17 (589)		3.37 (86)	5.43 (138)
E617DA	56C~145TC	5.87 (149)	4.50 (114)	6.69 (170)				0.43 (11)			22.69 (576)	2.63 (67)
E617DB	56C~145TC						22.93 (582)	2.63 (67)			629 (285)	
	182~184TC	7.25 (184)	8.50 (216)	8.98 (228)	0.22 (6)		0.55 (14)	23.75 (603)		3.45 (88)	5.43 (138)	633 (287)
E617DC	182~184TC							24.63 (626)	3.37 (86)	0.47 (12)		646 (293)

Cydo® HBB

Dimensions

Quill Hollow Input Dimensions

Single Reduction EHY(X)-Z6090Y~D6165Y

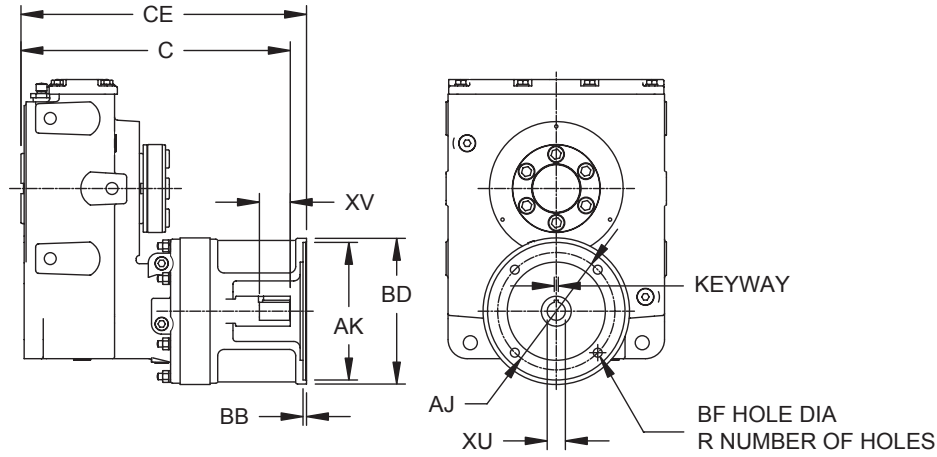

All dimensions are in inches. (mm)

Cyclo® HBB

Model	NEMA C-Face	ØAJ	ØAK	ØBD	BB	BF	BR(R)	C	CE	XU	XU Tol.	XV	Keyway	Wt. lb (kg)
Z609	56C	5.87 (149.1)	4.50 (114.3)	6.69 (170.0)	-	0.43 (11.0)	4	9.06 (230.2)	10.09 (256.3)	0.625 (15.9)	0.0014 / 0.0007 (0.034 / 0.016)	1.18 (30.0)	3/16 x 3/32 (4.762 x 2.381)	68 (31)
	143-145TC							9.47 (240.6)	0.875 (22.3)	0.0016 / 0.0008 (0.041 / 0.020)	1.57 (39.9)			
A610	56C	5.87 (149.1)	4.50 (114.3)	6.69 (170.0)	-	0.43 (11.0)	4	9.97 (253.3)	11.03 (280.2)	0.625 (15.9)	0.0014 / 0.0007 (0.034 / 0.016)	1.18 (30.0)	3/16 x 3/32 (4.762 x 2.381)	92 (42)
	143-145TC							10.44 (265.2)	0.875 (22.3)	0.0016 / 0.0008 (0.041 / 0.020)	1.65 (42.0)			
	182-184TC							7.25 (184.2)	8.50 (215.9)	8.98 (228.1)	0.22 (5.6)	0.55 (14.0)	11.38 (289.1)	12.19 (309.7)
B612	56C	5.87 (149.1)	4.50 (114.3)	6.69 (170.0)	-	0.43 (11.0)	4	12.08 (302.9)	13.14 (333.8)	0.625 (15.9)	0.0014 / 0.0007 (0.034 / 0.016)	1.18 (30.0)	3/16 x 3/32 (4.762 x 2.381)	162 (73)
	143-145TC							12.27 (311.7)	0.875 (22.3)	0.0016 / 0.0008 (0.041 / 0.020)	1.50 (38.1)			
	182-184TC							13.37 (339.6)	14.06 (357.2)	1.125 (28.6)	0.0016 / 0.0008 (0.041 / 0.020)	2.48 (63.0)	1/4 x 1/8 (6.35 x 3.175)	165 (75)
	213-215TC							13.49 (342.7)	1.375 (35.0)	0.002 / 0.001 (0.050 / 0.025)	2.64 (67.1)	5/16 x 5/32 (7.938 x 3.969)	164 (74)	
C614	143-145TC	5.87 (149.1)	4.50 (114.3)	6.69 (170.0)	-	0.43 (11.0)	4	15.19 (385.9)	15.74 (399.8)	0.875 (22.3)	0.0016 / 0.0008 (0.041 / 0.020)	1.61 (40.9)	3/16 x 3/32 (4.762 x 2.381)	263 (119)
	182-184TC							16.64 (422.7)	1.125 (28.6)	0.0016 / 0.0008 (0.041 / 0.020)	1.91 (48.6)	1/4 x 1/8 (6.35 x 3.175)	271 (123)	
	213-215TC							16.29 (413.8)	17.43 (442.8)	1.375 (35.0)	0.002 / 0.001 (0.050 / 0.025)	2.68 (68.1)	5/16 x 5/32 (7.938 x 3.969)	270 (122)
	254-256TC							16.60 (421.7)	1.625 (41.3)	0.002 / 0.001 (0.050 / 0.025)	2.99 (76.0)	3/8 x 3/16 (9.525 x 4.762)	271 (123)	
D616	182-184TC	7.25 (184.2)	8.50 (215.9)	8.98 (228.1)	0.22 (5.6)	0.55 (14.0)	4	18.06 (458.8)	18.78 (477.1)	1.125 (28.6)	0.0016/0.0008 (0.041 / 0.020)	2.01 (51.1)	1/4 x 1/8 (6.35 x 3.175)	468 (212)
	213-215TC									1.375 (35.0)	0.002 / 0.001 (0.050 / 0.025)	3.11 (79.0)	5/16 x 5/32 (7.938 x 3.969)	467 (212)
	254-256TC									1.625 (41.3)	0.002 / 0.001 (0.050 / 0.025)	3.11 (79.0)	3/8 x 3/16 (9.525 x 4.762)	466 (211)

Dimensions

Quill Hollow Input Dimensions

Double Reduction

EHY(X)-Z6090DAY~E6175DCY

Cydo® HBB
Dimensions

Model	NEMA C-Face		ØAJ	ØAK	ØBD	BB	BF	BR(R)	C	CE	XU	XU Tol.	XV	Keyway	Wt. lb (kg)			
Z609DA	56C	607	5.87 (149.1)	4.50 (114.3)	6.69 (170.0)	-	0.43 (11.0)	4	10.61 (269.5)	11.63 (295.5)	0.63 (15.9)	0.0007 / 0 (0.018/0)	1.1 (28.0)	3/16 x 3/32 (4.762 x 2.381)	70			
A610DA		607							11.76 (298.8)	12.78 (324.7)					95			
B612DA		607							13.25 (336.6)	14.27 (362.5)					163			
B612DB		609							14.06 (357.2)	15.09 (383.3)					1.18 (30.0)	170		
	14.47 (367.6)		0.88 (22.3)	0.0008 / 0 (0.021 / 0)	1.57 (39.9)													
C614DA	56C	607	3.75 (95.3)	3.00 (76.2)	4.33 (110.0)	-	0.43 (11.0)	4	15.79 (401.1)	16.81 (427.0)	0.63 (15.9)	0.0007 / 0 (0.018/0)	1.1 (28.0)	3/16 x 3/32 (4.762 x 2.381)	253			
C614DB		609	16.5 (419.1)	17.53 (445.3)	1.18 (30.0)				262									
	C614DC		610	5.87 (149.1)	4.50 (114.3)	6.69 (170.0)	-	0.43 (11.0)	4	16.91 (429.6)	17.88 (454.2)	0.88 (22.3)	0.0008 / 0 (0.021 / 0)	1.57 (39.9)	3/16 x 3/32 (4.762 x 2.381)	265		
16.82 (427.3)		17.88 (454.2)		0.63 (15.9)	0.0007 / 0 (0.018/0)	1.18 (30.0)				265								
17.29 (439.2)		0.88 (22.3)		0.0008 / 0 (0.021 / 0)	1.65 (42.0)	265												
D616DA	56C	609	5.87 (149.1)	4.50 (114.3)	6.69 (170.0)	-	0.43 (11.0)	4	18.23 (463.1)	19.04 (483.7)	1.13 (28.6)	0.0016 / 0.0008 (0.041 / 0.020)	1.89 (48.1)	1/4 x 1/8 (6.35 x 3.175)	272			
									18.64 (473.5)	19.67 (499.7)					0.63 (15.9)	0.0007 / 0 (0.018/0)	1.18 (30.0)	466
D616DB	56C	610	5.87 (149.1)	4.50 (114.3)	6.69 (170.0)	-	0.43 (11.0)	4	19.05 (483.9)	20.02 (508.6)	0.88 (22.3)	0.0008 / 0 (0.021 / 0)	1.57 (39.9)	3/16 x 3/32 (4.762 x 2.381)	471			
									18.96 (481.6)	20.02 (508.6)					0.63 (15.9)	0.0007 / 0 (0.018/0)	1.18 (30.0)	479
									19.43 (493.6)	21.18 (538.0)					1.13 (28.6)	0.002 / 0.001 (0.050 / 0.025)	2.64 (67.1)	479
D616DC	56C	612	5.87 (149.1)	4.50 (114.3)	6.69 (170.0)	-	0.43 (11.0)	4	20.37 (517.4)	21.18 (538.0)	1.13 (28.6)	0.0016 / 0.0008 (0.041 / 0.020)	2.48 (63.0)	1/4 x 1/8 (6.35 x 3.175)	489			
									19.85 (504.2)	20.91 (531.2)					0.63 (15.9)	0.0007 / 0 (0.018/0)	1.18 (30.0)	492
									20.04 (509.1)	21.83 (554.5)					0.88 (22.3)	0.002 / 0.001 (0.050 / 0.025)	2.64 (67.1)	492
									21.14 (537.0)	21.83 (554.5)					1.13 (28.6)	0.0016 / 0.0008 (0.041 / 0.020)	2.48 (63.0)	492
E617DA	56C	609	5.87 (149.1)	4.50 (114.3)	6.69 (170.0)	-	0.43 (11.0)	4	21.26 (540.1)	21.83 (554.5)	1.38 (35.0)	0.002 / 0.001 (0.050 / 0.025)	2.64 (67.1)	5/16 x 5/32	623			
									20.02 (508.6)	21.05 (534.7)					0.63 (15.9)	0.0007 / 0 (0.018/0)	1.18 (30.0)	628
E617DB	56C	610	5.87 (149.1)	4.50 (114.3)	6.69 (170.0)	-	0.43 (11.0)	4	20.43 (519.0)	21.40 (543.6)	0.88 (22.3)	0.0008 / 0 (0.021 / 0)	1.57 (39.9)	3/16 x 3/32 (4.762 x 2.381)	628			
									20.34 (516.7)	21.40 (543.6)					0.63 (15.9)	0.0007 / 0 (0.018/0)	1.18 (30.0)	636
									20.81 (528.6)	22.56 (573.1)					1.13 (28.6)	0.0008 / 0 (0.021 / 0)	1.89 (48.1)	636
E617DC	56C	612	5.87 (149.1)	4.50 (114.3)	6.69 (170.0)	-	0.43 (11.0)	4	21.75 (552.5)	22.56 (573.1)	1.38 (35.0)	0.002 / 0.001 (0.050 / 0.025)	2.64 (67.1)	5/16 x 5/32	641			
									21.31 (541.3)	22.37 (568.2)					0.63 (15.9)	0.0007 / 0 (0.018/0)	1.18 (30.0)	644
									21.5 (546.1)	22.6 (574.1)					0.88 (22.3)	0.0016 / 0.0008 (0.041 / 0.020)	1.5 (38.1)	644
									22.6 (574.1)	23.29 (591.6)					1.13 (28.6)	0.002 / 0.001 (0.050 / 0.025)	2.64 (67.1)	644

3

How to Select

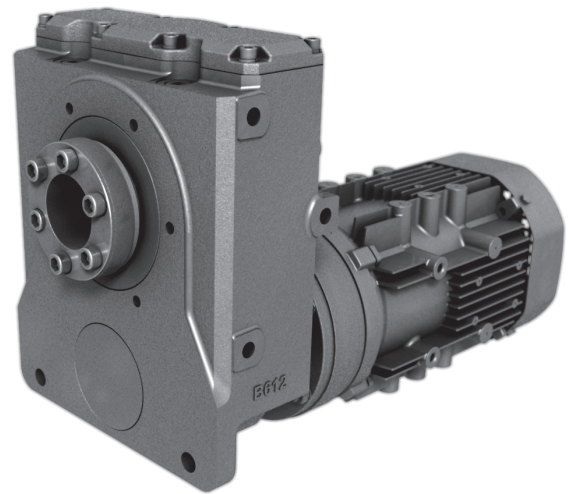

Cyclo® HBB

How to
Select

How to Select a Gearmotor

Step 1: Collect data about your application

Before starting you need to know the:

- Application (e.g. Conveyor, Mixer, etc.)
- Hours of Operation per day
- Motor Horsepower (HP) and Speed (RPM)
- Desired Output Speed
- Mounting Position and Style
- Overhung or Thrust Loads
- Bore Dimensions, inch or metric
- Electrical Specifications

Step 2: Choose a Mounting Position

Find the correct Mounting Position from the Mounting Positions Table on the right.

Step 3: Select a Frame Size

3A: Find the Load Classification of your application in the AGMA Load Classification Tables on pages 3.6 and 3.7.

3B: Go to the Gearmotor Selection Table that corresponds to the desired Mounting Position and Motor HP. Find the Output Speed closest to the desired output speed.

3C: Locate the Service Class in the Gearmotor Selection Table for your application and select the Frame Size SELECTION that matches the HP, Output Speed, and Service Class.

Step 4: Verify Dimensions

Use the Dimensions information on pages 3.80–3.91 to verify that the selected Frame Size is appropriate.

Step 5: Choose a Bushing Bore Size

Choose a Taper-Grip® Bushing Bore Size from the Stock Bushing Bore Size Table.

Step 6: Choose Options

Please refer to Options section 4.1.

For additional available options refer to our online Product Configurator at www.sumitomodrive.com/configurator

Step 7: Configure a Model Number

Go to page 3.4 to configure a model number.

Note: You will use the information you gather from the procedure on this page to Configure a Model Number.

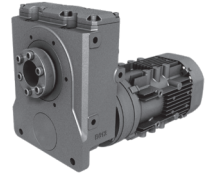

Mounting Positions (Please see the Appendix, Section 5, for additional mounting positions.)

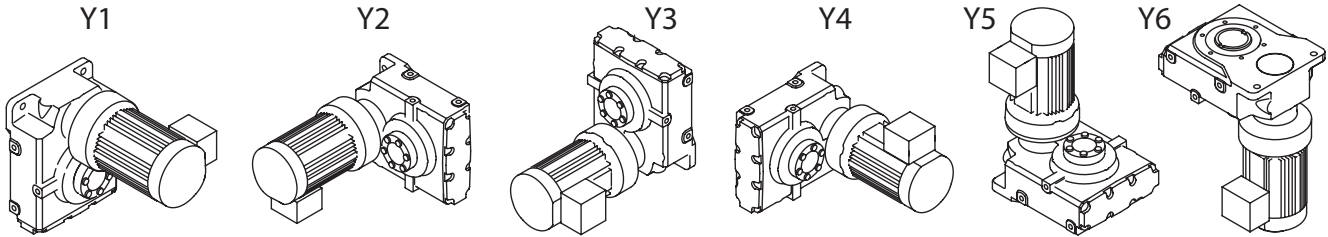

Select a Frame Size

• Mounting Position

Double Reduction
Selection Tables: Y1, Y2, Y3, Y4, Y5, Y6

5 HP
(3.7 kW)

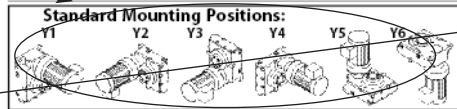

Dimension Pages:
Single Reduction 3.80-3.85
Double Reduction 3.86-3.89

Frequency	50 Hz	60 Hz
Input Speed	1450 RPM	1750 RPM
Number of Poles	4	

• Motor HP

• Output Speed

• Service Class

• SELECTION

50Hz				60 Hz				Selection			VFD ⁽¹⁾
Output Speed (RPM)	Output Torque in-lbs (N·m)	Service Factor SF	AGMA Class	Output Speed (RPM)	Output Torque in-lbs (N·m)	Service Factor SF	AGMA Class	Motor Power Code	Base Frame Size	Ratio	
3.98	72400 (8180)	0.79	-	4.81	60000 (6780)	0.95	-	5	D616DC	364	
		1.10	I			1.33	I	5	E617DC	364	
3.42	84200 (9520)	0.68	-	4.13	69800 (7880)	0.82	-	5	D616DC	424	
		0.95	-			1.15	I	5	E617DC	424	
2.90	99500 (11200)	0.58	-	3.50	82500 (9320)	0.69	-	5	D616DC	501	
		0.80	-			0.97	-	5	E617DC	501	
2.51	115000 (13000)	0.50	-	3.03	95200 (10800)	0.60	-	5	D616DC	578	
		0.70	-			0.84	-	5	E617DC	578	
2.12	136000 (15300)	0.42	-	2.56	112000 (12700)	0.51	-	5	D616DC	683	
		0.59	-			0.71	-	5	E617DC	683	
1.79	161000 (18200)	0.50	-	2.16	133000 (15100)	0.60	-	5	E617DC	809	
1.52	190000 (21500)	0.42	-	1.83	157000 (17800)	0.51	-	5	E617DC	956	

Cyclo® HBB

How to Select

STOCK BUSHING BORES

Size	Inch Sizes	Metric Sizes	Min. Bore
Z	1 ³ / ₁₆ , 1 ⁷ / ₁₆ ,	30, 40	1 ³ / ₁₆
A	1 ¹⁵ / ₁₆ , 2 ³ / ₁₆	50, 55	1 ¹¹ / ₁₆
B	2 ³ / ₁₆ , 2 ⁷ / ₁₆	60, 65	1 ¹⁵ / ₁₆
C	2 ⁷ / ₁₆ , 2 ¹⁵ / ₁₆	65, 75	2 ³ / ₁₆
D	2 ¹⁵ / ₁₆ , 3 ⁷ / ₁₆	75, 85	2 ⁷ / ₁₆
E	3 ⁷ / ₁₆ , 3 ¹⁵ / ₁₆	90, 100	2 ¹⁵ / ₁₆

For special circumstances affecting Frame Size selection such as:

- Overhung Load
- Shock Loading

Consult Appendix, pages 5.7

If Overhung Load is present, it must be checked against the capacity of the selection.



Configure a Model Number

Output Shaft Orientation

Type	Code
Horizontal	H
Vertical	V

Mounting Style

Type	Code
Flange (Keyed Hollow Bore) pg. 4.2	F
Shaft Mount (Hollow Shaft)	Y

Input Connection

Input Connection	Code
Gearmotor	M

Modification

	Code
Special	S
Standard	

Gearmotor HP (applies only to 1750 RPM)

HP	kW	Code
1/8	(0.1)	01
1/4	(0.2)	02
1/3	(0.25)	03
1/2	(0.4)	05
3/4	(0.55)	08
1	(0.75)	1
1 1/2	(1.1)	1H
2	(1.5)	2
3	(2.2)	3
EP 5	(3.7)	5
7 1/2	(5.5)	8
10	(7.5)	10
15	(11)	15
20	(15)	20
25	(18.5)	25
30	(22)	30
40	(30)	40

Frame Size

Single Reduction Input

Z6090	B6120	D6160
Z6095	B6125	D6165
A6100	C6140	E6170
A6105	C6145	E6175

Double Reduction Input

Z609DA	C614DB	D616DC
A610DA	C614DC	E617DA
B612DA	D616DA	E617DB
B612DB	D616DB	E617DC
C614DA		

AGMA Class

Class	Code
I	A
II	B
III	C

Motor and Bearing Specification

Specification	Code
AF Motor (Inverter Duty 1/8 HP to 3/4 HP)	AV
Inverter Ready Motor Premium Efficiency (1+HP), IE3	EP
High Capacity Bearing (Required for Screw Conveyor)	R1

Note: When there are multiple suffices, sequence them alphabetically. Ex.: EPR1

Brake

	Code
With Brake	B
No Brake	-

Include the following information when ordering:

- Motor Specifications (230/460 VAC 60 Hz is supplied, unless otherwise specified)
- Taper Grip Bushing or Keyed Hollow Bore diameter (refer to pages 4.2 to 4.3 for diameters)
- Optional conduit box positions must be specified, or standard is provided, refer to page 5.14
- Optional Industry Package, refer to page 4.6
- Specify type for nonstandard torque arm or no torque arm

Cyclo® HBB

Nomenclature

E V Y M **5** - **B 6 1 2 5** **Y** **B** - **EP** **Y5** - **B** - **53**

Gearmotor HP
(1750 rpm)

Frame size

AGMA
class

Brake

Ratio

Modification (Special feature)

Input connection

Mounting style

Output shaft orientation

Cyclo® HBB product code (always "E")

Motor Specification

(as required)

Shaft specification

Nomenclature

Shaft Specifications

Input Shaft	Hollow Output Shaft	Suffix
mm	Key (mm)	
Inch	Key (Inch)	K
mm	Taper-Grip®	M
Inch	Taper-Grip®	Y

Mounting Positions (Please see the Appendix, Section 5, for additional mounting positions.)

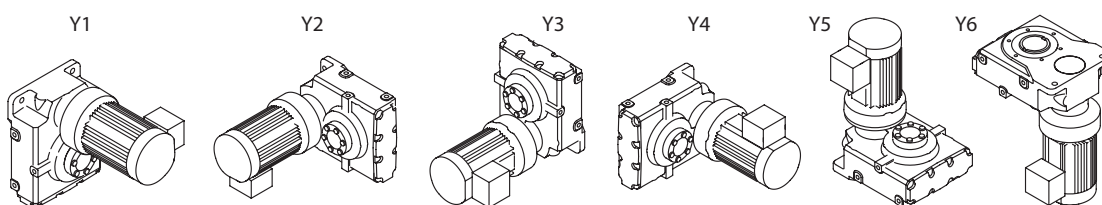

Nominal Total Ratio

Single Reduction Input		Double Reduction Input	
Input Ratio	Total Ratio	Input Ratio	Total Ratio
3	11	104	364
5	18	121	424
6	21	143	501
8	28	165	578
11	39	195	683
13	46	231	809
15	53	273	956
17	60	319	1117
21	74	377	1320
25	88	473	1656
29	102	559	1957
35	123	649	2272
43	151	731	2559
51	179	841	2944
59	207	1003	3511
71	249	1247	4365
87	305	1479	5177
119	417	1849	6472
		2065	7228
		2537	8880
		3045	10568
		3481	12184
		4437	15530
		5133	17966
		6177	21620
		7569	26492

Nomenclature Example:

EVYM5 – B6125YB – EP Y5 – 53

E – Cyclo Helical Buddybox	B6125 – Frame Size
V – Vertical	Y – Inch Shaft Specification
Y – Shaft Mount (Hollow Shaft)	B – AGMA Class II
M – Integral Motor	EP – Three-Phase Motor Premium Efficiency
5 – 5 HP, 1750 RPM	Y5 – Mounting Position
	53 – Ratio

Cyclo® HBB

Nomenclature

AGMA Load Classifications: Gearmotors

Select Service factor by Method A or B or C:

Method A - Gearmotor Classification by LOAD

DURATION OF SERVICE	GEARMOTOR CLASS		
	UNIFORM LOAD	MODERATE SHOCK LOAD	HEAVY SHOCK LOAD
Intermittent 3 hours per day	Class I	Class I	Class II
Up to 10 hours per day	Class I	Class II	Class III
24 hours per day	Class II	Class III	—

Class I = Steady loads not exceeding normal motor rating, 8 to 10 hours a day. Moderate shock loads where service is intermittent (AGMA Service Factor: 1.0).

Class II = Steady loads not exceeding normal motor rating and 24 hours a day service. Moderate shock loads for 8 hours a day (AGMA Service Factor: 1.4).

Class III = Moderate shock loads for 24 hours a day or heavy shock loads for 8 hours a day (AGMA Service Factor: 2.0)

Note: Selections without an AGMA Class designation are torque based selections generally used for intermittent service.

Method B - Recommended Service Factors for Frequent Start-Stop Applications for EP Motors

For frequent start-stop applications with motor operated across the line, use the table below to determine the recommended service factor, and check the Motor Thermal Rating (Table 5.30) in Section 5. For determination of moment of inertia, see page 5.9.

Number of start-stops (Times/hour)	~ 10 hours/day			~24 hours/day			
	I	II	III	I	II	III	
~10	1	1.1	1.35	1.2	1.25	1.5	Three-phase motors from 1/8 HP to 3/4 (0.1 to 0.55 kW)
~200	1.1	1.3	1.5	1.25	1.5	1.65	
~500	1.15	1.45	1.6	1.3	1.6	1.75	
1	1	1.1	1.35	1.2	1.25	1.5	Premium Efficiency three-phase motors 1HP to 75 HP (0.75 to 55 kW), high-efficiency three-phase motors from 1/4 HP to 1/2 HP (0.2 to 0.4 kW)
~3	1	1.2	1.45	1.2	1.35	1.55	
~10	1	1.3	1.5	1.2	1.45	1.65	
~60	1	1.4	1.6	1.2	1.65	1.8	

$$\text{Inertia (Moment of Inertia } WR^2 \text{) Ratio} = \frac{\text{Total Moment of Inertia (} WR^2 \text{) as seen from motor shaft}}{\text{Moment of Inertia (} WR^2 \text{) of motor}}$$

- I = Allowable Inertia (WR^2) Ratio: Inertia Ratio ≤ 0.3
- II = Allowable Inertia (WR^2) Ratio: $0.3 < \text{Inertia Ratio} \leq 3.0$
- III = Allowable Inertia (WR^2) Ratio: $3.0 < \text{Inertia Ratio} \leq 10.0$

- Note:**
1. The number of start-stops includes brake or clutch operation times.
 2. Consult us when starting under loaded conditions such as torque or radial load.
 3. Consult us when start-stop frequency or Moment of Inertia Ratio exceeds that shown above.

- Specification Inspection Items
- if there is a shoulder bolt or knockpin used on mating surface of reducer
 - change in case material
 - if using high frequency brake

Method C - Load Classification by INDUSTRY

Application	Class		Application	Class		Application	Class		Application	Class	
	Up to 10 Hr. Per Day	24 Hr. Per Day		Up to 10 Hr. Per Day	24 Hr. Per Day		Up to 10 Hr. Per Day	24 Hr. Per Day		Up to 10 Hr. Per Day	24 Hr. Per Day
Brewing & Distilling			Lumber Industry			Paper Mills			Sewage Disposal		
Bottling Machinery	I	II	Barkers–Spindle Feed	Consult Factory	III	Agitators (Mixers)	II	II	Aerators	II	II
Brew Kettles, Cont. Duty	–	II	Barkers–Main Drive	Consult Factory	III	Barker–Auxiliaries–Hyd.	Consult Factory	II	Bar Screens	I	II
Can Filling Machines	I	II	Carriage Drive	Consult Factory	III	Barker, Mechanical	Consult Factory	II	Chemical Feeders	I	II
Cookers–Cont. Duty	–	II	Conveyors	II	III	Beater & Pulper	–	II	Collectors	I	II
Mash Tubs–Cont. Duty	–	II	Burner	II	III	Bleacher	–	II	Dewatering Screens	II	II
Scale Hoppers–Frequent Starts	II	II	Main or Heavy Duty Main Log	III	III	Calenders	–	II	Grit Collectors	I	II
Clay Working Industry			Re-Saw Merry-Go-Round	II	III	Calenders–Super	–	II	Scum Breakers	II	II
Brick Press	III	III	Slab	II	III	Converting Mach.–Except Cutters–Platers	–	II	Slow or Rapid Mixers	II	II
Briquette Machines	III	III	Transfer	II	III	Conveyors	–	II	Sludge Collectors	I	II
Clay Working Machinery	II	II	Chains–Floor	II	III	Couch	–	II	Thickeners	II	II
Pug Mills	II	II	Chains–Green	II	III	Cutters, Platers	–	III	Vacuum Filters	II	II
Distilling (See Brewing)			Cut-Off Saws–Chain	II	III	Cylinders	–	II	Textile Industry		
Dredges			Cut-Off Saws–Drag	II	III	Dryers	–	II	Batchers	II	II
Cable Reels	II	–	Debarking Drums	Consult Factory	III	Felt Stretchers	–	II	Calenders	II	II
Conveyors	II	II	Feeds–Edger	II	III	Felt Whippers	–	III	Card Machines	II	II
Cutter Head Drives	III	III	Feeds–Gang	III	III	Jordans	–	II	Cloth Finishing Machines (Calenders, Dryers, Pads, Tenter, Washers)	II	II
Jig Drives	III	III	Feeds–Trimmer	II	III	Log Haul	–	II	Dry Cans	II	II
Maneuvering Winches	II	–	Log Deck	III	III	Presses	–	II	Dyeing Machinery	II	II
Pumps	II	II	Log Hauls–Incline, Well Type	III	III	Pulp Machine Reels	–	II	Knitting Machinery	Consult Factory	II
Screen Drives	III	III	Log Turning Devices	III	III	Stock Chests	–	II	Looms, Mangles, Nappers	II	II
Stackers	II	II	Planer Feed	II	III	Suction Rolls	–	II	Range Drives	Consult Factory	II
Utility Winches	II	–	Planer Tilting Hoists	II	III	Washers & Thickeners	–	II	Soapers, Spinners	II	II
Food Industry			Rolls–Live–Off	II	III	Winders	–	II	Tenter Frames	II	II
Beet Slicers	II	II	Bearing–Roll Cases	III	III	Rubber Industry			Winders	II	II
Bottlings, Can Filling Mach.	I	II	Sorting Table	II	III	Mixer	III	III	Yarn Preparatory Machinery (Cards, Spinners, Slashers)	II	II
Cereal Cookers	I	II	Tipple Hoist	II	III	Rubber Calender	II	II			
Dough Mixers	II	II	Transfers–Chain	II	III	Rubber Mill (2 or more)	II	II			
Meat Grinders	II	II	Transfers–Craneway	II	III						
			Tray Drives	II	III						
			Oil Industry								
			Chillers	II	II						

...table continued on next page.

Load Classification by APPLICATION

Application	Class		Application	Class		Application	Class		Application	Class	
	Up to 10 Hr. Per Day	24 Hr. Per Day		Up to 10 Hr. Per Day	24 Hr. Per Day		Up to 10 Hr. Per Day	24 Hr. Per Day		Up to 10 Hr. Per Day	24 Hr. Per Day
Agitators Pure Liquids Liquids and Solids Liquids – Variable Density Semi-liquids – Variable Density	I	II	Jig Drives Maneuvering Winches Pumps Screen Drive Stackers Utility Winches	III	III	Tray Drives Veneer Lathe Drives	II	III	Pullers Barge Haul	III	III
Blowers Centrifugal Lobe Vane	I	II	Elevators Bucket – Uniform Load Bucket – Heavy Load Bucket – Continuous Centrifugal Discharge Escalators Freight Gravity Discharge Man Lifts Passenger Service – Hand Lift	I	II	Machine Tools Bending Roll Notching Press – Belt Driven Plate Planer Punch Press – Gear Driven Tapping Machines Other Machine Tools Main Drives Auxiliary Drives	II	II	Pumps Centrifugal Proportioning Reciprocating Single Acting 3 or more Cylinders Double Acting 2 or more Cylinders Single Acting 1 or 2 Cylinders Double Acting Single Cylinder Rotary – Gear Type – Lobe, Vane	I	II
Brewing and Distilling Bottling Machinery Brew Kettles – Continuous Duty Cookers – Continuous Duty Mash Tubs – Continuous Duty Scale Hopper Frequent Starts	I	II	Fans Centrifugal Cooling Towers Induced Draft Forced Draft Induced Draft Large (Mine, etc.) Large Industrial Light (Small Diameter)	I	II	Metal Mills Bridle Roll Drives Draw Bench – Carriage Draw Bench – Main Drive Forming Machines Pinch Dryer & Scrubber Rolls, Reversing Slitters Table Conveyors Non-Reversing Reversing Winding Reels – Strip Wire Drawing & Flattening Machine Wire Winding Machine	III	III	Rubber Industry Mixer Rubber Calender Rubber Mill (2 or more) Sheeter Tire Building Machines Tire & Tube Press Openers Tubers & Strainers	III	III
Can Filling Machines	I	II	Feeders Apron Belt Disc Reciprocating Screw	II	II	Mills, Rotary Type Ball Cement Kilns Dryers & Coolers Kilns Pebble Rod Tumbling Barrels	III	III	Sewage Disposal Equipment Aerators Bar Screens Chemical Feeders Collectors, Circuline or Straightline Dewatering Screens Grit Collectors Scum Breakers Slow or Rapid Mixers Sludge Collectors Thickeners Vacuum Filters	Consult Factory	I
Cane Knives	II	II	Food Industry Beet Slicer Cereal Cooker Dough Mixer Meat Grinders	II	II	Mixers Concrete Mixers, Continuous Concrete Mixers, Intermittent Constant Density Variable Density	II	II	Screens Air Washing Rotary – Stone or Gravel Traveling Water Intake	I	II
Car Dumpers	III	–	Generators – (Not Welding)	I	II	Oil Industry Chillers Oil Well Pumping Paraffin Filter Press Rotary Kilns	II	II	Slab Pushers Steering Gear Stokers	II	II
Car Pullers – Intermittent Duty	I	–	Hammer Mills	III	III	Paper Mills Aerators Agitators (Mixers) Barker Auxiliaries, Hydraulic Barker, Mechanical Barking Drum Beater & Pulper Bleacher Calenders Calenders – Super Converting Machines, except Cutters, Platers Conveyors Conveyors, Log Couch Cutters, Platers Cylinders Dryers Felt Stretcher Felt Whipper Jordans Presses Pulp Machines, Reel Stock Chests Suction Roll Washers and Thickeners Winders	II	II	Textile Industry Batchers Calenders Card Machines Cloth Finishing Machines (Washers, Pads, Tenters) (Dryers, Calenders, etc.) Dry Cans Dryers Dyeing Machinery Knitting Machines (Looms, etc.) Looms Mangles Nappers Pads Range Drives Slashers Soapers Spinnners Tenter Frames Washers Winders (Other than Batchers) Yarn Preparatory Machines (Cards, Spinners, Slashers, etc.)	II	II
Clarifiers	I	II	Laundry Washers Reversing	II	II	Printing Presses	I	II	Windlass	II	II
Classifiers	II	II	Laundry Tumblers	II	II						
Clay Working Machinery Brick Press Briquette Machine Clay Working Machinery Pug Mill	III	III	Line Shafts Heavy Shock Load Moderate Shock Load Uniform Load	III	III						
Compressors Centrifugal Lobe Reciprocating Multi-Cylinder Single Cylinder	I	II	Lumber Industry Barkers – Spindle Feed Barkers – Main Drive Carriage Drive Conveyors – Burner Conveyors – Main or Heavy Duty Conveyors – Main Log Conveyors – Merry-Go-Round Conveyors – Slab Conveyors – Transfer Conveyors – Waste Chains – Floor Chains – Green Cut-Off Saws – Chain Cut-Off Saws – Drag Debarking Drums Feeds – Edger Feeds – Gang Feeds – Trimmer Log Deck Log Hauls – Incline Well Type Log Turning Devices Planer Feed Planer Tilting Hoists Rolls – Live – Off Brg. – Roll Cases Sorting Table Tipple Hoist Transfers – Chain Transfers – Craneway	II	II						
Conveyors – Uniformly Loaded or Fed Apron Assembly Belt Bucket Chain Flight Oven Screw	I	II									
Conveyors – Heavy Duty Not Uniformly Fed Apron Assembly Belt Bucket Chain Flight Live Roll (Package) Oven Reciprocating Screw Shaker	II	II									
Cranes and Hoists Main Hoists Heavy Duty Medium Duty Reversing Skip Hoists Trolley Drive Bridge Drive	III	III									
Crushers Ore Stone	III	III									
Dredges Cable Reels Conveyors Cutter Head Drives	II	–									

Cyclo® HBB

AGMA Tables

Constant Torque Speed Ranges: Gearmotors

Table 3.8 Turn Down Ratio (CTSR) for Integral Motors in CONSTANT TORQUE Applications Powered by Inverter VFDs.

Fractional HP Motors - 60 Hz			
Motor Power (4 - Pole)	Standard Motor		AF Motor
	W/o Brake	With Brake	With or Without Brake
1/8 HP (0.1 kW)	2:1	2:1	10:1
1/4 HP (0.2 kW)	2:1	2:1	10:1
1/3 HP (0.25 kW)	2:1	2:1	10:1
1/2 HP (0.4 kW)	2:1	2:1	10:1
3/4 HP (0.55 kW)	2:1	2:1	10:1

Premium Efficiency Integral HP Motors - 60 Hz			
Motor Power (4 - Pole)	Standard Motor		Oversized Motor
	W/o Brake	With Brake	With SSC YA01 Brake
1 HP (0.75 kW)	10:1	10:1	
1.5 HP (1.1 kW)	10:1	5:1	10:1
2 HP (1.5 kW)	10:1	4:1	10:1
3 HP (2.2 kW)	10:1	4:1	10:1
5 HP (3.7 kW)	10:1	4:1	10:1
7.5 HP (5.5 kW)	10:1	4:1	10:1
10 HP (7.5 kW)	10:1	6:1	10:1
15 HP (11 kW)	10:1	6:1	10:1
20 HP (15 kW)	10:1	10:1	
25 HP (18.5 kW)	10:1	10:1	
30 HP (22 kW)	10:1	10:1	
40 HP (30 kW)	10:1	10:1	

For motor selection considerations for inverter (VFD) operation please refer to pages 5.26 and 5.27.

Cyclo® 6000 HBB
Selection Tables

This page intentionally left blank.

Cyclo® 6000
HBB

Selection
Tables

Single Reduction Selection Tables: Y1, Y2, Y3, Y4

**1/8 HP
(0.1 kW)**

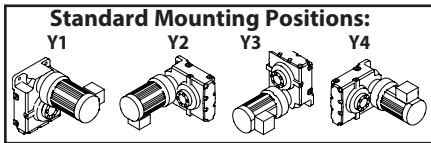

Selection Table Pages:

Single Reduction	
-Y1,Y2,Y3,Y4	3.10-3.38
-Y5,Y6	3.39-3.61
Double Reduction	
-Y1,Y2,Y3,Y4,Y5,Y6	3.62-3.79

Dimension Pages:

Single Reduction	3.80-3.85
Double Reduction	3.86-3.91

Frequency	50 Hz	60 Hz
Input Speed	1450 RPM	1750 RPM
Number of Poles	4	

Output Speed (RPM)	50Hz				60 Hz				Selection			VFD ^[1]	
	Output Torque		Service Factor		Output Speed (RPM)	Output Torque		Service Factor		Base			
	in-lbs	(N·m)	SF	AGMA Class		in-lbs	(N·m)	SF	AGMA Class	Motor Power Code	Frame Size		Ratio
7.02	1110	(125)	3.09	III	8.47	920	(104)	3.09	III	01	Z6090	207	(a)
5.84	1340	(151)	2.52	III	7.04	1110	(125)	2.52	III	01	Z6090	249	(a)
			2.78	III				01	Z6095	249	(a)		
4.76	1640	(185)	2.11	III	5.75	1360	(153)	2.11	III	01	Z6090	305	(a)
			2.39	III				01	Z6095	305	(a)		
3.48	2240	(253)	1.25	I	4.20	1850	(210)	1.25	I	01	Z6090	417	(a)
			1.45	II				01	Z6095	417	(a)		

Cydo® HBB

Selection
Tables

Notes: [1] Variable Frequency Drive (VFD) notes (see page 3.8 for Constant Torque Speed Ranges):

(-) = For Inverter Operation, starting condition may require ambient temperature of 5° C or higher.

(a) = Both AV and non-AV motors can be used for selection.

Single Reduction Selection Tables: Y1, Y2, Y3, Y4

**1/4 HP
(0.2 kW)**

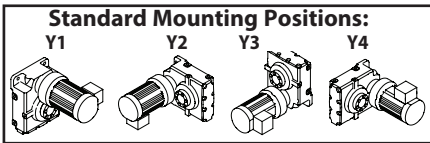

Selection Table Pages:

Single Reduction	3.10-3.38
-Y1,Y2,Y3,Y4	3.10-3.38
-Y5,Y6	3.39-3.61
Double Reduction	3.62-3.79
-Y1,Y2,Y3,Y4,Y5,Y6	3.62-3.79

Dimension Pages:

Single Reduction	3.80-3.85
Double Reduction	3.86-3.91

Frequency	50 Hz	60 Hz
Input Speed	1450 RPM	1750 RPM
Number of Poles	4	

50Hz					60 Hz					Selection			
Output Speed (RPM)	Output Torque		Service Factor		Output Speed (RPM)	Output Torque		Service Factor		Motor Power Code	Base		VFD ^[1]
	in-lbs	(N·m)	SF	AGMA Class		in-lbs	(N·m)	SF	AGMA Class		Frame Size	Ratio	
14.3	1090	(123)	3.13	III	17.2	904	(102)	3.13	III	02	Z6090	102	(a)
11.8	1320	(149)	2.97	III	14.3	1090	(123)	3.06	III	02	Z6090	123	(a)
			2.97	III				3.58	III	02	Z6095	123	(a)
9.63	1620	(183)	2.18	III	11.6	1340	(151)	2.18	III	02	Z6090	151	(a)
			2.41	III				2.91	III	02	Z6095	151	(a)
8.12	1920	(217)	1.66	II	9.80	1590	(180)	1.66	II	02	Z6090	179	(a)
			2.04	III				2.11	III	02	Z6095	179	(a)
			2.80	III				2.80	III	02	A6100	179	(a)
7.02	2220	(251)	1.54	II	8.47	1840	(208)	1.54	II	02	Z6090	207	(a)
			1.68	II				1.86	II	02	Z6095	207	(a)
			2.58	III				2.58	III	02	A6100	207	(a)
5.84	2670	(302)	1.26	I	7.04	2210	(250)	1.26	I	02	Z6090	249	(a)
			1.39	I				1.51	II	02	Z6095	249	(a)
			2.18	III				2.18	III	02	A6100	249	(a)
			2.53	III				2.81	III	02	A6105	249	(a)
4.76	3270	(370)	1.06	I	5.75	2710	(306)	1.06	I	02	Z6090	305	(a)
			1.19	I				1.44	II	02	Z6095	305	(a)
			2.17	III				2.17	III	02	A6100	305	(a)
			2.39	III				2.83	III	02	A6105	305	(a)
3.48	4480	(506)	1.05	I	4.20	3710	(419)	1.05	I	02	A6100	417	(a)
			1.43	II				1.43	II	02	A6105	417	(a)

Cyclo® HBB

Selection
Tables

Notes: [1] Variable Frequency Drive (VFD) notes (see page 3.8 for Constant Torque Speed Ranges):

(-) = For Inverter Operation, starting condition may require ambient temperature of 5° C or higher.

(a) = Both AV and non-AV motors can be used for selection.

Single Reduction Selection Tables: Y1, Y2, Y3, Y4

**1/3 HP
(0.25 kW)**

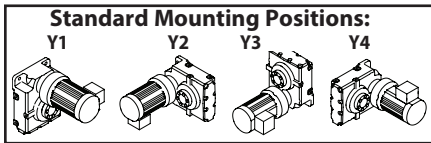

Selection Table Pages:

Single Reduction	
-Y1,Y2,Y3,Y4	3.10-3.38
-Y5,Y6	3.39-3.61
Double Reduction	
-Y1,Y2,Y3,Y4,Y5,Y6	3.62-3.79

Dimension Pages:

Single Reduction	3.80-3.85
Double Reduction	3.86-3.91

Frequency	50 Hz	60 Hz
Input Speed	1450 RPM	1750 RPM
Number of Poles	4	

50Hz					60 Hz					Selection			
Output Speed (RPM)	Output Torque		Service Factor		Output Speed (RPM)	Output Torque		Service Factor		Motor Power Code	Base		VFD ^[1]
	in-lbs	(N·m)	SF	AGMA Class		in-lbs	(N·m)	SF	AGMA Class		Frame Size	Ratio	
19.7	988	(112)	3.03	III	23.8	818	(92.5)	3.03	III	03	Z6090	74	(a)
16.6	1180	(133)	2.68	III	20.0	974	(110)	2.68	III	03	Z6090	88	(a)
14.3	1360	(154)	2.50	III	17.2	1130	(128)	2.50	III	03	Z6090	102	(a)
			2.86	III				3.13	III		Z6095	102	(a)
11.8	1650	(186)	2.37	III	14.3	1360	(154)	2.45	III	03	Z6090	123	(a)
			2.37	III				2.86	III		Z6095	123	(a)
9.63	2020	(228)	1.74	II	11.6	1680	(189)	1.74	II	03	Z6090	151	(a)
			1.93	II				2.33	III		Z6095	151	(a)
			3.12	III				3.12	III		A6100	151	(a)
8.12	2400	(271)	1.33	I	9.80	1990	(225)	1.33	I	03	Z6090	179	(a)
			1.63	II				1.69	II		Z6095	179	(a)
			2.24	III				2.24	III		A6100	179	(a)
			3.10	III				3.10	III		A6105	179	(a)
7.02	2770	(313)	1.24	I	8.47	2300	(260)	1.24	I	03	Z6090	207	(a)
			1.34	I				1.49	II		Z6095	207	(a)
			2.06	III				2.06	III		A6100	207	(a)
			2.72	III				2.83	III		A6105	207	(a)
5.84	3340	(377)	1.01	I	7.04	2770	(313)	1.01	I	03	Z6090	249	(a)
			1.11	I				1.21	I		Z6095	249	(a)
			1.74	II				1.74	II		A6100	249	(a)
			2.02	III				2.24	III		A6105	249	(a)
4.76	4090	(462)	0.85	-	5.75	3390	(383)	0.85	-	03	Z6090	305	(a)
			0.95	-				1.15	I		Z6095	305	(a)
			1.73	II				1.73	II		A6100	305	(a)
			1.91	II				2.26	III		A6105	305	(a)
3.48	5600	(632)	0.84	-	4.20	4640	(524)	0.84	-	03	A6100	417	(a)
			1.14	I				1.14	I		A6105	417	(a)

Cyclo® HBB

Selection
Tables

Notes: [1] Variable Frequency Drive (VFD) notes (see page 3.8 for Constant Torque Speed Ranges):

(-) = For Inverter Operation, starting condition may require ambient temperature of 5° C or higher.

(a) = Both AV and non-AV motors can be used for selection.

Single Reduction Selection Tables: Y1, Y2, Y3, Y4

**1/2 HP
(0.4 kW)**

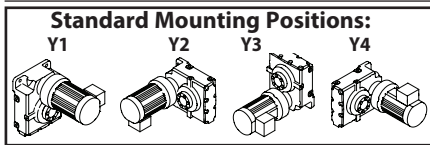

Selection Table Pages:

Single Reduction	3.10-3.38
-Y1,Y2,Y3,Y4	3.39-3.61
Double Reduction	3.62-3.79
-Y1,Y2,Y3,Y4,Y5,Y6	

Dimension Pages:

Single Reduction	3.80-3.85
Double Reduction	3.86-3.91

Frequency	50 Hz	60 Hz
Input Speed	1450 RPM	1750 RPM
Number of Poles	4	

50Hz					60 Hz					Selection				
Output Speed (RPM)	Output Torque		Service Factor		Output Speed (RPM)	Output Torque		Service Factor		Motor Power Code	Base		VFD ^[1]	
	in-lbs	(N·m)	SF	AGMA Class		in-lbs	(N·m)	SF	AGMA Class		Frame Size	Ratio		
69.0	451	(51.0)	2.87	III	83.3	374	(42.3)	2.87	III	05	Z6090	21	(a)	
51.8	602	(68.0)	2.87	III	62.5	499	(56.4)	2.87	III	05	Z6090	28	(a)	
37.7	828	(93.5)	2.87	III	45.5	686	(77.5)	2.87	III	05	Z6090	39	(a)	
31.9	978	(111)	2.87	III	38.5	810	(91.6)	2.87	III	05	Z6090	46	(a)	
27.6	1130	(128)	2.87	III	33.3	935	(106)	2.87	III	05	Z6090	53	(a)	
24.4	1280	(145)	2.87	III	29.4	1060	(120)	2.87	III	05	Z6090	60	(a)	
			3.05	III				3.68	III		05	Z6095	60	(a)
19.7	1580	(179)	1.89	II	23.8	1310	(148)	1.89	II	05	Z6090	74	(a)	
			2.47	III				2.98	III		05	Z6095	74	(a)
16.6	1880	(213)	1.68	II	20.0	1560	(176)	1.68	II	05	Z6090	88	(a)	
			2.08	III				2.17	III		05	Z6095	88	(a)
			3.17	III				3.17	III		05	A6100	88	(a)
14.3	2180	(247)	1.56	II	17.2	1810	(204)	1.56	II	05	Z6090	102	(a)	
			1.79	II				1.96	II		05	Z6095	102	(a)
			3.03	III				3.03	III		05	A6100	102	(a)
11.8	2630	(298)	1.48	II	14.3	2180	(247)	1.53	II	05	Z6090	123	(a)	
			1.48	II				1.79	II		05	Z6095	123	(a)
			2.44	III				2.44	III		05	A6100	123	(a)
			2.97	III				3.00	III		05	A6105	123	(a)
9.63	3240	(366)	1.09	I	11.6	2680	(303)	1.09	I	05	Z6090	151	(a)	
			1.21	I				1.46	II		05	Z6095	151	(a)
			1.95	II				1.95	II		05	A6100	151	(a)
			2.42	III				2.70	III		05	A6105	151	(a)
8.12	3840	(434)	0.83	-	9.80	3180	(359)	0.83	-	05	Z6090	179	(a)	
			1.02	I				1.05	I		05	Z6095	179	(a)
			1.40	II				1.40	II		05	A6100	179	(a)
			1.94	II				1.94	II		05	A6105	179	(a)
7.02	4440	(502)	0.84	-	8.47	3680	(416)	0.93	-	05	Z6095	207	(a)	
			1.29	I				1.29	I		05	A6100	207	(a)
			1.70	II				1.77	II		05	A6105	207	(a)
5.84	5340	(604)	1.09	I	7.04	4430	(500)	1.09	I	05	A6100	249	(a)	
			1.26	I				1.40	II		05	A6105	249	(a)
			2.39	III				2.39	III		05	B6120	249	(a)
			2.84	III				3.00	III		05	B6125	249	(a)
4.76	6550	(740)	1.08	I	5.75	5420	(613)	1.08	I	05	A6100	305	(a)	
			1.20	I				1.41	II		05	A6105	305	(a)
			2.36	III				2.36	III		05	B6120	305	(a)
			2.39	III				2.83	III		05	B6125	305	(a)

Notes: [1] Variable Frequency Drive (VFD) notes (see page 3.8 for Constant Torque Speed Ranges):
 (-) = For Inverter Operation, starting condition may require ambient temperature of 5° C or higher.
 (a) = Both AV and non-AV motors can be used for selection.

Cyclo® HBB

Selection
Tables

Single Reduction Selection Tables: Y1, Y2, Y3, Y4

**3/4 HP
(0.55 kW)**

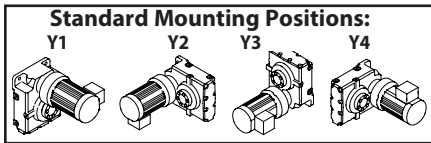

Selection Table Pages:
 Single Reduction
 -Y1,Y2,Y3,Y4 3.10-3.38
 -Y5,Y6 3.39-3.61
 Double Reduction
 -Y1,Y2,Y3,Y4,Y5,Y6 3.62-3.79

Dimension Pages:
 Single Reduction 3.80-3.85
 Double Reduction 3.86-3.91

Frequency	50 Hz	60 Hz
Input Speed	1450 RPM	1750 RPM
Number of Poles	4	

50Hz					60 Hz					Selection			
Output Speed (RPM)	Output Torque		Service Factor		Output Speed (RPM)	Output Torque		Service Factor		Motor Power Code	Base		VFD ^[1]
	in-lbs	(N·m)	SF	AGMA Class		in-lbs	(N·m)	SF	AGMA Class		Frame Size	Ratio	
69.0	621	(70.1)	2.08	III	83.3	514	(58.1)	2.08	III	08	Z6090	21	(a)
			2.75	III				2.75	III		Z6095	21	(a)
51.8	828	(93.5)	2.08	III	62.5	686	(77.5)	2.08	III	08	Z6090	28	(a)
			2.75	III				2.75	III		Z6095	28	(a)
37.7	1140	(129)	2.08	III	45.5	943	(107)	2.08	III	08	Z6090	39	(a)
			2.75	III				2.75	III		Z6095	39	(a)
31.9	1340	(152)	2.08	III	38.5	1110	(126)	2.08	III	08	Z6090	46	(a)
			2.75	III				2.75	III		Z6095	46	(a)
27.6	1550	(175)	2.08	III	33.3	1290	(145)	2.08	III	08	Z6090	53	(a)
			2.52	III				2.75	III		Z6095	53	(a)
24.4	1760	(199)	2.08	III	29.4	1460	(165)	2.08	III	08	Z6090	60	(a)
			2.22	III				2.68	III		Z6095	60	(a)
19.7	2170	(245)	1.38	I	23.8	1800	(203)	1.38	I	08	Z6090	74	(a)
			1.80	II				2.17	III		Z6095	74	(a)
16.6	2590	(292)	1.22	I	20.0	2140	(242)	1.22	I	08	Z6090	88	(a)
			1.51	II				1.58	II		Z6095	88	(a)
			2.31	III				2.31	III		A6100	88	(a)
			3.02	III				3.04	III		A6105	88	(a)
14.3	3000	(339)	1.14	I	17.2	2490	(281)	1.14	I	08	Z6090	102	(a)
			1.30	I				1.42	II		Z6095	102	(a)
			2.20	III				2.20	III		A6100	102	(a)
			2.61	III				2.89	III		A6105	102	(a)
11.8	3620	(409)	1.08	I	14.3	3000	(339)	1.11	I	08	Z6090	123	(a)
			1.08	I				1.30	I		Z6095	123	(a)
			1.77	II				1.77	II		A6100	123	(a)
			2.16	III				2.18	III		A6105	123	(a)
9.63	4450	(503)	0.88	-	11.6	3690	(416)	1.06	I	08	Z6095	151	(a)
			1.42	II				1.42	II		A6100	151	(a)
			1.76	II				1.96	II		A6105	151	(a)
8.12	5280	(596)	1.02	I	9.80	4370	(494)	1.02	I	08	A6100	179	(a)
			1.41	II				1.41	II		A6105	179	(a)
			2.96	III				3.12	III		B6120	179	(a)
			2.97	III				3.58	III		B6125	179	(a)
7.02	6100	(690)	0.94	-	8.47	5060	(571)	0.94	-	08	A6100	207	(a)
			1.24	I				1.29	I		A6105	207	(a)
			2.36	III				2.36	III		B6120	207	(a)
			2.57	III				2.95	III		B6125	207	(a)

Notes: [1] Variable Frequency Drive (VFD) notes (see page 3.8 for Constant Torque Speed Ranges):
 (-) = For Inverter Operation, starting condition may require ambient temperature of 5° C or higher.
 (a) = Both AV and non-AV motors can be used for selection.

Single Reduction Selection Tables: Y1, Y2, Y3, Y4

**3/4 HP
(0.55 kW)**

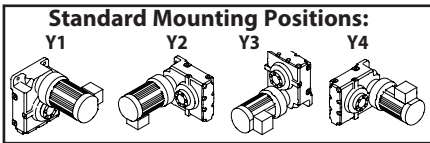

Selection Table Pages:

Single Reduction	
-Y1,Y2,Y3,Y4	3.10-3.38
-Y5,Y6	3.39-3.61
Double Reduction	
-Y1,Y2,Y3,Y4,Y5,Y6	3.62-3.79

Dimension Pages:

Single Reduction	3.80-3.85
Double Reduction	3.86-3.91

Frequency	50 Hz	60 Hz
Input Speed	1450 RPM	1750 RPM
Number of Poles	4	

50Hz				60 Hz				Selection					
Output Speed (RPM)	Output Torque		Service Factor		Output Speed (RPM)	Output Torque		Service Factor		Base		VFD ^[1]	
	in-lbs	(N·m)	SF	AGMA Class		in-lbs	(N·m)	SF	AGMA Class	Motor Power Code	Frame Size		Ratio
5.84	7350	(830)	0.92	-	7.04	6090	(688)	1.02	I	08	A6105	249	(a)
			1.74	II				08	B6120	249	(a)		
			2.07	III				08	B6125	249	(a)		
4.76	9000	(1020)	0.87	-	5.75	7460	(843)	1.03	I	08	A6105	305	(a)
			1.72	II				08	B6120	305	(a)		
			1.74	II				08	B6125	305	(a)		

Cyclo® HBB

Selection
Tables

Notes: [1] Variable Frequency Drive (VFD) notes (see page 3.8 for Constant Torque Speed Ranges):

(-) = For Inverter Operation, starting condition may require ambient temperature of 5° C or higher.

(a) = Both AV and non-AV motors can be used for selection.

Single Reduction Selection Tables: Y1, Y2, Y3, Y4

**1 HP
(0.75 kW)**

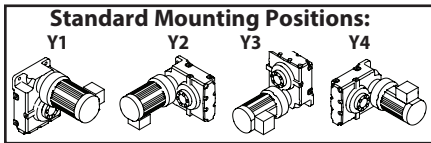

Selection Table Pages:

Single Reduction	3.10-3.38
-Y1,Y2,Y3,Y4	3.10-3.38
-Y5,Y6	3.39-3.61
Double Reduction	3.62-3.79
-Y1,Y2,Y3,Y4,Y5,Y6	3.62-3.79

Dimension Pages:

Single Reduction	3.80-3.85
Double Reduction	3.86-3.91

Frequency	50 Hz	60 Hz
Input Speed	1450 RPM	1750 RPM
Number of Poles	4	

50Hz					60 Hz					Selection			VFD ^[1]
Output Speed (RPM)	Output Torque		Service Factor		Output Speed (RPM)	Output Torque		Service Factor		Motor Power Code	Base		
	in-lbs	(N·m)	SF	AGMA Class		in-lbs	(N·m)	SF	AGMA Class		Frame Size	Ratio	
138	423	(47.8)	3.13	III	167	351	(39.6)	3.13	III	1	A6100	11	
69.0	847	(95.6)	1.53	II	83.3	701	(79.2)	1.53	II	1	Z6090	21	
			2.02	III				2.02	III	1	Z6095	21	
			3.13	III				3.13	III	1	A6100	21	
51.8	1130	(128)	1.53	II	62.5	935	(106)	1.53	II	1	Z6090	28	
			2.02	III				2.02	III	1	Z6095	28	
			3.13	III				3.13	III	1	A6100	28	
37.7	1550	(175)	1.53	II	45.5	1290	(145)	1.53	II	1	Z6090	39	
			2.02	III				2.02	III	1	Z6095	39	
			3.13	III				3.13	III	1	A6100	39	
31.9	1830	(207)	1.53	II	38.5	1520	(172)	1.53	II	1	Z6090	46	
			2.02	III				2.02	III	1	Z6095	46	
			3.13	III				3.13	III	1	A6100	46	
27.6	2120	(239)	1.53	II	33.3	1750	(198)	1.53	II	1	Z6090	53	
			1.85	II				2.02	III	1	Z6095	53	
			3.13	III				3.13	III	1	A6100	53	
24.4	2400	(271)	1.53	II	29.4	1990	(225)	1.53	II	1	Z6090	60	
			1.63	II				1.97	II	1	Z6095	60	
			2.65	III				2.65	III	1	A6100	60	
19.7	2960	(335)	1.01	I	23.8	2450	(277)	1.01	I	1	Z6090	74	
			1.32	I				1.59	II	1	Z6095	74	
			2.53	III				2.57	III	1	A6100	74	
			2.64	III				3.11	III	1	A6105	74	
16.6	3530	(399)	0.89	-	20.0	2920	(330)	0.89	-	1	Z6090	88	
			1.11	I				1.16	I	1	Z6095	88	
			1.69	II				1.69	II	1	A6100	88	
			2.22	III				2.23	III	1	A6105	88	
14.3	4090	(462)	0.83	-	17.2	3390	(383)	0.83	-	1	Z6090	102	
			0.95	-				1.04	I	1	Z6095	102	
			1.61	II				1.61	II	1	A6100	102	
			1.91	II				2.12	III	1	A6105	102	
11.8	4940	(558)	0.79	-	14.3	4090	(462)	0.82	-	1	Z6090	123	
			0.79	-				0.95	-	1	Z6095	123	
			1.30	I				1.30	I	1	A6100	123	
			1.58	II				1.60	II	1	A6105	123	
			3.16	III				3.32	III	1	B6120	123	
			3.17	III				3.83	III	1	B6125	123	

Notes: [1] Variable Frequency Drive (VFD) notes (see page 3.8 for Constant Torque Speed Ranges):
 (-) = For Inverter Operation, starting condition may require ambient temperature of 5° C or higher.
 (a) = Both AV and non-AV motors can be used for selection.

Single Reduction Selection Tables: Y1, Y2, Y3, Y4

**1 HP
(0.75 kW)**

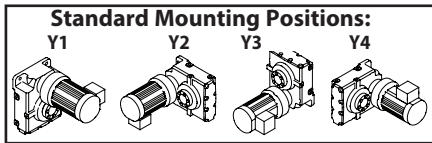

Selection Table Pages:

Single Reduction	3.10-3.38
-Y1,Y2,Y3,Y4	3.10-3.38
-Y5,Y6	3.39-3.61
Double Reduction	3.62-3.79
-Y1,Y2,Y3,Y4,Y5,Y6	3.62-3.79

Dimension Pages:

Single Reduction	3.80-3.85
Double Reduction	3.86-3.91

Frequency	50 Hz	60 Hz
Input Speed	1450 RPM	1750 RPM
Number of Poles	4	

50Hz				60 Hz				Selection					
Output Speed (RPM)	Output Torque		Service Factor		Output Speed (RPM)	Output Torque		Service Factor		Base		VFD ^[1]	
	in-lbs	(N·m)	SF	AGMA Class		in-lbs	(N·m)	SF	AGMA Class	Motor Power Code	Frame Size		Ratio
9.63	6070	(685)	1.04	I	11.6	5030	(568)	1.04	I	1	A6100	151	
			1.29	I				1	A6105	151			
			2.55	III				1	B6120	151			
			2.58	III				1	B6125	151			
8.12	7200	(813)	1.03	I	9.80	5960	(674)	1.03	I	1	A6105	179	
			2.17	III				1	B6120	179			
			2.18	III				1	B6125	179			
7.02	8320	(940)	0.91	-	8.47	6900	(779)	0.94	-	1	A6105	207	
			1.73	II				1	B6120	207			
			1.88	II				1	B6125	207			
5.84	10000	(1130)	1.28	I	7.04	8300	(938)	1.28	I	1	B6120	249	
			1.52	II				1	B6125	249			
			3.13	III				1	C6140	249			
			3.13	III				1	C6145	249			
4.76	12300	(1390)	1.26	I	5.75	10200	(1150)	1.26	I	1	B6120	305	
			1.28	I				1	B6125	305			
			2.55	III				1	C6140	305			
			2.55	III				1	C6145	305			

Cyclo® HBB

Selection
Tables

Notes: [1] Variable Frequency Drive (VFD) notes (see page 3.8 for Constant Torque Speed Ranges):

(-) = For Inverter Operation, starting condition may require ambient temperature of 5° C or higher.

(a) = Both AV and non-AV motors can be used for selection.

Single Reduction Selection Tables: Y1, Y2, Y3, Y4

**1.5 HP
(1.1 kW)**

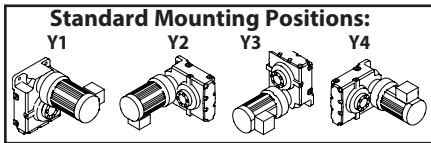

Selection Table Pages:
 Single Reduction
 -Y1,Y2,Y3,Y4 3.10-3.38
 -Y5,Y6 3.39-3.61
 Double Reduction
 -Y1,Y2,Y3,Y4,Y5,Y6 3.62-3.79

Dimension Pages:
 Single Reduction 3.80-3.85
 Double Reduction 3.86-3.91

Frequency	50 Hz	60 Hz
Input Speed	1450 RPM	1750 RPM
Number of Poles	4	

50Hz					60 Hz					Selection			VFD ^[1]
Output Speed (RPM)	Output Torque		Service Factor		Output Speed (RPM)	Output Torque		Service Factor		Base			
	in-lbs	(N·m)	SF	AGMA Class		in-lbs	(N·m)	SF	AGMA Class	Motor Power Code	Frame Size	Ratio	
138	621	(70.1)	2.14	III	167	514	(58.1)	2.14	III	1H	A6100	11	
			2.89	III				1H	A6105	11			
82.9	1030	(117)	2.23	III	100	857	(96.9)	2.23	III	1H	A6100	18	
			3.01	III				1H	A6105	18			
69.0	1240	(140)	1.04	I	83.3	1030	(116)	1.04	I	1H	Z6090	21	
			1.38	I				1H	Z6095	21			
			2.13	III				1H	A6100	21			
			2.89	III				1H	A6105	21			
51.8	1660	(187)	1.04	I	62.5	1370	(155)	1.04	I	1H	Z6090	28	
			1.38	I				1H	Z6095	28			
			2.13	III				1H	A6100	28			
			2.89	III				1H	A6105	28			
37.7	2280	(257)	1.04	I	45.5	1890	(213)	1.04	I	1H	Z6090	39	
			1.38	I				1H	Z6095	39			
			2.13	III				1H	A6100	39			
			2.89	III				1H	A6105	39			
31.9	2690	(304)	1.04	I	38.5	2230	(252)	1.04	I	1H	Z6090	46	
			1.38	I				1H	Z6095	46			
			2.13	III				1H	A6100	46			
			2.89	III				1H	A6105	46			
27.6	3100	(351)	1.04	I	33.3	2570	(291)	1.04	I	1H	Z6090	53	
			1.26	I				1H	Z6095	53			
			2.13	III				1H	A6100	53			
			2.52	III				1H	A6105	53			
24.4	3520	(397)	1.04	I	29.4	2910	(329)	1.04	I	1H	Z6090	60	
			1.11	I				1H	Z6095	60			
			1.81	II				1H	A6100	60			
			2.22	III				1H	A6105	60			
19.7	4350	(491)	0.90	-	23.8	3600	(407)	1.08	I	1H	Z6095	74	
			1.73	II				1H	A6100	74			
			1.80	II				1H	A6105	74			
16.6	5170	(584)	1.15	I	20.0	4290	(484)	1.15	I	1H	A6100	88	
			1.51	II				1H	A6105	88			
			2.81	III				1H	B6120	88			
			3.03	III				1H	B6125	88			

Notes: [1] Variable Frequency Drive (VFD) notes (see page 3.8 for Constant Torque Speed Ranges):
 (-) = For Inverter Operation, starting condition may require ambient temperature of 5° C or higher.
 (a) = Both AV and non-AV motors can be used for selection.

Single Reduction Selection Tables: Y1, Y2, Y3, Y4

1.5 HP
(1.1 kW)

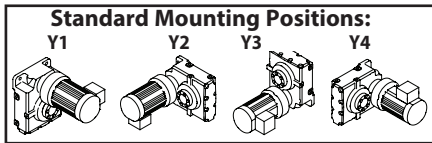

Selection Table Pages:

Single Reduction	3.10-3.38
-Y1,Y2,Y3,Y4	3.10-3.38
-Y5,Y6	3.39-3.61
Double Reduction	3.62-3.79
-Y1,Y2,Y3,Y4,Y5,Y6	3.62-3.79

Dimension Pages:

Single Reduction	3.80-3.85
Double Reduction	3.86-3.91

Frequency	50 Hz	60 Hz
Input Speed	1450 RPM	1750 RPM
Number of Poles	4	

50Hz					60 Hz					Selection			
Output Speed (RPM)	Output Torque		Service Factor		Output Speed (RPM)	Output Torque		Service Factor		Motor Power Code	Base		VFD ^[1]
	in-lbs	(N·m)	SF	AGMA Class		in-lbs	(N·m)	SF	AGMA Class		Frame Size	Ratio	
14.3	6000	(678)	1.10	I	17.2	4970	(562)	1.10	I	1H	A6100	102	
			1.30	I				1.45	II		A6105	102	
			2.61	III				2.72	III		B6120	102	
			2.61	III				3.15	III		B6125	102	
11.8	7240	(818)	0.89	-	14.3	6000	(678)	0.89	-	1H	A6100	123	
			1.08	I				1.09	I		A6105	123	
			2.15	III				2.26	III		B6120	123	
			2.16	III				2.61	III		B6125	123	
9.63	8900	(1010)	0.88	-	11.6	7370	(833)	0.98	-	1H	A6105	151	
			1.74	II				1.74	II		B6120	151	
			1.76	II				2.12	III		B6125	151	
8.12	10600	(1190)	1.48	II	9.80	8740	(988)	1.56	II	1H	B6120	179	
			1.48	II				1.79	II		B6125	179	
			2.97	III				3.12	III		C6140	179	
			2.97	III				3.58	III		C6145	179	
7.02	12200	(1380)	1.18	I	8.47	10100	(1140)	1.18	I	1H	B6120	207	
			1.28	I				1.47	II		B6125	207	
			2.57	III				2.69	III		C6140	207	
			2.57	III				3.10	III		C6145	207	
5.84	14700	(1660)	0.87	-	7.04	12200	(1380)	0.87	-	1H	B6120	249	
			1.03	I				1.09	I		B6125	249	
			2.13	III				2.21	III		C6140	249	
			2.13	III				2.57	III		C6145	249	
			3.15	III				3.15	III		D6160	249	
4.76	18000	(2030)	0.86	-	5.75	14900	(1690)	0.86	-	1H	B6120	305	
			0.87	-				1.03	I		B6125	305	
			1.74	II				1.80	II		C6140	305	
			1.74	II				2.10	III		C6145	305	
			2.93	III				3.15	III		D6160	305	
			3.05	III				3.54	III		D6165	305	

Cyclo® HBB

Selection
Tables

Notes: [1] Variable Frequency Drive (VFD) notes (see page 3.8 for Constant Torque Speed Ranges):
 (-) = For Inverter Operation, starting condition may require ambient temperature of 5° C or higher.
 (a) = Both AV and non-AV motors can be used for selection.

Single Reduction Selection Tables: Y1, Y2, Y3, Y4

**2 HP
(1.5 kW)**

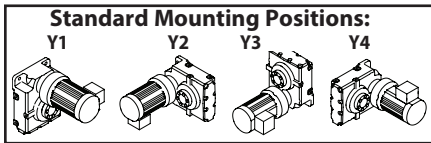

Selection Table Pages:
 Single Reduction
 -Y1,Y2,Y3,Y4 3.10-3.38
 -Y5,Y6 3.39-3.61
 Double Reduction
 -Y1,Y2,Y3,Y4,Y5,Y6 3.62-3.79

Dimension Pages:
 Single Reduction 3.80-3.85
 Double Reduction 3.86-3.91

Frequency	50 Hz	60 Hz
Input Speed	1450 RPM	1750 RPM
Number of Poles	4	

50Hz					60 Hz					Selection			
Output Speed (RPM)	Output Torque		Service Factor		Output Speed (RPM)	Output Torque		Service Factor		Motor Power Code	Base		VFD ^[1]
	in·lbs	(N·m)	SF	AGMA Class		in·lbs	(N·m)	SF	AGMA Class		Frame Size	Ratio	
138	847	(95.6)	1.57	II	167	701	(79.2)	1.57	II	2	A6100	11	
			2.12	III				2.12	III		A6105	11	
82.9	1410	(159)	1.63	II	100	1170	(132)	1.63	II	2	A6100	18	
			2.21	III				2.21	III		A6105	18	
69.0	1690	(191)	1.01	I	83.3	1400	(158)	1.01	I	2	Z6095	21	
			1.56	II				1.56	II		A6100	21	
			2.12	III				2.12	III		A6105	21	
51.8	2260	(255)	1.01	I	62.5	1870	(211)	1.01	I	2	Z6095	28	
			1.56	II				1.56	II		A6100	28	
			2.12	III				2.12	III		A6105	28	
37.7	3100	(351)	1.01	I	45.5	2570	(291)	1.01	I	2	Z6095	39	
			1.56	II				1.56	II		A6100	39	
			2.12	III				2.12	III		A6105	39	
31.9	3670	(414)	1.01	I	38.5	3040	(343)	1.01	I	2	Z6095	46	
			1.56	II				1.56	II		A6100	46	
			2.12	III				2.12	III		A6105	46	
27.6	4230	(478)	0.92	-	33.3	3510	(396)	1.01	I	2	Z6095	53	
			1.56	II				1.56	II		A6100	53	
			1.85	II				2.12	III		A6105	53	
24.4	4800	(542)	0.81	-	29.4	3970	(449)	0.98	-	2	Z6095	60	
			1.32	I				1.32	I		A6100	60	
			1.63	II				1.64	II		A6105	60	
19.7	5930	(669)	0.66	-	23.8	4910	(555)	0.80	-	2	Z6095	74	
			1.27	I				1.28	I		A6100	74	
			1.32	I				1.56	II		A6105	74	
			2.64	III				2.64	III		B6120	74	
			2.64	III				3.19	III		B6125	74	
16.6	7050	(797)	0.85	-	20.0	5840	(660)	0.85	-	2	A6100	88	
			1.11	I				1.11	I		A6105	88	
			2.06	III				2.06	III		B6120	88	
			2.22	III				2.64	III		B6125	88	
14.3	8180	(925)	0.81	-	17.2	6780	(766)	0.81	-	2	A6100	102	
			0.96	-				1.06	I		A6105	102	
			1.91	II				1.99	II		B6120	102	
			1.91	II				2.31	III		B6125	102	

Notes: [1] Variable Frequency Drive (VFD) notes (see page 3.8 for Constant Torque Speed Ranges):
 (-) = For Inverter Operation, starting condition may require ambient temperature of 5° C or higher.
 (a) = Both AV and non-AV motors can be used for selection.

Single Reduction Selection Tables: Y1, Y2, Y3, Y4

**2 HP
(1.5 kW)**

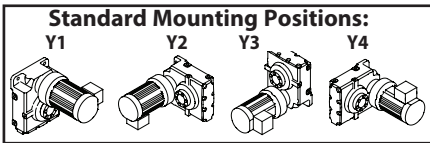

Selection Table Pages:

Single Reduction	
-Y1,Y2,Y3,Y4	3.10-3.38
-Y5,Y6	3.39-3.61
Double Reduction	
-Y1,Y2,Y3,Y4,Y5,Y6	3.62-3.79

Dimension Pages:

Single Reduction	3.80-3.85
Double Reduction	3.86-3.91

Frequency	50 Hz	60 Hz
Input Speed	1450 RPM	1750 RPM
Number of Poles	4	

50Hz					60 Hz					Selection			
Output Speed (RPM)	Output Torque		Service Factor		Output Speed (RPM)	Output Torque		Service Factor		Motor Power Code	Base		VFD ^[1]
	in-lbs	(N·m)	SF	AGMA Class		in-lbs	(N·m)	SF	AGMA Class		Frame Size	Ratio	
11.8	9880	(1120)	0.79	-	14.3	8180	(925)	0.80	-	2	A6105	123	
			1.58	II				1.66	II		B6120	123	
			1.59	II				1.91	II		B6125	123	
			3.17	III				3.47	III		C6140	123	
			3.17	III				3.83	III		C6145	123	
9.63	12100	(1370)	1.27	I	11.6	10100	(1140)	1.27	I	2	B6120	151	
			1.29	I				1.56	II		B6125	151	
			2.58	III				2.63	III		C6140	151	
			2.58	III				3.12	III		C6145	151	
8.12	14400	(1630)	1.09	I	9.80	11900	(1350)	1.14	I	2	B6120	179	
			1.09	I				1.31	I		B6125	179	
			2.18	III				2.29	III		C6140	179	
			2.18	III				2.63	III		C6145	179	
7.02	16600	(1880)	0.87	-	8.47	13800	(1560)	0.87	-	2	B6120	207	
			0.94	-				1.08	I		B6125	207	
			1.88	II				1.97	II		C6140	207	
			1.88	II				2.27	III		C6145	207	
			2.95	III				2.95	III		D6160	207	
5.84	20000	(2260)	0.76	-	7.04	16600	(1880)	0.80	-	2	B6125	249	
			1.56	II				1.62	II		C6140	249	
			1.56	II				1.89	II		C6145	249	
			2.31	III				2.31	III		D6160	249	
			2.74	III				3.31	III		D6165	249	
4.76	24500	(2770)	1.28	I	5.75	20300	(2300)	1.32	I	2	C6140	305	
			1.28	I				1.54	II		C6145	305	
			2.15	III				2.31	III		D6160	305	
			2.24	III				2.60	III		D6165	305	

Cyclo® HBB

Selection
Tables

Notes: [1] Variable Frequency Drive (VFD) notes (see page 3.8 for Constant Torque Speed Ranges):

(-) = For Inverter Operation, starting condition may require ambient temperature of 5° C or higher.

(a) = Both AV and non-AV motors can be used for selection.

Single Reduction Selection Tables: Y1, Y2, Y3, Y4

**3 HP
(2.2 kW)**

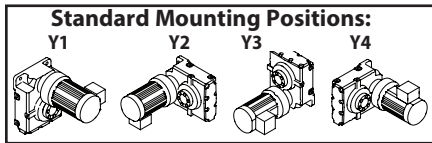

Selection Table Pages:
 Single Reduction
 -Y1,Y2,Y3,Y4 3.10-3.38
 -Y5,Y6 3.39-3.61
 Double Reduction
 -Y1,Y2,Y3,Y4,Y5,Y6 3.62-3.79

Dimension Pages:
 Single Reduction 3.80-3.85
 Double Reduction 3.86-3.91

Frequency	50 Hz	60 Hz
Input Speed	1450 RPM	1750 RPM
Number of Poles	4	

50Hz				60 Hz				Selection					
Output Speed (RPM)	Output Torque		Service Factor		Output Speed (RPM)	Output Torque		Service Factor		Base		VFD ^[1]	
	in-lbs	(N·m)	SF	AGMA Class		in-lbs	(N·m)	SF	AGMA Class	Motor Power Code	Frame Size		Ratio
138	1240	(140)	1.07	I	167	1030	(116)	1.07	I	3	A6100	11	
			1.45	II				3	A6105	11			
			2.30	III				3	B6120	11			
			2.82	III				3	B6125	11			
82.9	2070	(234)	1.11	I	100	1710	(194)	1.11	I	3	A6100	18	
			1.51	II				3	A6105	18			
			2.35	III				3	B6120	18			
			2.88	III				3	B6125	18			
69.0	2480	(281)	1.07	I	83.3	2060	(232)	1.07	I	3	A6100	21	
			1.45	II				3	A6105	21			
			2.30	III				3	B6120	21			
			3.16	III				3	B6125	21			
51.8	3310	(374)	1.07	I	62.5	2740	(310)	1.07	I	3	A6100	28	
			1.45	II				3	A6105	28			
			2.30	III				3	B6120	28			
			3.16	III				3	B6125	28			
37.7	4550	(514)	1.07	I	45.5	3770	(426)	1.07	I	3	A6100	39	
			1.45	II				3	A6105	39			
			2.30	III				3	B6120	39			
			2.69	III				3	B6125	39			
31.9	5380	(608)	1.07	I	38.5	4460	(504)	1.07	I	3	A6100	46	
			1.45	II				3	A6105	46			
			2.30	III				3	B6120	46			
			2.69	III				3	B6125	46			
27.6	6210	(701)	1.07	I	33.3	5140	(581)	1.07	I	3	A6100	53	
			1.26	I				3	A6105	53			
			2.30	III				3	B6120	53			
			2.52	III				3	B6125	53			
24.4	7040	(795)	0.90	-	29.4	5830	(659)	0.90	-	3	A6100	60	
			1.11	I				3	A6105	60			
			2.22	III				3	B6120	60			
			2.23	III				3	B6125	60			
19.7	8690	(982)	0.86	-	23.8	7200	(814)	0.88	-	3	A6100	74	
			0.90	-				3	A6105	74			
			1.80	II				3	B6120	74			
			1.80	II				3	B6125	74			

Notes: [1] Variable Frequency Drive (VFD) notes (see page 3.8 for Constant Torque Speed Ranges):
 (-) = For Inverter Operation, starting condition may require ambient temperature of 5° C or higher.
 (a) = Both AV and non-AV motors can be used for selection.

Single Reduction Selection Tables: Y1, Y2, Y3, Y4

**3 HP
(2.2 kW)**

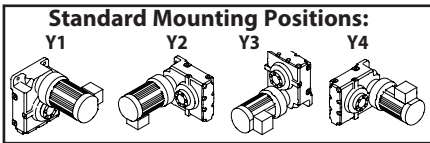

Selection Table Pages:

Single Reduction	3.10-3.38
-Y1,Y2,Y3,Y4	3.10-3.38
-Y5,Y6	3.39-3.61
Double Reduction	3.62-3.79
-Y1,Y2,Y3,Y4,Y5,Y6	3.62-3.79

Dimension Pages:

Single Reduction	3.80-3.85
Double Reduction	3.86-3.91

Frequency	50 Hz	60 Hz
Input Speed	1450 RPM	1750 RPM
Number of Poles	4	

50Hz				60 Hz				Selection			VFD ^[1]	
Output Speed (RPM)	Output Torque		Service Factor		Output Speed (RPM)	Output Torque		Base		Ratio		
	in-lbs	(N·m)	SF	AGMA Class		in-lbs	(N·m)	SF	AGMA Class			Motor Power Code
16.6	10300	(1170)	1.40	II	20.0	8570	(969)	1.40	II	3	B6120	88
			1.51	II				3	B6125	88		
			3.03	III				3	C6140	88		
			3.03	III				3	C6145	88		
14.3	12000	(1360)	1.30	I	17.2	9940	(1120)	1.36	I	3	B6120	102
			1.31	I				3	B6125	102		
			2.61	III				3	C6140	102		
			2.61	III				3	C6145	102		
11.8	14500	(1640)	1.08	I	14.3	12000	(1360)	1.13	I	3	B6120	123
			1.08	I				3	B6125	123		
			2.16	III				3	C6140	123		
			2.16	III				3	C6145	123		
9.63	17800	(2010)	0.87	-	11.6	14700	(1670)	0.87	-	3	B6120	151
			0.88	-				3	B6125	151		
			1.76	II				3	C6140	151		
			1.76	II				3	C6145	151		
			2.93	III				3	D6160	151		
			3.08	III				3	D6165	151		
8.12	21100	(2380)	0.74	-	9.80	17500	(1980)	0.90	-	3	B6125	179
			1.48	II				3	C6140	179		
			1.48	II				3	C6145	179		
			2.50	III				3	D6160	179		
			2.60	III				3	D6165	179		
7.02	24400	(2760)	1.28	I	8.47	20200	(2290)	1.35	I	3	C6140	207
			1.28	I				3	C6145	207		
			2.01	III				3	D6160	207		
			2.25	III				3	D6165	207		
			3.01	III				3	E6170	207		
			3.14	III				3	E6175	207		
5.84	29400	(3320)	1.07	I	7.04	24300	(2750)	1.10	I	3	C6140	249
			1.07	I				3	C6145	249		
			1.58	II				3	D6160	249		
			1.87	II				3	D6165	249		
			2.50	III				3	E6170	249		
			2.61	III				3	E6175	249		

Cyclo® HBB

Selection
Tables

Notes: [1] Variable Frequency Drive (VFD) notes (see page 3.8 for Constant Torque Speed Ranges):
 (-) = For Inverter Operation, starting condition may require ambient temperature of 5° C or higher.
 (a) = Both AV and non-AV motors can be used for selection.

Single Reduction Selection Tables: Y1, Y2, Y3, Y4

**3 HP
(2.2 kW)**

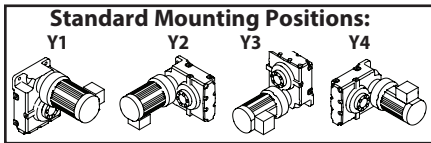

Selection Table Pages:

Single Reduction	
-Y1,Y2,Y3,Y4	3.10-3.38
-Y5,Y6	3.39-3.61
Double Reduction	
-Y1,Y2,Y3,Y4,Y5,Y6	3.62-3.79

Dimension Pages:

Single Reduction	3.80-3.85
Double Reduction	3.86-3.91

Frequency	50 Hz	60 Hz
Input Speed	1450 RPM	1750 RPM
Number of Poles	4	

Output Speed (RPM)	50Hz				60 Hz				Selection			VFD ^[1]
	Output Torque		Service Factor		Output Torque		Service Factor		Base			
	in·lbs	(N·m)	SF	AGMA Class	in·lbs	(N·m)	SF	AGMA Class	Motor Power Code	Frame Size	Ratio	
4.76	36000 (4070)		0.87	-	5.75	29800 (3370)		0.90	-	3	C6140	305
			0.87	-				1.05	I	3	C6145	305
			1.47	II				1.58	II	3	D6160	305
			1.52	II				1.77	II	3	D6165	305
			2.08	III				2.19	III	3	E6170	305
			2.13	III				2.57	III	3	E6175	305

Cyclo® HBB

Selection
Tables

Notes: [1] Variable Frequency Drive (VFD) notes (see page 3.8 for Constant Torque Speed Ranges):

(-) = For Inverter Operation, starting condition may require ambient temperature of 5° C or higher.

(a) = Both AV and non-AV motors can be used for selection.

Single Reduction Selection Tables: Y1, Y2, Y3, Y4

**5 HP
(3.7 kW)**

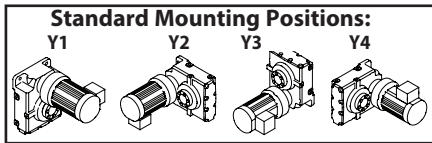

Selection Table Pages:
 Single Reduction -Y1,Y2,Y3,Y4 3.10-3.38
 -Y5,Y6 3.39-3.61
 Double Reduction -Y1,Y2,Y3,Y4,Y5,Y6 3.62-3.79

Dimension Pages:
 Single Reduction 3.80-3.85
 Double Reduction 3.86-3.91

Frequency	50 Hz	60 Hz
Input Speed	1450 RPM	1750 RPM
Number of Poles	4	

50Hz				60 Hz				Selection					
Output Speed (RPM)	Output Torque		Service Factor		Output Speed (RPM)	Output Torque		Service Factor		Base		VFD ^[1]	
	in-lbs	(N·m)	SF	AGMA Class		in-lbs	(N·m)	SF	AGMA Class	Motor Power Code	Frame Size		Ratio
138	2090	(236)	1.37	I	167	1730	(195)	1.37	I	5	B6120	11	
			1.68	II				5	B6125	11			
82.9	3480	(393)	1.40	II	100	2880	(326)	1.40	II	5	B6120	18	
			1.71	II				5	B6125	18			
69.0	4180	(472)	1.37	I	83.3	3460	(391)	1.37	I	5	B6120	21	
			1.88	II				5	B6125	21			
51.8	5570	(629)	1.37	I	62.5	4610	(521)	1.37	I	5	B6120	28	
			1.88	II				5	B6125	28			
37.7	7660	(865)	1.37	I	45.5	6340	(717)	1.37	I	5	B6120	39	
			1.60	II				5	B6125	39			
31.9	9050	(1020)	1.37	I	38.5	7500	(847)	1.37	I	5	B6120	46	
			1.60	II				5	B6125	46			
27.6	10400	(1180)	1.37	I	33.3	8650	(977)	1.37	I	5	B6120	53	
			1.50	II				5	B6125	53			
			3.00	III				5	C6140	53			
			3.00	III				5	C6145	53			
24.4	11800	(1340)	1.32	I	29.4	9800	(1110)	1.37	I	5	B6120	60	
			1.32	I				5	B6125	60			
			2.65	III				5	C6140	60			
			2.65	III				5	C6145	60			
19.7	14600	(1650)	1.07	I	23.8	12100	(1370)	1.07	I	5	B6120	74	
			1.07	I				5	B6125	74			
			2.14	III				5	C6140	74			
			2.14	III				5	C6145	74			
16.6	17400	(1970)	0.83	-	20.0	14400	(1630)	0.83	-	5	B6120	88	
			0.90	-				5	B6125	88			
			1.80	II				5	C6140	88			
			1.80	II				5	C6145	88			
			2.67	III				5	D6160	88			
			3.15	III				5	D6165	88			
14.3	20200	(2280)	0.77	-	17.2	16700	(1890)	0.81	-	5	B6120	102	
			0.78	-				5	B6125	102			
			1.55	II				5	C6140	102			
			1.55	II				5	C6145	102			
			2.58	III				5	D6160	102			
			2.72	III				5	D6165	102			

Cyclo® HBB

Selection
Tables

Notes: [1] Variable Frequency Drive (VFD) notes (see page 3.8 for Constant Torque Speed Ranges):
 (-) = For Inverter Operation, starting condition may require ambient temperature of 5° C or higher.
 (a) = Both AV and non-AV motors can be used for selection.

Single Reduction Selection Tables: Y1, Y2, Y3, Y4

**5 HP
(3.7 kW)**

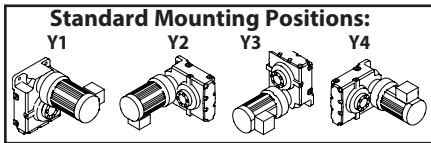

Selection Table Pages:
 Single Reduction
 -Y1,Y2,Y3,Y4 3.10-3.38
 -Y5,Y6 3.39-3.61
 Double Reduction
 -Y1,Y2,Y3,Y4,Y5,Y6 3.62-3.79

Dimension Pages:
 Single Reduction 3.80-3.85
 Double Reduction 3.86-3.91

Frequency	50 Hz	60 Hz
Input Speed	1450 RPM	1750 RPM
Number of Poles	4	

50Hz				60 Hz				Selection					
Output Speed (RPM)	Output Torque		Service Factor		Output Speed (RPM)	Output Torque		Service Factor		Base		VFD ^[1]	
	in-lbs	(N·m)	SF	AGMA Class		in-lbs	(N·m)	SF	AGMA Class	Motor Power Code	Frame Size		Ratio
11.8	24400	(2750)	1.29	I	14.3	20200	(2280)	1.41	II	5	C6140	123	(-)
			1.29	I				1.55	II	5	C6145	123	
			2.17	III				2.61	III	5	D6160	123	
			2.25	III				2.72	III	5	D6165	123	
			3.02	III				3.24	III	5	E6170	123	
			3.14	III				3.79	III	5	E6175	123	
9.63	29900	(3380)	1.05	I	11.6	24800	(2800)	1.06	I	5	C6140	151	
			1.05	I				1.26	I	5	C6145	151	
			1.74	II				2.01	III	5	D6160	151	
			1.83	II				2.14	III	5	D6165	151	
			2.45	III				2.64	III	5	E6170	151	
			2.56	III				3.05	III	5	E6175	151	
8.12	35500	(4010)	0.88	-	9.80	29400	(3320)	0.93	-	5	C6140	179	
			0.88	-				1.07	I	5	C6145	179	
			1.49	II				1.55	II	5	D6160	179	
			1.55	II				1.87	II	5	D6165	179	
			2.07	III				2.27	III	5	E6170	179	
			2.16	III				2.60	III	5	E6175	179	
7.02	41100	(4640)	0.76	-	8.47	34000	(3840)	0.80	-	5	C6140	207	
			0.76	-				0.92	-	5	C6145	207	
			1.19	I				1.19	I	5	D6160	207	
			1.34	I				1.55	II	5	D6165	207	
			1.79	II				1.93	II	5	E6170	207	
			1.86	II				2.25	III	5	E6175	207	
5.84	49400	(5580)	0.94	-	7.04	40900	(4630)	0.94	-	5	D6160	249	
			1.11	I				1.34	I	5	D6165	249	
			1.49	II				1.60	II	5	E6170	249	
			1.55	II				1.87	II	5	E6175	249	
4.76	60600	(6840)	0.87	-	5.75	50200	(5670)	0.94	-	5	D6160	305	
			0.91	-				1.05	I	5	D6165	305	
			1.23	I				1.30	I	5	E6170	305	
			1.26	I				1.53	II	5	E6175	305	

Cyclo® HBB

Selection
Tables

Notes: [1] Variable Frequency Drive (VFD) notes (see page 3.8 for Constant Torque Speed Ranges):

(-) = For Inverter Operation, starting condition may require ambient temperature of 5° C or higher.

(a) = Both AV and non-AV motors can be used for selection.

Single Reduction Selection Tables: Y1, Y2, Y3, Y4

**7.5 HP
(5.5 kW)**

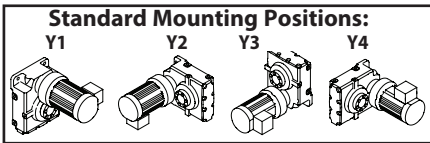

Selection Table Pages:

Single Reduction	3.10-3.38
-Y1,Y2,Y3,Y4	3.10-3.38
-Y5,Y6	3.39-3.61
Double Reduction	3.62-3.79
-Y1,Y2,Y3,Y4,Y5,Y6	3.62-3.79

Dimension Pages:

Single Reduction	3.80-3.85
Double Reduction	3.86-3.91

Frequency	50 Hz	60 Hz
Input Speed	1450 RPM	1750 RPM
Number of Poles	4	

50Hz					60 Hz					Selection			
Output Speed (RPM)	Output Torque		Service Factor		Output Speed (RPM)	Output Torque		Service Factor		Base			VFD ^[1]
	in-lbs	(N·m)	SF	AGMA Class		in-lbs	(N·m)	SF	AGMA Class	Motor Power Code	Frame Size	Ratio	
138	3100	(351)	0.92	-	167	2570	(291)	0.92	-	8	B6120	11	
			1.13	I				8	B6125	11			
			2.28	III				8	C6140	11			
			2.65	III				8	C6145	11			
82.9	5170	(584)	0.94	-	100	4290	(484)	0.94	-	8	B6120	18	
			1.15	I				8	B6125	18			
			2.36	III				8	C6140	18			
			2.75	III				8	C6145	18			
69.0	6210	(701)	0.92	-	83.3	5140	(581)	0.92	-	8	B6120	21	
			1.27	I				8	B6125	21			
			2.36	III				8	C6140	21			
			2.75	III				8	C6145	21			
51.8	8280	(935)	0.92	-	62.5	6860	(775)	0.92	-	8	B6120	28	
			1.26	I				8	B6125	28			
			2.36	III				8	C6140	28			
			2.75	III				8	C6145	28			
37.7	11400	(1290)	0.92	-	45.5	9430	(1070)	0.92	-	8	B6120	39	
			1.08	I				8	B6125	39			
			2.36	III				8	C6140	39			
			2.75	III				8	C6145	39			
31.9	13400	(1520)	0.92	-	38.5	11100	(1260)	0.92	-	8	B6120	46	
			1.08	I				8	B6125	46			
			2.33	III				8	C6140	46			
			2.33	III				8	C6145	46			
27.6	15500	(1750)	0.92	-	33.3	12900	(1450)	0.92	-	8	B6120	53	
			1.01	I				8	B6125	53			
			2.02	III				8	C6140	53			
			2.02	III				8	C6145	53			
24.4	17600	(1990)	0.89	-	29.4	14600	(1650)	0.92	-	8	B6120	60	
			0.89	-				1.03	I	8	B6125	60	
			1.78	II				1.83	II	8	C6140	60	
			1.78	II				2.15	III	8	C6145	60	
			2.37	III				2.37	III	8	D6160	60	
			3.12	III				3.43	III	8	D6165	60	

Notes: [1] Variable Frequency Drive (VFD) notes (see page 3.8 for Constant Torque Speed Ranges):
 (-) = For Inverter Operation, starting condition may require ambient temperature of 5° C or higher.
 (a) = Both AV and non-AV motors can be used for selection.

Single Reduction Selection Tables: Y1, Y2, Y3, Y4

7.5 HP
(5.5 kW)

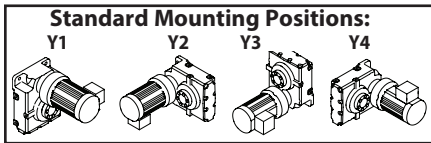

Selection Table Pages:
 Single Reduction
 -Y1,Y2,Y3,Y4 3.10-3.38
 -Y5,Y6 3.39-3.61
 Double Reduction
 -Y1,Y2,Y3,Y4,Y5,Y6 3.62-3.79

Dimension Pages:
 Single Reduction 3.80-3.85
 Double Reduction 3.86-3.91

Frequency	50 Hz	60 Hz
Input Speed	1450 RPM	1750 RPM
Number of Poles	4	

50Hz				60 Hz				Selection					
Output Speed (RPM)	Output Torque		Service Factor		Output Speed (RPM)	Output Torque		Service Factor		Base		VFD ^[1]	
	in-lbs	(N·m)	SF	AGMA Class		in-lbs	(N·m)	SF	AGMA Class	Motor Power Code	Frame Size		Ratio
19.7	21700	(2450)	0.72	-	23.8	18000	(2030)	0.87	-	8	B6125	74	
			1.44	II				8	C6140	74			
			1.44	II				8	C6145	74			
			2.35	III				8	D6160	74			
			2.53	III				8	D6165	74			
16.6	25900	(2920)	1.21	I	20.0	21400	(2420)	1.25	I	8	C6140	88	
			1.21	I				8	C6145	88			
			1.79	II				8	D6160	88			
			2.12	III				8	D6165	88			
			2.83	III				8	E6170	88			
			2.96	III				8	E6175	88			
14.3	30000	(3390)	1.04	I	17.2	24900	(2810)	1.08	I	8	C6140	102	
			1.04	I				8	C6145	102			
			1.74	II				8	D6160	102			
			1.83	II				8	D6165	102			
			2.45	III				8	E6170	102			
			2.55	III				8	E6175	102			
11.8	36200	(4090)	0.87	-	14.3	30000	(3390)	0.95	-	8	C6140	123	
			0.87	-				8	C6145	123			
			1.46	II				8	D6160	123			
			1.52	II				8	D6165	123			
			2.03	III				8	E6170	123			
			2.11	III				8	E6175	123			
9.63	44500	(5030)	0.70	-	11.6	36900	(4160)	0.85	-	8	C6145	151	
			1.17	I				8	D6160	151			
			1.23	I				8	D6165	151			
			1.65	II				8	E6170	151			
			1.72	II				8	E6175	151			
8.12	52800	(5960)	1.00	I	9.80	43700	(4940)	1.05	I	8	D6160	179	
			1.04	I				8	D6165	179			
			1.39	I				8	E6170	179			
			1.45	II				8	E6175	179			
7.02	61000	(6900)	0.80	-	8.47	50600	(5710)	0.80	-	8	D6160	207	
			0.90	-				8	D6165	207			
			1.20	I				8	E6170	207			
			1.25	I				8	E6175	207			

Notes: [1] Variable Frequency Drive (VFD) notes (see page 3.8 for Constant Torque Speed Ranges):
 (-) = For Inverter Operation, starting condition may require ambient temperature of 5° C or higher.
 (a) = Both AV and non-AV motors can be used for selection.

Single Reduction Selection Tables: Y1, Y2, Y3, Y4

**7.5 HP
(5.5 kW)**

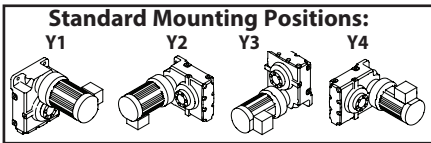

Selection Table Pages:

Single Reduction	
-Y1,Y2,Y3,Y4	3.10-3.38
-Y5,Y6	3.39-3.61
Double Reduction	
-Y1,Y2,Y3,Y4,Y5,Y6	3.62-3.79

Dimension Pages:

Single Reduction	3.80-3.85
Double Reduction	3.86-3.91

Frequency	50 Hz	60 Hz
Input Speed	1450 RPM	1750 RPM
Number of Poles	4	

50Hz		60 Hz		Selection									
Output Speed (RPM)	Output Torque		Service Factor		Output Speed (RPM)	Output Torque		Service Factor		Base			VFD ^[1]
	in-lbs	(N·m)	SF	AGMA Class		in-lbs	(N·m)	SF	AGMA Class	Motor Power Code	Frame Size	Ratio	
5.84	73500 (8300)		0.75	-	7.04	60900 (6880)		0.90	-	8	D6165	249	
			1.00	I				8	E6170	249			
			1.04	I				8	E6175	249			
4.76	90000 (10200)		0.83	-	5.75	74600 (8430)		0.87	-	8	E6170	305	
			0.85	-				8	E6175	305			

Cyclo® HBB

Selection
Tables

Notes: [1] Variable Frequency Drive (VFD) notes (see page 3.8 for Constant Torque Speed Ranges):

(-) = For Inverter Operation, starting condition may require ambient temperature of 5° C or higher.

(a) = Both AV and non-AV motors can be used for selection.

Single Reduction Selection Tables: Y1, Y2, Y3, Y4

**10 HP
(7.5 kW)**

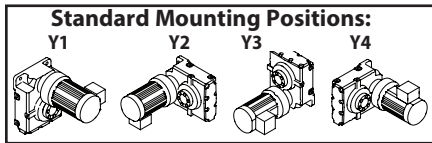

Selection Table Pages:
 Single Reduction
 -Y1,Y2,Y3,Y4 3.10-3.38
 -Y5,Y6 3.39-3.61
 Double Reduction
 -Y1,Y2,Y3,Y4,Y5,Y6 3.62-3.79

Dimension Pages:
 Single Reduction 3.80-3.85
 Double Reduction 3.86-3.91

Frequency	50 Hz	60 Hz
Input Speed	1450 RPM	1750 RPM
Number of Poles	4	

50Hz				60 Hz				Selection					
Output Speed (RPM)	Output Torque		Service Factor		Output Speed (RPM)	Output Torque		Service Factor		Base		VFD ^[1]	
	in-lbs	(N·m)	SF	AGMA Class		in-lbs	(N·m)	SF	AGMA Class	Motor Power Code	Frame Size		Ratio
138	4230	(478)	1.67	II	167	3510	(396)	1.67	II	10	C6140	11	
			1.94	II				10	C6145	11			
			2.64	III				10	D6160	11			
			3.05	III				10	D6165	11			
82.9	7050	(797)	1.73	II	100	5840	(660)	1.73	II	10	C6140	18	
			2.01	III				10	C6145	18			
			2.69	III				10	D6160	18			
			3.10	III				10	D6165	18			
69.0	8470	(956)	1.73	II	83.3	7010	(792)	1.73	II	10	C6140	21	
			2.01	III				10	C6145	21			
51.8	11300	(1280)	0.93	-	62.5	9350	(1060)	0.93	-	10	B6125	28	
			1.73	II				10	C6140	28			
			2.01	III				10	C6145	28			
			2.63	III				10	D6160	28			
37.7	15500	(1750)	1.73	II	45.5	12900	(1450)	1.73	II	10	C6140	39	
			2.01	III				10	C6145	39			
			2.63	III				10	D6160	39			
31.9	18300	(2070)	1.71	II	38.5	15200	(1720)	1.73	II	10	C6140	46	
			1.71	II				10	C6145	46			
			2.63	III				10	D6160	46			
			2.99	III				10	D6165	46			
27.6	21200	(2390)	1.48	II	33.3	17500	(1980)	1.60	II	10	C6140	53	
			1.48	II				10	C6145	53			
			2.49	III				10	D6160	53			
			2.59	III				10	D6165	53			
24.4	24000	(2710)	1.31	I	29.4	19900	(2250)	1.34	I	10	C6140	60	
			1.31	I				10	C6145	60			
			1.74	II				10	D6160	60			
			2.29	III				10	D6165	60			
			2.62	III				10	E6170	60			
3.19	III	10	E6175	60									
19.7	29600	(3350)	1.06	I	23.8	24500	(2770)	1.15	I	10	C6140	74	
			1.06	I				10	C6145	74			
			1.72	II				10	D6160	74			
			1.85	II				10	D6165	74			
			2.48	III				10	E6170	74			
			2.58	III				10	E6175	74			

Notes: [1] Variable Frequency Drive (VFD) notes (see page 3.8 for Constant Torque Speed Ranges):
 (-) = For Inverter Operation, starting condition may require ambient temperature of 5° C or higher.
 (a) = Both AV and non-AV motors can be used for selection.

Single Reduction Selection Tables: Y1, Y2, Y3, Y4

**10 HP
(7.5 kW)**

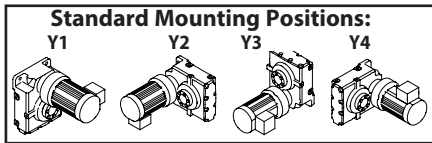

Selection Table Pages:

Single Reduction	3.10-3.38
-Y1,Y2,Y3,Y4	3.10-3.38
-Y5,Y6	3.39-3.61
Double Reduction	3.62-3.79
-Y1,Y2,Y3,Y4,Y5,Y6	3.62-3.79

Dimension Pages:

Single Reduction	3.80-3.85
Double Reduction	3.86-3.91

Frequency	50 Hz	60 Hz
Input Speed	1450 RPM	1750 RPM
Number of Poles	4	

50Hz				60 Hz				Selection					
Output Speed (RPM)	Output Torque		Service Factor		Output Speed (RPM)	Output Torque		Service Factor		Base		VFD ^[1]	
	in-lbs	(N·m)	SF	AGMA Class		in-lbs	(N·m)	SF	AGMA Class	Motor Power Code	Frame Size		Ratio
16.6	35300 (3990)		0.89	-	20.0	29200 (3300)		0.92	-	10	C6140	88	
			0.89	-				1.05	I	10	C6145	88	
			1.32	I				1.32	I	10	D6160	88	
			1.56	II				1.88	II	10	D6165	88	
			2.08	III				2.11	III	10	E6170	88	
			2.17	III				2.62	III	10	E6175	88	
14.3	40900 (4620)		0.77	-	17.2	33900 (3830)		0.92	-	10	C6145	102	
			1.27	I				1.40	II	10	D6160	102	
			1.34	I				1.52	II	10	D6165	102	
			1.79	II				1.91	II	10	E6170	102	
			1.87	II				2.26	III	10	E6175	102	
11.8	49400 (5580)		1.07	I	14.3	40900 (4620)		1.29	I	10	D6160	123	
			1.11	I				1.34	I	10	D6165	123	
			1.49	II				1.60	II	10	E6170	123	
			1.55	II				1.87	II	10	E6175	123	
9.63	60700 (6850)		0.86	-	11.6	50300 (5680)		0.99	-	10	D6160	151	
			0.90	-				1.05	I	10	D6165	151	
			1.21	I				1.30	I	10	E6170	151	
			1.26	I				1.51	II	10	E6175	151	
8.12	72000 (8130)		0.76	-	9.80	59600 (6740)		0.92	-	10	D6165	179	
			1.02	I				1.12	I	10	E6170	179	
			1.06	I				1.28	I	10	E6175	179	
7.02	83200 (9400)		0.88	-	8.47	69000 (7790)		0.95	-	10	E6170	207	
			0.92	-				1.11	I	10	E6175	207	
5.84	100000 (11300)		0.76	-	7.04	83000 (9380)		0.92	-	10	E6175	249	

Notes: [1] Variable Frequency Drive (VFD) notes (see page 3.8 for Constant Torque Speed Ranges):
 (-) = For Inverter Operation, starting condition may require ambient temperature of 5° C or higher.
 (a) = Both AV and non-AV motors can be used for selection.

Single Reduction Selection Tables: Y1, Y2, Y3, Y4

**15 HP
(11 kW)**

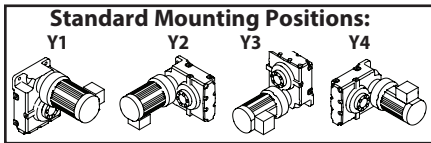

Selection Table Pages:
 Single Reduction
 -Y1,Y2,Y3,Y4 3.10-3.38
 -Y5,Y6 3.39-3.61
 Double Reduction
 -Y1,Y2,Y3,Y4,Y5,Y6 3.62-3.79

Dimension Pages:
 Single Reduction 3.80-3.85
 Double Reduction 3.86-3.91

Frequency	50 Hz	60 Hz
Input Speed	1450 RPM	1750 RPM
Number of Poles	4	

50Hz			60 Hz			Selection			VFD ^[1]			
Output Speed (RPM)	Output Torque		Service Factor	AGMA Class	Output Speed (RPM)	Output Torque		Service Factor		AGMA Class	Base	
	in-lbs	(N·m)				in-lbs	(N·m)		Motor Power Code		Frame Size	Ratio
138	6210	(701)	1.14	I	167	5140	(581)	1.14	I	15	C6140	11
			1.32	I				15	C6145	11		
			1.80	II				15	D6160	11		
			2.08	III				15	D6165	11		
			2.45	III				15	E6170	11		
			2.67	III				15	E6175	11		
82.9	10300	(1170)	1.18	I	100	8570	(969)	1.18	I	15	C6140	18
			1.37	I				15	C6145	18		
			1.83	II				15	D6160	18		
			2.12	III				15	D6165	18		
			2.51	III				15	E6170	18		
			2.73	III				15	E6175	18		
69.0	12400	(1400)	1.18	I	83.3	10300	(1160)	1.18	I	15	C6140	21
			1.37	I				15	C6145	21		
51.8	16600	(1870)	1.18	I	62.5	13700	(1550)	1.18	I	15	C6140	28
			1.37	I				15	C6145	28		
			1.79	II				15	D6160	28		
			2.19	III				15	D6165	28		
37.7	22800	(2570)	1.18	I	45.5	18900	(2130)	1.18	I	15	C6140	39
			1.37	I				15	C6145	39		
			1.79	II				15	D6160	39		
			2.19	III				15	D6165	39		
			2.51	III				15	E6170	39	(-)	
			2.74	III				15	E6175	39	(-)	
31.9	26900	(3040)	1.16	I	38.5	22300	(2520)	1.18	I	15	C6140	46
			1.16	I				15	C6145	46		
			1.79	II				15	D6160	46		
			2.04	III				15	D6165	46		
			2.48	III				15	E6170	46	(-)	
			2.74	III				15	E6175	46	(-)	
27.6	31000	(3510)	1.01	I	33.3	25700	(2910)	1.09	I	15	C6140	53
			1.01	I				15	C6145	53		
			1.70	II				15	D6160	53		
			1.77	II				15	D6165	53		
			2.32	III				15	E6170	53		
			2.32	III				15	E6170	53		
			2.47	III				15	E6175	53		
			2.74	III				15	E6175	53		

Notes: [1] Variable Frequency Drive (VFD) notes (see page 3.8 for Constant Torque Speed Ranges):

(-) = For Inverter Operation, starting condition may require ambient temperature of 5° C or higher.

(a) = Both AV and non-AV motors can be used for selection.

Single Reduction Selection Tables: Y1, Y2, Y3, Y4

**15 HP
(11 kW)**

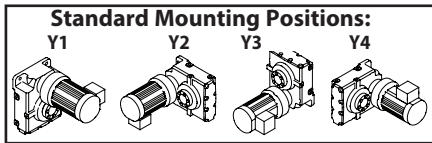

Selection Table Pages:
 Single Reduction -Y1,Y2,Y3,Y4 3.10-3.38
 -Y5,Y6 3.39-3.61
 Double Reduction -Y1,Y2,Y3,Y4,Y5,Y6 3.62-3.79

Dimension Pages:
 Single Reduction 3.80-3.85
 Double Reduction 3.86-3.91

Frequency	50 Hz	60 Hz
Input Speed	1450 RPM	1750 RPM
Number of Poles	4	

50Hz				60 Hz				Selection					
Output Speed (RPM)	Output Torque		Service Factor		Output Speed (RPM)	Output Torque		Service Factor		Base		VFD ^[1]	
	in-lbs	(N·m)	SF	AGMA Class		in-lbs	(N·m)	SF	AGMA Class	Motor Power Code	Frame Size		Ratio
24.4	35200 (3970)		0.89	-	29.4	29100 (3290)		0.92	-	15	C6140	60	
			0.89	-				1.07	I	15	C6145	60	
			1.19	I				1.19	I	15	D6160	60	
			1.56	II				1.71	II	15	D6165	60	
			1.79	II				1.79	II	15	E6170	60	
			2.18	III				2.19	III	15	E6175	60	
19.7	43500 (4910)		0.72	-	23.8	36000 (4070)		0.87	-	15	C6145	74	
			1.17	I				1.17	I	15	D6160	74	
			1.26	I				1.46	II	15	D6165	74	
			1.69	II				1.77	II	15	E6170	74	
			1.76	II				2.13	III	15	E6175	74	
16.6	51700 (5840)		0.90	-	20.0	42900 (4840)		0.90	-	15	D6160	88	
			1.06	I				1.28	I	15	D6165	88	
			1.42	II				1.44	II	15	E6170	88	
			1.48	II				1.79	II	15	E6175	88	
14.3	60000 (6780)		0.87	-	17.2	49700 (5620)		0.95	-	15	D6160	102	
			0.91	-				1.04	I	15	D6165	102	
			1.22	I				1.30	I	15	E6170	102	
			1.28	I				1.54	II	15	E6175	102	
11.8	72400 (8180)		0.73	-	14.3	60000 (6780)		0.88	-	15	D6160	123	
			0.76	-				0.91	-	15	D6165	123	
			1.01	I				1.09	I	15	E6170	123	
			1.06	I				1.28	I	15	E6175	123	
9.63	89000 (10100)		0.83	-	11.6	73700 (8330)		0.89	-	15	E6170	151	
			0.86	-				1.03	I	15	E6175	151	
8.12	106000 (11900)		0.73	-	9.80	87400 (9880)		0.88	-	15	E6175	179	

Cyclo® HBB

Selection
Tables

Notes: [1] Variable Frequency Drive (VFD) notes (see page 3.8 for Constant Torque Speed Ranges):
 (-) = For Inverter Operation, starting condition may require ambient temperature of 5° C or higher.
 (a) = Both AV and non-AV motors can be used for selection.

Single Reduction Selection Tables: Y1, Y2, Y3, Y4

**20 HP
(15 kW)**

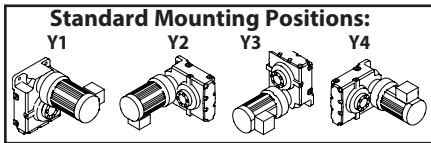

Selection Table Pages:
 Single Reduction
 -Y1,Y2,Y3,Y4 3.10-3.38
 -Y5,Y6 3.39-3.61
 Double Reduction
 -Y1,Y2,Y3,Y4,Y5,Y6 3.62-3.79

Dimension Pages:
 Single Reduction 3.80-3.85
 Double Reduction 3.86-3.91

Frequency	50 Hz	60 Hz
Input Speed	1450 RPM	1750 RPM
Number of Poles	4	

50Hz				60 Hz				Selection					
Output Speed (RPM)	Output Torque		Service Factor		Output Speed (RPM)	Output Torque		Service Factor		Base		VFD ^[1]	
	in-lbs	(N·m)	SF	AGMA Class		in-lbs	(N·m)	SF	AGMA Class	Motor Power Code	Frame Size		Ratio
138	8470	(956)	0.84	-	167	7010	(792)	0.84	-	20	C6140	11	
			0.97	-				20	C6145	11			
			1.32	I				20	D6160	11			
			1.52	II				20	D6165	11			
			1.80	II				20	E6170	11			
			1.96	II				20	E6175	11			
82.9	14100	(1590)	0.87	-	100	11700	(1320)	0.87	-	20	C6140	18	
			1.01	I				20	C6145	18			
			1.35	I				20	D6160	18			
			1.55	II				20	D6165	18			
			1.84	II				20	E6170	18			
			2.00	III				20	E6175	18			
69.0	16900	(1910)	0.87	-	83.3	14000	(1580)	0.87	-	20	C6140	21	
			1.01	I				20	C6145	21			
51.8	22600	(2550)	0.87	-	62.5	18700	(2110)	0.87	-	20	C6140	28	
			1.01	I				20	C6145	28			
			1.31	I				20	D6160	28			
			1.60	II				20	D6165	28			
37.7	31000	(3510)	0.87	-	45.5	25700	(2910)	0.87	-	20	C6140	39	
			1.01	I				20	C6145	39			
			1.31	I				20	D6160	39			
			1.60	II				20	D6165	39			
			1.84	II				20	E6170	39			
			2.01	III				20	E6175	39			
31.9	36700	(4140)	0.85	-	38.5	30400	(3430)	0.87	-	20	C6140	46	
			0.85	-				20	C6145	46			
			1.31	I				20	D6160	46			
			1.50	II				20	D6165	46			
			1.82	II				20	E6170	46			
			2.01	III				20	E6175	46			
27.6	42300	(4780)	0.74	-	33.3	35100	(3960)	0.80	-	20	C6140	53	
			0.74	-				20	C6145	53			
			1.25	I				20	D6160	53			
			1.30	I				20	D6165	53			
			1.70	II				20	E6170	53			
			1.81	II				20	E6175	53			

Notes: [1] Variable Frequency Drive (VFD) notes (see page 3.8 for Constant Torque Speed Ranges):

(-) = For Inverter Operation, starting condition may require ambient temperature of 5° C or higher.

(a) = Both AV and non-AV motors can be used for selection.

Single Reduction Selection Tables: Y1, Y2, Y3, Y4

**20 HP
(15 kW)**

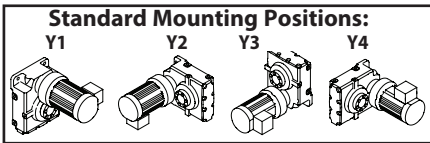

Selection Table Pages:

Single Reduction	
-Y1,Y2,Y3,Y4	3.10-3.38
-Y5,Y6	3.39-3.61
Double Reduction	
-Y1,Y2,Y3,Y4,Y5,Y6	3.62-3.79

Dimension Pages:

Single Reduction	3.80-3.85
Double Reduction	3.86-3.91

Frequency	50 Hz	60 Hz
Input Speed	1450 RPM	1750 RPM
Number of Poles	4	

50Hz				60 Hz				Selection					
Output Speed (RPM)	Output Torque		Service Factor		Output Speed (RPM)	Output Torque		Service Factor		Base		VFD ^[1]	
	in·lbs	(N·m)	SF	AGMA Class		in·lbs	(N·m)	SF	AGMA Class	Motor Power Code	Frame Size		Ratio
24.4	48000	(5420)	0.87	-	29.4	39700	(4490)	0.87	-	20	D6160	60	
			1.14	I				1.26	I	20	D6165	60	
			1.31	I				1.31	I	20	E6170	60	
			1.60	II				1.60	II	20	E6175	60	
19.7	59300	(6690)	0.86	-	23.8	49100	(5550)	0.86	-	20	D6160	74	
			0.93	-				1.07	I	20	D6165	74	
			1.24	I				1.30	I	20	E6170	74	
			1.29	I				1.56	II	20	E6175	74	
16.6	70500	(7970)	0.78	-	20.0	58400	(6600)	0.94	-	20	D6165	88	
			1.04	I				1.05	I	20	E6170	88	
			1.09	I				1.31	I	20	E6175	88	
14.3	81800	(9250)	0.90	-	17.2	67800	(7660)	0.95	-	20	E6170	102	
			0.94	-				1.13	I	20	E6175	102	
11.8	98800	(11200)	0.74	-	14.3	81800	(9250)	0.80	-	20	E6170	123	
			0.78	-				0.94	-	20	E6175	123	

Cyclo® HBB

Selection
Tables

Notes: [1] Variable Frequency Drive (VFD) notes (see page 3.8 for Constant Torque Speed Ranges):

(-) = For Inverter Operation, starting condition may require ambient temperature of 5° C or higher.

(a) = Both AV and non-AV motors can be used for selection.

Single Reduction Selection Tables: Y1, Y2, Y3, Y4

**25 HP
(18.5 kW)**

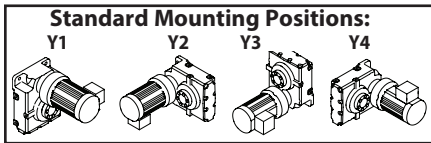

Selection Table Pages:

Single Reduction	
-Y1,Y2,Y3,Y4	3.10-3.38
-Y5,Y6	3.39-3.61
Double Reduction	
-Y1,Y2,Y3,Y4,Y5,Y6	3.62-3.79

Dimension Pages:

Single Reduction	3.80-3.85
Double Reduction	3.86-3.91

Frequency	50 Hz	60 Hz
Input Speed	1450 RPM	1750 RPM
Number of Poles	4	

50Hz				60 Hz				Selection				
Output Speed (RPM)	Output Torque		Service Factor		Output Speed (RPM)	Output Torque		Service Factor		Base		VFD ^[1]
	in-lbs	(N·m)	SF	AGMA Class		in-lbs	(N·m)	SF	AGMA Class	Motor Power Code	Frame Size	
138	10400	(1180)	1.07	I	167	8650	(977)	1.07	I	25	D6160	11
			1.24	I				25	D6165	11		
			1.46	II				25	E6170	11		
			1.59	II				25	E6175	11		
82.9	17400	(1970)	1.09	I	100	14400	(1630)	1.09	I	25	D6160	18
			1.26	I				25	D6165	18		
			1.49	II				25	E6170	18		
			1.63	II				25	E6175	18		
51.8	27800	(3150)	1.06	I	62.5	23100	(2610)	1.06	I	25	D6160	28
			1.30	I				25	D6165	28		
37.7	38300	(4330)	1.06	I	45.5	31700	(3580)	1.06	I	25	D6160	39
			1.30	I				25	D6165	39		
			1.49	II				25	E6170	39		
			1.63	II				25	E6175	39		
31.9	45200	(5110)	1.06	I	38.5	37500	(4240)	1.06	I	25	D6160	46
			1.21	I				25	D6165	46		
			1.47	II				25	E6170	46		
			1.63	II				25	E6175	46		
27.6	52200	(5900)	1.01	I	33.3	43300	(4890)	1.01	I	25	D6160	53
			1.05	I				25	D6165	53		
			1.38	I				25	E6170	53		
			1.47	II				25	E6175	53		
24.4	59200	(6680)	0.93	-	29.4	49000	(5540)	1.02	I	25	D6165	60
			1.06	I				25	E6170	60		
			1.29	I				25	E6175	60		
19.7	73100	(8260)	0.75	-	23.8	60600	(6840)	0.87	-	25	D6165	74
			1.00	I				25	E6170	74		
			1.05	I				25	E6175	74		
16.6	87000	(9830)	0.84	-	20.0	72100	(8140)	0.85	-	25	E6170	88
			0.88	-				25	E6175	88		
14.3	101000	(11400)	0.76	-	17.2	83600	(9450)	0.92	-	25	E6175	102

Cyclo® HBB

Selection
Tables

Notes: [1] Variable Frequency Drive (VFD) notes (see page 3.8 for Constant Torque Speed Ranges):

(-) = For Inverter Operation, starting condition may require ambient temperature of 5° C or higher.

(a) = Both AV and non-AV motors can be used for selection.

Single Reduction Selection Tables: Y1, Y2, Y3, Y4

**30 HP
(22 kW)**

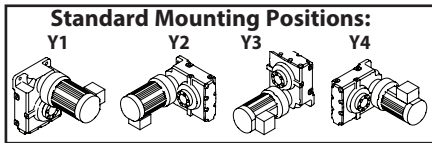

Selection Table Pages:

Single Reduction	3.10-3.38
-Y1,Y2,Y3,Y4	3.10-3.38
-Y5,Y6	3.39-3.61
Double Reduction	3.62-3.79
-Y1,Y2,Y3,Y4,Y5,Y6	3.62-3.79

Dimension Pages:

Single Reduction	3.80-3.85
Double Reduction	3.86-3.91

Frequency	50 Hz	60 Hz
Input Speed	1450 RPM	1750 RPM
Number of Poles	4	

50Hz				60 Hz				Selection					
Output Speed (RPM)	Output Torque		Service Factor		Output Speed (RPM)	Output Torque		Service Factor		Base		VFD ^[1]	
	in-lbs	(N·m)	SF	AGMA Class		in-lbs	(N·m)	SF	AGMA Class	Motor Power Code	Frame Size		Ratio
138	12400 (1400)		0.90	-	167	10300 (1160)		0.90	-	30	D6160	11	
			1.04	I				1.07	I	30	D6165	11	
			1.22	I				1.22	I	30	E6170	11	
			1.34	I				1.34	I	30	E6175	11	
82.9	20700 (2340)		0.92	-	100	17100 (1940)		0.92	-	30	D6160	18	
			1.06	I				1.09	I	30	D6165	18	
			1.25	I				1.25	I	30	E6170	18	
			1.37	I				1.37	I	30	E6175	18	
51.8	33100 (3740)		0.90	-	62.5	27400 (3100)		0.90	-	30	D6160	28	
			1.09	I				1.09	I	30	D6165	28	
37.7	45500 (5140)		0.90	-	45.5	37700 (4260)		0.90	-	30	D6160	39	
			1.09	I				1.09	I	30	D6165	39	
			1.25	I				1.25	I	30	E6170	39	
			1.37	I				1.37	I	30	E6175	39	
31.9	53800 (6080)		0.90	-	38.5	44600 (5040)		0.90	-	30	D6160	46	
			1.02	I				1.03	I	30	D6165	46	
			1.24	I				1.24	I	30	E6170	46	
			1.37	I				1.37	I	30	E6175	46	
27.6	62100 (7010)		0.85	-	33.3	51400 (5810)		0.85	-	30	D6160	53	
			0.88	-				1.03	I	30	D6165	53	
			1.16	I				1.16	I	30	E6170	53	
			1.23	I				1.37	I	30	E6175	53	
24.4	70400 (7950)		0.78	-	29.4	58300 (6590)		0.86	-	30	D6165	60	
			0.89	-				0.89	-	30	E6170	60	
			1.09	I				1.09	I	30	E6175	60	
19.7	86900 (9820)		0.84	-	23.8	72000 (8140)		0.89	-	30	E6170	74	
			0.88	-				1.06	I	30	E6175	74	
16.6	103000 (11700)		0.74	-	20.0	85700 (9690)		0.89	-	30	E6175	88	

Cyclo® HBB

Selection
Tables

Notes: [1] Variable Frequency Drive (VFD) notes (see page 3.8 for Constant Torque Speed Ranges):

(-) = For Inverter Operation, starting condition may require ambient temperature of 5° C or higher.

(a) = Both AV and non-AV motors can be used for selection.

Single Reduction Selection Tables: Y1, Y2, Y3, Y4

**40 HP
(30 kW)**

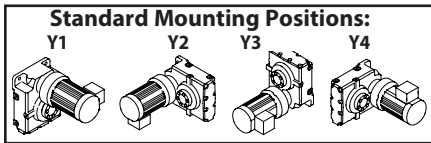

Selection Table Pages:

Single Reduction	
-Y1,Y2,Y3,Y4	3.10-3.38
-Y5,Y6	3.39-3.61
Double Reduction	
-Y1,Y2,Y3,Y4,Y5,Y6	3.62-3.79

Dimension Pages:

Single Reduction	3.80-3.85
Double Reduction	3.86-3.91

Frequency	50 Hz	60 Hz
Input Speed	1450 RPM	1750 RPM
Number of Poles	4	

50Hz					60 Hz					Selection			
Output Speed (RPM)	Output Torque		Service Factor		Output Speed (RPM)	Output Torque		Service Factor		Motor Power Code	Base		VFD ^[1]
	in·lbs	(N·m)	SF	AGMA Class		in·lbs	(N·m)	SF	AGMA Class		Frame Size	Ratio	
138	16900	(1910)	0.90	-	167	14000	(1580)	0.90	-	40	E6170	11	
			0.98	-				40	E6175	11			
82.9	28200	(3190)	0.92	-	100	23400	(2640)	0.92	-	40	E6170	18	
			1.00	I				40	E6175	18			
37.7	62100	(7010)	0.92	-	45.5	51400	(5810)	0.92	-	40	E6170	39	
			1.00	I				40	E6175	39			
31.9	73400	(8290)	0.91	-	38.5	60800	(6870)	0.91	-	40	E6170	46	
			1.00	I				40	E6175	46			
27.6	84700	(9560)	0.85	-	33.3	70100	(7920)	0.85	-	40	E6170	53	
			0.90	-				40	E6175	53			
24.4	95900	(10800)	0.80	-	29.4	79500	(8980)	0.80	-	40	E6175	60	

Cyclo® HBB

Selection
Tables

Notes: [1] Variable Frequency Drive (VFD) notes (see page 3.8 for Constant Torque Speed Ranges):

(-) = For Inverter Operation, starting condition may require ambient temperature of 5° C or higher.

(a) = Both AV and non-AV motors can be used for selection.

Single Reduction Selection Tables: Y5, Y6*

**1/8 HP
(0.1 kW)**

Standard Mounting Positions:

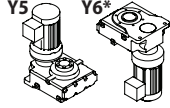

Selection Table Pages:

Single Reduction	
-Y1, Y2, Y3, Y4	3.10-3.38
-Y5, Y6	3.39-3.61
Double Reduction	
-Y1, Y2, Y3, Y4, Y5, Y6	3.62-3.79

Dimension Pages:

Single Reduction	3.80-3.85
Double Reduction	3.86-3.91

Frequency	50 Hz	60 Hz
Input Speed	1450 RPM	1750 RPM
Number of Poles	4	

50Hz					60 Hz					Selection			
Output Speed (RPM)	Output Torque		Service Factor		Output Speed (RPM)	Output Torque		Service Factor		Base			VFD ^[1]
	in-lbs	(N·m)	SF	AGMA Class		in-lbs	(N·m)	SF	AGMA Class	Motor Power Code	Frame Size	Ratio	
7.02	1110	(125)	3.09	III	8.47	920	(104)	3.09	III	01	Z6090	207	(a)
5.84	1340	(151)	2.52	III	7.04	1110	(125)	2.52	III	01	Z6090	249	(a)
			2.78	III				01	Z6095	249	(a)		
4.76	1640	(185)	2.11	III	5.75	1360	(153)	2.11	III	01	Z6090	305	(a)
			2.39	III				01	Z6095	305	(a)		
3.48	2240	(253)	1.25	I	4.20	1850	(210)	1.25	I	01	Z6090	417	(a)
			1.45	II				01	Z6095	417	(a)		

Cyclo® HBB

Selection
Tables

Notes: * Y6 position is not available for ratio 11 and 18.

[1] Variable Frequency Drive (VFD) notes (see page 3.8 for Constant Torque Speed Ranges):

Single Reduction Selection Tables: Y5, Y6*

**1/4 HP
(0.2 kW)**

Standard Mounting Positions:

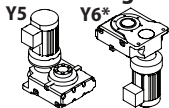

Selection Table Pages:

Single Reduction
-Y1,Y2,Y3,Y4 3.10-3.38
-Y5,Y6 3.39-3.61
Double Reduction
-Y1,Y2,Y3,Y4,Y5,Y6 3.62-3.79

Dimension Pages:

Single Reduction 3.80-3.85
Double Reduction 3.86-3.91

Frequency	50 Hz	60 Hz
Input Speed	1450 RPM	1750 RPM
Number of Poles	4	

50Hz					60 Hz					Selection			
Output Speed (RPM)	Output Torque		Service Factor		Output Speed (RPM)	Output Torque		Service Factor		Motor Power Code	Base		VFD ^[1]
	in·lbs	(N·m)	SF	AGMA Class		in·lbs	(N·m)	SF	AGMA Class		Frame Size	Ratio	
14.3	1090	(123)	3.13	III	17.2	904	(102)	3.13	III	02	Z6090	102	(a)
11.8	1320	(149)	2.97	III	14.3	1090	(123)	3.06	III	02	Z6090	123	(a)
			2.97	III				3.58	III	02	Z6095	123	(a)
9.63	1620	(183)	2.18	III	11.6	1340	(151)	2.18	III	02	Z6090	151	(a)
			2.41	III				2.91	III	02	Z6095	151	(a)
8.12	1920	(217)	1.66	II	9.80	1590	(180)	1.66	II	02	Z6090	179	(a)
			2.04	III				2.11	III	02	Z6095	179	(a)
			2.80	III				2.80	III	02	A6100	179	(a)
7.02	2220	(251)	1.54	II	8.47	1840	(208)	1.54	II	02	Z6090	207	(a)
			1.68	II				1.86	II	02	Z6095	207	(a)
			2.58	III				2.58	III	02	A6100	207	(a)
5.84	2670	(302)	1.26	I	7.04	2210	(250)	1.26	I	02	Z6090	249	(a)
			1.39	I				1.51	II	02	Z6095	249	(a)
			2.18	III				2.18	III	02	A6100	249	(a)
			2.53	III				2.81	III	02	A6105	249	(a)
4.76	3270	(370)	1.06	I	5.75	2710	(306)	1.06	I	02	Z6090	305	(a)
			1.19	I				1.44	II	02	Z6095	305	(a)
			2.17	III				2.17	III	02	A6100	305	(a)
			2.39	III				2.83	III	02	A6105	305	(a)
3.48	4480	(506)	1.05	I	4.20	3710	(419)	1.05	I	02	A6100	417	(a)
			1.43	II				1.43	II	02	A6105	417	(a)

Cyclo® HBB

Selection
Tables

Notes: * Y6 position is not available for ratio 11 and 18.

[1] Variable Frequency Drive (VFD) notes (see page 3.8 for Constant Torque Speed Ranges):

Single Reduction Selection Tables: Y5, Y6*

**1/3 HP
(0.25 kW)**

Standard Mounting Positions:

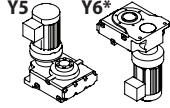

Selection Table Pages:

Single Reduction
-Y1, Y2, Y3, Y4 3.10-3.38
-Y5, Y6 3.39-3.61
Double Reduction
-Y1, Y2, Y3, Y4, Y5, Y6 3.62-3.79

Dimension Pages:

Single Reduction 3.80-3.85
Double Reduction 3.86-3.91

Frequency	50 Hz	60 Hz
Input Speed	1450 RPM	1750 RPM
Number of Poles	4	

50Hz					60 Hz					Selection			
Output Speed (RPM)	Output Torque		Service Factor		Output Speed (RPM)	Output Torque		Service Factor		Motor Power Code	Base		VFD ^[1]
	in·lbs	(N·m)	SF	AGMA Class		in·lbs	(N·m)	SF	AGMA Class		Frame Size	Ratio	
19.7	988	(112)	3.03	III	23.8	818	(92.5)	3.03	III	03	Z6090	74	(a)
16.6	1180	(133)	2.68	III	20.0	974	(110)	2.68	III	03	Z6090	88	(a)
14.3	1360	(154)	2.50	III	17.2	1130	(128)	2.50	III	03	Z6090	102	(a)
			2.86	III				3.13	III		Z6095	102	(a)
11.8	1650	(186)	2.37	III	14.3	1360	(154)	2.45	III	03	Z6090	123	(a)
			2.37	III				2.86	III		Z6095	123	(a)
9.63	2020	(228)	1.74	II	11.6	1680	(189)	1.74	II	03	Z6090	151	(a)
			1.93	II				2.33	III		Z6095	151	(a)
			3.12	III				3.12	III		A6100	151	(a)
8.12	2400	(271)	1.33	I	9.80	1990	(225)	1.33	I	03	Z6090	179	(a)
			1.63	II				1.69	II		Z6095	179	(a)
			2.24	III				2.24	III		A6100	179	(a)
			3.10	III				3.10	III		A6105	179	(a)
7.02	2770	(313)	1.24	I	8.47	2300	(260)	1.24	I	03	Z6090	207	(a)
			1.34	I				1.49	II		Z6095	207	(a)
			2.06	III				2.06	III		A6100	207	(a)
			2.72	III				2.83	III		A6105	207	(a)
5.84	3340	(377)	1.01	I	7.04	2770	(313)	1.01	I	03	Z6090	249	(a)
			1.11	I				1.21	I		Z6095	249	(a)
			1.74	II				1.74	II		A6100	249	(a)
			2.02	III				2.24	III		A6105	249	(a)
4.76	4090	(462)	0.85	-	5.75	3390	(383)	0.85	-	03	Z6090	305	(a)
			0.95	-				1.15	I		Z6095	305	(a)
			1.73	II				1.73	II		A6100	305	(a)
			1.91	II				2.26	III		A6105	305	(a)
3.48	5600	(632)	0.84	-	4.20	4640	(524)	0.84	-	03	A6100	417	(a)
			1.14	I				1.14	I		A6105	417	(a)

Cyclo® HBB

Selection
Tables

Notes: * Y6 position is not available for ratio 11 and 18.

[1] Variable Frequency Drive (VFD) notes (see page 3.8 for Constant Torque Speed Ranges):

Single Reduction Selection Tables: Y5, Y6*

**1/2 HP
(0.4 kW)**

Standard Mounting Positions:

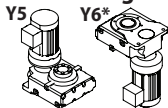

Selection Table Pages:

Single Reduction
-Y1,Y2,Y3,Y4 3.10-3.38
-Y5,Y6 3.39-3.61
Double Reduction
-Y1,Y2,Y3,Y4,Y5,Y6 3.62-3.79

Dimension Pages:

Single Reduction 3.80-3.85
Double Reduction 3.86-3.91

Frequency	50 Hz	60 Hz
Input Speed	1450 RPM	1750 RPM
Number of Poles	4	

50Hz					60 Hz					Selection			
Output Speed (RPM)	Output Torque		Service Factor		Output Speed (RPM)	Output Torque		Service Factor		Base			VFD ^[1]
	in-lbs	(N·m)	SF	AGMA Class		in-lbs	(N·m)	SF	AGMA Class	Motor Power Code	Frame Size	Ratio	
69.0	451	(51.0)	2.87	III	83.3	374	(42.3)	2.87	III	05	Z6090	21	(a)
51.8	602	(68.0)	2.87	III	62.5	499	(56.4)	2.87	III	05	Z6090	28	(a)
37.7	828	(93.5)	2.87	III	45.5	686	(77.5)	2.87	III	05	Z6090	39	(a)
31.9	978	(111)	2.87	III	38.5	810	(91.6)	2.87	III	05	Z6090	46	(a)
27.6	1130	(128)	2.87	III	33.3	935	(106)	2.87	III	05	Z6090	53	(a)
24.4	1280	(145)	2.87	III	29.4	1060	(120)	2.87	III	05	Z6090	60	(a)
			3.05	III				05	Z6095	60	(a)		
19.7	1580	(179)	1.89	II	23.8	1310	(148)	1.89	II	05	Z6090	74	(a)
			2.47	III				05	Z6095	74	(a)		
16.6	1880	(213)	1.68	II	20.0	1560	(176)	1.68	II	05	Z6090	88	(a)
			2.08	III				05	Z6095	88	(a)		
			3.17	III				05	A6100	88	(a)		
14.3	2180	(247)	1.56	II	17.2	1810	(204)	1.56	II	05	Z6090	102	(a)
			1.79	II				05	Z6095	102	(a)		
			3.03	III				05	A6100	102	(a)		
11.8	2630	(298)	1.48	II	14.3	2180	(247)	1.53	II	05	Z6090	123	(a)
			1.48	II				05	Z6095	123	(a)		
			2.44	III				05	A6100	123	(a)		
			2.97	III				05	A6105	123	(a)		
9.63	3240	(366)	1.09	I	11.6	2680	(303)	1.09	I	05	Z6090	151	(a)
			1.21	I				05	Z6095	151	(a)		
			1.95	II				05	A6100	151	(a)		
			2.42	III				05	A6105	151	(a)		
8.12	3840	(434)	0.83	-	9.80	3180	(359)	0.83	-	05	Z6090	179	(a)
			1.02	I				05	Z6095	179	(a)		
			1.40	II				05	A6100	179	(a)		
			1.94	II				05	A6105	179	(a)		
7.02	4440	(502)	0.84	-	8.47	3680	(416)	0.93	-	05	Z6095	207	(a)
			1.29	I				05	A6100	207	(a)		
			1.70	II				05	A6105	207	(a)		
5.84	5340	(604)	1.09	I	7.04	4430	(500)	1.09	I	05	A6100	249	(a)
			1.26	I				05	A6105	249	(a)		
			2.39	III				05	B6120	249	(a)		
			2.84	III				05	B6125	249	(a)		
4.76	6550	(740)	1.08	I	5.75	5420	(613)	1.08	I	05	A6100	305	(a)
			1.20	I				05	A6105	305	(a)		
			2.36	III				05	B6120	305	(a)		
			2.39	III				05	B6125	305	(a)		

Notes: * Y6 position is not available for ratio 11 and 18.

[1] Variable Frequency Drive (VFD) notes (see page 3.8 for Constant Torque Speed Ranges):

Single Reduction Selection Tables: Y5, Y6*

**3/4 HP
(0.55 kW)**

Standard Mounting Positions:

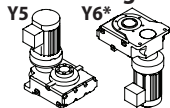

Selection Table Pages:

Single Reduction
-Y1, Y2, Y3, Y4 3.10-3.38
-Y5, Y6 3.39-3.61
Double Reduction
-Y1, Y2, Y3, Y4, Y5, Y6 3.62-3.79

Dimension Pages:

Single Reduction 3.80-3.85
Double Reduction 3.86-3.91

Frequency	50 Hz	60 Hz
Input Speed	1450 RPM	1750 RPM
Number of Poles	4	

50Hz					60 Hz					Selection			
Output Speed (RPM)	Output Torque		Service Factor		Output Speed (RPM)	Output Torque		Service Factor		Base			VFD ^[1]
	in-lbs	(N·m)	SF	AGMA Class		in-lbs	(N·m)	SF	AGMA Class	Motor Power Code	Frame Size	Ratio	
69.0	621	(70.1)	2.08	III	83.3	514	(58.1)	2.08	III	08	Z6090	21	(a)
			2.75	III				08	Z6095	21	(a)		
51.8	828	(93.5)	2.08	III	62.5	686	(77.5)	2.08	III	08	Z6090	28	(a)
			2.75	III				08	Z6095	28	(a)		
37.7	1140	(129)	2.08	III	45.5	943	(107)	2.08	III	08	Z6090	39	(a)
			2.75	III				08	Z6095	39	(a)		
31.9	1340	(152)	2.08	III	38.5	1110	(126)	2.08	III	08	Z6090	46	(a)
			2.75	III				08	Z6095	46	(a)		
27.6	1550	(175)	2.08	III	33.3	1290	(145)	2.08	III	08	Z6090	53	(a)
			2.52	III				08	Z6095	53	(a)		
24.4	1760	(199)	2.08	III	29.4	1460	(165)	2.08	III	08	Z6090	60	(a)
			2.22	III				08	Z6095	60	(a)		
19.7	2170	(245)	1.38	I	23.8	1800	(203)	1.38	I	08	Z6090	74	(a)
			1.80	II				08	Z6095	74	(a)		
16.6	2590	(292)	1.22	I	20.0	2140	(242)	1.22	I	08	Z6090	88	(a)
			1.51	II				08	Z6095	88	(a)		
			2.31	III				08	A6100	88	(a)		
			3.02	III				08	A6105	88	(a)		
14.3	3000	(339)	1.14	I	17.2	2490	(281)	1.14	I	08	Z6090	102	(a)
			1.30	I				08	Z6095	102	(a)		
			2.20	III				08	A6100	102	(a)		
			2.61	III				08	A6105	102	(a)		
11.8	3620	(409)	1.08	I	14.3	3000	(339)	1.11	I	08	Z6090	123	(a)
			1.08	I				08	Z6095	123	(a)		
			1.77	II				08	A6100	123	(a)		
			2.16	III				08	A6105	123	(a)		
9.63	4450	(503)	0.88	-	11.6	3690	(416)	1.06	I	08	Z6095	151	(a)
			1.42	II				08	A6100	151	(a)		
			1.76	II				08	A6105	151	(a)		
8.12	5280	(596)	1.02	I	9.80	4370	(494)	1.02	I	08	A6100	179	(a)
			1.41	II				08	A6105	179	(a)		
			2.96	III				08	B6120	179	(a)		
			2.97	III				08	B6125	179	(a)		
7.02	6100	(690)	0.94	-	8.47	5060	(571)	0.94	-	08	A6100	207	(a)
			1.24	I				08	A6105	207	(a)		
			2.36	III				08	B6120	207	(a)		
			2.57	III				08	B6125	207	(a)		

Notes: * Y6 position is not available for ratio 11 and 18.

[1] Variable Frequency Drive (VFD) notes (see page 3.8 for Constant Torque Speed Ranges):

Cyclo® HBB

Selection
Tables

Single Reduction Selection Tables: Y5, Y6*

**3/4 HP
(0.55 kW)**

Standard Mounting Positions:

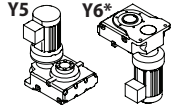

Selection Table Pages:

Single Reduction	
-Y1,Y2,Y3,Y4	3.10-3.38
-Y5,Y6	3.39-3.61
Double Reduction	
-Y1,Y2,Y3,Y4,Y5,Y6	3.62-3.79

Dimension Pages:

Single Reduction	3.80-3.85
Double Reduction	3.86-3.91

Frequency	50 Hz	60 Hz
Input Speed	1450 RPM	1750 RPM
Number of Poles	4	

50Hz				60 Hz				Selection					
Output Speed (RPM)	Output Torque		Service Factor		Output Speed (RPM)	Output Torque		Service Factor		Base			VFD ^[1]
	in-lbs	(N·m)	SF	AGMA Class		in-lbs	(N·m)	SF	AGMA Class	Motor Power Code	Frame Size	Ratio	
5.84	7350	(830)	0.92	-	7.04	6090	(688)	1.02	I	08	A6105	249	(a)
			1.74	II				08	B6120	249	(a)		
			2.07	III				08	B6125	249	(a)		
			2.75	III				08	C6145	249	(a)		
4.76	9000	(1020)	0.87	-	5.75	7460	(843)	1.03	I	08	A6105	305	(a)
			1.72	II				08	B6120	305	(a)		
			1.74	II				08	B6125	305	(a)		
			2.75	III				08	C6145	305	(a)		

Cyclo® HBB

Selection
Tables

Notes: * Y6 position is not available for ratio 11 and 18.

[1] Variable Frequency Drive (VFD) notes (see page 3.8 for Constant Torque Speed Ranges):

Single Reduction Selection Tables: Y5, Y6*

**1 HP
(0.75 kW)**

Standard Mounting Positions:

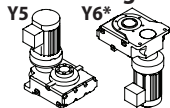

Selection Table Pages:

Single Reduction
-Y1, Y2, Y3, Y4 3.10-3.38
-Y5, Y6 3.39-3.61
Double Reduction
-Y1, Y2, Y3, Y4, Y5, Y6 3.62-3.79

Dimension Pages:

Single Reduction 3.80-3.85
Double Reduction 3.86-3.91

Frequency	50 Hz	60 Hz
Input Speed	1450 RPM	1750 RPM
Number of Poles	4	

50Hz					60 Hz					Selection			
Output Speed (RPM)	Output Torque		Service Factor		Output Speed (RPM)	Output Torque		Service Factor		Base			VFD ^[1]
	in-lbs	(N·m)	SF	AGMA Class		in-lbs	(N·m)	SF	AGMA Class	Motor Power Code	Frame Size	Ratio	
138	423	(47.8)	3.13	III	167	351	(39.6)	3.13	III	1	A6100	11*	
69.0	847	(95.6)	1.53	II	83.3	701	(79.2)	1.53	II	1	Z6090	21	
			2.02	III				2.02	III	1	Z6095	21	
			3.13	III				3.13	III	1	A6100	21	
51.8	1130	(128)	1.53	II	62.5	935	(106)	1.53	II	1	Z6090	28	
			2.02	III				2.02	III	1	Z6095	28	
			3.13	III				3.13	III	1	A6100	28	
37.7	1550	(175)	1.53	II	45.5	1290	(145)	1.53	II	1	Z6090	39	
			2.02	III				2.02	III	1	Z6095	39	
			3.13	III				3.13	III	1	A6100	39	
31.9	1830	(207)	1.53	II	38.5	1520	(172)	1.53	II	1	Z6090	46	
			2.02	III				2.02	III	1	Z6095	46	
			3.13	III				3.13	III	1	A6100	46	
27.6	2120	(239)	1.53	II	33.3	1750	(198)	1.53	II	1	Z6090	53	
			1.85	II				2.02	III	1	Z6095	53	
			3.13	III				3.13	III	1	A6100	53	
24.4	2400	(271)	1.53	II	29.4	1990	(225)	1.53	II	1	Z6090	60	
			1.63	II				1.97	II	1	Z6095	60	
			2.65	III				2.65	III	1	A6100	60	
19.7	2960	(335)	1.01	I	23.8	2450	(277)	1.01	I	1	Z6090	74	
			1.32	I				1.59	II	1	Z6095	74	
			2.53	III				2.57	III	1	A6100	74	
			2.64	III				3.11	III	1	A6105	74	
16.6	3530	(399)	0.89	-	20.0	2920	(330)	0.89	-	1	Z6090	88	
			1.11	I				1.16	I	1	Z6095	88	
			1.69	II				1.69	II	1	A6100	88	
			2.22	III				2.23	III	1	A6105	88	
14.3	4090	(462)	0.83	-	17.2	3390	(383)	0.83	-	1	Z6090	102	
			0.95	-				1.04	I	1	Z6095	102	
			1.61	II				1.61	II	1	A6100	102	
			1.91	II				2.12	III	1	A6105	102	
11.8	4940	(558)	0.79	-	14.3	4090	(462)	0.82	-	1	Z6090	123	
			0.79	-				0.95	-	1	Z6095	123	
			1.30	I				1.30	I	1	A6100	123	
			1.58	II				1.60	II	1	A6105	123	
			3.16	III				3.32	III	1	B6120	123	
			3.17	III				3.83	III	1	B6125	123	

Notes: * Y6 position is not available for ratio 11 and 18.

[1] Variable Frequency Drive (VFD) notes (see page 3.8 for Constant Torque Speed Ranges):

Single Reduction Selection Tables: Y5, Y6*

**1 HP
(0.75 kW)**

Standard Mounting Positions:

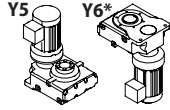

Selection Table Pages:

Single Reduction	
-Y1,Y2,Y3,Y4	3.10-3.38
-Y5,Y6	3.39-3.61
Double Reduction	
-Y1,Y2,Y3,Y4,Y5,Y6	3.62-3.79

Dimension Pages:

Single Reduction	3.80-3.85
Double Reduction	3.86-3.91

Frequency	50 Hz	60 Hz
Input Speed	1450 RPM	1750 RPM
Number of Poles	4	

50Hz				60 Hz				Selection					
Output Speed (RPM)	Output Torque		Service Factor		Output Speed (RPM)	Output Torque		Service Factor		Base		VFD ^[1]	
	in-lbs	(N·m)	SF	AGMA Class		in-lbs	(N·m)	SF	AGMA Class	Motor Power Code	Frame Size		Ratio
9.63	6070	(685)	1.04	I	11.6	5030	(568)	1.04	I	1	A6100	151	
			1.29	I				1	A6105	151			
			2.55	III				1	B6120	151			
			2.58	III				1	B6125	151			
8.12	7200	(813)	1.03	I	9.80	5960	(674)	1.03	I	1	A6105	179	
			2.17	III				1	B6120	179			
			2.18	III				1	B6125	179			
			2.96	III				1	C6145	179			
7.02	8320	(940)	0.91	-	8.47	6900	(779)	0.94	-	1	A6105	207	
			1.73	II				1	B6120	207			
			1.88	II				1	B6125	207			
			2.96	III				1	C6145	207			
5.84	10000	(1130)	1.28	I	7.04	8300	(938)	1.28	I	1	B6120	249	
			1.52	II				1	B6125	249			
			2.02	III				1	C6145	249			
			2.96	III				1	D6165	249			
4.76	12300	(1390)	1.26	I	5.75	10200	(1150)	1.26	I	1	B6120	305	
			1.28	I				1	B6125	305			
			2.02	III				1	C6145	305			
			2.96	III				1	D6165	305			

Cyclo® HBB

Selection
Tables

Notes: * Y6 position is not available for ratio 11 and 18.

[1] Variable Frequency Drive (VFD) notes (see page 3.8 for Constant Torque Speed Ranges):

All 1HP+ motors require EP suffix in model number and can be used with a VFD, unless noted.

Single Reduction Selection Tables: Y5, Y6*

**1.5 HP
(1.1 kW)**

Standard Mounting Positions:

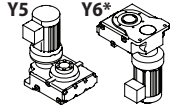

Selection Table Pages:

Single Reduction
-Y1,Y2,Y3,Y4 3.10-3.38
-Y5,Y6 3.39-3.61
Double Reduction
-Y1,Y2,Y3,Y4,Y5,Y6 3.62-3.79

Dimension Pages:

Single Reduction 3.80-3.85
Double Reduction 3.86-3.91

Frequency	50 Hz	60 Hz
Input Speed	1450 RPM	1750 RPM
Number of Poles	4	

50Hz					60 Hz					Selection			
Output Speed (RPM)	Output Torque		Service Factor		Output Speed (RPM)	Output Torque		Service Factor		Base			VFD ^[1]
	in-lbs	(N·m)	SF	AGMA Class		in-lbs	(N·m)	SF	AGMA Class	Motor Power Code	Frame Size	Ratio	
138	621	(70.1)	2.14	III	167	514	(58.1)	2.14	III	1H	A6100	11*	
			2.89	III				2.89	III	1H	A6105	11*	
82.9	1030	(117)	2.23	III	100	857	(96.9)	2.23	III	1H	A6100	18*	
			3.01	III				3.01	III	1H	A6105	18*	
69.0	1240	(140)	1.04	I	83.3	1030	(116)	1.04	I	1H	Z6090	21	
			1.38	I				1.38	I	1H	Z6095	21	
			2.13	III				2.13	III	1H	A6100	21	
			2.89	III				2.89	III	1H	A6105	21	
51.8	1660	(187)	1.04	I	62.5	1370	(155)	1.04	I	1H	Z6090	28	
			1.38	I				1.38	I	1H	Z6095	28	
			2.13	III				2.13	III	1H	A6100	28	
			2.89	III				2.89	III	1H	A6105	28	
37.7	2280	(257)	1.04	I	45.5	1890	(213)	1.04	I	1H	Z6090	39	
			1.38	I				1.38	I	1H	Z6095	39	
			2.13	III				2.13	III	1H	A6100	39	
			2.89	III				2.89	III	1H	A6105	39	
31.9	2690	(304)	1.04	I	38.5	2230	(252)	1.04	I	1H	Z6090	46	
			1.38	I				1.38	I	1H	Z6095	46	
			2.13	III				2.13	III	1H	A6100	46	
			2.89	III				2.89	III	1H	A6105	46	
27.6	3100	(351)	1.04	I	33.3	2570	(291)	1.04	I	1H	Z6090	53	
			1.26	I				1.38	I	1H	Z6095	53	
			2.13	III				2.13	III	1H	A6100	53	
			2.52	III				2.89	III	1H	A6105	53	
24.4	3520	(397)	1.04	I	29.4	2910	(329)	1.04	I	1H	Z6090	60	
			1.11	I				1.34	I	1H	Z6095	60	
			1.81	II				1.81	II	1H	A6100	60	
			2.22	III				2.23	III	1H	A6105	60	
19.7	4350	(491)	0.90	-	23.8	3600	(407)	1.08	I	1H	Z6095	74	
			1.73	II				1.75	II	1H	A6100	74	
			1.80	II				2.12	III	1H	A6105	74	
16.6	5170	(584)	1.15	I	20.0	4290	(484)	1.15	I	1H	A6100	88	
			1.51	II				1.52	II	1H	A6105	88	
			2.81	III				2.81	III	1H	B6120	88	
			3.03	III				3.60	III	1H	B6125	88	

Cyclo® HBB

Selection
Tables

Notes: * Y6 position is not available for ratio 11 and 18.

[1] Variable Frequency Drive (VFD) notes (see page 3.8 for Constant Torque Speed Ranges):

All 1HP+ motors require EP suffix in model number and can be used with a VFD, unless noted.

Single Reduction Selection Tables: Y5, Y6*

1.5 HP
(1.1 kW)

Standard Mounting Positions:

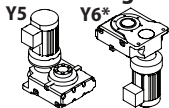

Selection Table Pages:

Single Reduction
-Y1,Y2,Y3,Y4 3.10-3.38
-Y5,Y6 3.39-3.61
Double Reduction
-Y1,Y2,Y3,Y4,Y5,Y6 3.62-3.79

Dimension Pages:

Single Reduction 3.80-3.85
Double Reduction 3.86-3.91

Frequency	50 Hz	60 Hz
Input Speed	1450 RPM	1750 RPM
Number of Poles	4	

50Hz				60 Hz				Selection					
Output Speed (RPM)	Output Torque		Service Factor		Output Speed (RPM)	Output Torque		Service Factor		Base		VFD ^[1]	
	in-lbs	(N·m)	SF	AGMA Class		in-lbs	(N·m)	SF	AGMA Class	Motor Power Code	Frame Size		Ratio
14.3	6000	(678)	1.10	I	17.2	4970	(562)	1.10	I	1H	A6100	102	
			1.30	I				1H	A6105	102			
			2.61	III				1H	B6120	102			
			2.61	III				1H	B6125	102			
11.8	7240	(818)	0.89	-	14.3	6000	(678)	0.89	-	1H	A6100	123	
			1.08	I				1H	A6105	123			
			2.15	III				1H	B6120	123			
			2.16	III				1H	B6125	123			
9.63	8900	(1010)	0.88	-	11.6	7370	(833)	0.98	-	1H	A6105	151	
			1.74	II				1H	B6120	151			
			1.76	II				1H	B6125	151			
8.12	10600	(1190)	1.48	II	9.80	8740	(988)	1.56	II	1H	B6120	179	
			1.48	II				1H	B6125	179			
			2.02	III				1H	C6145	179			
7.02	12200	(1380)	1.18	I	8.47	10100	(1140)	1.18	I	1H	B6120	207	
			1.28	I				1H	B6125	207			
			2.02	III				1H	C6145	207			
5.84	14700	(1660)	0.87	-	7.04	12200	(1380)	0.87	-	1H	B6120	249	
			1.03	I				1H	B6125	249			
			1.38	I				1H	C6145	249			
			2.02	III				1H	D6165	249			
4.76	18000	(2030)	0.86	-	5.75	14900	(1690)	0.86	-	1H	B6120	305	
			0.87	-				1H	B6125	305			
			1.38	I				1H	C6145	305			
			2.02	III				1H	D6165	305			

Cyclo® HBB

Selection
Tables

Notes: * Y6 position is not available for ratio 11 and 18.

[1] Variable Frequency Drive (VFD) notes (see page 3.8 for Constant Torque Speed Ranges):

All 1HP+ motors require EP suffix in model number and can be used with a VFD, unless noted.

Single Reduction Selection Tables: Y5, Y6*

**2 HP
(1.5 kW)**

Standard Mounting Positions:

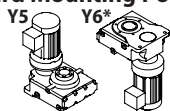

Selection Table Pages:

Single Reduction
-Y1, Y2, Y3, Y4 3.10-3.38
-Y5, Y6 3.39-3.61
Double Reduction
-Y1, Y2, Y3, Y4, Y5, Y6 3.62-3.79

Dimension Pages:

Single Reduction 3.80-3.85
Double Reduction 3.86-3.91

Frequency	50 Hz	60 Hz
Input Speed	1450 RPM	1750 RPM
Number of Poles	4	

50Hz					60 Hz					Selection			
Output Speed (RPM)	Output Torque		Service Factor		Output Speed (RPM)	Output Torque		Service Factor		Motor Power Code	Base		VFD ^[1]
	in·lbs	(N·m)	SF	AGMA Class		in·lbs	(N·m)	SF	AGMA Class		Frame Size	Ratio	
138	847	(95.6)	1.57	II	167	701	(79.2)	1.57	II	2	A6100	11*	
			2.12	III				2.12	III		A6105	11*	
82.9	1410	(159)	1.63	II	100	1170	(132)	1.63	II	2	A6100	18*	
			2.21	III				2.21	III		A6105	18*	
69.0	1690	(191)	1.01	I	83.3	1400	(158)	1.01	I	2	Z6095	21	
			1.56	II				1.56	II		A6100	21	
			2.12	III				2.12	III		A6105	21	
51.8	2260	(255)	1.01	I	62.5	1870	(211)	1.01	I	2	Z6095	28	
			1.56	II				1.56	II		A6100	28	
			2.12	III				2.12	III		A6105	28	
37.7	3100	(351)	1.01	I	45.5	2570	(291)	1.01	I	2	Z6095	39	
			1.56	II				1.56	II		A6100	39	
			2.12	III				2.12	III		A6105	39	
31.9	3670	(414)	1.01	I	38.5	3040	(343)	1.01	I	2	Z6095	46	
			1.56	II				1.56	II		A6100	46	
			2.12	III				2.12	III		A6105	46	
27.6	4230	(478)	0.92	-	33.3	3510	(396)	1.01	I	2	Z6095	53	
			1.56	II				1.56	II		A6100	53	
			1.85	II				2.12	III		A6105	53	
24.4	4800	(542)	0.81	-	29.4	3970	(449)	0.98	-	2	Z6095	60	
			1.32	I				1.32	I		A6100	60	
			1.63	II				1.64	II		A6105	60	
19.7	5930	(669)	0.66	-	23.8	4910	(555)	0.80	-	2	Z6095	74	
			1.27	I				1.28	I		A6100	74	
			1.32	I				1.56	II		A6105	74	
			2.64	III				2.64	III		B6120	74	
			2.64	III				3.19	III		B6125	74	
16.6	7050	(797)	0.85	-	20.0	5840	(660)	0.85	-	2	A6100	88	
			1.11	I				1.11	I		A6105	88	
			2.06	III				2.06	III		B6120	88	
			2.22	III				2.64	III		B6125	88	
14.3	8180	(925)	0.81	-	17.2	6780	(766)	0.81	-	2	A6100	102	
			0.96	-				1.06	I		A6105	102	
			1.91	II				1.99	II		B6120	102	
			1.91	II				2.31	III		B6125	102	
			2.49	III				2.49	III		C6145	102	

Notes: * Y6 position is not available for ratio 11 and 18.

[1] Variable Frequency Drive (VFD) notes (see page 3.8 for Constant Torque Speed Ranges):

All 1HP+ motors require EP suffix in model number and can be used with a VFD, unless noted.

Single Reduction Selection Tables: Y5, Y6*

**2 HP
(1.5 kW)**

Standard Mounting Positions:

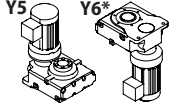

Selection Table Pages:

Single Reduction	
-Y1,Y2,Y3,Y4	3.10-3.38
-Y5,Y6	3.39-3.61
Double Reduction	
-Y1,Y2,Y3,Y4,Y5,Y6	3.62-3.79

Dimension Pages:

Single Reduction	3.80-3.85
Double Reduction	3.86-3.91

Frequency	50 Hz	60 Hz
Input Speed	1450 RPM	1750 RPM
Number of Poles	4	

50Hz				60 Hz				Selection					
Output Speed (RPM)	Output Torque		Service Factor		Output Speed (RPM)	Output Torque		Service Factor		Base		VFD ^[1]	
	in-lbs	(N·m)	SF	AGMA Class		in-lbs	(N·m)	SF	AGMA Class	Motor Power Code	Frame Size		Ratio
11.8	9880	(1120)	0.79	-	14.3	8180	(925)	0.80	-	2	A6105	123	
			1.58	II				2	B6120	123			
			1.59	II				2	B6125	123			
			2.49	III				2	C6145	123			
9.63	12100	(1370)	1.27	I	11.6	10100	(1140)	1.27	I	2	B6120	151	
			1.29	I				2	B6125	151			
			2.49	III				2	D6165	151			
8.12	14400	(1630)	1.09	I	9.80	11900	(1350)	1.14	I	2	B6120	179	
			1.09	I				2	B6125	179			
			1.48	II				2	C6145	179			
			2.49	III				2	D6165	179			
7.02	16600	(1880)	0.87	-	8.47	13800	(1560)	0.87	-	2	B6120	207	
			0.94	-				2	B6125	207			
			1.48	II				2	C6145	207			
			2.49	III				2	D6165	207			
5.84	20000	(2260)	0.76	-	7.04	16600	(1880)	0.80	-	2	B6125	249	
			1.01	I				2	C6145	249			
			1.48	II				2	D6165	249			
4.76	24500	(2770)	1.01	I	5.75	20300	(2300)	1.01	I	2	C6145	305	
			1.48	II				2	D6165	305			

Cyclo® HBB

Selection
Tables

Notes: * Y6 position is not available for ratio 11 and 18.

[1] Variable Frequency Drive (VFD) notes (see page 3.8 for Constant Torque Speed Ranges):

All 1HP+ motors require EP suffix in model number and can be used with a VFD, unless noted.

Single Reduction Selection Tables: Y5, Y6*

**3 HP
(2.2 kW)**

Standard Mounting Positions:

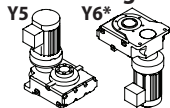

Selection Table Pages:

Single Reduction
-Y1,Y2,Y3,Y4 3.10-3.38
-Y5,Y6 3.39-3.61
Double Reduction
-Y1,Y2,Y3,Y4,Y5,Y6 3.62-3.79

Dimension Pages:

Single Reduction 3.80-3.85
Double Reduction 3.86-3.91

Frequency	50 Hz	60 Hz
Input Speed	1450 RPM	1750 RPM
Number of Poles	4	

50Hz				60 Hz				Selection					
Output Speed (RPM)	Output Torque		Service Factor		Output Speed (RPM)	Output Torque		Service Factor		Base		VFD ^[1]	
	in-lbs	(N·m)	SF	AGMA Class		in-lbs	(N·m)	SF	AGMA Class	Motor Power Code	Frame Size		Ratio
138	1240	(140)	1.07	I	167	1030	(116)	1.07	I	3	A6100	11*	
			1.45	II				1.45	II	3	A6105	11*	
			2.30	III				2.30	III	3	B6120	11*	
			2.82	III				2.64	III	3	B6125	11*	
82.9	2070	(234)	1.11	I	100	1710	(194)	1.11	I	3	A6100	18*	
			1.51	II				1.51	II	3	A6105	18*	
			2.35	III				2.35	III	3	B6120	18*	
			2.88	III				2.70	III	3	B6125	18*	
69.0	2480	(281)	1.07	I	83.3	2060	(232)	1.07	I	3	A6100	21	
			1.45	II				1.45	II	3	A6105	21	
			2.30	III				2.30	III	3	B6120	21	
			3.16	III				2.64	III	3	B6125	21	
51.8	3310	(374)	1.07	I	62.5	2740	(310)	1.07	I	3	A6100	28	
			1.45	II				1.45	II	3	A6105	28	
			2.30	III				2.30	III	3	B6120	28	
			3.16	III				3.16	III	3	B6125	28	
37.7	4550	(514)	1.07	I	45.5	3770	(426)	1.07	I	3	A6100	39	
			1.45	II				1.45	II	3	A6105	39	
			2.30	III				2.30	III	3	B6120	39	
			2.69	III				2.69	III	3	B6125	39	
31.9	5380	(608)	1.07	I	38.5	4460	(504)	1.07	I	3	A6100	46	
			1.45	II				1.45	II	3	A6105	46	
			2.30	III				2.30	III	3	B6120	46	
			2.69	III				2.69	III	3	B6125	46	
27.6	6210	(701)	1.07	I	33.3	5140	(581)	1.07	I	3	A6100	53	
			1.26	I				1.45	II	3	A6105	53	
			2.30	III				2.30	III	3	B6120	53	
			2.52	III				2.69	III	3	B6125	53	
24.4	7040	(795)	0.90	-	29.4	5830	(659)	0.90	-	3	A6100	60	
			1.11	I				1.12	I	3	A6105	60	
			2.22	III				2.30	III	3	B6120	60	
			2.23	III				2.57	III	3	B6125	60	
19.7	8690	(982)	0.86	-	23.8	7200	(814)	0.88	-	3	A6100	74	
			0.90	-				1.06	I	3	A6105	74	
			1.80	II				1.80	II	3	B6120	74	
			1.80	II				2.18	III	3	B6125	74	
			2.53	III				2.53	III	3	C6145	74	

Notes: * Y6 position is not available for ratio 11 and 18.

[1] Variable Frequency Drive (VFD) notes (see page 3.8 for Constant Torque Speed Ranges):

All 1HP+ motors require EP suffix in model number and can be used with a VFD, unless noted.

Single Reduction Selection Tables: Y5, Y6*

**3 HP
(2.2 kW)**

Standard Mounting Positions:

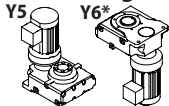

Selection Table Pages:

Single Reduction
-Y1,Y2,Y3,Y4 3.10-3.38
-Y5,Y6 3.39-3.61
Double Reduction
-Y1,Y2,Y3,Y4,Y5,Y6 3.62-3.79

Dimension Pages:

Single Reduction 3.80-3.85
Double Reduction 3.86-3.91

Frequency	50 Hz	60 Hz
Input Speed	1450 RPM	1750 RPM
Number of Poles	4	

50Hz					60 Hz					Selection			VFD ^[1]
Output Speed (RPM)	Output Torque		Service Factor		Output Speed (RPM)	Output Torque		Service Factor		Base			
	in-lbs	(N·m)	SF	AGMA Class		in-lbs	(N·m)	SF	AGMA Class	Motor Power Code	Frame Size	Ratio	
16.6	10300	(1170)	1.40	II	20.0	8570	(969)	1.40	II	3	B6120	88	
			1.51	II				3	B6125	88			
			2.53	III				3	C6145	88			
14.3	12000	(1360)	1.30	I	17.2	9940	(1120)	1.36	I	3	B6120	102	
			1.31	I				3	B6125	102			
			1.70	II				3	C6145	102			
11.8	14500	(1640)	1.08	I	14.3	12000	(1360)	1.13	I	3	B6120	123	
			1.08	I				3	B6125	123			
			1.70	II				3	C6145	123			
9.63	17800	(2010)	0.87	-	11.6	14700	(1670)	0.87	-	3	B6120	151	
			0.88	-				3	B6125	151			
			1.70	II				3	D6165	151			
8.12	21100	(2380)	0.74	-	9.80	17500	(1980)	0.90	-	3	B6125	179	
			1.01	I				3	C6145	179			
			1.70	II				3	D6165	179			
			2.53	III				3	E6175	179			
7.02	24400	(2760)	1.01	I	8.47	20200	(2290)	1.01	I	3	C6145	207	
			1.70	II				3	D6165	207			
			2.53	III				3	E6175	207			
5.84	29400	(3320)	1.01	I	7.04	24300	(2750)	1.01	I	3	D6165	249	
			1.70	II				3	E6175	249			
4.76	36000	(4070)	1.01	I	5.75	29800	(3370)	1.01	I	3	D6165	305	
			1.70	II				3	E6175	305			

Cyclo® HBB

Selection
Tables

Notes: * Y6 position is not available for ratio 11 and 18.

[1] Variable Frequency Drive (VFD) notes (see page 3.8 for Constant Torque Speed Ranges):

All 1HP+ motors require EP suffix in model number and can be used with a VFD, unless noted.

Single Reduction Selection Tables: Y5, Y6*

**5 HP
(3.7 kW)**

Standard Mounting Positions:

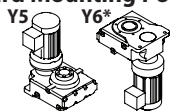

Selection Table Pages:

Single Reduction
-Y1,Y2,Y3,Y4 3.10-3.38
-Y5,Y6 3.39-3.61
Double Reduction
-Y1,Y2,Y3,Y4,Y5,Y6 3.62-3.79

Dimension Pages:

Single Reduction 3.80-3.85
Double Reduction 3.86-3.91

Frequency	50 Hz	60 Hz
Input Speed	1450 RPM	1750 RPM
Number of Poles	4	

50Hz				60 Hz				Selection					
Output Speed (RPM)	Output Torque		Service Factor		Output Speed (RPM)	Output Torque		Service Factor		Base		VFD ^[1]	
	in-lbs	(N·m)	SF	AGMA Class		in-lbs	(N·m)	SF	AGMA Class	Motor Power Code	Frame Size		Ratio
138	2090	(236)	1.37	I	167	1730	(195)	1.37	I	5	B6120	11*	
			1.68	II				5	B6125	11*			
			2.47	III				5	C6140	11*			
			2.87	III				5	C6145	11*			
82.9	3480	(393)	1.40	II	100	2880	(326)	1.40	II	5	B6120	18*	
			1.71	II				5	B6125	18*			
			2.56	III				5	C6140	18*			
			2.97	III				5	C6145	18*			
69.0	4180	(472)	1.37	I	83.3	3460	(391)	1.37	I	5	B6120	21	
			1.88	II				5	B6125	21			
			3.00	III				5	C6145	21			
51.8	5570	(629)	1.37	I	62.5	4610	(521)	1.37	I	5	B6120	28	
			1.88	II				5	B6125	28			
			3.00	III				5	C6145	28			
37.7	7660	(865)	1.37	I	45.5	6340	(717)	1.37	I	5	B6120	39	
			1.60	II				5	B6125	39			
			3.00	III				5	C6145	39			
31.9	9050	(1020)	1.37	I	38.5	7500	(847)	1.37	I	5	B6120	46	
			1.60	II				5	B6125	46			
			2.05	III				5	C6145	46			
			3.00	III				5	D6165	46	(-)		
27.6	10400	(1180)	1.37	I	33.3	8650	(977)	1.37	I	5	B6120	53	
			1.50	II				5	B6125	53			
			2.05	III				5	C6145	53			
			3.00	III				5	D6165	53			
24.4	11800	(1340)	1.32	I	29.4	9800	(1110)	1.37	I	5	B6120	60	
			1.32	I				5	B6125	60			
			3.00	III				5	D6165	60			
19.7	14600	(1650)	1.07	I	23.8	12100	(1370)	1.07	I	5	B6120	74	
			1.07	I				5	B6125	74			
			1.50	II				5	C6145	74			
			2.05	III				5	D6165	74			
			2.62	III				5	E6175	74	(-)		
16.6	17400	(1970)	0.83	-	20.0	14400	(1630)	0.83	-	5	B6120	88	
			0.90	-				5	B6125	88			
			1.50	II				5	C6145	88			
			2.05	III				5	D6165	88			
			3.00	III				5	E6175	88	(-)		

Notes: * Y6 position is not available for ratio 11 and 18.

[1] Variable Frequency Drive (VFD) notes (see page 3.8 for Constant Torque Speed Ranges):

All 1HP+ motors require EP suffix in model number and can be used with a VFD, unless noted.

Single Reduction Selection Tables: Y5, Y6*

**5 HP
(3.7 kW)**

Standard Mounting Positions:

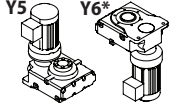

Selection Table Pages:

Single Reduction	
-Y1,Y2,Y3,Y4	3.10-3.38
-Y5,Y6	3.39-3.61
Double Reduction	
-Y1,Y2,Y3,Y4,Y5,Y6	3.62-3.79

Dimension Pages:

Single Reduction	3.80-3.85
Double Reduction	3.86-3.91

Frequency	50 Hz	60 Hz
Input Speed	1450 RPM	1750 RPM
Number of Poles	4	

50Hz				60 Hz				Selection					
Output Speed (RPM)	Output Torque		Service Factor		Output Speed (RPM)	Output Torque		Service Factor		Base		VFD ^[1]	
	in-lbs	(N·m)	SF	AGMA Class		in-lbs	(N·m)	SF	AGMA Class	Motor Power Code	Frame Size		Ratio
14.3	20200	(2280)	0.77	-	17.2	16700	(1890)	0.81	-	5	B6120	102	(-)
			0.78	-				5	B6125	102			
			1.01	I				5	C6145	102			
			2.05	III				5	D6165	102			
			3.00	III				5	E6175	102			
11.8	24400	(2750)	1.01	I	14.3	20200	(2280)	1.01	I	5	C6145	123	
			2.05	III				5	D6165	123			
9.63	29900	(3380)	1.01	I	11.6	24800	(2800)	1.01	I	5	D6165	151	
			2.05	III				5	E6175	151			
8.12	35500	(4010)	1.01	I	9.80	29400	(3320)	1.01	I	5	D6165	179	
			1.50	II				5	E6175	179			
7.02	41100	(4640)	1.01	I	8.47	34000	(3840)	1.01	I	5	D6165	207	
			1.50	II				5	E6175	207			
5.84	49400	(5580)	1.01	I	7.04	40900	(4630)	1.01	I	5	E6175	249	
4.76	60600	(6840)	1.01	I	5.75	50200	(5670)	1.01	I	5	E6175	305	

Cyclo® HBB

Selection
Tables

Notes: * Y6 position is not available for ratio 11 and 18.

[1] Variable Frequency Drive (VFD) notes (see page 3.8 for Constant Torque Speed Ranges):

All 1HP+ motors require EP suffix in model number and can be used with a VFD, unless noted.

Single Reduction Selection Tables: Y5, Y6*

**7.5 HP
(5.5 kW)**

Standard Mounting Positions:

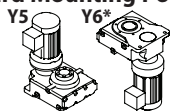

Selection Table Pages:

Single Reduction
-Y1,Y2,Y3,Y4 3.10-3.38
-Y5,Y6 3.39-3.61
Double Reduction
-Y1,Y2,Y3,Y4,Y5,Y6 3.62-3.79

Dimension Pages:

Single Reduction 3.80-3.85
Double Reduction 3.86-3.91

Frequency	50 Hz	60 Hz
Input Speed	1450 RPM	1750 RPM
Number of Poles	4	

50Hz					60 Hz					Selection			
Output Speed (RPM)	Output Torque		Service Factor		Output Speed (RPM)	Output Torque		Service Factor		Base			VFD ^[1]
	in-lbs	(N·m)	SF	AGMA Class		in-lbs	(N·m)	SF	AGMA Class	Motor Power Code	Frame Size	Ratio	
138	3100	(351)	0.92	-	167	2570	(291)	0.92	-	8	B6120	11*	
			1.13	I				1.06	I	8	B6125	11*	
			1.66	II				1.66	II	8	C6140	11*	
			1.93	II				1.93	II	8	C6145	11*	
			2.31	III				2.24	III	8	D6160	11*	
			2.66	III				2.66	III	8	D6165	11*	
82.9	5170	(584)	0.94	-	100	4290	(484)	0.94	-	8	B6120	18*	
			1.15	I				1.08	I	8	B6125	18*	
			1.72	II				1.72	II	8	C6140	18*	
			2.00	III				2.00	III	8	C6145	18*	
			2.35	III				2.28	III	8	D6160	18*	
			2.71	III				2.71	III	8	D6165	18*	
69.0	6210	(701)	0.92	-	83.3	5140	(581)	0.92	-	8	B6120	21	
			1.27	I				1.06	I	8	B6125	21	
			2.02	III				2.02	III	8	C6145	21	
51.8	8280	(935)	0.92	-	62.5	6860	(775)	0.92	-	8	B6120	28	
			1.26	I				1.26	I	8	B6125	28	
			2.02	III				2.02	III	8	C6145	28	
			2.75	III				2.75	III	8	D6165	28	
37.7	11400	(1290)	0.92	-	45.5	9430	(1070)	0.92	-	8	B6120	39	
			1.08	I				1.08	I	8	B6125	39	
			2.02	III				2.02	III	8	C6145	39	
			2.75	III				2.75	III	8	D6165	39	
31.9	13400	(1520)	0.92	-	38.5	11100	(1260)	0.92	-	8	B6120	46	
			1.08	I				1.08	I	8	B6125	46	
			1.38	I				1.38	I	8	C6145	46	
			2.02	III				2.02	III	8	D6165	46	
			2.59	III				2.59	III	8	E6175	46	
27.6	15500	(1750)	0.92	-	33.3	12900	(1450)	0.92	-	8	B6120	53	
			1.01	I				1.08	I	8	B6125	53	
			1.38	I				1.38	I	8	C6145	53	
			2.02	III				2.02	III	8	D6165	53	
			2.18	III				2.18	III	8	E6175	53	
24.4	17600	(1990)	0.89	-	29.4	14600	(1650)	0.92	-	8	B6120	60	
			0.89	-				1.03	I	8	B6125	60	
			2.02	III				2.02	III	8	D6165	60	

Notes: * Y6 position is not available for ratio 11 and 18.

[1] Variable Frequency Drive (VFD) notes (see page 3.8 for Constant Torque Speed Ranges):

All 1HP+ motors require EP suffix in model number and can be used with a VFD, unless noted.

Single Reduction Selection Tables: Y5, Y6*

7.5 HP
(5.5 kW)

Standard Mounting Positions:

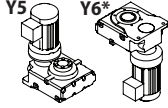

Selection Table Pages:

Single Reduction	
-Y1,Y2,Y3,Y4	3.10-3.38
-Y5,Y6	3.39-3.61
Double Reduction	
-Y1,Y2,Y3,Y4,Y5,Y6	3.62-3.79

Dimension Pages:

Single Reduction	3.80-3.85
Double Reduction	3.86-3.91

Frequency	50 Hz	60 Hz
Input Speed	1450 RPM	1750 RPM
Number of Poles	4	

50Hz				60 Hz				Selection					
Output Speed (RPM)	Output Torque		Service Factor		Output Speed (RPM)	Output Torque		Service Factor		Base		VFD ^[1]	
	in-lbs	(N·m)	SF	AGMA Class		in-lbs	(N·m)	SF	AGMA Class	Motor Power Code	Frame Size		Ratio
19.7	21700	(2450)	0.72	-	23.8	18000	(2030)	0.87	-	8	B6125	74	
			1.01	I				8	C6145	74			
			1.38	I				8	D6165	74			
			1.77	II				8	E6175	74			
16.6	25900	(2920)	1.01	I	20.0	21400	(2420)	1.01	I	8	C6145	88	
			1.38	I				8	D6165	88			
			2.02	III				8	E6175	88			
14.3	30000	(3390)	1.38	I	17.2	24900	(2810)	1.38	I	8	D6165	102	
			2.02	III				8	E6175	102			
11.8	36200	(4090)	1.38	I	14.3	30000	(3390)	1.38	I	8	D6165	123	
9.63	44500	(5030)	1.38	I	11.6	36900	(4160)	1.38	I	8	E6175	151	
8.12	52800	(5960)	1.01	I	9.80	43700	(4940)	1.01	I	8	E6175	179	
7.02	61000	(6900)	1.01	I	8.47	50600	(5710)	1.01	I	8	E6175	207	

Cyclo® HBB

Selection
Tables

Notes: * Y6 position is not available for ratio 11 and 18.

[1] Variable Frequency Drive (VFD) notes (see page 3.8 for Constant Torque Speed Ranges):

All 1HP+ motors require EP suffix in model number and can be used with a VFD, unless noted.

Single Reduction Selection Tables: Y5, Y6*

**10 HP
(7.5 kW)**

Standard Mounting Positions:

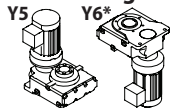

Selection Table Pages:

Single Reduction
-Y1,Y2,Y3,Y4 3.10-3.38
-Y5,Y6 3.39-3.61
Double Reduction
-Y1,Y2,Y3,Y4,Y5,Y6 3.62-3.79

Dimension Pages:

Single Reduction 3.80-3.85
Double Reduction 3.86-3.91

Frequency	50 Hz	60 Hz
Input Speed	1450 RPM	1750 RPM
Number of Poles	4	

50Hz				60 Hz				Selection					
Output Speed (RPM)	Output Torque		Service Factor		Output Speed (RPM)	Output Torque		Service Factor		Base		VFD ^[1]	
	in-lbs	(N·m)	SF	AGMA Class		in-lbs	(N·m)	SF	AGMA Class	Motor Power Code	Frame Size		Ratio
138	4230	(478)	1.22	I	167	3510	(396)	1.22	I	10	C6140	11*	
			1.41	II				10	C6145	11*			
			1.69	II				10	D6160	11*			
			1.95	II				10	D6165	11*			
			2.63	III				10	E6170	11*			
			2.86	III				10	E6175	11*			
82.9	7050	(797)	1.26	I	100	5840	(660)	1.26	I	10	C6140	18*	
			1.47	II				10	C6145	18*			
			1.72	II				10	D6160	18*			
			1.99	II				10	D6165	18*			
			2.69	III				10	E6170	18*			
			2.93	III				10	E6175	18*			
69.0	8470	(956)	1.48	II	83.3	7010	(792)	1.48	II	10	C6145	21	
51.8	11300	(1280)	0.93	-	62.5	9350	(1060)	0.93	-	10	B6125	28	
			1.48	II				10	C6145	28			
			2.02	III				10	D6165	28			
37.7	15500	(1750)	1.48	II	45.5	12900	(1450)	1.48	II	10	C6145	39	
			2.02	III				10	D6165	39			
31.9	18300	(2070)	1.01	I	38.5	15200	(1720)	1.01	I	10	C6145	46	
			1.48	II				10	D6165	46			
			1.90	II				10	E6175	46	(-)		
27.6	21200	(2390)	1.01	I	33.3	17500	(1980)	1.01	I	10	C6145	53	
			1.48	II				10	D6165	53			
			1.60	II				10	E6175	53			
24.4	24000	(2710)	1.48	II	29.4	19900	(2250)	1.48	II	10	D6165	60	
19.7	29600	(3350)	1.01	I	23.8	24500	(2770)	1.01	I	10	D6165	74	
			1.29	I				10	E6175	74			
16.6	35300	(3990)	1.01	I	20.0	29200	(3300)	1.01	I	10	D6165	88	
			1.48	II				10	E6175	88			
14.3	40900	(4620)	1.01	I	17.2	33900	(3830)	1.01	I	10	D6165	102	
			1.48	II				10	E6175	102			
11.8	49400	(5580)	1.01	I	14.3	40900	(4620)	1.01	I	10	D6165	123	
9.63	60700	(6850)	1.01	I	11.6	50300	(5680)	1.01	I	10	E6175	151	

Notes: * Y6 position is not available for ratio 11 and 18.

[1] Variable Frequency Drive (VFD) notes (see page 3.8 for Constant Torque Speed Ranges):

All 1HP+ motors require EP suffix in model number and can be used with a VFD, unless noted.

Single Reduction Selection Tables: Y5, Y6*

**15 HP
(11 kW)**

Standard Mounting Positions:

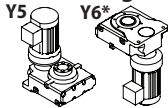

Selection Table Pages:

Single Reduction	
-Y1,Y2,Y3,Y4	3.10-3.38
-Y5,Y6	3.39-3.61
Double Reduction	
-Y1,Y2,Y3,Y4,Y5,Y6	3.62-3.79

Dimension Pages:

Single Reduction	3.80-3.85
Double Reduction	3.86-3.91

Frequency	50 Hz	60 Hz
Input Speed	1450 RPM	1750 RPM
Number of Poles	4	

50Hz				60 Hz				Selection					
Output Speed (RPM)	Output Torque		Service Factor		Output Speed (RPM)	Output Torque		Service Factor		Base		VFD ^[1]	
	in-lbs	(N·m)	SF	AGMA Class		in-lbs	(N·m)	SF	AGMA Class	Motor Power Code	Frame Size		Ratio
138	6210	(701)	0.83	-	167	5140	(581)	0.83	-	15	C6140	11*	
			0.96	-				15	C6145	11*			
			1.15	I				15	D6160	11*			
			1.33	I				15	D6165	11*			
			1.79	II				15	E6170	11*			
			1.95	II				15	E6175	11*			
82.9	10300	(1170)	0.86	-	100	8570	(969)	0.86	-	15	C6140	18*	
			1.00	I				15	C6145	18*			
			1.18	I				15	D6160	18*			
			1.36	I				15	D6165	18*			
			1.83	II				15	E6170	18*			
			2.00	III				15	E6175	18*			
69.0	12400	(1400)	1.01	I	83.3	10300	(1160)	1.01	I	15	C6145	21	
51.8	16600	(1870)	1.01	I	62.5	13700	(1550)	1.01	I	15	C6145	28	
			1.38	I				15	D6165	28			
37.7	22800	(2570)	1.01	I	45.5	18900	(2130)	1.01	I	15	C6145	39	
			1.38	I				15	D6165	39			
31.9	26900	(3040)	1.01	I	38.5	22300	(2520)	1.01	I	15	D6165	46	
			1.29	I				15	E6175	46	(-)		
27.6	31000	(3510)	1.01	I	33.3	25700	(2910)	1.01	I	15	D6165	53	
			1.09	I				15	E6175	53			
24.4	35200	(3970)	1.01	I	29.4	29100	(3290)	1.01	I	15	D6165	60	
19.7	43500	(4910)	0.88	-	23.8	36000	(4070)	0.88	-	15	E6175	74	
16.6	51700	(5840)	1.01	I	20.0	42900	(4840)	1.01	I	15	E6175	88	
14.3	60000	(6780)	1.01	I	17.2	49700	(5620)	1.01	I	15	E6175	102	

Notes: * Y6 position is not available for ratio 11 and 18.

[1] Variable Frequency Drive (VFD) notes (see page 3.8 for Constant Torque Speed Ranges):

All 1HP+ motors require EP suffix in model number and can be used with a VFD, unless noted.

Cyclo® HBB

Selection
Tables

Single Reduction Selection Tables: Y5, Y6*

**20 HP
(15 kW)**

Standard Mounting Positions:

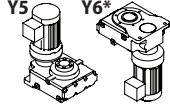

Selection Table Pages:

Single Reduction
-Y1, Y2, Y3, Y4 3.10-3.38
-Y5, Y6 3.39-3.61
Double Reduction
-Y1, Y2, Y3, Y4, Y5, Y6 3.62-3.79

Dimension Pages:

Single Reduction 3.80-3.85
Double Reduction 3.86-3.91

Frequency	50 Hz	60 Hz
Input Speed	1450 RPM	1750 RPM
Number of Poles	4	

50Hz				60 Hz				Selection					
Output Speed (RPM)	Output Torque		Service Factor		Output Speed (RPM)	Output Torque		Service Factor		Base		VFD ^[1]	
	in·lbs	(N·m)	SF	AGMA Class		in·lbs	(N·m)	SF	AGMA Class	Motor Power Code	Frame Size		Ratio
138	8470	(956)	0.85	-	167	7010	(792)	0.82	-	20	D6160	11*	
			0.98	-				20	D6165	11*			
			1.31	I				20	E6170	11*			
			1.43	II				20	E6175	11*			
82.9	14100	(1590)	0.86	-	100	11700	(1320)	0.84	-	20	D6160	18*	
			0.99	-				20	D6165	18*			
			1.35	I				20	E6170	18*			
			1.47	II				20	E6175	18*			
51.8	22600	(2550)	1.01	I	62.5	18700	(2110)	1.01	I	20	D6165	28	
37.7	31000	(3510)	1.01	I	45.5	25700	(2910)	1.01	I	20	D6165	39	
31.9	36700	(4140)	0.95	-	38.5	30400	(3430)	0.95	-	20	E6175	46	
27.6	42300	(4780)	0.80	-	33.3	35100	(3960)	0.80	-	20	E6175	53	

Cyclo® HBB

Selection
Tables

Notes: * Y6 position is not available for ratio 11 and 18.

[1] Variable Frequency Drive (VFD) notes (see page 3.8 for Constant Torque Speed Ranges):

All 1HP+ motors require EP suffix in model number and can be used with a VFD, unless noted.

Single Reduction Selection Tables: Y5, Y6*

**25 HP
(18.5 kW)**

Standard Mounting Positions:

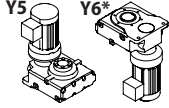

Selection Table Pages:

Single Reduction	
-Y1,Y2,Y3,Y4	3.10-3.38
-Y5,Y6	3.39-3.61
Double Reduction	
-Y1,Y2,Y3,Y4,Y5,Y6	3.62-3.79

Dimension Pages:

Single Reduction	3.80-3.85
Double Reduction	3.86-3.91

Frequency	50 Hz	60 Hz
Input Speed	1450 RPM	1750 RPM
Number of Poles	4	

50Hz					60 Hz					Selection			
Output Speed (RPM)	Output Torque		Service Factor		Output Speed (RPM)	Output Torque		Service Factor		Base			VFD ^[1]
	in-lbs	(N·m)	SF	AGMA Class		in-lbs	(N·m)	SF	AGMA Class	Motor Power Code	Frame Size	Ratio	
138	10400	(1180)	1.07	I	167	8650	(977)	1.07	I	25	E6170	11*	
			1.16	I				25	E6175	11*			
82.9	17400	(1970)	0.81	-	100	14400	(1630)	0.81	-	25	D6165	18*	
			1.09	I				25	E6170	18*			
			1.19	I				25	E6175	18*			
51.8	27800	(3150)	0.82	-	62.5	23100	(2610)	0.82	-	25	D6165	28	
37.7	38300	(4330)	0.82	-	45.5	31700	(3580)	0.82	-	25	D6165	39	

Cyclo® HBB

Selection
Tables

Notes: * Y6 position is not available for ratio 11 and 18.

[1] Variable Frequency Drive (VFD) notes (see page 3.8 for Constant Torque Speed Ranges):

All 1HP+ motors require EP suffix in model number and can be used with a VFD, unless noted.

Single Reduction Selection Tables: Y5, Y6*

**30 HP
(22 kW)**

Standard Mounting Positions:

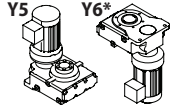

Selection Table Pages:

Single Reduction	
-Y1, Y2, Y3, Y4	3.10-3.38
-Y5, Y6	3.39-3.61
Double Reduction	
-Y1, Y2, Y3, Y4, Y5, Y6	3.62-3.79

Dimension Pages:

Single Reduction	3.80-3.85
Double Reduction	3.86-3.91

Frequency	50 Hz	60 Hz
Input Speed	1450 RPM	1750 RPM
Number of Poles	4	

Output Speed (RPM)	50Hz				60 Hz				Selection			VFD ^[1]
	Output Torque		Service Factor		Output Speed (RPM)	Output Torque		Service Factor		Base		
	in-lbs	(N·m)	SF	AGMA Class		in-lbs	(N·m)	SF	AGMA Class	Motor Power Code	Frame Size	
138	12400	(1400)	0.90	-	167	10300	(1160)	0.90	-	30	E6170	11*
			0.98	-				0.98	-	30	E6175	11*
82.9	20700	(2340)	0.92	-	100	17100	(1940)	0.92	-	30	E6170	18*
			1.00	I				1.00	I	30	E6175	18*

Cyclo® HBB

Selection
Tables

Notes: * Y6 position is not available for ratio 11 and 18.

[1] Variable Frequency Drive (VFD) notes (see page 3.8 for Constant Torque Speed Ranges):

All 1HP+ motors require EP suffix in model number and can be used with a VFD, unless noted.

Double Reduction Selection Tables: Y1,Y2,Y3,Y4,Y5,Y6

**1/8 HP
(0.1 kW)**

Standard Mounting Positions:

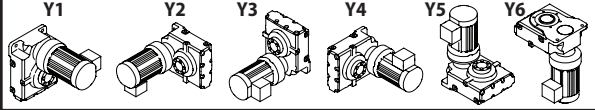

Dimension Pages:

Single Reduction 3.80-3.85
Double Reduction 3.86-3.91

Frequency	50 Hz	60 Hz
Input Speed	1450 RPM	1750 RPM
Number of Poles	4	

50Hz					60 Hz					Selection			
Output Speed (RPM)	Output Torque		Service Factor		Output Speed (RPM)	Output Torque		Service Factor		Motor Power Code	Base		VFD ^[1]
	in-lbs	(N·m)	SF	AGMA Class		in-lbs	(N·m)	SF	AGMA Class		Frame Size	Ratio	
3.98	1960	(221)	2.08	III	4.81	1620	(183)	2.51	III	01	Z609DA	364	(a)
3.42	2280	(257)	1.79	II	4.13	1890	(213)	2.16	III	01	Z609DA	424	(a)
2.90	2690	(304)	1.52	II	3.50	2230	(252)	1.83	II	01	Z609DA	501	(a)
			3.06	III				01	A610DA	501	(a)		
2.51	3100	(351)	1.31	I	3.03	2570	(291)	1.58	II	01	Z609DA	578	(a)
			2.66	III				01	A610DA	578	(a)		
2.12	3670	(414)	1.11	I	2.56	3040	(343)	1.34	I	01	Z609DA	683	(a)
			2.25	III				01	A610DA	683	(a)		
1.79	4350	(491)	0.94	-	2.16	3600	(407)	1.13	I	01	Z609DA	809	(a)
			1.90	II				01	A610DA	809	(a)		
1.52	5140	(580)	0.79	-	1.83	4260	(481)	0.96	-	01	Z609DA	956	(a)
			1.61	II				01	A610DA	956	(a)		
1.30	6000	(678)	0.68	-	1.57	4970	(562)	0.82	-	01	Z609DA	1117	(a)
			1.37	I				01	A610DA	1117	(a)		
			2.75	III				01	B612DA	1117	(a)		
1.10	7090	(801)	0.57	-	1.33	5880	(664)	0.69	-	01	Z609DA	1320	(a)
			1.16	I				01	A610DA	1320	(a)		
			2.33	III				01	B612DA	1320	(a)		
0.876	8900	(1010)	0.46	-	1.06	7370	(833)	0.55	-	01	Z609DA	1656	(a)
			0.93	-				01	A610DA	1656	(a)		
			1.86	II				01	B612DA	1656	(a)		
0.741	10500	(1190)	0.78	-	0.894	8710	(984)	0.95	-	01	A610DA	1957	(a)
			1.57	II				01	B612DA	1957	(a)		
			3.14	III				01	C614DB	1957	(a)		
0.638	12200	(1380)	0.68	-	0.770	10100	(1140)	0.82	-	01	A610DA	2272	(a)
			1.35	I				01	B612DA	2272	(a)		
			2.70	III				01	C614DB	2272	(a)		
0.567	13800	(1550)	0.60	-	0.684	11400	(1290)	0.72	-	01	A610DA	2559	(a)
			1.20	I				01	B612DA	2559	(a)		
			2.40	III				01	C614DB	2559	(a)		
0.493	15800	(1790)	0.52	-	0.595	13100	(1480)	0.63	-	01	A610DA	2944	(a)
			1.04	I				01	B612DA	2944	(a)		
			2.09	III				01	C614DB	2944	(a)		
0.413	18900	(2130)	0.44	-	0.499	15600	(1770)	0.53	-	01	A610DA	3511	(a)
			0.87	-				01	B612DA	3511	(a)		
0.332	23500	(2650)	0.70	-	0.401	19400	(2200)	0.85	-	01	B612DA	4365	(a)
0.280	27800	(3140)	0.59	-	0.338	23100	(2600)	0.72	-	01	B612DA	5177	(a)
0.224	34800	(3930)	0.47	-	0.270	28800	(3260)	0.57	-	01	B612DA	6472	(a)
0.201	38800	(4390)	0.42	-	0.242	32200	(3640)	0.51	-	01	B612DA	7228	(a)

Notes: [1] Variable Frequency Drive (VFD) notes (see page 3.8 for Constant Torque Speed Ranges):
 (-) = For Inverter Operation, starting condition may require ambient temperature of 5° C or higher.
 (a) = Both AV and non-AV motors can be used for selection.

Cyclo® HBB

Selection
Tables

Double Reduction Selection Tables: Y1,Y2,Y3,Y4,Y5,Y6

**1/4 HP
(0.2 kW)**

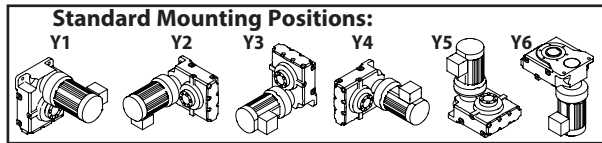

Dimension Pages:
Single Reduction 3.80-3.85
Double Reduction 3.86-3.91

Frequency	50 Hz	60 Hz
Input Speed	1450 RPM	1750 RPM
Number of Poles	4	

50Hz					60 Hz					Selection			
Output Speed (RPM)	Output Torque		Service Factor		Output Speed (RPM)	Output Torque		Service Factor		Motor Power Code	Base		VFD ^[1]
	in-lbs	(N·m)	SF	AGMA Class		in-lbs	(N·m)	SF	AGMA Class		Frame Size	Ratio	
3.98	3910	(442)	1.04	I	4.81	3240	(366)	1.26	I	02	Z609DA	364	(a)
			2.11	III				2.15	III		A610DA	364	(a)
3.42	4550	(514)	0.90	-	4.13	3770	(426)	1.08	I	02	Z609DA	424	(a)
			1.81	II				2.15	III		A610DA	424	(a)
2.90	5380	(608)	0.76	-	3.50	4460	(504)	0.91	-	02	Z609DA	501	(a)
			1.53	II				1.85	II		A610DA	501	(a)
			2.15	III				2.15	III		B612DA	501	(a)
			3.07	III				3.70	III		B612DB	501	(a)
2.51	6210	(701)	0.66	-	3.03	5140	(581)	0.79	-	02	Z609DA	578	(a)
			1.33	I				1.60	II		A610DA	578	(a)
			2.15	III				2.15	III		B612DA	578	(a)
			2.66	III				3.21	III		B612DB	578	(a)
2.12	7340	(829)	0.56	-	2.56	6080	(687)	0.67	-	02	Z609DA	683	(a)
			1.12	I				1.36	I		A610DA	683	(a)
			2.15	III				2.15	III		B612DA	683	(a)
			2.25	III				2.72	III		B612DB	683	(a)
1.79	8690	(982)	0.47	-	2.16	7200	(814)	0.57	-	02	Z609DA	809	(a)
			0.95	-				1.14	I		A610DA	809	(a)
			1.90	II				2.15	III		B612DA	809	(a)
			1.90	II				2.29	III		B612DB	809	(a)
1.52	10300	(1160)	0.80	-	1.83	8510	(962)	0.97	-	02	A610DA	956	(a)
			1.61	II				1.94	II		B612DB	956	(a)
			2.15	III				2.15	III		C614DA	956	(a)
1.30	12000	(1360)	0.69	-	1.57	9940	(1120)	0.83	-	02	A610DA	1117	(a)
			1.38	I				1.66	II		B612DB	1117	(a)
			2.15	III				2.15	III		C614DA	1117	(a)
			2.75	III				3.32	III		C614DB	1117	(a)
1.10	14200	(1600)	0.58	-	1.33	11800	(1330)	0.70	-	02	A610DA	1320	(a)
			1.16	I				1.40	II		B612DB	1320	(a)
			2.15	III				2.15	III		C614DA	1320	(a)
			2.33	III				2.81	III		C614DB	1320	(a)
0.876	17800	(2010)	0.46	-	1.06	14700	(1670)	0.56	-	02	A610DA	1656	(a)
			0.93	-				1.12	I		B612DB	1656	(a)
			1.86	II				2.15	III		C614DA	1656	(a)
			1.86	II				2.24	III		C614DB	1656	(a)
0.741	21000	(2380)	0.78	-	0.894	17400	(1970)	0.95	-	02	B612DB	1957	(a)
			1.57	II				1.89	II		C614DB	1957	(a)
			2.72	III				3.29	III		D616DA	1957	(a)

Notes: [1] Variable Frequency Drive (VFD) notes (see page 3.8 for Constant Torque Speed Ranges):
 (-) = For Inverter Operation, starting condition may require ambient temperature of 5° C or higher.
 (a) = Both AV and non-AV motors can be used for selection.

Cyclo® HBB

Selection
Tables

Double Reduction Selection Tables: Y1,Y2,Y3,Y4,Y5,Y6

**1/4 HP
(0.2 kW)**

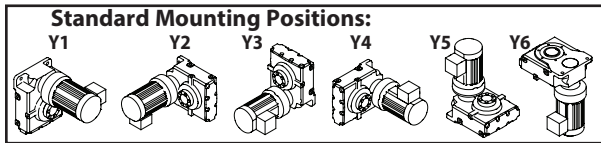

Dimension Pages:
Single Reduction 3.80-3.85
Double Reduction 3.86-3.91

Frequency	50 Hz	60 Hz
Input Speed	1450 RPM	1750 RPM
Number of Poles	4	

50Hz				60 Hz				Selection					
Output Speed (RPM)	Output Torque		Service Factor		Output Speed (RPM)	Output Torque		Service Factor		Base		VFD ^[1]	
	in·lbs	(N·m)	SF	AGMA Class		in·lbs	(N·m)	SF	AGMA Class	Motor Power Code	Frame Size		Ratio
0.638	24400	(2760)	0.68	-	0.770	20200	(2290)	0.82	-	02	B612DB	2272	(a)
			1.35	I				1.63	II	02	C614DB	2272	(a)
			2.35	III				2.83	III	02	D616DA	2272	(a)
0.567	27500	(3110)	0.60	-	0.684	22800	(2570)	0.72	-	02	B612DB	2559	(a)
			1.20	I				1.45	II	02	C614DB	2559	(a)
			2.08	III				2.51	III	02	D616DA	2559	(a)
			2.91	III				3.51	III	02	E617DA	2559	(a)
0.493	31600	(3570)	0.52	-	0.595	26200	(2960)	0.63	-	02	B612DB	2944	(a)
			1.04	I				1.26	I	02	C614DB	2944	(a)
			2.53	III				3.05	III	02	E617DA	2944	(a)
0.413	37700	(4260)	0.44	-	0.499	31300	(3530)	0.53	-	02	B612DB	3511	(a)
			0.87	-				1.06	I	02	C614DB	3511	(a)
0.332	46900	(5300)	0.70	-	0.401	38900	(4390)	0.85	-	02	C614DB	4365	(a)
0.280	55600	(6290)	0.59	-	0.338	46100	(5210)	0.72	-	02	C614DB	5177	(a)
0.224	69600	(7860)	0.47	-	0.270	57600	(6510)	0.57	-	02	C614DB	6472	(a)
0.201	77700	(8780)	0.42	-	0.242	64400	(7270)	0.51	-	02	C614DB	7228	(a)
			0.74	-				0.89	-	02	D616DA	7228	(a)
0.163	95400	(10800)	0.60	-	0.197	79100	(8940)	0.72	-	02	D616DA	8880	(a)
0.136	115000	(12900)	0.50	-	0.164	94900	(10700)	0.60	-	02	D616DA	10658	(a)
			0.70	-				0.84	-	02	E617DA	10658	(a)
0.119	131000	(14800)	0.44	-	0.144	109000	(12300)	0.53	-	02	D616DA	12184	(a)
			0.61	-				0.74	-	02	E617DA	12184	(a)
0.0934	167000	(18900)	0.48	-	0.113	138000	(15600)	0.58	-	02	E617DA	15530	(a)
0.0807	193000	(21800)	0.41	-	0.0974	160000	(18100)	0.50	-	02	E617DA	17966	(a)

Notes: [1] Variable Frequency Drive (VFD) notes (see page 3.8 for Constant Torque Speed Ranges):
 (-) = For Inverter Operation, starting condition may require ambient temperature of 5° C or higher.
 (a) = Both AV and non-AV motors can be used for selection.

Double Reduction Selection Tables: Y1,Y2,Y3,Y4,Y5,Y6

**1/3 HP
(0.25 kW)**

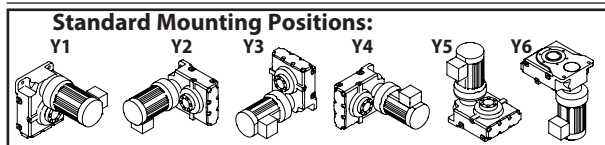

Dimension Pages:
Single Reduction 3.80-3.85
Double Reduction 3.86-3.91

Frequency	50 Hz	60 Hz
Input Speed	1450 RPM	1750 RPM
Number of Poles	4	

50Hz				60 Hz				Selection					
Output Speed (RPM)	Output Torque		Service Factor		Output Speed (RPM)	Output Torque		Service Factor		Motor Power Code	Base		VFD ^[1]
	in-lbs	(N·m)	SF	AGMA Class		in-lbs	(N·m)	SF	AGMA Class		Frame Size	Ratio	
3.98	4890	(553)	0.83	-	4.81	4050	(458)	1.01	I	03	Z609DA	364	(a)
			1.69	II				03	A610DA		364	(a)	
3.42	5690	(643)	0.72	-	4.13	4710	(533)	0.86	-	03	Z609DA	424	(a)
			1.45	II				03	A610DA		424	(a)	
			2.90	III				03	B612DB		424	(a)	
2.90	6720	(760)	0.61	-	3.50	5570	(630)	0.73	-	03	Z609DA	501	(a)
			1.23	I				03	A610DA		501	(a)	
			1.72	II				03	B612DA		501	(a)	
			2.45	III				03	B612DB		501	(a)	
2.51	7760	(877)	0.53	-	3.03	6430	(726)	0.63	-	03	Z609DA	578	(a)
			1.06	I				03	A610DA		578	(a)	
			1.72	II				03	B612DA		578	(a)	
			2.13	III				03	B612DB		578	(a)	
2.12	9170	(1040)	0.44	-	2.56	7600	(859)	0.54	-	03	Z609DA	683	(a)
			0.90	-				03	A610DA		683	(a)	
			1.72	II				03	B612DA		683	(a)	
			1.80	II				03	B612DB		683	(a)	
1.79	10900	(1230)	0.76	-	2.16	9000	(1020)	0.92	-	03	A610DA	809	(a)
			1.52	II				03	B612DA		809	(a)	
			1.52	II				03	B612DB		809	(a)	
			3.04	III				03	C614DB		809	(a)	
1.52	12800	(1450)	0.64	-	1.83	10600	(1200)	0.78	-	03	A610DA	956	(a)
			1.29	I				03	B612DB		956	(a)	
			1.72	II				03	C614DA		956	(a)	
			2.57	III				03	C614DB		956	(a)	
1.30	15000	(1690)	0.55	-	1.57	12400	(1400)	0.66	-	03	A610DA	1117	(a)
			1.10	I				03	B612DB		1117	(a)	
			1.72	II				03	C614DA		1117	(a)	
			2.20	III				03	C614DB		1117	(a)	
1.10	17700	(2000)	0.47	-	1.33	14700	(1660)	0.56	-	03	A610DA	1320	(a)
			0.93	-				03	B612DB		1320	(a)	
			1.72	II				03	C614DA		1320	(a)	
			1.86	II				03	C614DB		1320	(a)	
0.876	22200	(2510)	0.74	-	1.06	18400	(2080)	0.90	-	03	B612DB	1656	(a)
			1.48	II				03	C614DA		1656	(a)	
			1.48	II				03	C614DB		1656	(a)	
			2.57	III				03	D616DA		1656	(a)	

Cyclo® HBB

Selection
Tables

Notes: [1] Variable Frequency Drive (VFD) notes (see page 3.8 for Constant Torque Speed Ranges):
 (-) = For Inverter Operation, starting condition may require ambient temperature of 5° C or higher.
 (a) = Both AV and non-AV motors can be used for selection.

Double Reduction Selection Tables: Y1,Y2,Y3,Y4,Y5,Y6

**1/3 HP
(0.25 kW)**

Standard Mounting Positions:

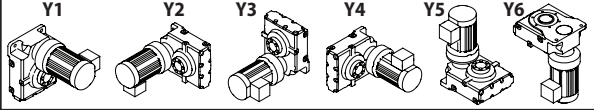

Dimension Pages:

Single Reduction 3.80-3.85
Double Reduction 3.86-3.91

Frequency	50 Hz	60 Hz
Input Speed	1450 RPM	1750 RPM
Number of Poles	4	

50Hz				60 Hz				Selection					
Output Speed (RPM)	Output Torque		Service Factor		Output Speed (RPM)	Output Torque		Service Factor		Base		VFD ^[1]	
	in-lbs	(N·m)	SF	AGMA Class		in-lbs	(N·m)	SF	AGMA Class	Motor Power Code	Frame Size		Ratio
0.741	26300	(2970)	0.63	-	0.894	21800	(2460)	0.76	-	03	B612DB	1957	(a)
			1.26	I				1.52	II	03	C614DB	1957	(a)
			2.18	III				2.63	III	03	D616DA	1957	(a)
			3.04	III				3.67	III	03	E617DA	1957	(a)
0.638	30500	(3450)	0.54	-	0.770	25300	(2860)	0.65	-	03	B612DB	2272	(a)
			1.08	I				1.31	I	03	C614DB	2272	(a)
			1.88	II				2.26	III	03	D616DA	2272	(a)
			2.62	III				3.16	III	03	E617DA	2272	(a)
0.567	34400	(3880)	0.48	-	0.684	28500	(3220)	0.58	-	03	B612DB	2559	(a)
			0.96	-				1.16	I	03	C614DB	2559	(a)
			1.67	II				2.01	III	03	D616DA	2559	(a)
			2.32	III				2.81	III	03	E617DA	2559	(a)
0.493	39600	(4470)	0.42	-	0.595	32800	(3700)	0.50	-	03	B612DB	2944	(a)
			0.83	-				1.01	I	03	C614DB	2944	(a)
			2.02	III				2.44	III	03	E617DA	2944	(a)
0.413	47200	(5330)	0.70	-	0.499	39100	(4420)	0.84	-	03	C614DB	3511	(a)
0.332	58600	(6630)	0.56	-	0.401	48600	(5490)	0.68	-	03	C614DB	4365	(a)
0.280	69600	(7860)	0.47	-	0.338	57600	(6510)	0.57	-	03	C614DB	5177	(a)
0.201	97100	(11000)	0.59	-	0.242	80500	(9090)	0.71	-	03	D616DA	7228	(a)
0.163	119000	(13500)	0.48	-	0.197	98900	(11200)	0.58	-	03	D616DA	8880	(a)
0.136	143000	(16200)	0.56	-	0.164	119000	(13400)	0.67	-	03	E617DA	10658	(a)
0.119	164000	(18500)	0.49	-	0.144	136000	(15300)	0.59	-	03	E617DA	12184	(a)

Cydo® HBB

Selection
Tables

Notes: [1] Variable Frequency Drive (VFD) notes (see page 3.8 for Constant Torque Speed Ranges):
 (-) = For Inverter Operation, starting condition may require ambient temperature of 5° C or higher.
 (a) = Both AV and non-AV motors can be used for selection.

Double Reduction Selection Tables: Y1,Y2,Y3,Y4,Y5,Y6

**1/2 HP
(0.4 kW)**

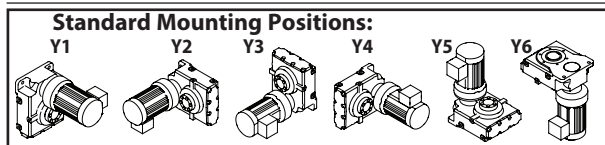

Dimension Pages:
Single Reduction 3.80-3.85
Double Reduction 3.86-3.91

Frequency	50 Hz	60 Hz
Input Speed	1450 RPM	1750 RPM
Number of Poles	4	

50Hz					60 Hz					Selection			
Output Speed (RPM)	Output Torque		Service Factor		Output Speed (RPM)	Output Torque		Service Factor		Motor Power Code	Base		VFD ^[1]
	in-lbs	(N·m)	SF	AGMA Class		in-lbs	(N·m)	SF	AGMA Class		Frame Size	Ratio	
3.98	7830	(884)	0.52	-	4.81	6480	(733)	0.63	-	05	Z609DA	364	(a)
			1.05	I				1.07	I	05	A610DA	364	
			2.11	III				2.55	III	05	B612DB	364	
3.42	9100	(1030)	0.45	-	4.13	7540	(852)	0.54	-	05	Z609DA	424	(a)
			0.91	-				1.07	I	05	A610DA	424	
			1.81	II				2.19	III	05	B612DB	424	
2.90	10800	(1220)	0.77	-	3.50	8920	(1010)	0.92	-	05	A610DA	501	(a)
			1.07	I				1.07	I	05	B612DA	501	
			1.53	II				1.85	II	05	B612DB	501	
			3.07	III				3.70	III	05	C614DB	501	
2.51	12400	(1400)	0.66	-	3.03	10300	(1160)	0.80	-	05	A610DA	578	(a)
			1.07	I				1.07	I	05	B612DA	578	
			1.33	I				1.60	II	05	B612DB	578	
			2.66	III				3.21	III	05	C614DB	578	
2.12	14700	(1660)	0.56	-	2.56	12200	(1370)	0.68	-	05	A610DA	683	(a)
			1.07	I				1.07	I	05	B612DA	683	
			1.13	I				1.36	I	05	B612DB	683	
			2.25	III				2.72	III	05	C614DB	683	
1.79	17400	(1960)	0.47	-	2.16	14400	(1630)	0.57	-	05	A610DA	809	(a)
			0.95	-				1.07	I	05	B612DA	809	
			0.95	-				1.15	I	05	B612DB	809	
			1.90	II				2.29	III	05	C614DB	809	
1.52	20500	(2320)	0.80	-	1.83	17000	(1920)	0.97	-	05	B612DB	956	(a)
			1.07	I				1.07	I	05	C614DA	956	
			1.61	II				1.94	II	05	C614DB	956	
			2.79	III				3.36	III	05	D616DA	956	
1.30	24000	(2710)	0.69	-	1.57	19900	(2250)	0.83	-	05	B612DA	1117	(a)
			1.07	I				1.07	I	05	C614DA	1117	
			1.38	I				1.66	II	05	C614DB	1117	
			2.39	III				2.88	III	05	D616DA	1117	
1.10	28400	(3210)	0.58	-	1.33	23500	(2660)	0.70	-	05	B612DA	1320	(a)
			1.07	I				1.07	I	05	C614DA	1320	
			1.16	I				1.40	II	05	C614DB	1320	
			2.02	III				2.44	III	05	D616DA	1320	
			2.82	III				3.40	III	05	E617DA	1320	

Cyclo® HBB

Selection
Tables

Notes: [1] Variable Frequency Drive (VFD) notes (see page 3.8 for Constant Torque Speed Ranges):
 (-) = For Inverter Operation, starting condition may require ambient temperature of 5° C or higher.
 (a) = Both AV and non-AV motors can be used for selection.

Double Reduction Selection Tables: Y1,Y2,Y3,Y4,Y5,Y6

**1/2 HP
(0.4 kW)**

Standard Mounting Positions:

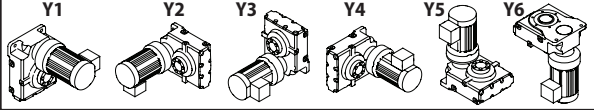

Dimension Pages:

Single Reduction 3.80-3.85
Double Reduction 3.86-3.91

Frequency	50 Hz	60 Hz
Input Speed	1450 RPM	1750 RPM
Number of Poles	4	

50Hz				60 Hz				Selection					
Output Speed (RPM)	Output Torque		Service Factor		Output Speed (RPM)	Output Torque		Service Factor		Base		VFD ^[1]	
	in-lbs	(N·m)	SF	AGMA Class		in-lbs	(N·m)	SF	AGMA Class	Motor Power Code	Frame Size		Ratio
0.876	35600	(4020)	0.46	-	1.06	29500	(3330)	0.56	-	05	B612DA	1656	
			0.93	-				1.07	I	05	C614DA	1656	
			0.93	-				1.12	I	05	C614DB	1656	(a)
			1.61	II				1.94	II	05	D616DA	1656	(a)
			2.25	III				2.71	III	05	E617DA	1656	(a)
0.741	42100	(4750)	0.78	-	0.894	34900	(3940)	0.95	-	05	C614DB	1957	(a)
			1.36	I				1.64	II	05	D616DA	1957	(a)
			1.90	II				2.29	III	05	E617DA	1957	(a)
0.638	48800	(5520)	0.68	-	0.770	40500	(4570)	0.82	-	05	C614DB	2272	(a)
			1.17	I				1.42	II	05	D616DA	2272	(a)
			1.64	II				1.98	II	05	E617DA	2272	(a)
0.567	55000	(6210)	0.60	-	0.684	45600	(5150)	0.72	-	05	C614DB	2559	(a)
			1.04	I				1.26	I	05	D616DA	2559	(a)
			1.45	II				1.75	II	05	E617DA	2559	(a)
0.493	63300	(7150)	0.52	-	0.595	52400	(5920)	0.63	-	05	C614DB	2944	(a)
			0.90	-				1.09	I	05	D616DA	2944	(a)
			1.26	I				1.52	II	05	E617DA	2944	(a)
0.413	75500	(8530)	0.44	-	0.499	62500	(7070)	0.53	-	05	C614DB	3511	(a)
			0.76	-				0.92	-	05	D616DA	3511	(a)
			1.06	I				1.28	I	05	E617DA	3511	(a)
0.332	93800	(10600)	0.61	-	0.401	77700	(8780)	0.74	-	05	D616DA	4365	(a)
			0.85	-				1.03	I	05	E617DA	4365	(a)
0.280	111000	(12600)	0.51	-	0.338	92200	(10400)	0.62	-	05	D616DA	5177	(a)
			0.72	-				0.87	-	05	E617DA	5177	(a)
0.224	139000	(15700)	0.41	-	0.270	115000	(13000)	0.50	-	05	D616DA	6472	(a)
			0.57	-				0.69	-	05	E617DA	6472	(a)
0.201	155000	(17600)	0.51	-	0.242	129000	(14500)	0.62	-	05	E617DA	7228	(a)
0.163	191000	(21600)	0.42	-	0.197	158000	(17900)	0.51	-	05	E617DA	8880	(a)

Cyclo® HBB

Selection Tables

Notes: [1] Variable Frequency Drive (VFD) notes (see page 3.8 for Constant Torque Speed Ranges):
 (-) = For Inverter Operation, starting condition may require ambient temperature of 5° C or higher.
 (a) = Both AV and non-AV motors can be used for selection.

Double Reduction Selection Tables: Y1,Y2,Y3,Y4,Y5,Y6

**3/4 HP
(0.55 kW)**

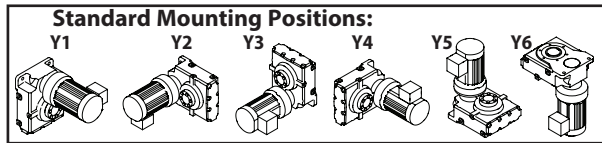

Dimension Pages:
Single Reduction 3.80-3.85
Double Reduction 3.86-3.91

Frequency	50 Hz	60 Hz
Input Speed	1450 RPM	1750 RPM
Number of Poles	4	

50Hz					60 Hz					Selection			
Output Speed (RPM)	Output Torque		Service Factor		Output Speed (RPM)	Output Torque		Service Factor		Motor Power Code	Base		VFD ^[1]
	in-lbs	(N·m)	SF	AGMA Class		in-lbs	(N·m)	SF	AGMA Class		Frame Size	Ratio	
3.98	10800	(1220)	1.53	II	4.81	8920	(1010)	1.85	II	08	B612DB	364	(a)
			2.91	III				2.91	III		C614DB	364	(a)
			3.07	III				3.70	III		C614DC	364	(a),(-)
3.42	12500	(1410)	1.32	I	4.13	10400	(1170)	1.59	II	08	B612DB	424	(a)
			2.64	III				2.91	III		C614DB	424	(a)
			2.64	III				3.18	III		C614DC	424	(a),(-)
2.90	14800	(1670)	1.12	I	3.50	12300	(1390)	1.35	I	08	B612DB	501	(a)
			2.23	III				2.69	III		C614DB	501	(a)
			2.91	III				2.91	III		D616DA	501	(a)
2.51	17100	(1930)	0.97	-	3.03	14100	(1600)	1.17	I	08	B612DB	578	(a)
			1.93	II				2.33	III		C614DB	578	(a)
			2.91	III				2.91	III		D616DA	578	(a)
2.12	20200	(2280)	0.82	-	2.56	16700	(1890)	0.99	-	08	B612DB	683	(a)
			1.64	II				1.97	II		C614DB	683	(a)
			2.84	III				2.91	III		D616DA	683	(a)
			2.84	III				3.43	III		D616DB	683	(a)
1.79	23900	(2700)	0.69	-	2.16	19800	(2240)	0.83	-	08	B612DB	809	(a)
			1.38	I				1.67	II		C614DB	809	(a)
			2.40	III				2.89	III		D616DA	809	(a)
			2.91	III				2.91	III		E617DA	809	(a)
1.52	28200	(3190)	0.58	-	1.83	23400	(2640)	0.71	-	08	B612DB	956	(a)
			1.17	I				1.41	II		C614DB	956	(a)
			2.03	III				2.45	III		D616DA	956	(a)
			2.83	III				2.91	III		E617DA	956	(a)
			2.83	III				3.42	III		E617DB	956	(a)
1.30	33000	(3730)	0.50	-	1.57	27300	(3090)	0.60	-	08	B612DB	1117	(a)
			1.00	I				1.21	I		C614DB	1117	(a)
			1.74	II				2.09	III		D616DA	1117	(a)
			2.42	III				2.91	III		E617DA	1117	(a)
1.10	39000	(4410)	0.42	-	1.33	32300	(3650)	0.51	-	08	B612DB	1320	(a)
			0.85	-				1.02	I		C614DB	1320	(a)
			1.47	II				1.77	II		D616DA	1320	(a)
			2.05	III				2.47	III		E617DA	1320	(a)
0.876	48900	(5530)	0.67	-	1.06	40500	(4580)	0.81	-	08	C614DB	1656	(a)
			1.17	I				1.41	II		D616DA	1656	(a)
			1.63	II				1.97	II		E617DA	1656	(a)

Notes: [1] Variable Frequency Drive (VFD) notes (see page 3.8 for Constant Torque Speed Ranges):
 (-) = For Inverter Operation, starting condition may require ambient temperature of 5° C or higher.
 (a) = Both AV and non-AV motors can be used for selection.

Cyclo® HBB

Selection
Tables

Double Reduction Selection Tables: Y1,Y2,Y3,Y4,Y5,Y6

**3/4 HP
(0.55 kW)**

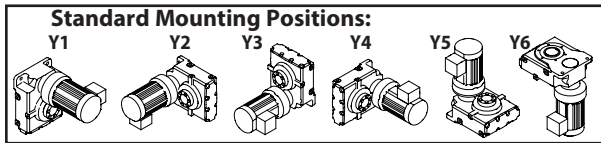

Dimension Pages:
Single Reduction 3.80-3.85
Double Reduction 3.86-3.91

Frequency	50 Hz	60 Hz
Input Speed	1450 RPM	1750 RPM
Number of Poles	4	

50Hz					60 Hz					Selection			
Output Speed (RPM)	Output Torque		Service Factor		Output Speed (RPM)	Output Torque		Service Factor		Motor Power Code	Base		VFD ^[1]
	in-lbs	(N·m)	SF	AGMA Class		in-lbs	(N·m)	SF	AGMA Class		Frame Size	Ratio	
0.741	57800	(6530)	0.57	-	0.894	47900	(5410)	0.69	-	08	C614DB	1957	(a)
			0.99	-				08	D616DA	1957	(a)		
			1.38	I				08	E617DA	1957	(a)		
0.638	67100	(7590)	0.49	-	0.770	55600	(6290)	0.59	-	08	C614DB	2272	(a)
			0.85	-				08	D616DA	2272	(a)		
			1.19	I				08	E617DA	2272	(a)		
0.567	75600	(8550)	0.44	-	0.684	62700	(7080)	0.53	-	08	C614DB	2559	(a)
			0.76	-				08	D616DA	2559	(a)		
			1.06	I				08	E617DA	2559	(a)		
0.493	87000	(9830)	0.66	-	0.595	72100	(8150)	0.79	-	08	D616DA	2944	(a)
			0.92	-				08	E617DA	2944	(a)		
0.413	104000	(11700)	0.55	-	0.499	86000	(9710)	0.67	-	08	D616DA	3511	(a)
			0.77	-				08	E617DA	3511	(a)		
0.332	129000	(14600)	0.44	-	0.401	107000	(12100)	0.54	-	08	D616DA	4365	(a)
			0.62	-				08	E617DA	4365	(a)		
0.280	153000	(17300)	0.52	-	0.338	127000	(14300)	0.63	-	08	E617DA	5177	(a)
0.224	191000	(21600)	0.42	-	0.270	159000	(17900)	0.50	-	08	E617DA	6472	(a)

Cydo® HBB

Selection
Tables

Notes: [1] Variable Frequency Drive (VFD) notes (see page 3.8 for Constant Torque Speed Ranges):
(-) = For Inverter Operation, starting condition may require ambient temperature of 5° C or higher.
(a) = Both AV and non-AV motors can be used for selection.

Double Reduction Selection Tables: Y1,Y2,Y3,Y4,Y5,Y6

**1 HP
(0.75 kW)**

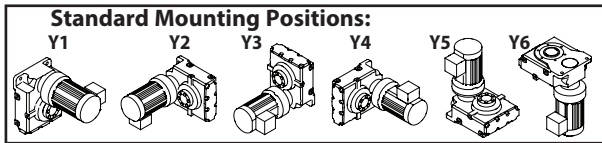

Dimension Pages:
Single Reduction 3.80-3.85
Double Reduction 3.86-3.91

Frequency	50 Hz	60 Hz
Input Speed	1450 RPM	1750 RPM
Number of Poles	4	

50Hz				60 Hz				Selection				
Output Speed (RPM)	Output Torque		Service Factor		Output Speed (RPM)	Output Torque		Service Factor		Base		VFD ^[1]
	in-lbs	(N·m)	SF	AGMA Class		in-lbs	(N·m)	SF	AGMA Class	Motor Power Code	Frame Size	
3.98	14700	(1660)	1.13	I	4.81	12200	(1370)	1.36	I	1	B612DB	364
			2.13	III				1	C614DB	364		
			2.25	III				1	C614DC	364		
3.42	17100	(1930)	0.97	-	4.13	14100	(1600)	1.17	I	1	B612DB	424
			1.93	II				1	C614DB	424		
			1.93	II				1	C614DC	424		
2.90	20200	(2280)	0.82	-	3.50	16700	(1890)	0.99	-	1	B612DB	501
			1.64	II				1	C614DB	501		
			2.13	III				1	D616DA	501		
			2.84	III				1	D616DB	501		
2.51	23300	(2630)	0.71	-	3.03	19300	(2180)	0.86	-	1	B612DB	578
			1.42	II				1	C614DB	578		
			2.13	III				1	D616DA	578		
			2.46	III				1	D616DB	578		
2.12	27500	(3110)	0.60	-	2.56	22800	(2580)	0.72	-	1	B612DB	683
			1.20	I				1	C614DB	683		
			2.08	III				1	D616DA	683		
			2.08	III				1	D616DB	683		
			2.91	III				1	E617DB	683		
1.79	32600	(3680)	0.51	-	2.16	27000	(3050)	0.61	-	1	B612DB	809
			1.01	I				1	C614DB	809		
			1.76	II				1	D616DA	809		
			2.13	III				1	E617DA	809		
			2.45	III				1	E617DB	809		
1.52	38500	(4350)	0.43	-	1.83	31900	(3610)	0.52	-	1	B612DB	956
			0.86	-				1	C614DB	956		
			1.49	II				1	D616DA	956		
			2.08	III				1	E617DA	956		
			2.08	III				1	E617DB	956		
1.30	45000	(5080)	0.73	-	1.57	37300	(4210)	0.89	-	1	C614DB	1117
			1.27	I				1	D616DA	1117		
			1.78	II				1	E617DA	1117		
1.10	53200	(6010)	0.62	-	1.33	44100	(4980)	0.75	-	1	C614DB	1320
			1.08	I				1	D616DA	1320		
			1.50	II				1	E617DA	1320		
0.876	66700	(7540)	0.49	-	1.06	55300	(6250)	0.60	-	1	C614DB	1656
			0.86	-				1	D616DA	1656		
			1.20	I				1	E617DA	1656		

Notes: [1] Variable Frequency Drive (VFD) notes (see page 3.8 for Constant Torque Speed Ranges):
 (-) = For Inverter Operation, starting condition may require ambient temperature of 5° C or higher.
 (a) = Both AV and non-AV motors can be used for selection.

Cyclo® HBB
Selection
Tables

Double Reduction Selection Tables: Y1,Y2,Y3,Y4,Y5,Y6

**1 HP
(0.75 kW)**

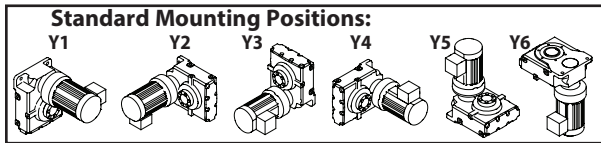

Dimension Pages:
Single Reduction 3.80-3.85
Double Reduction 3.86-3.91

Frequency	50 Hz	60 Hz
Input Speed	1450 RPM	1750 RPM
Number of Poles	4	

Output Speed (RPM)	50Hz				60 Hz				Selection			VFD ^[1]
	Output Torque		Service Factor		Output Torque		Service Factor		Base			
	in-lbs	(N·m)	SF	AGMA Class	in-lbs	(N·m)	SF	AGMA Class	Motor Power Code	Frame Size	Ratio	
0.741	78900	(8910)	0.42	-	0.894	65300	(7380)	0.51	-	1	C614DB	1957
			0.73	-				1	D616DA	1957		
			1.01	I				1	E617DA	1957		
0.638	91600	(10300)	0.63	-	0.770	75900	(8570)	0.75	-	1	D616DA	2272
			0.87	-				1	E617DA	2272		
0.567	103000	(11700)	0.56	-	0.684	85500	(9650)	0.67	-	1	D616DA	2559
			0.77	-				1	E617DA	2559		
0.493	119000	(13400)	0.48	-	0.595	98300	(11100)	0.58	-	1	D616DA	2944
			0.67	-				1	E617DA	2944		
0.413	142000	(16000)	0.56	-	0.499	117000	(13200)	0.68	-	1	E617DA	3511
0.332	176000	(19900)	0.45	-	0.401	146000	(16500)	0.55	-	1	E617DA	4365

Cyclo® HBB

Selection
Tables

Notes: [1] Variable Frequency Drive (VFD) notes (see page 3.8 for Constant Torque Speed Ranges):
 (-) = For Inverter Operation, starting condition may require ambient temperature of 5° C or higher.
 (a) = Both AV and non-AV motors can be used for selection.

Double Reduction Selection Tables: Y1,Y2,Y3,Y4,Y5,Y6

**1.5 HP
(1.1 kW)**

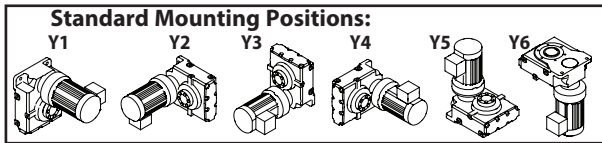

Dimension Pages:
Single Reduction 3.80-3.85
Double Reduction 3.86-3.91

Frequency	50 Hz	60 Hz
Input Speed	1450 RPM	1750 RPM
Number of Poles	4	

50Hz				60 Hz				Selection					
Output Speed (RPM)	Output Torque		Service Factor		Output Speed (RPM)	Output Torque		Service Factor		Base		VFD ^[1]	
	in-lbs	(N·m)	SF	AGMA Class		in-lbs	(N·m)	SF	AGMA Class	Motor Power Code	Frame Size		Ratio
3.98	21500	(2430)	0.77	-	4.81	17800	(2010)	0.93	-	1H	B612DB	364	
			1.45	II				1H	C614DB	364			
			1.53	II				1H	C614DC	364			
			2.66	III				1H	D616DB	364			
3.42	25000	(2830)	0.66	-	4.13	20700	(2340)	0.80	-	1H	B612DB	424	
			1.32	I				1H	C614DB	424			
			1.32	I				1H	C614DC	424			
			2.29	III				1H	D616DB	424			
			3.05	III				1H	E617DB	424			
			3.19	III				1H	E617DC	424			
2.90	29600	(3340)	0.56	-	3.50	24500	(2770)	0.67	-	1H	B612DB	501	
			1.12	I				1H	C614DB	501			
			1.45	II				1H	D616DA	501			
			1.94	II				1H	D616DB	501			
			2.70	III				1H	E617DB	501			
			2.70	III				1H	E617DC	501			
2.51	34100	(3860)	0.48	-	3.03	28300	(3200)	0.58	-	1H	B612DB	578	
			0.97	-				1H	C614DB	578			
			1.45	II				1H	D616DA	578			
			1.68	II				1H	D616DB	578			
			2.34	III				1H	E617DB	578			
2.12	40300	(4560)	0.82	-	2.56	33400	(3780)	0.99	-	1H	C614DB	683	
			1.42	II				1H	D616DA	683			
			1.42	II				1H	D616DB	683			
			1.98	II				1H	E617DB	683			
1.79	47800	(5400)	0.69	-	2.16	39600	(4470)	0.83	-	1H	C614DB	809	
			1.20	I				1H	D616DA	809			
			1.45	II				1H	E617DA	809			
			1.67	II				1H	E617DB	809			
1.52	56500	(6380)	0.58	-	1.83	46800	(5290)	0.71	-	1H	C614DB	956	
			1.01	I				1H	D616DA	956			
			1.41	II				1H	E617DA	956			
			1.41	II				1H	E617DB	956			
1.30	66000	(7460)	0.50	-	1.57	54700	(6180)	0.60	-	1H	C614DB	1117	
			0.87	-				1H	D616DA	1117			
			1.21	I				1H	E617DA	1117			

Notes: [1] Variable Frequency Drive (VFD) notes (see page 3.8 for Constant Torque Speed Ranges):
 (-) = For Inverter Operation, starting condition may require ambient temperature of 5° C or higher.
 (a) = Both AV and non-AV motors can be used for selection.

Cyclo® HBB

Selection
Tables

Double Reduction Selection Tables: Y1,Y2,Y3,Y4,Y5,Y6

1.5 HP
(1.1 kW)

Standard Mounting Positions:

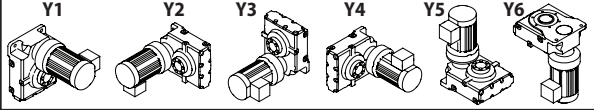

Dimension Pages:

Single Reduction 3.80-3.85
Double Reduction 3.86-3.91

Frequency	50 Hz	60 Hz
Input Speed	1450 RPM	1750 RPM
Number of Poles	4	

Output Speed (RPM)	50Hz				60 Hz				Selection			VFD ^[1]
	Output Torque		Service Factor		Output Torque		Service Factor		Base			
	in-lbs	(N·m)	SF	AGMA Class	in-lbs	(N·m)	SF	AGMA Class	Motor Power Code	Frame Size	Ratio	
1.10	78000	(8810)	0.42	-	1.33	64600	(7300)	0.51	-	1H	C614DB	1320
			0.73	-				1H	D616DA	1320		
			1.02	I				1H	E617DA	1320		
0.876	97900	(11100)	0.59	-	1.06	81100	(9160)	0.71	-	1H	D616DA	1656
			0.82	-				1H	E617DA	1656		
0.741	116000	(13100)	0.50	-	0.894	95800	(10800)	0.60	-	1H	D616DA	1957
			0.69	-				1H	E617DA	1957		
0.638	134000	(15200)	0.43	-	0.770	111000	(12600)	0.51	-	1H	D616DA	2272
			0.60	-				1H	E617DA	2272		
0.567	151000	(17100)	0.53	-	0.684	125000	(14200)	0.64	-	1H	E617DA	2559
0.493	174000	(19700)	0.46	-	0.595	144000	(16300)	0.55	-	1H	E617DA	2944

Cyclo® HBB

Selection
Tables

Notes: [1] Variable Frequency Drive (VFD) notes (see page 3.8 for Constant Torque Speed Ranges):
 (-) = For Inverter Operation, starting condition may require ambient temperature of 5° C or higher.
 (a) = Both AV and non-AV motors can be used for selection.

Double Reduction Selection Tables: Y1,Y2,Y3,Y4,Y5,Y6

**2 HP
(1.5 kW)**

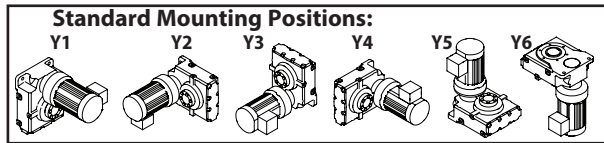

Dimension Pages:
Single Reduction 3.80-3.85
Double Reduction 3.86-3.91

Frequency	50 Hz	60 Hz
Input Speed	1450 RPM	1750 RPM
Number of Poles	4	

50Hz					60 Hz					Selection			
Output Speed (RPM)	Output Torque		Service Factor		Output Speed (RPM)	Output Torque		Service Factor		Motor Power Code	Base		VFD ^[1]
	in-lbs	(N·m)	SF	AGMA Class		in-lbs	(N·m)	SF	AGMA Class		Frame Size	Ratio	
3.98	29300	(3320)	0.56	-	4.81	24300	(2750)	0.68	-	2	B612DB	364	
			1.07	I				1.07	I		C614DB	364	
			1.13	I				1.36	I		C614DC	364	
			1.95	II				2.24	III		D616DB	364	
			1.95	II				2.36	III		D616DC	364	
			2.72	III				3.29	III		E617DC	364	
3.42	34100	(3860)	0.48	-	4.13	28300	(3200)	0.58	-	2	B612DB	424	
			0.97	-				1.07	I		C614DB	424	
			0.97	-				1.17	I		C614DC	424	
			1.68	II				2.02	III		D616DB	424	
			2.24	III				2.24	III		E617DB	424	
			2.34	III				2.83	III		E617DC	424	
2.90	40300	(4560)	0.82	-	3.50	33400	(3780)	0.99	-	2	C614DB	501	
			1.07	I				1.07	I		D616DA	501	
			1.42	II				1.71	II		D616DB	501	
			1.98	II				2.24	III		E617DB	501	
			1.98	II				2.39	III		E617DC	501	
2.51	46600	(5260)	0.71	-	3.03	38600	(4360)	0.86	-	2	C614DB	578	
			1.07	I				1.07	I		D616DA	578	
			1.23	I				1.48	II		D616DB	578	
			1.72	II				2.07	III		E617DB	578	
2.12	55000	(6220)	0.60	-	2.56	45600	(5150)	0.72	-	2	C614DB	683	
			1.04	I				1.07	I		D616DA	683	
			1.04	I				1.26	I		D616DB	683	
			1.45	II				1.75	II		E617DB	683	
1.79	65200	(7360)	0.51	-	2.16	54000	(6100)	0.61	-	2	C614DB	809	
			0.88	-				1.06	I		D616DA	809	
			1.07	I				1.07	I		E617DA	809	
			1.23	I				1.48	II		E617DB	809	
1.52	77000	(8700)	0.43	-	1.83	63800	(7210)	0.52	-	2	C614DB	956	
			0.74	-				0.90	-		D616DA	956	
			1.04	I				1.07	I		E617DA	956	
			1.04	I				1.25	I		E617DB	956	
1.30	90000	(10200)	0.64	-	1.57	74600	(8430)	0.77	-	2	D616DA	1117	
			0.89	-				1.07	I		E617DA	1117	
1.10	106000	(12000)	0.54	-	1.33	88100	(9960)	0.65	-	2	D616DA	1320	
			0.75	-				0.91	-		E617DA	1320	

Notes: [1] Variable Frequency Drive (VFD) notes (see page 3.8 for Constant Torque Speed Ranges):
 (-) = For Inverter Operation, starting condition may require ambient temperature of 5° C or higher.
 (a) = Both AV and non-AV motors can be used for selection.

Cyclo® HBB
Selection
Tables

Double Reduction Selection Tables: Y1,Y2,Y3,Y4,Y5,Y6

**2 HP
(1.5 kW)**

Standard Mounting Positions:

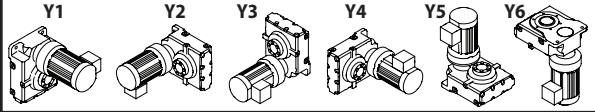

Dimension Pages:

Single Reduction 3.80-3.85
Double Reduction 3.86-3.91

Frequency	50 Hz	60 Hz
Input Speed	1450 RPM	1750 RPM
Number of Poles	4	

Output Speed (RPM)	50Hz				60 Hz				Selection			VFD ^[1]
	Output Torque		Service Factor		Output Speed (RPM)	Output Torque		Service Factor		Base		
	in·lbs	(N·m)	SF	AGMA Class		in·lbs	(N·m)	SF	AGMA Class	Motor Power Code	Frame Size	
0.876	133000 (15100)		0.43	-	1.06	111000 (12500)		0.52	-	2	D616DA	1656
			0.60	-				0.72	-	2	E617DA	1656
0.741	158000 (17800)		0.51	-	0.894	131000 (14800)		0.61	-	2	E617DA	1957
0.638	183000 (20700)		0.44	-	0.770	152000 (17100)		0.53	-	2	E617DA	2272

Cyclo® HBB

Selection
Tables

Notes: [1] Variable Frequency Drive (VFD) notes (see page 3.8 for Constant Torque Speed Ranges):
 (-) = For Inverter Operation, starting condition may require ambient temperature of 5° C or higher.
 (a) = Both AV and non-AV motors can be used for selection.

Double Reduction Selection Tables: Y1,Y2,Y3,Y4,Y5,Y6

**3 HP
(2.2 kW)**

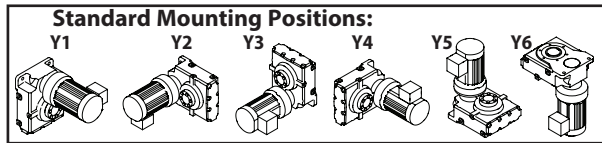

Dimension Pages:
Single Reduction 3.80-3.85
Double Reduction 3.86-3.91

Frequency	50 Hz	60 Hz
Input Speed	1450 RPM	1750 RPM
Number of Poles	4	

50Hz				60 Hz				Selection			VFD ^[1]	
Output Speed (RPM)	Output Torque		Service Factor		Output Speed (RPM)	Output Torque		Base		Ratio		
	in-lbs	(N·m)	SF	AGMA Class		in-lbs	(N·m)	SF	AGMA Class			Motor Power Code
3.98	43000	(4860)	0.73	-	4.81	35700	(4030)	0.73	-	3	C614DB	364
			0.77	-				3	C614DC	364		
			1.33	I				3	D616DB	364		
			1.33	I				3	D616DC	364		
			1.86	II				3	E617DC	364		
3.42	50100	(5660)	0.66	-	4.13	41500	(4690)	0.73	-	3	C614DB	424
			0.66	-				3	C614DC	424		
			1.14	I				3	D616DB	424		
			1.53	II				3	E617DB	424		
			1.60	II				3	E617DC	424		
2.90	59200	(6690)	0.56	-	3.50	49000	(5540)	0.67	-	3	C614DB	501
			0.73	-				3	D616DA	501		
			0.97	-				3	D616DB	501		
			1.35	I				3	E617DB	501		
			1.35	I				3	E617DC	501		
2.51	68300	(7720)	0.48	-	3.03	56600	(6390)	0.58	-	3	C614DB	578
			0.73	-				3	D616DA	578		
			0.84	-				3	D616DB	578		
			1.17	I				3	E617DB	578		
2.12	80700	(9120)	0.71	-	2.56	66900	(7550)	0.73	-	3	D616DA	683
			0.71	-				3	D616DB	683		
			0.99	-				3	E617DB	683		
1.79	95600	(10800)	0.60	-	2.16	79200	(8950)	0.72	-	3	D616DA	809
			0.73	-				3	E617DA	809		
			0.84	-				3	E617DB	809		
1.52	113000	(12800)	0.51	-	1.83	93600	(10600)	0.61	-	3	D616DA	956
			0.71	-				3	E617DA	956		
			0.71	-				3	E617DB	956		
1.30	132000	(14900)	0.43	-	1.57	109000	(12400)	0.52	-	3	D616DA	1117
			0.61	-				3	E617DA	1117		
1.10	156000	(17600)	0.51	-	1.33	129000	(14600)	0.62	-	3	E617DA	1320

Cyclo® HBB

Selection
Tables

Notes: [1] Variable Frequency Drive (VFD) notes (see page 3.8 for Constant Torque Speed Ranges):
 (-) = For Inverter Operation, starting condition may require ambient temperature of 5° C or higher.
 (a) = Both AV and non-AV motors can be used for selection.

Double Reduction Selection Tables: Y1,Y2,Y3,Y4,Y5,Y6

**5 HP
(3.7 kW)**

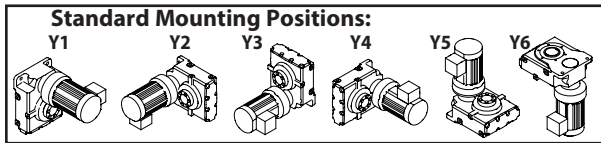

Dimension Pages:
Single Reduction 3.80-3.85
Double Reduction 3.86-3.91

Frequency	50 Hz	60 Hz
Input Speed	1450 RPM	1750 RPM
Number of Poles	4	

50Hz					60 Hz					Selection			
Output Speed (RPM)	Output Torque		Service Factor		Output Speed (RPM)	Output Torque		Service Factor		Motor Power Code	Base		VFD ^[1]
	in·lbs	(N·m)	SF	AGMA Class		in·lbs	(N·m)	SF	AGMA Class		Frame Size	Ratio	
3.98	72400	(8180)	0.79	-	4.81	60000	(6780)	0.95	-	5	D616DC	364	
			1.10	I				5	E617DC	364			
3.42	84200	(9520)	0.68	-	4.13	69800	(7880)	0.82	-	5	D616DC	424	
			0.95	-				5	E617DC	424			
2.90	99500	(11200)	0.58	-	3.50	82500	(9320)	0.69	-	5	D616DC	501	
			0.80	-				5	E617DC	501			
2.51	115000	(13000)	0.50	-	3.03	95200	(10800)	0.60	-	5	D616DC	578	
			0.70	-				5	E617DC	578			
2.12	136000	(15300)	0.42	-	2.56	112000	(12700)	0.51	-	5	D616DC	683	
			0.59	-				5	E617DC	683			
1.79	161000	(18200)	0.50	-	2.16	133000	(15100)	0.60	-	5	E617DC	809	
1.52	190000	(21500)	0.42	-	1.83	157000	(17800)	0.51	-	5	E617DC	956	

Cyclo® HBB

Selection
Tables

Notes: [1] Variable Frequency Drive (VFD) notes (see page 3.8 for Constant Torque Speed Ranges):
 (-) = For Inverter Operation, starting condition may require ambient temperature of 5° C or higher.
 (a) = Both AV and non-AV motors can be used for selection.

Double Reduction Selection Tables: Y1,Y2,Y3,Y4,Y5,Y6

**7.5 HP
(5.5 kW)**

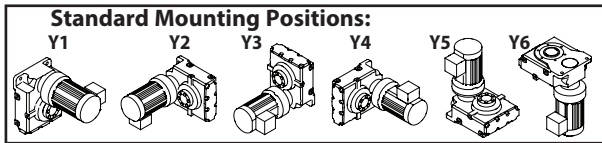

Dimension Pages:

Single Reduction	3.80-3.85
Double Reduction	3.86-3.91

Frequency	50 Hz	60 Hz
Input Speed	1450 RPM	1750 RPM
Number of Poles	4	

50Hz				60 Hz				Selection				
Output Speed (RPM)	Output Torque		Service Factor		Output Speed (RPM)	Output Torque		Base			VFD ^[1]	
	in·lbs	(N·m)	SF	AGMA Class		in·lbs	(N·m)	SF	AGMA Class	Motor Power Code		Frame Size
3.98	108000 (12200)		0.53	-	4.81	89200 (10100)		0.64	-	8	D616DC	364
			0.74	-				0.90	-	8	E617DC	364
3.42	125000 (14100)		0.46	-	4.13	104000 (11700)		0.55	-	8	D616DC	424
			0.64	-				0.77	-	8	E617DC	424
2.90	148000 (16700)		0.54	-	3.50	123000 (13900)		0.65	-	8	E617DC	501
2.51	171000 (19300)		0.47	-	3.03	141000 (16000)		0.57	-	8	E617DC	578

Cyclo® HBB

Selection
Tables

Notes: [1] Variable Frequency Drive (VFD) notes (see page 3.8 for Constant Torque Speed Ranges):
 (-) = For Inverter Operation, starting condition may require ambient temperature of 5° C or higher.
 (a) = Both AV and non-AV motors can be used for selection.

Dimensions

Single Reduction EHYM-Z6090Y~A6105Y

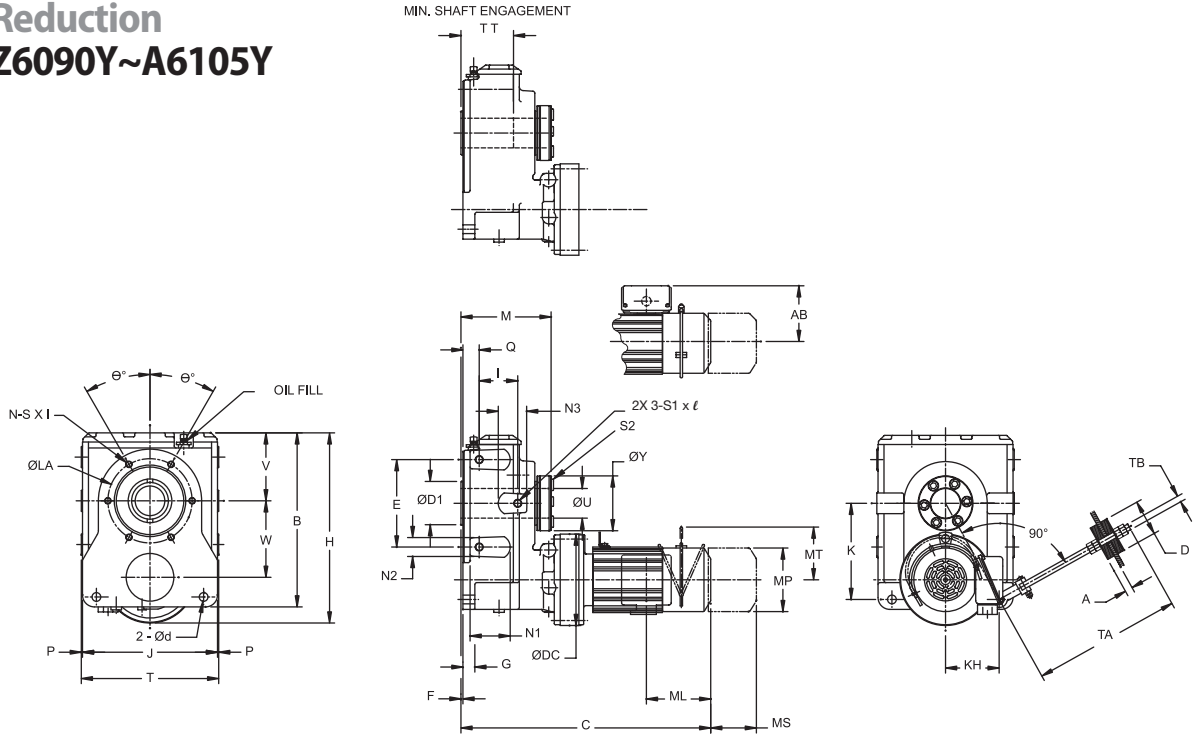

All dimensions are in inches (mm).

Model	B	E	F	G	H	I	J	K	M	P	Q	T	TT	ØU	
														Max (Std)	Min
Z609	11.00 (279.5)	5.51 (140)	0.20 (5)	0.79 (20)	11.87 (301)	2.20 (56)	8.31 (211)	6.18 (157)	6.06 (154)	0.12 (3)	1.06 (27)	8.54 (217)	4.43 (113)	1-7/16 (36.5)	1-3/16 (30.2)
A610	11.83 (300.5)	5.91 (150)			12.70 (323)	2.60 (66)	9.17 (233)	6.44 (163.5)	6.61 (168)		1.14 (29)	9.41 (239)	4.96 (126)	2-3/16 (55.6)	1-11/16 (42.9)

Model	V	W	ØY	Ød	ØD1	ØDC	KH	N1	N2	N3	S2	TA	A	D	TB
Z609	4.23 (107.5)	4.69 (119)	3.23 (82)	0.55 (14)	2.56 (65)	5.91 (150)	3.54 (90)	1.02 (26)	1.02 (26)	-	M10	17.50 (445)	0.63 (16)	2.36 (60)	M20
A610	4.61 (117)	5.14 (131)	4.09 (104)	0.71 (18)	3.35 (85)		3.74 (95)	1.10 (28)	1.10 (28)		M12				

Cyclo® HBB

Dimensions

Dimensions

Single Reduction EHYM-Z6090Y~A6105Y (cont.)

All dimensions are in inches (mm)

Frames	HPxP (kW x P)	Model	Without Brake					With Brake										
			C	AB	ML	MP ^[1]	Wt. lb (kg)	C	AB	ML	MP ^[1]	MS	MT	Wt. lb (kg)				
Z6090 Z6095	1/8 x 4 (0.1 x 4)	EHYM01-Z6095Y	12.01 (305)	4.63 (118)	1.38 (35)	ø4.88 (ø124)	68 (31)	13.39 (340)	4.63 (118)	3.58 (91)	ø4.88 (ø124)	1.93 (49)	-	71 (32)				
	1/4 x 4 (0.2 x 4)	EHYM02-Z6095Y	13.66 (347)		70 (32)		14.92 (379)	2.40 (61)				73 (33)						
	1/3 x 4 (0.25 x 4)	EHYM03-Z6095Y	14.45 (367)		73 (33)		15.71 (399)	2.40 (61)				76 (35)						
	1/2 x 4 (0.4 x 4)	EHYM05-Z6095Y	16.06 (408)		5.67 (144)		3.82 (97)	ø5.94 (ø151)				78 (35)		17.76 (451)	5.67 (144)	5.51 (140)	ø5.94 (ø151)	3.66 (93)
	3/4 x 4 (0.55 x 4)	EHYM08-Z6095Y	16.06 (408)	4.63 (118)	2.32 (59)	ø4.88 (ø124)	70 (32)	14.92 (379)	4.63 (118)	3.58 (91)	ø4.88 (ø124)	2.40 (61)	-	73 (33)				
	1/8 x 4 (0.1 x 4)	EHYM01-Z6095Y-AV	13.66 (347)				73 (33)	15.71 (399)				2.40 (61)		76 (35)				
	1/4 x 4 (0.2 x 4)	EHYM02-Z6095Y-AV	14.45 (367)				80 (37)	17.76 (451)				5.67 (144)		5.51 (140)	ø5.94 (ø151)	3.66 (93)	3.94 (100)	86 (39)
	1/3 x 4 (0.25 x 4)	EHYM03-Z6095Y-AV	16.06 (408)				5.86 (149)	3.94 (100)				ø5.94 (ø151)		88 (40)	19.80 (503)	5.86 (149)	6.38 (162)	ø6.30 (ø160)
	1/2 x 4 (0.4 x 4)	EHYM05-Z6095Y-AV	17.36 (441)	5.98 (152)	3.82 (97)	ø4.88 (ø124)	93 (43)	20.30 (516)	5.98 (152)	6.32 (161)	6.22 (158)	4.80 (122)	4.80 (122)	4.25 (108)	103 (47)			
	3/4 x 4 (0.55 x 4)	EHYM08-Z6095Y-AV	17.80 (452)				101 (46)	21.59 (549)				6.16 (156)		6.56 (167)	6.57 (167)	5.04 (128)	4.61 (117)	112 (51)
	1 x 4 (0.75 x 4)	EHYM1-Z6095Y-EP	18.86 (479)				104 (47)	112 (51)				115 (53)						
	1.5 x 4 (1.1 x 4)	EHYM1H-Z6095Y-EP	18.86 (479)				6.16 (156)	112 (51)				115 (53)						
	2 x 4 (1.5 x 4)	EHYM2-Z6095Y-EP	18.86 (479)	6.16 (156)	112 (51)	115 (53)												

Frames	HPxP (kW x P)	Model	Without Brake					With Brake													
			C	AB	ML	MP ^[1]	Wt	C	AB	ML	MP ^[1]	MS	MT	Wt. lb (kg)							
A6100, A6105	1/4 x 4 (0.2 x 4)	EHYM02-A6105Y	14.80 (376)	4.63 (118)	2.32 (59)	ø4.88 (ø124)	93 (42)	16.06 (408)	4.63 (118)	3.58 (91)	ø4.88 (ø124)	2.40 (61)	-	96 (44)							
	1/3 x 4 (0.25 x 4)	EHYM03-A6105Y	15.59 (396)				96 (44)	16.85 (428)				2.40 (61)		99 (45)							
	1/2 x 4 (0.4 x 4)	EHYM05-A6105Y	17.20 (437)				5.67 (144)	3.82 (97)				ø6.30 (ø160)		101 (46)	18.90 (480)	5.67 (144)	5.51 (140)	ø5.94 (ø151)	3.66 (93)	3.94 (100)	106 (49)
	3/4 x 4 (0.55 x 4)	EHYM08-A6105Y	17.20 (437)				4.63 (118)	2.32 (59)				ø4.88 (ø124)		96 (44)	16.85 (428)	4.63 (118)	3.58 (91)	ø4.88 (ø124)	2.40 (61)	-	99 (45)
	1/4 x 4 (0.2 x 4)	EHYM02-A6105Y-AV	15.59 (396)	103 (47)	18.90 (480)	5.67 (144)			5.51 (140)	ø5.94 (ø151)	3.66 (93)		3.94 (100)	109 (50)							
	1/3 x 4 (0.25 x 4)	EHYM03-A6105Y-AV	17.20 (437)	5.86 (149)	3.94 (100)	ø5.94 (ø151)			111 (51)	20.94 (532)	5.86 (149)		6.38 (162)	ø6.30 (ø160)	4.53 (115)				4.29 (109)		122 (56)
	1/2 x 4 (0.4 x 4)	EHYM05-A6105Y-AV	18.50 (470)	5.98 (152)	3.82 (97)	ø4.88 (ø124)			116 (53)	21.44 (545)	5.98 (152)		6.32 (161)	6.22 (158)	4.80 (122)				4.80 (122)		4.25 (108)
	3/4 x 4 (0.55 x 4)	EHYM08-A6105Y-AV	18.94 (481)				124 (56)	22.74 (578)	6.16 (156)	6.56 (167)		6.57 (167)			5.04 (128)	4.61 (117)	135 (62)				
	1 x 4 (0.75 x 4)	EHYM1-A6105Y-EP	20.00 (508)				127 (58)	138 (63)	138 (63)												
	1.5 x 4 (1.1 x 4)	EHYM1H-A6105Y-EP	20.00 (508)				6.16 (156)	135 (62)	138 (63)												
	2 x 4 (1.5 x 4)	EHYM2-A6105Y-EP	20.83 (529)	6.71 (170)	4.53 (115)	7.24 (184)	143 (65)	23.90 (607)	6.71 (170)	7.60 (193)	7.24 (184)	5.43 (138)	5.04 (128)	159 (73)							
	3 x 4 (2.2 x 4)	EHYM3-A6105Y-EP	20.83 (529)	6.71 (170)	4.53 (115)	7.24 (184)	143 (65)	23.90 (607)	6.71 (170)	7.60 (193)	7.24 (184)	5.43 (138)	5.04 (128)	159 (73)							

Notes [1]: DM Dimension Symbol ø = Round Fan Cover
DM Dimension Symbol = Square Fan Cover

Dimensions

Single Reduction EHYM-B6120Y~C6145Y

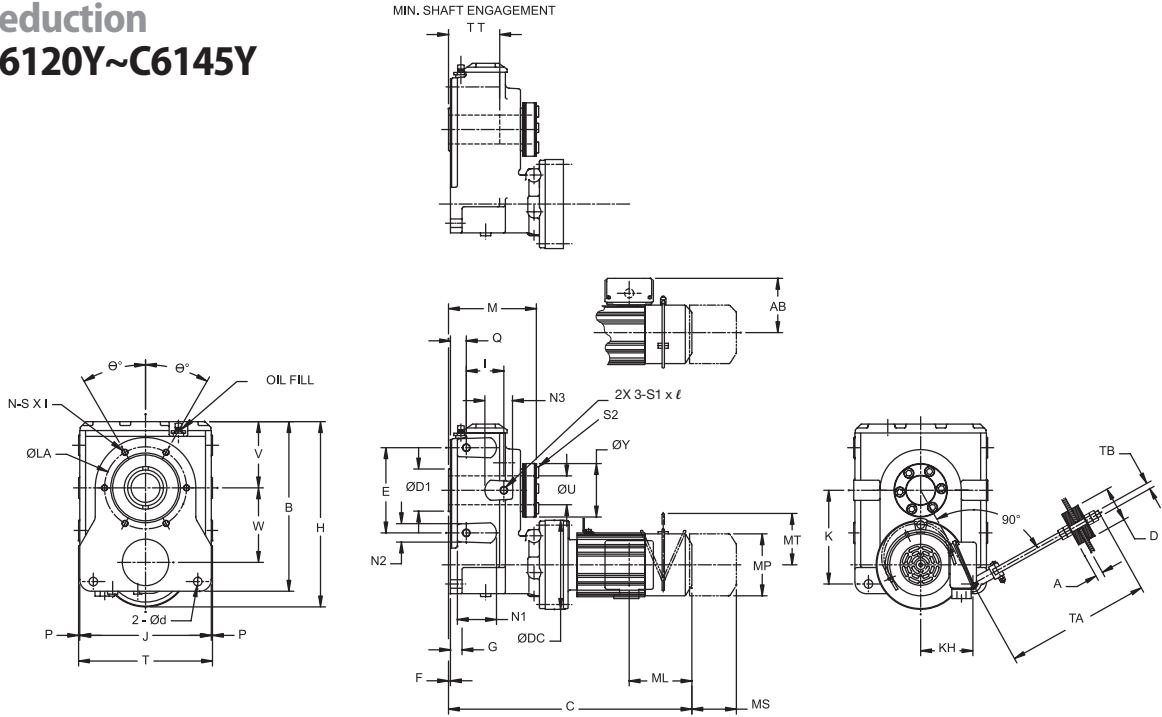

All dimensions are in inches (mm).

Model	B	E	F	G	H	I	J	K	M	P	Q	T	TT	ØU	
														Max (Std)	Min
B612	14.45 (367)	7.48 (190)	0.20 (5)	0.98 (35)	16.10 (409)	3.39 (86)	11.42 (290)	7.97 (202.5)	7.64 (194)	0.12 (3)	1.22 (31)	11.65 (296)	5.63 (143)	2-7/16 (61.9)	1-15/16 (49.2)
C614	17.24 (438)	8.66 (220)		1.18 (30)	18.84 (479)	3.82 (97)	13.39 (340)	9.53 (242)	9.17 (233)		1.61 (41)	13.62 (346)	7.32 (186)	2-15/16 (74.6)	2-3/16 (55.6)

Model	V	W	ØY	Ød	ØD1	ØDC	KH	N1	N2	N3	S2	TA	A	D	TB
B612	5.69 (144.5)	6.40 (163)	4.49 (114)	0.71 (18)	3.94 (100)	8.03 (204)	4.33 (110)	1.34 (34)	1.26 (32)	-	M12	17.87 (454)	0.63 (16)	2.36 (60)	M20
C614	6.73 (171)	7.58 (193)	5.43 (138)	0.87 (22)	4.33 (110)	9.06 (230)	5.31 (135)	3.98 (101)	2.05 (52)	2.83 (72)	M16	18.37 (467)	0.75 (19)	3.54 (90)	M24

Cyclo® HBB

Dimensions

Dimensions

Single Reduction EHYM-B6120Y~C6145Y (cont.)

All dimensions are in inches (mm).

Frames	HPxP (kW x P)	Model	Without Brake					With Brake						
			C	AB	ML	MP ^[1]	Wt	C	AB	ML	MP ^[1]	MS	MT	Wt. lb (kg)
B6120, B6125	1/2 x 4 (0.4 x 4)	EHYM05-B6125Y	17.07 (434)	4.63 (118)	2.32 (59)	ø4.88 (ø124)	165 (75)	18.33 (466)	4.63 (118)	3.58 (91)	ø4.88 (ø124)	2.40 (61)	-	168 (77)
	3/4 x 4 (0.55 x 4)	EHYM08-B6125Y	18.48 (470)	5.67 (144)	3.82 (97)	ø5.94 (ø151)	170 (77)	20.18 (513)	5.67 (144)	5.51 (140)	ø5.94 (ø151)	3.66 (93)	3.94 (100)	175 (80)
	1/2 x 4 (0.4 x 4)	EHYM05-B6125Y-AV					172 (78)							178 (81)
	3/4 x 4 (0.55 x 4)	EHYM08-B6125Y-AV	19.78 (503)	5.86 (149)	3.94 (100)	ø6.30 (ø160)	178 (81)	22.22 (565)	5.86 (149)	6.38 (162)	ø6.30 (ø160)	4.53 (115)	4.29 (109)	189 (86)
	1 x 4 (0.75 x 4)	EHYM1-B6125Y-EP	20.22 (514)	5.98 (152)	3.82 (97)	6.22 (158)	183 (83)	22.72 (577)	5.98 (152)	6.32 (161)	6.22 (158)	4.80 (122)	4.25 (108)	193 (88)
	1.5 x 4 (1.1 x 4)	EHYM1H-B6125Y-EP	21.28 (541)	6.16 (156)	3.82 (97)	6.57 (167)	190 (86)	24.02 (610)	6.16 (156)	6.56 (167)	6.57 (167)	5.04 (128)	4.61 (117)	201 (92)
	2 x 4 (1.5 x 4)	EHYM2-B6125Y-EP					193 (88)							193 (88)
	3 x 4 (2.2 x 4)	EHYM3-B6125Y-EP	20.69 (526)	6.71 (170)	4.53 (115)	7.24 (184)	206 (94)	23.76 (604)	6.71 (170)	7.60 (193)	7.24 (184)	5.43 (138)	5.04 (128)	222 (101)
	5 x 4 (3.7 x 4)	EHYM5-B6125Y-EP	22.15 (563)	7.34 (186)	4.65 (118)	8.74 (222)	231 (105)	25.71 (653)	7.34 (186)	8.21 (209)	8.74 (222)	6.02 (153)	6.30 (160)	255 (116)
	7.5 x 4 (5.5 x 4)	EHYM8-B6125Y-EP	23.84 (606)				265 (120)	265 (120)						265 (120)
10 x 4 (7.5 x 4)	EHYM10-B6125Y-EP	25.57 (650)	9.04 (230)	5.43 (138)	10.24 (260)	293 (133)	29.70 (755)	9.04 (230)	9.57 (243)	10.24 (260)	7.44 (189)	7.32 (186)	337 (153)	

Frames	HPxP (kW x P)	Model	Without Brake					With Brake						
			C	AB	ML	MP ^[1]	Wt	C	AB	ML	MP ^[1]	MS	MT	Wt. lb (kg)
C6140, C6145	3/4 x 4 (0.55 x 4)	EHYM08-C6145Y	21.00 (534)	5.67 (144)	3.82 (97)	ø5.94 (ø151)	272 (124)	22.70 (577)	5.67 (144)	5.51 (140)	ø5.94 (ø151)	3.66 (93)	3.94 (100)	278 (126)
	3/4 x 4 (0.55 x 4)	EHYM08-C6145Y-AV	22.30 (567)	5.86 (149)	3.94 (100)		281 (128)	24.74 (629)	5.86 (149)	6.38 (162)	ø6.30 (ø160)	4.53 (115)	4.29 (109)	292 (133)
	1 x 4 (0.75 x 4)	EHYM1-C6145Y-EP	22.74 (578)	5.98 (152)	3.82 (97)	6.22 (158)	285 (130)	25.24 (641)	5.98 (152)	6.32 (161)	6.22 (158)	4.80 (122)	4.25 (108)	295 (134)
	1.5 x 4 (1.1 x 4)	EHYM1H-C6145Y-EP	23.80 (605)	6.16 (156)		6.57 (167)	292 (133)	26.54 (674)	6.16 (156)	6.56 (167)	6.57 (167)	5.04 (128)	4.61 (117)	304 (138)
	2 x 4 (1.5 x 4)	EHYM2-C6145Y-EP			295 (134)	295 (134)	295 (134)	295 (134)	295 (134)	295 (134)	295 (134)	295 (134)	295 (134)	295 (134)
	3 x 4 (2.2 x 4)	EHYM3-C6145Y-EP	23.21 (590)	6.71 (170)	4.53 (115)	7.24 (184)	307 (139)	26.28 (668)	6.71 (170)	7.60 (193)	7.24 (184)	5.43 (138)	5.04 (128)	323 (147)
	5 x 4 (3.7 x 4)	EHYM5-C6145Y-EP	24.47 (622)	7.34 (186)	4.65 (118)	8.74 (222)	331 (150)	28.03 (712)	7.34 (186)	8.21 (209)	8.74 (222)	6.02 (153)	6.30 (160)	355 (161)
	7.5 x 4 (5.5 x 4)	EHYM8-C6145Y-EP	26.16 (665)				365 (166)	365 (166)						365 (166)
	10 x 4 (7.5 x 4)	EHYM10-C6145Y-EP	27.66 (703)	9.04 (230)	5.43 (138)	10.24 (260)	392 (178)	31.79 (808)	9.04 (230)	9.57 (243)	10.24 (260)	7.44 (189)	7.32 (186)	436 (198)
	15 x 4 (11 x 4)	EHYM15-C6145Y-EP	30.10 (765)				404 (184)	404 (184)						404 (184)
20 x 4 (15 x 4)	EHYM20-C6145Y-EP	32.54 (827)	10.26 (261)	7.01 (178)	ø12.49 (ø317)	485 (220)	37.83 (961)	10.26 (261)	12.30 (313)	ø12.61 (ø320)	9.53 (242)	-	571 (259)	

Notes [1]: DM Dimension Symbol ø = Round Fan Cover
DM Dimension Symbol = Square Fan Cover

Dimensions

Single Reduction EHYM-D6160Y~E6175Y

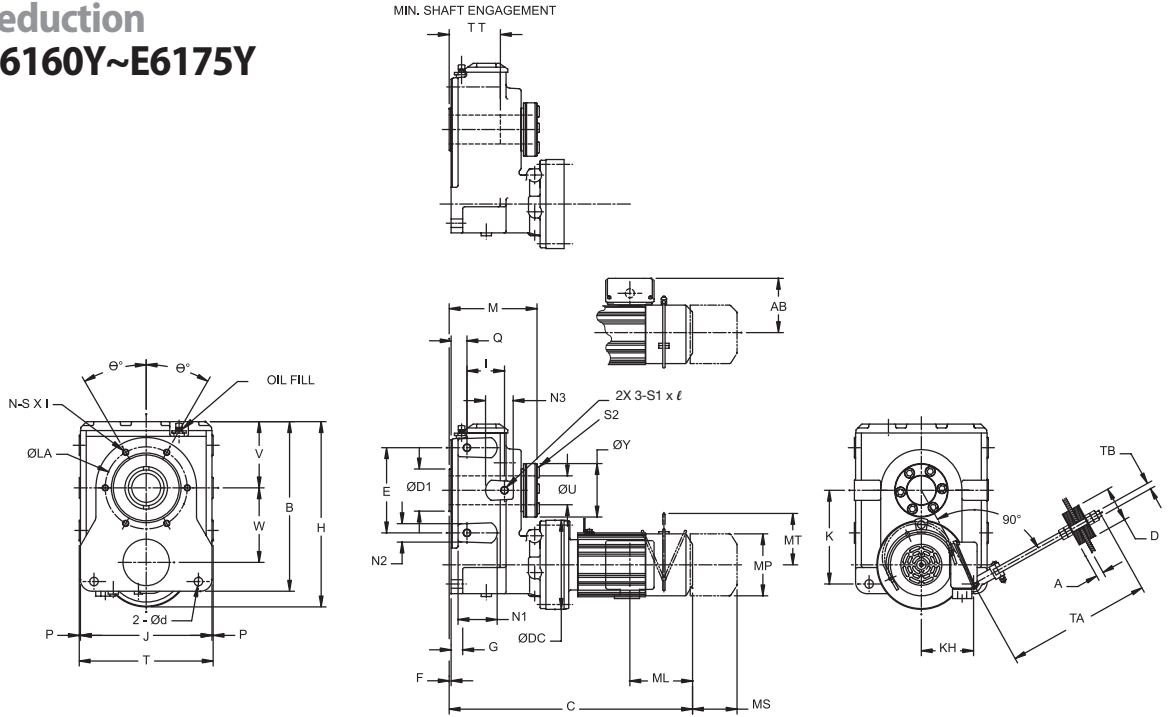

All dimensions are in inches.

Model	B	E	F	G	H	I	J	K	M	P	Q	T	TT	ØU	
														Max (Std)	Min
D616	21.22 (539)	9.84 (250)	0.28 (7)	1.38 (35)	23.94 (608)	4.49 (114)	16.77 (426)	11.54 (293)	10.20 (259)	0.20 (5)	1.77 (45)	17.17 (436)	8.03 (204)	3-7/16 (87.3)	2-7/16 (65.1)
E617	24.02 (610)	11.81 (300)		1.77 (45)	26.85 (682)	5.00 (127)	18.90 (480)	13.07 (332)	10.98 (279)		1.97 (50)	19.29 (490)	8.82 (224)	3-15/16 (100)	2-15/16 (74.6)

Model	V	W	ØY	Ød	ØD1	ØDC	KH	N1	N2	N3	S2	TA	A	D	TB
D616	8.43 (214)	9.61 (244)	5.98 (152)	1.02 (26)	5.12 (130)	11.81 (300)	6.38 (162)	3.62 (92)	2.36 (60)	3.62 (92)	M16	19.50 (495)	0.75 (19)	3.54 (90)	M24
E617	9.45 (240)	10.71 (272)	6.69 (170)	1.30 (33)	5.91 (150)	13.39 (340)	7.09 (180)	3.82 (97)	2.44 (62)	3.94 (100)		20.25 (514)			

Cyclo® HBB

Dimensions

Dimensions

Single Reduction EHYM-D6160Y~E6175Y

All dimensions are in inches (mm)

Frames	HPxP (kW x P)	Model	Without Brake					With Brake						
			C	AB	ML	MP ^[1]	Wt	C	AB	ML	MP ^[1]	MS	MT	Wt. lb (kg)
D6160, D6165	1 x 4 (0.75 x 4)	EHYM1-D6165Y-EP	23.29 (592)	5.98 (152)	3.82 (97)	6.22 (158)	482 (219)	25.79 (655)	5.98 (152)	6.32 (161)	6.22 (158)	4.80 (122)	4.25 (108)	492 (224)
	1.5 x 4 (1.1 x 4)	EHYM1H-D6165Y-EP	24.35 (619)	6.16 (156)		6.57 (167)	490 (222)	27.09 (688)	6.16 (156)	6.56 (167)	6.57 (167)	5.04 (128)	4.61 (117)	501 (228)
	2 x 4 (1.5 x 4)	EHYM2-D6165Y-EP				493 (224)								504 (229)
	3 x 4 (2.2 x 4)	EHYM3-D6165Y-EP	24.09 (612)	6.71 (170)	4.53 (115)	7.24 (184)	503 (228)	27.17 (690)	6.71 (170)	7.60 (193)	7.24 (184)	5.43 (138)	5.04 (128)	519 (236)
	5 x 4 (3.7 x 4)	EHYM5-D6165Y-EP	24.96 (634)	7.34 (186)	4.65 (118)	8.74 (222)	528 (240)	28.52 (725)	7.34 (186)	8.21 (209)	8.74 (222)	6.02 (153)	6.30 (160)	551 (250)
	7.5 x 4 (5.5 x 4)	EHYM8-D6165Y-EP	26.65 (677)				561 (255)	30.22 (768)						585 (266)
	10 x 4 (7.5 x 4)	EHYM10-D6165Y-EP	27.01 (686)	9.04 (230)	5.43 (138)	10.24 (260)	589 (268)	31.14 (791)	9.04 (230)	9.57 (243)	10.24 (260)	7.44 (189)	7.32 (186)	634 (288)
	15 x 4 (11 x 4)	EHYM15-D6165Y-EP	29.45 (748)				602 (273)	33.58 (853)						646 (293)
	20 x 4 (15 x 4)	EHYM20-D6165Y-EP	31.06 (789)	10.26 (261)	7.01 (178)	ø12.49 (ø317)	685 (311)	36.36 (924)	10.26 (261)	12.30 (313)	ø12.61 (ø320)	9.53 (242)	-	771 (350)
	25 x 4 (18.5 x 4)	EHYM25-D6165Y-EP	33.86 (860)	13.39 (340)	9.06 (230)	ø15.12 (ø384)	963 (437)	40.71 (1034)	13.39 (340)	15.91 (404)	ø15.28 (ø388)	12.13 (308)	-	1060 (481)
30 x 4 (22 x 4)	EHYM30-D6165Y-EP													

Frames	HPxP (kW x P)	Model	Without Brake					With Brake						
			C	AB	ML	MP ^[1]	Wt	C	AB	ML	MP ^[1]	MS	MT	Wt. lb (kg)
E6170, E6175	3 x 4 (2.2 x 4)	EHYM3-E6175Y-EP	27.20 (691)	6.71 (170)	4.53 (115)	7.24 (184)	675 (306)	30.28 (769)	6.71 (170)	7.60 (193)	7.24 (184)	5.43 (138)	5.04 (128)	692 (314)
	5 x 4 (3.7 x 4)	EHYM5-E6175Y-EP	28.27 (718)	7.34 (186)	4.65 (118)	8.74 (222)	699 (317)	31.83 (809)	7.34 (186)	8.21 (209)	8.74 (222)	6.02 (153)	6.30 (160)	722 (328)
	7.5 x 4 (5.5 x 4)	EHYM8-E6175Y-EP	29.96 (761)				733 (333)	33.52 (852)						756 (343)
	10 x 4 (7.5 x 4)	EHYM10-E6175Y-EP	30.79 (782)	9.04 (230)	5.43 (138)	10.24 (260)	761 (346)	34.92 (887)	9.04 (230)	9.57 (243)	10.24 (260)	7.44 (189)	7.32 (186)	806 (366)
	15 x 4 (11 x 4)	EHYM15-E6175Y-EP	33.23 (844)				774 (351)	37.36 (949)						818 (371)
	20 x 4 (15 x 4)	EHYM20-E6175Y-EP	35.94 (913)	10.26 (261)	7.01 (178)	ø12.49 (ø317)	855 (388)	41.24 (1048)	10.26 (261)	12.30 (313)	ø12.61 (ø320)	9.53 (242)	-	941 (427)
	25 x 4 (18.5 x 4)	EHYM25-E6175Y-EP	40.12 (1019)	13.39 (340)	9.06 (230)	ø15.12 (ø384)	1134 (515)	46.97 (1193)	13.39 (340)	15.91 (404)	ø15.28 (ø388)	12.13 (308)	-	1231 (559)
	30 x 4 (22 x 4)	EHYM30-E6175Y-EP												
	40 x 4 (30 x 4)	EHYM40-E6175Y-EP	45.00 (1143)				1247 (566)	51.85 (1317)						1344 (610)

Notes [1]: DM Dimension Symbol ø = Round Fan Cover
DM Dimension Symbol = Square Fan Cover

Dimensions

Double Reduction EHYM-Z609DAY~A610DAY

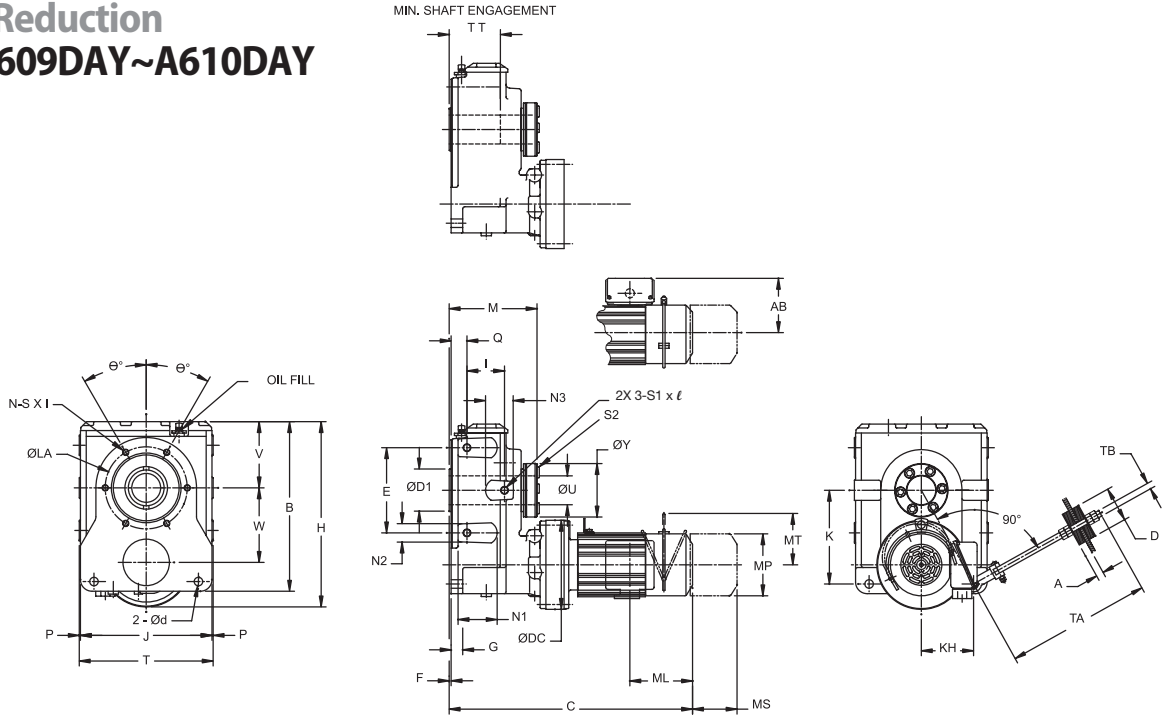

All dimensions are in inches (mm)

Model	B	E	F	G	H	I	J	K	M	P	Q	T	TT	ØU	
														Max (Std)	Min
Z609DA	11.00 (279.5)	5.51 (140)	0.20 (5)	0.79 (20)	11.87 (301)	2.20 (56)	8.31 (211)	6.18 (157)	6.06 (154)	0.12 (3)	1.06 (27)	8.54 (217)	4.43 (113)	1-7/16 (36.5)	1-3/16 (30.2)
A610DA	11.83 (300.5)	5.91 (150)			12.70 (323)	2.60 (66)	9.17 (233)	6.44 (163.5)	6.61 (168)		1.14 (29)	9.41 (239)	4.96 (126)	2-3/16 (55.6)	1-11/16 (42.9)

Model	V	W	ØY	Ød	ØD1	ØDC	KH	N1	N2	N3	S2	TA	A	D	TB
Z609DA	4.23 (107.4)	4.69 (119)	3.23 (82)	0.55 (14)	2.56 (65)	5.91 (150)	3.54 (90)	1.02 (26)	1.02 (26)	-	M10	17.50 (445)	0.63 (16)	2.36 (60)	M20
A610DA	4.61 (117)	5.14 (131)	4.09 (104)	0.71 (18)	3.35 (85)		3.74 (95)	1.10 (28)	1.10 (28)		M12				

Cyclo® HBB

Dimensions

Dimensions

Double Reduction EHYM-Z609DAY~A610DAY

All dimensions are in inches (mm)

Frames	HPxP (kW x P)	Model	Without Brake					With Brake							
			C	AB	ML	MP ^[1]	Wt	C	AB	ML	MP ^[1]	MS	MT	Wt. lb (kg)	
Z609DA	1/8 x 4 (0.1 x 4)	EHYM01-Z609DAY	13.92 (354)	4.63 (118)	1.38 (35)	ø4.69 (ø119)	72 (33)	15.30 (389)	4.63 (118)	3.58 (91)	ø4.88 (ø124)	1.93 (49)	-	75 (34)	
	1/4 x 4 (0.2 x 4)	EHYM02-Z609DAY	15.57 (396)		2.32 (59)	ø4.88 (ø124)	74 (34)	16.83 (428)				2.76 (70)		2.40 (61)	77 (35)
	1/3 x 4 (0.25 x 4)	EHYM03-Z609DAY													
	1/8 x 4 (0.1 x 4)	EHYM01-Z609DAY-AV													
	1/4 x 4 (0.2 x 4)	EHYM02-Z609DAY-AV													
	1/3 x 4 (0.25 x 4)	EHYM03-Z609DAY-AV	16.36 (416)		ø4.88 (ø124)	77 (35)	17.62 (448)	80 (36)							

Frames	HPxP (kW x P)	Model	Without Brake					With Brake							
			C	AB	ML	MP ^[1]	Wt	C	AB	ML	MP ^[1]	MS	MT	Wt. lb (kg)	
A610DA	1/8 x 4 (0.1 x 4)	EHYM01-A610DAY	15.06 (383)	4.63 (118)	1.38 (35)	ø4.69 (ø119)	97 (44)	16.44 (418)	4.63 (118)	3.58 (91)	ø4.88 (ø124)	1.93 (49)	-	100 (46)	
	1/4 x 4 (0.2 x 4)	EHYM02-A610DAY	16.71 (425)		2.32 (59)	ø4.88 (ø124)	99 (45)	17.97 (457)				2.76 (70)		2.40 (61)	102 (46)
	1/3 x 4 (0.25 x 4)	EHYM03-A610DAY													
	1/2 x 4 (0.4 x 4)	EHYM05-A610DAY													
	1/8 x 4 (0.1 x 4)	EHYM01-A610DAY-AV	16.71 (425)		ø4.69 (ø119)	99 (45)	17.97 (457)	102 (46)							
	1/4 x 4 (0.2 x 4)	EHYM02-A610DAY-AV	17.50 (445)		ø4.88 (ø124)	102 (46)	18.76 (477)	105 (48)							
	1/3 x 4 (0.25 x 4)	EHYM03-A610DAY-AV													

Notes [1]: DM Dimension Symbol ø = Round Fan Cover
DM Dimension Symbol = Square Fan Cover

Dimensions

Double Reduction EHYM-B612DAY~C614DBY

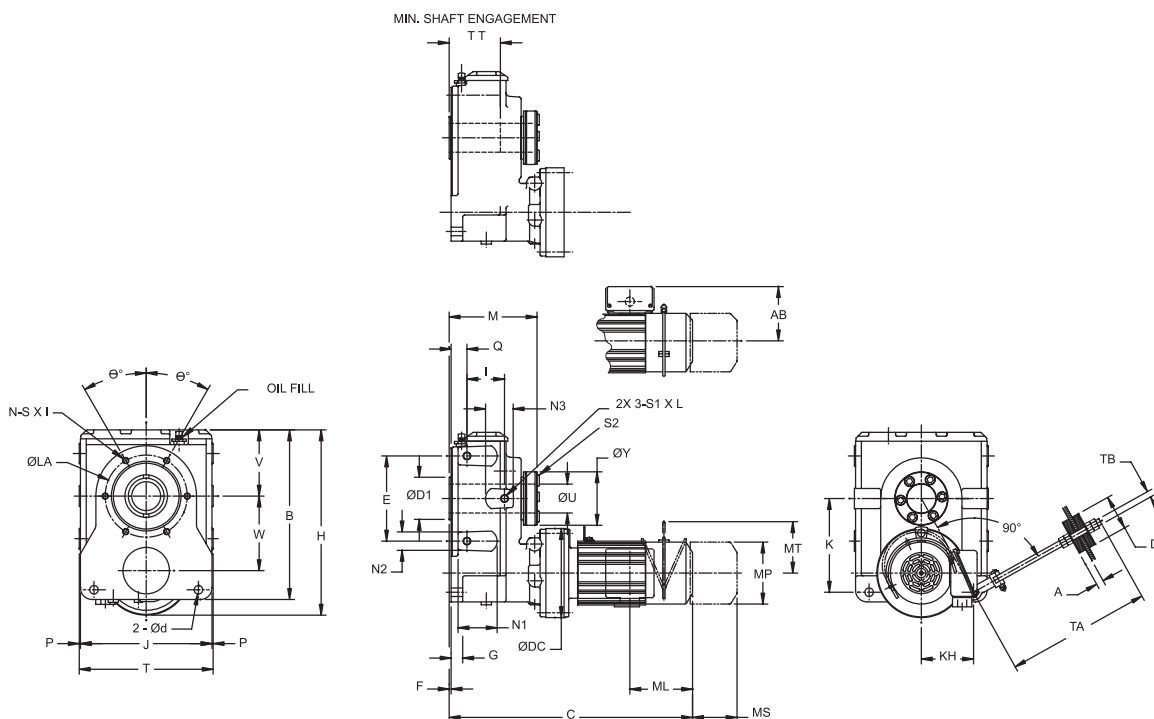

Cyclo® HBB

Dimensions

All dimensions are in inches (mm)

Model	B	E	F	G	H	I	J	K	M	P	Q	T	TT	ØU	
														Max (Std)	Min
B612DA	14.45 (367)	7.48 (190)	0.20 (5)	0.98 (25)	16.10 (409)	3.39 (86)	11.42 (290)	7.97 (202)	7.64 (194)	0.12 (3)	1.22 (31)	11.65 (296)	5.63 (143)	2-7/16 (61.9)	1-15/16 (49.2)
B612DB															
C614DA	17.24 (438)	8.66 (220)		1.18 (30)	18.84 (479)	3.82 (97)	13.39 (340)	9.53 (242)	9.17 (233)		1.61 (41)	13.62 (346)	7.32 (186)	2-15/16 (74.6)	2-3/16 (55.6)
C614DB															
C614DC															

Model	V	W	ØY	Ød	ØD1	ØDC	KH	N1	N2	N3	S2	TA	A	D	TB
B612DA	5.69 (144.5)	6.40 (163)	4.49 (114)	0.71 (18)	3.94 (100)	8.03 (204)	4.33 (110)	1.34 (32)	1.26 (32)	-	M12	17.87 (454)	0.63 (16)	2.36 (60)	M20
B612DB															
C614DA	6.73 (171)	7.58 (193)	5.43 (138)	0.87 (22)	4.33 (110)	9.06 (230)	5.31 (135)	3.98 (52)	2.05 (52)	2.83 (72)	M16	18.37 (467)	0.75 (19)	3.54 (90)	M24
C614DB															
C614DC															

Dimensions

Double Reduction EHYM-B612DAY~C614DBY

All dimensions are in inches (mm)

Frames	HPxP (kW x P)	Model	Without Brake					With Brake														
			C	AB	ML	MP ^[1]	Wt	C	AB	ML	MP ^[1]	MS	MT	Wt. lb (kg)								
B612DA	1/8 x 4 (0.1 x 4)	EHYM01-B612DAY	16.56 (421)	4.63 (118)	1.38 (35)	ø4.88 (ø124)	164 (75)	17.93 (456)	4.63 (118)	2.76 (70)	ø4.88 (ø124)	1.93 (49)	-	167 (76)								
	1/4 x 4 (0.2 x 4)	EHYM02-B612DAY	18.21 (463)												166 (76)	19.47 (495)	3.58 (91)	2.40 (61)				
	1/3 x 4 (0.25 x 4)	EHYM03-B612DAY	19.00 (483)												169 (77)	20.26 (515)						
	1/8 x 4 (0.1 x 4)	EHYM01-B612DAY-AV	18.21 (463)												166 (76)	19.47 (495)						
	1/4 x 4 (0.2 x 4)	EHYM02-B612DAY-AV	19.00 (483)												169 (77)	20.26 (515)						
	1/3 x 4 (0.25 x 4)	EHYM03-B612DAY-AV	171 (78)												19.92 (506)	2.40 (61)						
		EHYM03-B612DBY	18.66 (474)												19.92 (506)							
B612DB	1/2 x 4 (0.4 x 4)	EHYM05-B612DBY	19.45 (494)	4.63 (118)	2.32 (59)	ø5.94 (ø151)	174 (79)	20.71 (526)	4.63 (118)	3.58 (91)	ø4.88 (ø124)	2.40 (61)	-	177 (81)								
	3/4 x 4 (0.55 x 4)	EHYM08-B612DBY	21.06 (535)			5.67 (144)	3.82 (97)	ø6.30 (ø160)						179 (81)	22.76 (578)		5.67 (144)	5.51 (140)	ø5.94 (ø151)	3.66 (93)	3.94 (100)	184 (84)
	1/3 x 4 (0.25 x 4)	EHYM03-B612DBY-AV	19.45 (494)			4.63 (118)	2.32 (59)	ø4.88 (ø124)						174 (79)	20.71 (526)		4.63 (118)	3.58 (91)	ø4.88 (ø124)	2.40 (61)	-	177 (81)
	1/2 x 4 (0.4 x 4)	EHYM05-B612DBY-AV	21.06 (535)			5.67 (144)	3.82 (97)	ø5.94 (ø151)						181 (82)	22.76 (578)		5.67 (144)	5.51 (140)	ø5.94 (ø151)	3.66 (93)	3.94 (100)	187 (85)
	3/4 x 4 (0.55 x 4)	EHYM08-B612DBY-AV	22.36 (568)			5.86 (149)	3.94 (100)	ø5.94 (ø151)						189 (86)	24.80 (630)		5.86 (149)	6.38 (162)	ø6.30 (ø160)	4.53 (115)	4.29 (109)	200 (91)
	1 x 4 (0.75 x 4)	EHYM1-B612DBY-EP	22.80 (579)			5.98 (152)	3.82 (97)	ø6.22 (ø158)						194 (88)	25.30 (643)	5.98 (152)	6.32 (161)	ø6.22 (ø158)	4.80 (122)	4.25 (108)	204 (93)	

Frames	HPxP (kW x P)	Model	Without Brake					With Brake														
			C	AB	ML	MP ^[1]	Wt	C	AB	ML	MP ^[1]	MS	MT	Wt. lb (kg)								
C614DA	1/4 x 4 (0.2 x 4)	EHYM02-C614DAY	20.75 (527)	4.63 (118)	2.32 (59)	ø4.88 (ø124)	256 (116)	22.01 (559)	4.63 (118)	3.58 (91)	ø4.88 (ø124)	2.40 (61)	-	259 (118)								
	1/3 x 4 (0.25 x 4)	EHYM03-C614DAY													ø5.94 (ø151)	259 (118)	22.80 (579)					
	1/2 x 4 (0.4 x 4)	EHYM05-C614DAY	ø4.88 (ø124)			263 (120)	22.36 (568)															
	1/4 x 4 (0.2 x 4)	EHYM02-C614DAY-AV						21.54 (547)							259 (118)	22.80 (579)						
	1/3 x 4 (0.25 x 4)	EHYM03-C614DAY-AV						21.10 (536)							263 (120)	22.36 (568)						
C614DB	1/2 x 4 (0.4 x 4)	EHYM05-C614DBY	21.89 (556)	4.63 (118)	2.32 (59)	ø5.94 (ø151)	266 (121)	23.15 (588)	4.63 (118)	3.58 (91)	ø4.88 (ø124)	2.40 (61)	-	269 (122)								
	3/4 x 4 (0.55 x 4)	EHYM08-C614DBY	23.50 (597)			5.67 (144)	3.82 (97)	ø6.30 (ø160)						271 (123)	25.20 (640)	5.67 (144)	5.51 (140)	ø5.94 (ø151)	3.66 (93)	3.94 (100)	277 (126)	
	1/3 x 4 (0.25 x 4)	EHYM03-C614DBY-AV	21.89 (556)			4.63 (118)	2.32 (59)	ø4.88 (ø124)						266 (121)	23.15 (588)	4.63 (118)	3.58 (91)	ø4.88 (ø124)	2.40 (61)	-	269 (122)	
	1/2 x 4 (0.4 x 4)	EHYM05-C614DBY-AV	23.50 (597)			5.67 (144)	3.82 (97)	ø5.94 (ø151)						274 (124)	25.20 (640)	5.67 (144)	5.51 (140)	ø5.94 (ø151)	3.66 (93)	3.94 (100)	279 (127)	
	3/4 x 4 (0.55 x 4)	EHYM08-C614DBY-AV	24.80 (630)			5.86 (149)	3.94 (100)	ø5.94 (ø151)						282 (128)	27.24 (692)	5.86 (149)	6.38 (162)	ø6.30 (ø160)	4.53 (115)	4.29 (109)	293 (133)	
	1 x 4 (0.75 x 4)	EHYM1-C614DBY-EP	25.24 (641)			5.98 (152)	3.82 (97)	ø6.22 (ø158)						287 (130)	27.74 (705)	5.98 (152)	6.32 (161)	ø6.22 (ø158)	4.80 (122)	4.25 (108)	297 (135)	
		EHYM1H-C614DBY-EP	26.30 (668)			6.16 (156)	3.82 (97)	ø6.57 (ø167)						294 (134)	29.04 (738)	6.16 (156)	6.56 (167)	ø6.57 (ø167)	5.04 (128)	4.61 (117)	306 (139)	
	2 x 4 (1.5 x 4)	EHYM2-C614DBY-EP	297 (135)			297 (135)	297 (135)	297 (135)						297 (135)	297 (135)	297 (135)	297 (135)	297 (135)	297 (135)	297 (135)	297 (135)	309 (140)

Notes [1]: DM Dimension Symbol ø = Round Fan Cover
DM Dimension Symbol = Square Fan Cover

Dimensions

Double Reduction EHYM-D616DAY~E617DCY

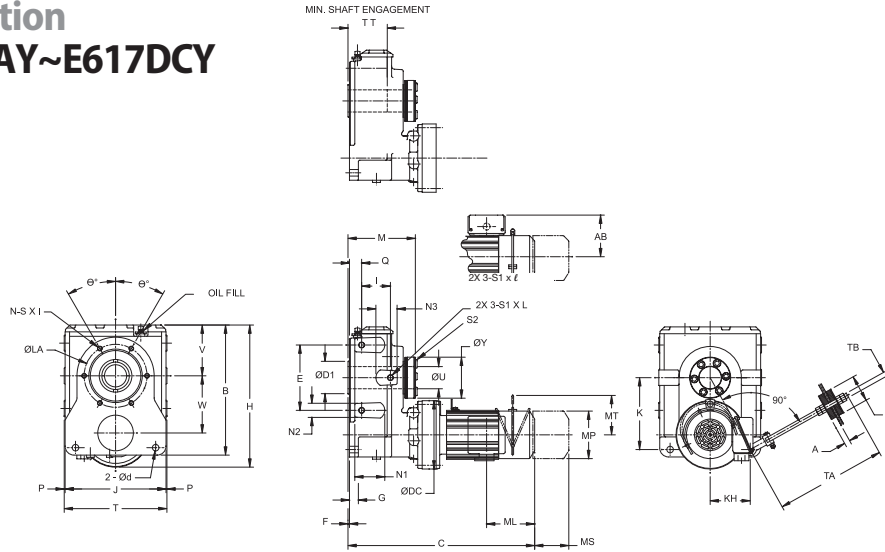

All dimensions are in inches (mm).

Model	B	E	F	G	H	I	J	K	M	P	Q	T	TT	ØU	
														Max (Std)	Min
D616DA	21.22 (539)	9.84 (250)	0.28 (7)	1.38 (35)	23.94 (608)	4.49 (114)	16.77 (426)	11.54 (293)	10.20 (259)	0.20 (5)	1.77 (45)	17.17 (436)	8.03 (204)	3-7/16 (87.3)	2-7/16 (61.9)
D616DB															
D616DC															
E617DA	24.02 (610)	11.81 (300)	1.77 (45)	26.85 (682)	5.00 (127)	18.90 (480)	13.07 (332)	10.98 (279)	1.97 (50)	19.29 (490)	8.82 (224)	3-15/16 (100)	2-15/16 (74.6)		
E617DB															
E617DC															

Model	V	W	ØY	Ød	ØD1	ØDC	KH	N1	N2	N3	S2	TA	A	D	TB
D616DA	8.43 (214)	9.61 (244)	5.98 (152)	1.02 (26)	5.12 (130)	11.81 (300)	6.38 (162)	3.62 (60)	2.36 (60)	3.62 (92)	M16	19.50 (495)	0.75 (19)	3.54 (90)	M24
D616DB															
D616DC															
E617DA	9.45 (240)	10.71 (272)	6.69 (170)	1.30 (33)	5.91 (150)	13.39 (340)	7.09 (180)	3.82 (62)	2.44 (62)	3.94 (100)	20.25 (514)				
E617DB															
E617DC															

Cyclo® HBB
Dimensions

Dimensions

Double Reduction EHYM-D616DAY~E617DCY

All dimensions are in inches (mm)

Frames	HPxP (kW x P)	Model	Without Brake					With Brake						
			C	AB	ML	MP ^[1]	Wt	C	AB	ML	MP ^[1]	MS	MT	Wt. lb (kg)
D616DA	1/2 x 4 (0.4 x 4)	EHYM05-D616DAY	24.04 (611)	4.63 (118)	2.32 (59)	ø5.94 (ø151)	470 (213)	25.30 (643)	4.63 (118)	3.58 (91)	ø4.88 (ø124)	2.40 (61)	-	473 (215)
	3/4 x 4 (0.55 x 4)	EHYM08-D616DAY	25.65 (652)	5.67 (144)	3.82 (97)		474 (215)	27.34 (695)	5.67 (144)	5.51 (140)	ø5.94 (ø151)	3.66 (93)	3.94 (100)	480 (218)
	1/2 x 4 (0.4 x 4)	EHYM05-D616DAY-AV				477 (217)	483 (219)							
	3/4 x 4 (0.55 x 4)	EHYM08-D616DAY-AV	26.95 (685)	5.86 (149)	3.94 (100)	ø5.94 (ø151)	485 (220)	29.39 (747)	5.86 (149)	6.38 (162)	ø6.30 (ø160)	4.53 (115)	4.29 (109)	496 (225)
	1 x 4 (0.75 x 4)	EHYM1-D616DAY-EP	27.38 (696)	5.98 (152)	3.82 (97)	ø6.57 (ø167)	490 (223)	29.88 (759)	5.98 (152)	6.32 (161)	ø6.22 (ø158)	4.80 (122)	4.25 (108)	500 (227)
	1.5 x 4 (1.1 x 4)	EHYM1H-D616DAY-EP	28.44 (723)	6.16 (156)			498 (226)	31.18 (792)	6.16 (156)	6.56 (167)	ø6.57 (ø167)	5.04 (128)	4.61 (117)	509 (231)
	2 x 4 (1.5 x 4)	EHYM2-D616DAY-EP					501 (227)						512 (233)	
D616DB	1.5 x 4 (1.1 x 4)	EHYM1H-D616DBY-EP	29.00 (737)	6.16 (156)	4.53 (115)	ø6.57 (ø167)	502 (228)	31.73 (806)	6.16 (156)	6.56 (167)	ø6.57 (ø167)	5.04 (128)	4.61 (117)	514 (233)
	2 x 4 (1.5 x 4)	EHYM2-D616DBY-EP	505 (229)				517 (235)							
	3 x 4 (2.2 x 4)	EHYM3-D616DBY-EP	29.82 (758)				6.71 (170)	4.53 (115)					ø7.24 (ø184)	521 (237)

Frames	HPxP (kW x P)	Model	Without Brake					With Brake						
			C	AB	ML	MP ^[1]	Wt	C	AB	ML	MP ^[1]	MS	MT	Wt. lb (kg)
E617DA	1/2 x 4 (0.4 x 4)	EHYM05-E617DAY	25.41 (646)	4.63 (118)	2.32 (59)	ø4.88 (ø124)	626 (284)	26.67 (678)	4.63 (118)	3.58 (91)	ø4.88 (ø124)	2.40 (61)	-	629 (286)
	3/4 x 4 (0.55 x 4)	EHYM08-E617DAY	27.03 (687)	5.67 (144)	3.82 (97)	ø5.94 (ø151)	631 (286)	28.72 (730)	5.67 (144)	5.51 (140)	ø5.94 (ø151)	3.66 (93)	3.94 (100)	637 (289)
	1/2 x 4 (0.4 x 4)	EHYM05-E617DAY-AV					633 (288)							639 (290)
	3/4 x 4 (0.55 x 4)	EHYM08-E617DAY-AV	28.33 (720)	5.86 (149)	3.94 (100)	ø6.30 (ø160)	642 (291)	30.77 (782)	5.86 (149)	6.38 (162)	ø6.30 (ø160)	4.53 (115)	4.29 (109)	652 (296)
	1 x 4 (0.75 x 4)	EHYM1-E617DAY-EP	28.76 (731)	5.98 (152)	3.82 (97)	ø6.57 (ø167)	647 (294)	31.26 (794)	5.98 (152)	6.32 (161)	ø6.22 (ø158)	4.80 (122)	4.25 (108)	656 (298)
	1.5 x 4 (1.1 x 4)	EHYM1H-E617DAY-EP	29.82 (758)	6.16 (156)			654 (297)	32.56 (827)	6.16 (156)	6.56 (167)	ø6.57 (ø167)	5.04 (128)	4.61 (117)	666 (302)
	2 x 4 (1.5 x 4)	EHYM2-E617DAY-EP					657 (298)							668 (303)
E617DB	1.5 x 4 (1.1 x 4)	EHYM1H-E617DBY-EP	30.37 (772)	6.16 (156)	4.53 (115)	ø6.57 (ø167)	659 (299)	33.11 (841)	6.16 (156)	6.56 (167)	ø6.57 (ø167)	5.04 (128)	4.61 (117)	670 (304)
	2 x 4 (1.5 x 4)	EHYM2-E617DBY-EP					662 (300)							673 (306)
	3 x 4 (2.2 x 4)	EHYM3-E617DBY-EP	31.20 (793)				6.71 (170)	4.53 (115)						ø7.24 (ø184)
E617DC	3 x 4 (2.2 x 4)	EHYM3-E617DCY-EP	29.92 (760)	7.34 (186)	4.65 (118)	ø8.74 (ø222)	684 (311)	32.99 (838)	7.34 (186)	8.21 (209)	ø8.74 (ø222)	6.02 (153)	6.30 (160)	701 (318)
	5 x 4 (3.7 x 4)	EHYM5-E617DCY-EP	31.38 (797)				710 (322)	34.94 (888)						734 (333)

Cyclo® HBB

Dimensions

Notes [1]: DM Dimension Symbol ø = Round Fan Cover
DM Dimension Symbol = Square Fan Cover

This page intentionally left blank.

Cyclo® HBB

Dimensions

4

Options

Options: Shaft Diameters

Table 4.1 Available Keyed Hollow Bores (in.)

Bore Size (mm.)	Frame Size					
	Z	A	B	C	D	E
1 3/16	○					
1 1/4	○	○				
1 5/16	○	○				
1 3/8	○	○	○			
1 7/16	○	○	○			
1 1/2	○	○	○			
1 9/16		○	○			
1 5/8		○	○			
1 11/16		○	○			
1 3/4		○	○			
1 13/16		○	○			
1 7/8		○	○			
1 15/16		○	○			
2		○	○			
2 1/16		○	○			
2 1/8		○	○			
2 3/16		○	○	○		
2 1/4			○	○		
2 5/16			○	○		
2 3/8			○	○	○	
2 7/16			○	○	○	
2 1/2			○	○	○	
2 9/16			○	○	○	
2 5/8			○	○	○	
2 11/16				○	○	
2 3/4				○	○	
2 13/16				○	○	
2 7/8				○	○	
2 15/16				○	○	○
3				○	○	○
3 1/16				○	○	○
3 1/8				○	○	○
3 3/16				○	○	○
3 1/4					○	○
3 5/16					○	○
3 3/8					○	○
3 7/16					○	○
3 1/2					○	○
3 9/16					○	○
3 5/8					○	○
3 11/16					○	○
3 3/4					○	○
3 13/16						○
3 7/8						○
3 15/16						○
4						○

Table 4.2 Available Keyed Hollow Bores (mm)

Bore Size (mm.)	Frame Size					
	Z	A	B	C	D	E
30	○					
35	○					
40	○					
45		○				
50		○				
55		○	○			
60			○	○		
65			○	○		
70				○	○	
75				○	○	
80				○	○	○
85					○	○
90					○	○
95						○
100						○
105						○
110						○

Symbols: ○ Optional
Consult factory for price and delivery.

Keyed Hollow Bore

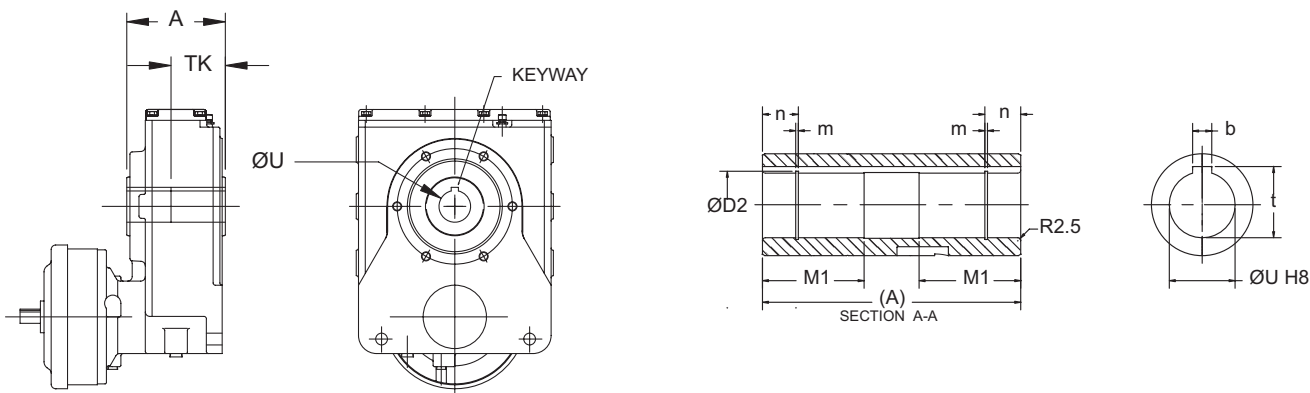

All dimensions are in millimeters.

Model	A	b	t	M1	Ø D2	n	m	TK*
Z	120	12	43.3	57	42.5	24	1.95	76
A	134	16	59.3	63	58	30	2.20	84
B	160	18	69.4	75	68	30	2.70	98
C	192	20	79.9	90	78	37	2.70	140
D	218	22	90.4	100	88.5	37	3.20	194
E	238	28	106.4	110	103.5	37	3.20	195

*Recommended minimum shaft engagement for shaft material 1045 steel with hardness Hb 225 - 265
 ØU shaft diameters are listed in tables 4.1 and 4.2.

Output Flange

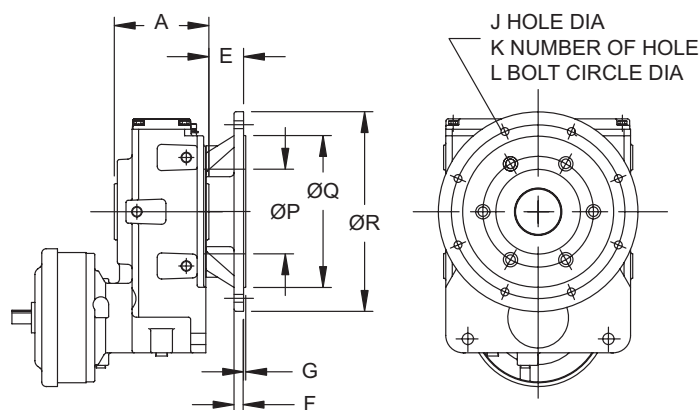

All dimensions are in inches (mm).

Model	A	E	F	G	J	K	L	P	Q	R
Z	4.72 (120)	1.24 (31.5)	0.47 (12)	0.14 (3.5)	0.43 (11)	4	6.50 (165)	3.54 (90)	5.12 (130)	7.87 (200)
A	5.28 (134)	1.30 (33)	0.59 (15)	0.16 (4)	0.55 (14)		8.46 (215)	4.72 (120)	7.09 (180)	10.00 (255)
B	6.30 (160)	1.61 (41)					5.51 (140)			10.00 (254)
C	7.56 (192)	2.28 (58)	0.79 (20)				11.81 (300)	6.50 (165)	9.84 (250)	13.98 (355)
D	8.58 (218)	3.15 (80)	0.87 (22)	0.20 (5)	0.71 (18)	8		7.68 (195)		18.11 (460)
E	9.37 (238)	3.15 (81)							15.75 (400)	12.60 (220)

Options

"T" Type Torque Arm

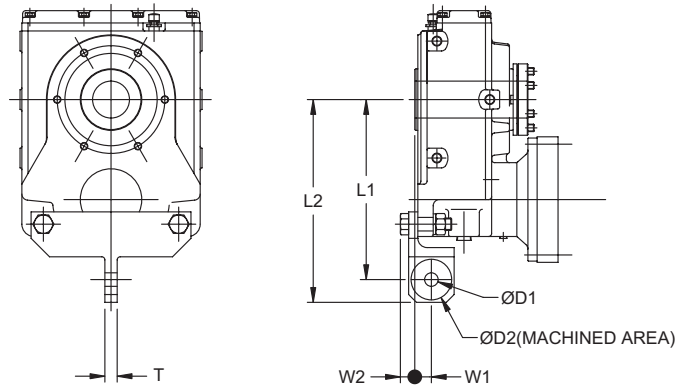

All dimensions are in inches (mm).

Model	L1	L2	W1	W2	T	D1	D2	Bolt Size
Z	8.94 (219)	9.92 (243)	0.71 (17)	0.59 (14)	0.47 (12)	0.55 (14)	1.70 (43)	M12
A	9.39 (230)	10.57 (259)	0.91 (22)	0.67 (16)	0.63 (15)	0.71 (18)	2.09 (53)	M16
B	11.52 (282)	12.97 (318)	1.06 (26)	0.75 (18)	0.79 (19)	0.87 (22)	2.60 (66)	M20
C	14.06 (344)	15.83 (388)	1.26 (31)	1.02 (25)	1.02 (25)	1.02 (26)	3.27 (83)	M24
D	17.05 (418)	18.82 (461)	1.57 (38)	1.18 (29)	1.18 (29)			
E	18.98 (465)	21.14 (518)	2.20 (54)	1.50 (37)	1.42 (35)	1.30 (33)	4.06 (33)	M30

Clevis Type Torque Arm^[1]

Cyclo® HBB

Options

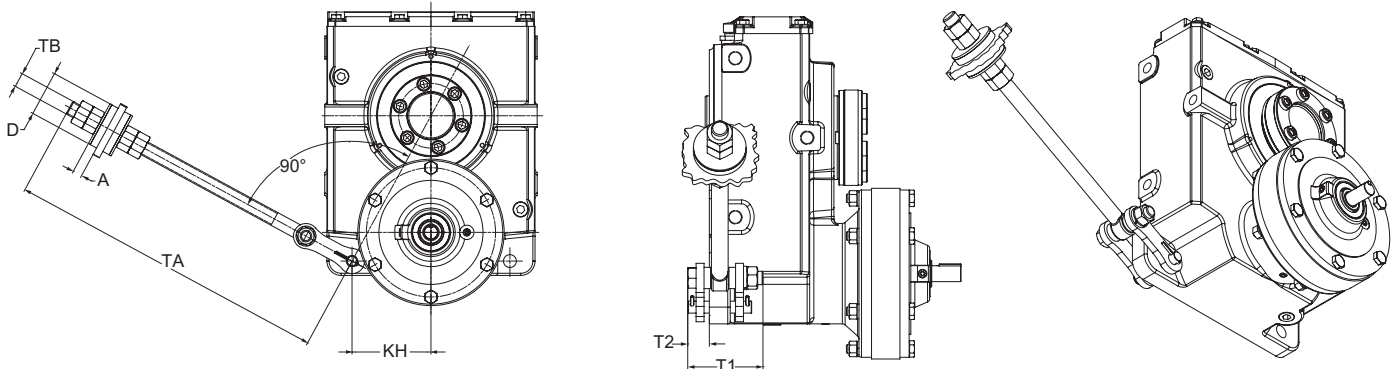

All dimensions are in inches (mm).

Model	A	D	KH	T1	T2	TA	TB
Z	0.63 (16)	2.36 (60)	3.54 (90)	2.40 (61)	0.67 (17)	17.50 (445)	M20
A			3.74 (95)				
B			4.33 (110)				
C	0.75 (19)	3.54 (90)	5.31 (135)	3.90 (99)	1.69 (43)	18.37 (467)	M24
D			6.38 (162)				
E			7.09 (180)				

Note: [1] These clevis type torque arm dimensions also appear in all Cyclo HBB reducer and gearmotor dimension drawings in Sections 2 and 3 of this catalog.

Screw Conveyor Drive

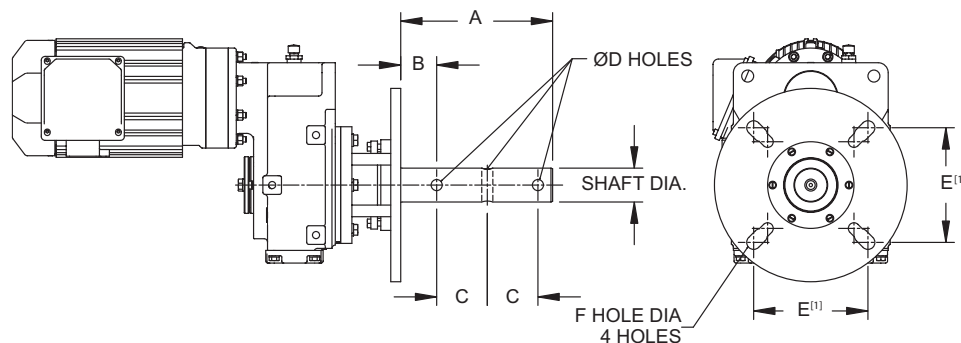

- Complete Cyclo® HBB screw conveyor drive consists of reducer, CEMA drive shaft assembly and mounting adapter kit. The CEMA drive shaft and mounting adapter kit require customer assembly.
- All Cyclo® HBB reducers used as screw conveyor drives require suffix R1, high capacity bearings.
- CEMA drive shafts are three hole style.

All dimensions are in inches.

Model	Shaft Dia.	A	B	C	ØD	E ⁽¹⁾	F
Z, A, B	1-1/2	9	2.13	3	17/32	4	0.531
	2	9	2.13	3	21/32	5.13	0.669
	2-7/16	9.69	2.75	3	21/32	5.63	0.669
	3	9.88	2.88	3	25/32	6	0.827
C, D, E	2	9	2.13	3	21/32	5.13	0.669
	2-7/16	9.69	2.75	3	21/32	5.63	0.669
	3	9.88	2.88	3	25/32	6	0.827
	3-7/16	13.13	3.88	4	29/32	6.75	0.827

Note: [1] The dimension shown is E maximum.

HBB Reducer Model	Drive Shaft Diameter (in.)	To Fit Screw Diameter (in.)	CEMA Steel Drive Shaft Assembly P/N	CEMA Stainless Drive Shaft Assembly P/N	Mounting Adapter Kit P/N
Z	1-1/2	6, 9	117Z4108-C3	117Z4108-S3	117Z4050
	2	9, 12	117Z4200-C3	117Z4200-S3	
	2-7/16	12, 14	117Z4207-C3	117Z4207-S3	
	3	12-20	117Z4300-C3	117Z4300-S3	
A	1-1/2	6, 9	116E4108-C3	116E4108-S3	117A40451
	2	9, 12	116E4200-C3	116E4200-S3	117A40450
	2-7/16	12, 14	116E4207-C3	116E4207-S3	
	3	12-20	116E4300-C3	116E4300-S3	
B	1-1/2	6, 9	116F4108-C3	116F4108-S3	117B4051
	2	9, 12	116F4200-C3	116F4200-S3	117B4050
	2-7/16	12, 14	116F4207-C3	116F4207-S3	
	3	12-20	116F4300-C3	116F4300-S3	
C	2	9, 12	116G4200-C3	116G4200-S3	117C4050
	2-7/16	12, 14	116G4207-C3	116G4207-S3	
	3	12-20	116G4300-C3	116G4300-S3	
	3-7/16	18-24	116G4307-C3	116G4307-S3	
D	2	9, 12	116H4200-C3	116H4200-S3	117D4050
	2-7/16	12, 14	116H4207-C3	116H4207-S3	
	3	12-20	116H4300-C3	116H4300-S3	
	3-7/16	18-24	116H4307-C3	116H4307-S3	
E	2-7/16	12, 14	116J4207-C3	116J4207-S3	117E4050
	3	12-20	116J4300-C3	116J4300-S3	
	3-7/16	18-24	116J4307-C3	116J4307-S3	

Industry Packages

Two food-grade packages are available for use in machinery where there is incidental food contact. (SHIELD360 and Food-Grade)

	Chemical Duty	SHIELD 360*	Food Grade	Low Temp	High Temp	Weather Proof IP54	Wash-down IP55
Motor Portion							
Gasketed Conduit Box	X	X	X			X	X
V Ring Seal- Fan End	X	X	X			X	X
Special Oil Seal				X	X		
Special Windings				X	X		
Sealer @ Joints	X	X	X			X	X
Special Fan				X	X		
Epoxy Paint	X						X
FDA Epoxy Paint			X				
FDA White Top Coat		X					
FDA Stainless Steel Top Coat							
Brake Cover and Seal	X	X				X	X
Reducer Portion							
Severe Duty Breather	X	X				X	X
Epoxy Paint	X						X
FDA Epoxy Paint			X				
FDA White Top Coat		X					
FDA Stainless Steel Top Coat							
FDA Grease Oil/Grease		X	X				
Low Temp Grease / Oil				X			
High Temp Grease / Oil					X		
Double Output Seals	X	X	X	X	X	X	X
High Temperature Seals					X		
Low Temperature Seals				X			
FKM AM & Chemical	X						
Stainless or Tesa Nameplate	X						

Standard unit temperature range is -10 degrees C to 40 degrees C.

Low Temp Package = -30 degrees C Maximum. For lower temperature requirements consult factory.

High Temp Package = 50 degrees C Maximum. For higher temperature requirements consult factory.

5

Technical Information

Cyclo® HBB

Technical
Information

Exact Ratios

Exact Ratios for the Helical Buddybox can be calculated as follows:

For Nominal Ratios 11 and 18:1 - the first reduction gear stage is a true planetary configuration. The overall unit reduction ratio is the product of the planetary ratio with the helical stage reduction ratio. Reduction stage ratios can be determined through the gearing tooth count as follows:

$$\text{Calculated Ratio} = (\text{first stage ratio}) \times (\text{second stage ratio}) = \left(\frac{Z_{SUN} + Z_{RING}}{Z_{SUN}} \right) \left(\frac{Z_{GEAR}}{Z_{PINION}} \right)$$

where: $Z_{SUN} \cdot Z_{RING}$ = Number of teeth in the sun gear and ring gear respectively

For Nominal Ratios greater than 18:1 - the primary reduction stage is the Cyclo. Cyclo ratios are exact thus tooth count information is not required for ratio calculation purposes. The overall reduction ratio is the product of the Cyclo ratio with the helical stage reduction ratio.

Table 5.1 Helical Buddybox Tooth Counts and Ratios

Nominal Ratio	Frame Size	Gearing Tooth Count				Calculated Ratio $i_{OVERALL}$
		Planetary		Helical		
		Z_{SUN}	Z_{RING}	Z_{PINION}	Z_{GEAR}	
11	Z6090/5					
	A6100/5	46	92	14	49	10.5000
	B6120/5	60	120	14	49	10.5000
	C6140/5	60	120	14	49	10.5000
	D6160/5	60	126	15	52	10.7467
	E6170/5	58	122	15	52	10.7586
18	Z6090/5					
	A6100/5	30	114	14	49	16.8000
	B6120/5	38	148	14	49	17.1316
	C6140/5	38	148	14	49	17.1316
	D6160/5	39	159	15	52	17.6000
	E6170/5	38	154	15	52	17.5158

Cyclo® HBB

Technical Information

Nominal Ratio	Frame Size	Gearing Tooth Count			Calculated Ratio $i_{OVERALL}$
		Cyclo	Helical		
		i_{CYCLO}	Z_{PINION}	Z_{GEAR}	
21	Z6090/5	6	15	52	20.8000
	A6100/5	6	14	49	21.0000
	B6120/5	6	14	49	21.0000
	C6140/5	6	14	49	21.0000
	D6160/5	6	15	52	20.8000
	E6170/5	6	15	52	20.8000
28	Z6090/5	8	15	52	27.7333
	A6100/5	8	14	49	28.0000
	B6120/5	8	14	49	28.0000
	C6140/5	8	14	49	28.0000
	D6160/5	8	15	52	27.7333
	E6170/5	8	15	52	27.7333

Exact Ratios

Table 5.1 Helical Buddybox Tooth Counts and Ratios (continued)

Nominal Ratio	Frame Size	Gearing Tooth Count			Calculated Ratio $i_{OVERALL}$
		Cyclo	Helical		
		i_{CYCLO}	Z_{PINION}	Z_{GEAR}	
39	Z6090/5	11	15	52	38.1333
	A6100/5	11	14	49	38.5000
	B6120/5	11	14	49	38.5000
	C6140/5	11	14	49	38.5000
	D6160/5	11	15	52	38.1333
	E6170/5	11	15	52	38.1333
46	Z6090/5	13	15	52	45.0667
	A6100/5	13	14	49	45.5000
	B6120/5	13	14	49	45.5000
	C6140/5	13	14	49	45.5000
	D6160/5	13	15	52	45.0667
	E6170/5	13	15	52	45.0667
53	Z6090/5	15	15	52	52.0000
	A6100/5	15	14	49	52.5000
	B6120/5	15	14	49	52.5000
	C6140/5	15	14	49	52.5000
	D6160/5	15	15	52	52.0000
	E6170/5	15	15	52	52.0000
60	Z6090/5	17	15	52	58.9333
	A6100/5	17	14	49	59.5000
	B6120/5	17	14	49	59.5000
	C6140/5	17	14	49	59.5000
	D6160/5	17	15	52	58.9333
	E6170/5	17	15	52	58.9333
74	Z6090/5	21	15	52	72.8000
	A6100/5	21	14	49	73.5000
	B6120/5	21	14	49	73.5000
	C6140/5	21	14	49	73.5000
	D6160/5	21	15	52	72.8000
	E6170/5	21	15	52	72.8000
88	Z6090/5	25	15	52	86.6667
	A6100/5	25	14	49	87.5000
	B6120/5	25	14	49	87.5000
	C6140/5	25	14	49	87.5000
	D6160/5	25	15	52	86.6667
	E6170/5	25	15	52	86.6667
102	Z6090/5	29	15	52	100.5333
	A6100/5	29	14	49	101.5000
	B6120/5	29	14	49	101.5000
	C6140/5	29	14	49	101.5000
	D6160/5	29	15	52	100.5333
	E6170/5	29	15	52	100.5333
123	Z6090/5	35	15	52	121.3333
	A6100/5	35	14	49	122.5000
	B6120/5	35	14	49	122.5000
	C6140/5	35	14	49	122.5000
	D6160/5	35	15	52	121.3333
	E6170/5	35	15	52	121.3333

Cyclo® HBB

Technical Information

Exact Ratios

Table 5.1 Helical Buddybox Tooth Counts and Ratios (continued)

Nominal Ratio	Frame Size	Gearing Tooth Count			Calculated Ratio $i_{OVERALL}$
		Cyclo	Helical		
		i_{CYCLO}	Z_{PINION}	Z_{GEAR}	
151	Z6090/5	43	15	52	149.0667
	A6100/5	43	14	49	150.5000
	B6120/5	43	14	49	150.5000
	C6140/5	43	14	49	150.5000
	D6160/5	43	15	52	149.0667
	E6170/5	43	15	52	149.0667
179	Z6090/5	51	15	52	176.8000
	A6100/5	51	14	49	178.5000
	B6120/5	51	14	49	178.5000
	C6140/5	51	14	49	178.5000
	D6160/5	51	15	52	176.8000
	E6170/5	51	15	52	176.8000
207	Z6090/5	59	15	52	204.5333
	A6100/5	59	14	49	206.5000
	B6120/5	59	14	49	206.5000
	C6140/5	59	14	49	206.5000
	D6160/5	59	15	52	204.5333
	E6170/5	59	15	52	204.5333
249	Z6090/5	71	15	52	246.1333
	A6100/5	71	14	49	248.5000
	B6120/5	71	14	49	248.5000
	C6140/5	71	14	49	248.5000
	D6160/5	71	15	52	246.1333
	E6170/5	71	15	52	246.1333
305	Z6090/5	87	15	52	301.6000
	A6100/5	87	14	49	304.5000
	B6120/5	87	14	49	304.5000
	C6140/5	87	14	49	304.5000
	D6160/5	87	15	52	301.6000
	E6170/5	87	15	52	301.6000
417	Z6090/5	119	15	52	412.5333
	A6100/5	119	14	49	416.5000
	B6120/5				
	C6140/5				
	D6160/5				
	E6170/5				

Cyclo® HBB

Technical Information

Exact Ratios

Table 5.2 Gearing Tooth Count

Nominal Ratio	FrameSize	Gearing Tooth Count				Exact Ratio
		Helical		Planetary		
		Z _{GEAR}	Z _{PINION}	Z _{SUN}	Z _{RING}	
11	Z6090/5					
	A6100/5	14	49	46	92	10.5000
	B6120/5	14	49	60	120	10.5000
	C6140/5	14	49	60	120	10.5000
	D6160/5	15	52	60	126	10.7467
	E6170/5	15	52	58	122	10.7586
18	Z6090/5					
	A6100/5	14	49	30	114	16.8000
	B6120/5	14	49	38	148	17.1316
	C6140/5	14	49	38	148	17.1316
	D6160/5	15	52	39	159	17.6000
	E6170/5	15	52	38	154	17.5158

Single Reduction

Table 5.3 Single Reduction Exact Ratios

	21	28	39	46	53	60	74	88	102	123	151	179	207	249	305	417
Z	20.80	27.73	38.13	45.07	52.00	58.93	72.80	86.67	100.53	121.33	149.07	176.80	204.53	246.13	301.60	412.53
A	21.00	28.00	38.50	45.50	52.50	59.50	73.50	87.50	101.50	122.50	150.50	178.50	206.50	248.50	304.50	416.50
B	21.00	28.00	38.50	45.50	52.50	59.50	73.50	87.50	101.50	122.50	150.50	178.50	206.50	248.50	304.50	-
C	21.00	28.00	38.50	45.50	52.50	59.50	73.50	87.50	101.50	122.50	150.50	178.50	206.50	248.50	304.50	-
D	20.80	27.73	38.13	45.07	52.00	58.93	72.80	86.67	100.53	121.33	149.07	176.80	204.53	246.13	301.60	-
E	20.80	27.73	38.13	45.07	52.00	58.93	72.80	86.67	100.53	121.33	149.07	176.80	204.53	246.13	301.60	-

Cyclo® HBB

Technical Information

Exact Ratios continued

Double Reduction

Table 5.4 Double Reduction Exact Ratios

	364	424	501	578	683	809	956	1117	1320	1656	1957	2272	2559
Z	360.53	419.47	495.73	572.00	676.00	800.80	946.40	1105.87	1306.93	1639.73	1937.87	2249.87	2534.13
A	364.00	423.50	500.50	577.50	682.50	808.50	955.50	1116.50	1319.50	1655.50	1956.50	2271.50	2558.50
B	364.00	423.50	500.50	577.50	682.50	808.50	955.50	1116.50	1319.50	1655.50	1956.50	2271.50	2558.50
C	364.00	423.50	500.50	577.50	682.50	808.50	955.50	1116.50	1319.50	1655.50	1956.50	2271.50	2558.50
D	360.53	419.47	495.73	572.00	676.00	800.80	946.40	1105.87	1306.93	1639.73	1937.87	2249.87	2534.13
E	360.53	419.47	495.73	572.00	676.00	800.80	946.40	1105.87	1306.93	1639.73	1937.87	2249.87	2534.13

	2944	3511	4365	5177	6472	7228	8880	10658	12184	15530	17966	21620	26492
Z	2915.47	3477.07	4322.93	5127.20	6409.87	7158.67	8794.93	10556.00	12067.47	15381.60	17794.40	-	-
A	2943.50	3510.50	4364.50	5176.50	6471.50	7227.50	8879.50	10657.50	12183.50	15529.50	17965.50	-	-
B	2943.50	3510.50	4364.50	5176.50	6471.50	7227.50	8879.50	10657.50	12183.50	15529.50	17965.50	21619.50	26491.50
C	2943.50	3510.50	4364.50	5176.50	6471.50	7227.50	8879.50	10657.50	12183.50	15529.50	17965.50	21619.50	26491.50
D	2915.47	3477.07	4322.93	5127.20	6409.87	7158.67	8794.93	10556.00	12067.47	15381.60	17794.40	21413.60	26239.20
E	2915.47	3477.07	4322.93	5127.20	6409.87	7158.67	8794.93	10556.00	12067.47	15381.60	17794.40	21413.60	26239.20

Special Load Guidelines Overhung Load

Reducer/Gearmotor Output Shaft Allowable Overhung Load

When a sprocket, sheave, or gear is mounted on the slowspeed of a reducer, an overhung load is applied on that shaft. It is necessary to check if the shaft of the Cyclo® HBB Speed Reducer will allow the overhung load. Calculate the overhung load using the following formulas:

1) Radial load, P_r

$$P_r = \frac{TI}{R} \leq \frac{Pro}{Lf \cdot Cf \cdot Sf} \quad (\text{lbs, } N)$$

2) Axial Load, P_a

$$P_a \leq \frac{Pao}{Cf \cdot Sf} \quad (\text{lbs, } N)$$

3) When there is combined radial and axial loading on the output shaft

$$\left(\frac{P_r}{Pro} + \frac{P_a}{Pao} \right) \cdot Cf \cdot Sf \leq 1 \quad (\text{lbs, } N)$$

LEGEND

- Pr** = Actual radial load (lbs, N)
- TI** = Actual transmitted torque on slow speed shaft of reducer (lb-in, N·m)
- R** = Pitch circle radius of sprocket, gear, pulley, etc. (inch, meter)
- Pro** = Allowable radial load (lbs, N)
- Pa** = Actual axial load (lbs, N)
- Pao** = Allowable axial load (lbs, N)
- Cf** = Coupling factor
- Sf** = Service factor
- Lf** = Load Location factor = 1.0

The values shown in the tables within are the allowable OHL when it is applied to the center of the solid shaft extension or at the load-side edge of the hollow bore. Please consult the factory when the center point of the load is located elsewhere.

Table 5.5 Load Connection Factor (Cf)

Type of Connection		Cf
General Purpose Chain	Single Row	1.00
	Double Row	1.25
Machined Gear or Pinion		1.25
Synchronous Belt		1.50
V-Belt		1.50
Flat Belt		2.50

Table 5.6 Shock Factor (Fs)

Force Units: lbs, (N)

Shock Factor	Fs
No Shock	1.0
Moderate Shock	1.3
Heavy Shock	1.6

Table 5.7 Input Shaft Overhung Load Location Factor, Lf

Model	L (inches)									
	0.25 (6.35)	0.50 (12.7)	0.75 (19.05)	1.00 (25.4)	1.25 (31.75)	1.50 (38.1)	1.75 (44.45)	2.00 (50.8)	2.50 (63.5)	3.00 (76.2)
Z6090, Z6095	0.90	1.09	1.52	2.03						
A6100, A6105	0.93	1.09	1.52	2.03						
B6120, B6125		0.87	1.10	1.43	1.77	2.12				
C6140, C6145		0.84	0.98	1.25	1.53	1.83	2.11			
D6160, D6165		0.94	0.97	1.06	1.22	1.36	1.51	1.66		

Figure 5.1

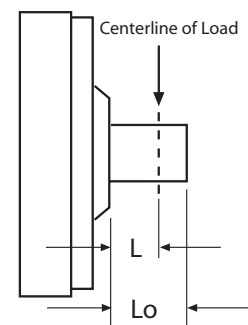

Cyclo® HBB

Technical Information

Special Load Guidelines Output Shaft Overhung Load continued

Table 5.8 Input Shaft Allowable Overhung Load (Lf, Cf, Fs =1)

Unit: lbs.

Model	Ratio	Shaft Speed (RPM)						
		1750	1450	1165	980	870	720	580
Z6090, Z6095	25~71, 119	66	66	66	66	66	66	66
	21, 87	44	44	44	44	55	55	66
A6100, A6105	6~11, 17~119	99	99	110	121	132	132	132
	13, 15	99	77	99	110	110	121	132
B6120, B6125	6~17	133	155	166	175	198	198	198
	21~87	121	99	110	121	133	198	198
C6140, C6145	6, 8	308	308	308	342	364	387	418
	11~21	277	220	243	265	277	297	330
	25	243	254	265	288	297	308	330
	29~87	121	133	133	155	155	155	243
D6160, D6165	8~25, 51, 59	398	398	441	463	486	486	486
	29~43, 71, 87	243	265	288	308	308	353	398
E6170, E6175	11~87	463	463	508	508	528	551	596

Special Load Guidelines **Inertia** continued

Table 5.9 Moment of Inertia on Motor Shaft of N-Frame Integral Motor

Units: lb-inch² ($\times 10^{-4}$ kg-m²)

Model	Reduction Ratio								
	11	18	21	28	39	46	53	60	74
Z6090, Z6095	–	–	0.475	0.337	0.247	0.245	0.231	0.200	0.150
A6100, A6105	1.737	0.711	0.513	0.331	0.191	0.173	0.149	0.108	0.108
B6120, B6125	5.609	2.213	17.408	1.245	0.735	0.728	0.660	0.496	0.530
C6140, C6145	14.638	5.711	5.130	3.263	2.124	1.662	1.443	1.245	1.019
D6160, D6165	41.724	16.382	13.441	8.721	5.369	4.617	4.036	3.379	2.965
E6170, E6175	87.210	35.226	32.866	22.640	16.142	14.159	12.244	11.457	10.328

Model	Reduction Ratio							
	88	102	123	151	179	207	249	305
Z6090, Z6095	0.142	0.118	0.091	0.088	0.085	0.063	0.083	0.062
A6100, A6105	0.095	0.066	0.059	0.054	0.071	0.048	0.067	0.045
B6120, B6125	0.482	0.340	0.316	0.295	0.400	0.276	0.386	0.263
C6140, C6145	0.913	0.821	0.770	0.708	0.681	0.674	0.650	0.643
D6160, D6165	2.698	2.370	2.226	2.090	2.035	2.028	1.925	1.888
E6170, E6175	9.747	9.166	8.858	8.550	8.413	8.276	8.208	8.140

Cyclo® HBB



Special Load Guidelines Inertia continued

Table 5.10 Moment of Inertia on Motor Shaft of N-Frame Integral Motor

Units: lb-inch² (x 10⁻⁴ kg-m²)

1 HP (0.75 kW) x 4 Pole		1.5 HP (1.1 kW) x 4 Pole		2 HP (1.5 kW) x 4 Pole		3 HP (2.2 kW) x 4 Pole		5 HP (3.7 kW) x 4 Pole	
Standard	w/ Brake	Standard	w/ Brake	Standard	w/ Brake	Standard	w/ Brake	Standard	w/ Brake
8.03 (23.5)	8.82 (25.8)	11.5 (33.7)	13.5 (39.6)	13.4 (39.1)	15.4 (45)	30.1 (88)	33.4 (97.8)	66.3 (194)	71.4 (209)
7.5 HP (5.5 kW) x 4 Pole		10 HP (7.5 kW) x 4 Pole		15 HP (11 kW) x 4 Pole		20 HP (15 kW) x 4 Pole		25 HP (18.5 kW) x 4 Pole	
Standard	w/ Brake	Standard	w/ Brake	Standard	w/ Brake	Standard	w/ Brake	Standard	w/ Brake
99.4 (291)	105 (306)	140 (409)	154 (450)	192 (561)	206 (602)	340 (995)	393 (1150)	875 (2560)	926 (2710)
30 HP (22 kW) x 4 Pole		40 HP (30 kW) x 4 Pole							
Standard	w/ Brake	Standard	w/ Brake						
875 (2560)	926 (2710)	1110 (3260)	1170 (3420)						

Table 5.11 Moment of Inertia on Motor Shaft of V-Frame Standard Integral Motor

Units: lb-inch² (x 10⁻⁴ kg-m²)

1/8 HP (0.1 kW) x 4 Pole		1/4 HP (0.2 kW) x 4 Pole		1/3 HP (0.25 kW) x 4 Pole		1/2 HP (0.4 kW) x 4 Pole		3/4 HP (0.55 kW) x 4 Pole	
Standard	w/ Brake	Standard	w/ Brake	Standard	w/ Brake	Standard	w/ Brake	Standard	w/ Brake
1.11 (3.25)	1.2 (3.5)	1.71 (5)	1.88 (5.5)	1.71 (5)	1.88 (5.5)	2.22 (6.5)	2.31 (6.75)	3.45 (10.1)	3.79 (11.1)

Table 5.12 Moment of Inertia on Motor Shaft of V-Frame AF Integral Motor

Units: lb-inch² (x 10⁻⁴ kg-m²)

1/8 HP (0.1 kW) x 4 Pole		1/4 HP (0.2 kW) x 4 Pole		1/3 HP (0.25 kW) x 4 Pole		1/2 HP (0.4 kW) x 4 Pole		3/4 HP (0.55 kW) x 4 Pole	
Standard	w/ Brake	Standard	w/ Brake	Standard	w/ Brake	Standard	w/ Brake	Standard	w/ Brake
1.71 (5)	1.88 (5.5)	2.22 (6.5)	2.31 (6.75)	2.22 (6.5)	2.31 (6.75)	4.1 (12)	4.44 (13)	6.32 (18.5)	7.11 (20.8)

Special Load Guidelines Misc.

Cyclo® HBB

Technical Information

Excessive Overloads

Cyclo® HBB Speed Reducers provide 300% momentary intermittent shock load capacity and are warranted for two years from date of shipment. Refer to our standard terms and conditions for our complete warranty.

Selection for Applications Involving Shock Loading

For applications involving frequent start-stop, review the recommendations in the selection procedure. For braking or reversing, or quick starting of loads having large inertia, consult factory for model selection or recommended modifications.

Allowable Radial and Thrust Loads

The loads imposed on the reducer shafts vary with the method of connecting the shaft to the driven machine. Frequently, in addition to torsional forces, radial and thrust loads are applied to the slow speed shaft at the same time. For example,

coupling connections normally involve torsional forces only. However, when power is transmitted through spur gears, belts, pulleys or chains, both torsional and radial forces may be applied to the reducer shafts. When driving through helical gears, all three conditions (torsional, radial and thrust load) may be referred to the reducer shaft.

The reducer shafts and bearings must have sufficient strength to withstand these loads, and it is, therefore, necessary to determine the allowable limits for each condition. Please consult factory for further information.

Load Centering

The radial load capacities are calculated with the load concentrated at the midpoint of the slow speed shaft extension. Radial load capacities decrease if the center of the load is moved farther from the reducer and the values obtained from the charts must be adjusted accordingly..

Lubrication

Oil lubricated models are not filled with oil prior to shipping.

Before operating, fill the unit with the appropriate amount of the correct lubricant for the mounting position (see Table 5.13). When operating in winter or other relatively low ambient temperatures, use the lower viscosity oil specified for each ambient temperature range. Please consult the factory if the unit will be operated consistently in ambient temperatures other than 32°F–104°F.

Grease lubricated models are lubricated with grease prior to shipment from the factory.

Adding grease prior to initial start-up is not required. If grease must be replenished or changed (see Grease Lubrication section), avoid using greases other than those shown in Table 5.14. Please consult the factory when the units will be used in widely fluctuating temperatures, ambient temperatures other than those specified in Table 5.15, or when other special conditions exist for the application. When motors from another manufacturer will be used, please consult and adhere to the associated motor maintenance manual for the appropriate lubrication instructions.

Table 5.13 Lubrication Type

Unit Size	Output (Helical Gear Portion)	Input (Cyclo® Portion)		
		Motor Horizontal	Motor Vertical Up	Motor Vertical Down
All	Oil	Oil	Oil	Grease

Table 5.14 Approved Oils

ExxonMobil	Spartan EP	Idemitsu	Daphne Super Gear Oil	BP	Energol GR-XP
Mobil	Mobilgear 600XP	Kluber	Kluberoll GEM1	Castrol	Alpha SP
Shell	Omala S2 G	Caltex	Meropa	Gulf	EP Lubricant HD

Ambient Temperature							
°F	14	32	50	68	86	104	122
°C	-10	0	10	20	30	40	50
ISO VG	68		100/150			220/320/460	

Table 5.15 Approved Greases

Ambient Temperature		Cyclo (Input) Portion	
°F	°C	Ratios 11, 18:1	Ratios 21:1 and higher
14 to 122	-10 to 50	Shell Gadus S2 V220 0	Exxon Unirex N2

Figure 5.2 Oil Plug Locations

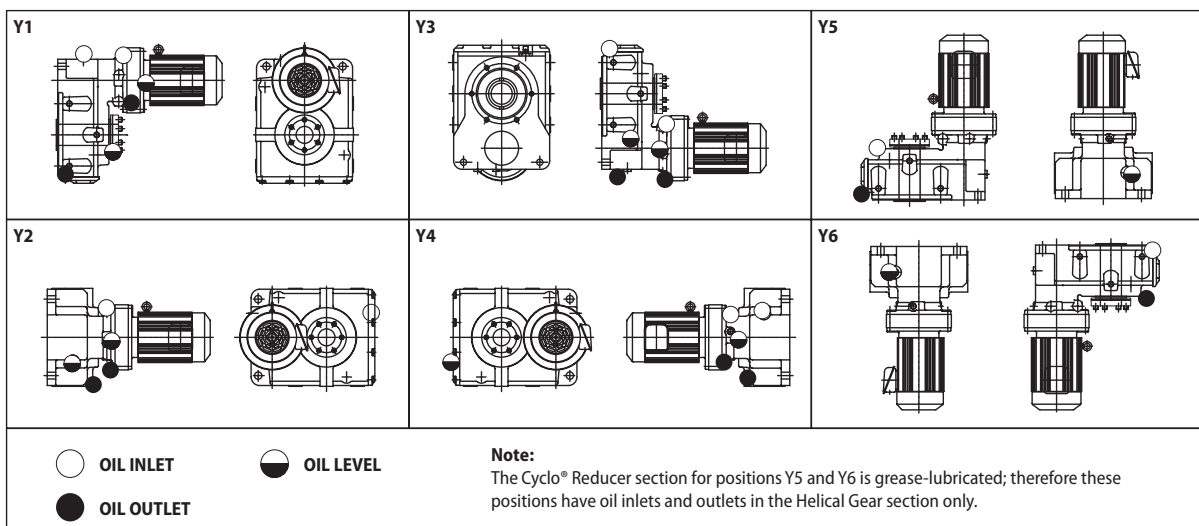

Cyclo® HBB

Technical Information

Lubrication continued

Oil Quantities

Table 5.16 Oil Fill Quantities

*G = Grease

Model		Y1		Y2		Y3		Y4		Y5		Y6	
		Ltr.	Gal.	Ltr.	Gal.	Ltr.	Gal.	Ltr.	Gal.	Ltr.	Gal.	Ltr.	Gal.
Z609	Output	0.5	0.13	0.5	0.13	0.5	0.13	0.5	0.13	1.4	0.37	0.8	0.21
	Input	G	G	G	G	G	G	G	G	G	G	G	G
A610	Output	0.7	0.18	0.8	0.21	0.7	0.18	0.7	0.18	1.6	0.42	1.1	0.29
	Input	G	G	G	G	G	G	G	G	G	G	G	G
B612	Output	1.4	0.37	1.6	0.42	1.2	0.32	1.6	0.42	3.3	0.87	2.2	0.58
	Input	G	G	G	G	G	G	G	G	G	G	G	G
C614	Output	1.8	0.48	2.3	0.61	1.6	0.42	2.3	0.61	5.2	1.37	3.4	0.9
	Input	0.3	0.08	0.3	0.08	0.3	0.08	0.3	0.08	G	G	G	G
D616	Output	4.4	1.16	4.7	1.24	3.4	0.90	4.6	1.22	9.6	2.54	7.4	1.95
	Input	0.6	0.16	0.6	0.16	0.6	0.16	0.6	0.16	G	G	G	G
E617	Output	5.6	1.48	6.8	1.80	4.1	1.08	6.7	1.77	13	3.43	10.1	2.67
	Input	0.9	0.24	0.9	0.24	0.9	0.24	0.9	0.24	G	G	G	G

Oil lubricated units are shipped without oil. Prior to initial start-up, the unit must be filled with the correct amount of oil (see Table 5.16). For those units where both the gear and Cyclo® portions are oil lubricated, the oil must be filled in two separate locations, one on the gear housing and one on the Cyclo® housing.

The helical (output) portion of all **double reduction units** is oil lubricated and must be filled by the customer with the correct amount of oil (see Table 5.16) prior to initial start-up.

Grease lubricated models are lubricated at the factory. Additional grease does not need to be added prior to initial start-up.

The Cyclo® (input) portion of all **double reduction units** are grease lubricated at the factory. Additional grease does not need to be added prior to initial start-up.

Grease Replenishment and Change Interval

- A. On single reduction Cyclo® Helical Buddybox (Cyclo® HBB) sizes Z6090/95, A6100/05 and B6120/25, the Cyclo® portion is grease lubricated as standard and therefore maintenance free. Consult the operations and maintenance manual for the grease change interval.
- B. When mounting Cyclo® HBB sizes C6140/45, D6160/65 and E6170/75 in the Y5 and Y6 positions, please consult the maintenance and operations manual for the proper grease replenishment and change interval for the Cyclo® portion.

Oil Replenishment and Change Interval

- A. Maintain proper oil levels at all times.
- B. An oil change after the first 500 hours of operation is highly recommended.
- C. Sumitomo recommends an oil change every 2500 hours, or six months, whichever comes first. If a proper preventive maintenance program is implemented and maintained, a longer change period may be acceptable.
- D. If the unit is running in a high ambient, high humidity, or corrosive environment, the lubricant will have to be changed more frequently. Consult the factory for recommendations.
- E. Note: The Cyclo® portion and Helical portion, where applicable, must be filled with oil separately. Oil does not flow from one section to the other.

Cyclo® HBB

Technical Information

North American Motor Specifications

Feature	All Motors
Motor Type	3-Phase AC Asynchronous Squirrel Cage Induction Motor
Motor Standard	NEMA
Power Range	1/8 through 40 HP (0.1 through 30 kW)
Number of Poles	4 Poles
Motor Power Supply	230 / 460 Volts, 60 Hz, 3 phase 575 Volts, 60 Hz, 3 phase
Synchronous RPM (Slip)	1800 RPM (20 - 100 RPM - See Motor Nameplate)
NEMA Design	A or B (See Motor Nameplate)
Efficiency	1/8 through 3/4 HP (Standard Efficiency - IE1) 1 through 40 HP (Premium Efficiency - IE3)
Motor Temperature Rise	Class B
Motor Insulation	Class F Tropicalized
Service Factor	Sinusoidal Utility Power: 1.15, Inverter Power: 1.0
Time Rating	Continuous
Frame Material	Diecast Aluminum
Enclosure Type	1/8 HP - TENV, 1/4 HP - 40 HP - TEFC
Enclosure Rating	IP55 Outdoor and Indoor Neoprene v-ring, gaskets and slinger shaft seals
Conduit Box	Outdoor Gasketed Oversized Diecast Aluminum, NPT Conduit Thread (Optional Indoor Steel)
Certification	UL Recognition, CSA Certification, CE Marked
Inverter Compatibility	Motor Insulation MG1 Part 31 Compliant
Constant Torque Speed Range	See Below
Overspeed Operation	Up to 120 Hz Check Reducer and Driven Equipment Overspeed Rating!
Motor Bearings	Double shielded, Deep Groove, Sealed for Life, CM Reduced Clearance Ball Bearings
Fan Guard (TEFC)	Steel
Fan (TEFC)	1/8 - 3/4 HP (PBT) 1 - 40 HP (Nylon Resin - PA66 with 30% Glass Fiber)
Lifting Provisions	(1 - 40 HP) Eyebolt

Cyclo® HBB

Technical Information

Feature	Non-Brake Motor	Brake Motor
Constant Torque Speed Range	See page 3.8 for table.	See page 3.8 for table.
208V Motor Power	Usable on 208V Network	Motor usable on 208V network but supply 230V for brake control
Brake Power Supply	-----	230 / 460 Volts, 60 Hz, 1 phase 575 Volts, 60 Hz, 1 phase
Brake Insulation	-----	Class F
Manual Brake Release Mechanism	-----	1/8 - 1/2 HP - no release mechanism 3/4 - 40 HP - one-touch lever type release

Motor Optional Conduit Box Location

NOTE: Default Terminal Box position for Gearmotors is N33/ N3B for all mounting positions (Y1 thru Y6).
 ← : The arrow indicates direction of lead wire out of conduit box.

Standard Mounting Direction of Terminal Box

The terminal box mounting position can be rotated in increments of 90 degrees (N33, N34, N35, N36).
 The terminal box cable entry port can also be rotated in increments of 90 degrees (N3A, N3B, N3C, N3D).
 Specify the terminal box mounting configuration based on figures shown below.
 The conduit box orientation is shown relative to HBB casing. For orientation of the HBB, please see page 1.7.

Figure 5.3 Terminal Box Mounting Options for Y1 Position

Cable Port Direction	Terminal Box Mounting Position (As viewed from Motor Fan Side)			
	Left Side (N33) (Viewed from Output Shaft Side)	Right Side (N34) (Viewed from Output Shaft Side)	Top Side (N35)	Bottom Side (N36)
Type A (N3A)				
Type B (N3B)				
Type C (N3C)				
Type D (N3D)				

Figure 5.4 Terminal Box Mounting Options for Y2, Y3, Y4, Y5, Y6 Positions

Cable Port Direction	Terminal box mounting position (As viewed from Motor Fan Side)			
	Left Side (N33) (Viewed from Output Shaft Side)	Right Side (N34) (Viewed from Output Shaft Side)	Top Side (N35)	Bottom Side (N36)
Type A (N3A)				
Type B (N3B)				
Type C (N3C)				
Type D (N3D)				

Special consideration must be given to terminal box location N35 in mounting position Y2 if the unit is oil lubricated. The conduit box may interfere with the unit's oil plumbing system. Another conduit box location should be selected if possible. If location N35 must be used, consult the factory.

Motor Installation: Fan/Brake Cover Clearance Requirements

Required gearmotor clearance dimension FA and FB for installation to achieve best performance and proper maintenance.

Dimension FA: Clearance dimension necessary to remove fan cover or brake cover without removing the motor from the equipment.

Dimension FB: Minimum clearance to provide adequate ventilation.

- Notes:**
1. In some cases, it may be necessary to move the gearmotor to remove the fan cover or brake cover.
 2. Dimension FB is the minimum clearance when the fan cover is up against a closed wall.

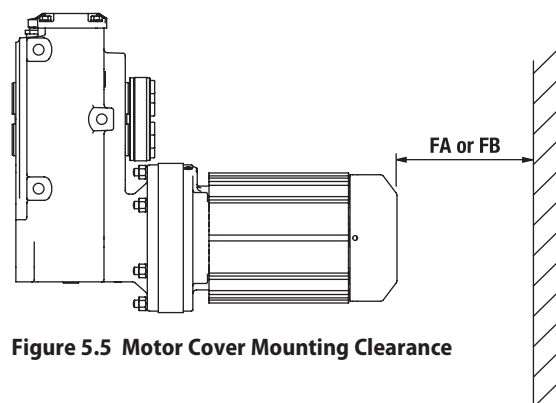

Figure 5.5 Motor Cover Mounting Clearance

Table 5.17a Motor Clearance Requirements for Standard IE1 motors (1/8 to 3/4 hp)

inch (mm)

IE1 Motor			Standard 3-Phase Motor		3-Phase With Brake Motor	
Frame Size	HP x Pole	kW x Pole	FA	FB	FA	FB
V-63S	1/8 x 4	0.1 x 4	-	-	2.0 (49)	-
V-63M	1/4 x 4	0.2 x 4	1.9 (48)	0.8 (20)	2.5 (63)	0.8 (20)
V-63M	1/3 x 4	0.25 x 4				
V-71M	1/2 x 4	0.4 x 4	1.9 (48)	0.8 (20)	2.5 (63)	0.8 (20)
V-80S	3/4 x 4	0.55 x 4	2.0 (49)	0.8 (20)	3.7 (93)	0.8 (20)

Table 5.17b Motor Clearance Requirements for AF - motors (1/8 to 3/4 hp)

inch (mm)

IE1 Motor			Standard 3-Phase Motor		3-Phase With Brake Motor	
Frame Size	HP x Pole	kW x Pole	FA	FB	FA	FB
VA-63S	1/8 x 4	0.1 x 4				
VA-63M	1/4 x 4	0.2 x 4	1.9 (48)	0.8 (20)	2.5 (63)	0.8 (20)
VA-63M	1/3 x 4	0.25 x 4				
VA-71M	1/2 x 4	0.4 x 4	2.0 (49)	0.8 (20)	3.7 (93)	0.8 (20)
VA-80S	3/4 x 4	0.55 x 4	2.1 (52)	0.8 (20)	4.6 (115)	0.8 (20)

Table 5.17c Motor Clearance Requirements for EP motors (1 to 15 hp)

inch (mm)

IE3 Motor			3-Phase Without Brake Motor		3-Phase Brake (B) Motor	
Frame Size	HP x Pole	kW x Pole	FA	FB	FA	FB
N-80M	1 x 4	0.75 x 4	2.3 (59)	0.8 (20)	4.8 (122)	0.8 (20)
N-90S	1.5 x 4	1.1 x 4				
N-90L	2 x 4	1.5 x 4	2.3 (59)	0.8 (20)	5.0 (128)	0.8 (20)
N-100L	3 x 4	2.2 x 4	2.4 (60)	0.8 (20)	5.4 (138)	0.8 (20)
N-112M	5 x 4	3.7 x 4				
N-132S	7.5 x 4	5.5 x 4	2.5 (63)	1.0 (25)	6.0 (153)	0.8 (20)
N-132M	10 x 4	7.5 x 4				
N-160M	15 x 4	11 x 4	3.3 (84)	1.2 (30)	7.4 (189)	1 (25)
N-160L	20 x 4	15 x 4	4.2 (107)	1.2 (30)	9.5 (242)	1.2 (30)
N-180MS	25 x 4	18.5 x 4				
N-180M	30 x 4	22 x 4	5.3 (134)	1.2 (30)	12.1 (308)	1.2 (30)
N-180L	40 x 4	30 x 4				

Cyclo® HBB

Technical
Information

Motor continued

Motor Conduit Box Details

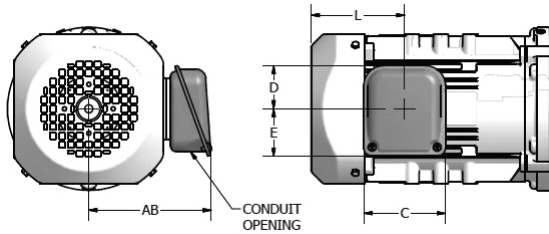

Figure 5.6 Indoor Duty (Optional) Box

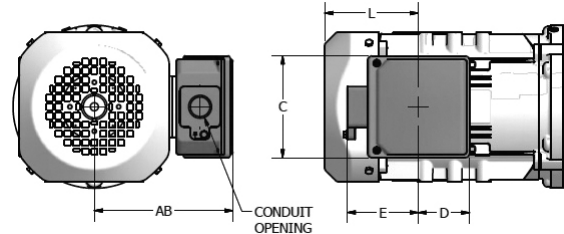

Figure 5.7 Global EP.NA and Outdoor Duty Box

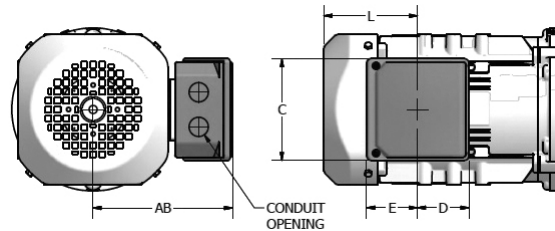

Figure 5.8 Global IE3 CE Box

Table 5.18 Conduit Box Information

inch (mm)

Frame Size	Duty Rating	General Dimensions				Without Brake		With Brake		Conduit Opening	Material
		AB	C	D	E	Availability	L	Availability	L		
V-63S	Indoor Duty (Optional)	4.11 (105)	3.35 (85)	2.09 (53)	1.69 (43)	Yes	1.38 (35)	CF ⁽¹⁾	2.76 (70)	Ø0.90 (Ø23)	Steel
	Indoor Duty Brake (Optional)	4.32 (110)	3.94 (100)	2.29 (58)	2.10 (53)			Yes		Ø0.90 (Ø23)	Steel
	Outdoor Duty (Optional)	4.98 (127)	3.94 (100)	2.42 (62)	2.76 (70)			Yes		NPT1/2 ⁽²⁾	Steel
	Global	4.63 (118)	4.09 (104)	2.24 (57)	2.16 (55)			Yes		NPT1/2	Al Diecast
	Global CE	4.63 (118)	4.09 (104)	2.24 (57)	2.16 (55)			Yes		M16, M25	Al Diecast
VA-63S V-63M VA-63M V-71M	Indoor Duty (Optional)	4.11 (105)	3.35 (85)	2.09 (53)	1.69 (43)	Yes	2.32 (59)	CF ⁽¹⁾	3.58 (91)	Ø0.90 (Ø23)	Steel
	Indoor Duty Brake (Optional)	4.32 (110)	3.94 (100)	2.29 (58)	2.10 (53)			Yes		Ø0.90 (Ø23)	Steel
	Outdoor Duty (Optional)	4.98 (127)	3.94 (100)	2.42 (62)	2.76 (70)			Yes		NPT1/2 ⁽²⁾	Steel
	Global	4.63 (118)	4.09 (104)	2.24 (57)	2.16 (55)			Yes		NPT1/2	Al Diecast
	Global CE	4.63 (118)	4.09 (104)	2.24 (57)	2.16 (55)			Yes		M16, M25	Al Diecast
VA-71M V-80S	Indoor Duty (Optional)	4.69 (119)	3.35 (85)	1.72 (44)	2.04 (52)	Yes	3.82 (97)	CF ⁽¹⁾	5.51 (140)	Ø0.90 (Ø23)	Steel
	Indoor Duty Brake (Optional)	5.68 (144)	4.80 (122)	2.60 (66)	2.84 (72)			Yes		Ø0.90 (Ø23)	Steel
	Outdoor Duty (Optional)	5.55 (141)	3.94 (100)	2.20 (56)	2.95 (75)			Yes		G3/4 ⁽²⁾	Steel
	Global	5.67 (144)	4.92 (125)	2.50 (64)	3.43 (87)			Yes		NPT3/4 ⁽²⁾	Al Diecast
	Global CE	5.71 (145)	4.92 (125)	2.50 (64)	2.47 (63)			Yes		2 - M25	Al Diecast
VA-80S	Indoor Duty (Optional)	4.88 (124)	3.35 (85)	1.72 (44)	2.04 (52)	Yes	3.94 (100)	CF ⁽¹⁾	6.38 (162)	Ø0.90 (Ø23)	Steel
	Indoor Duty Brake (Optional)	5.87 (149)	4.80 (122)	2.60 (66)	2.84 (72)			Yes		Ø0.90 (Ø23)	Steel
	Outdoor Duty (Optional)	5.75 (146)	3.94 (100)	2.20 (56)	2.95 (75)			Yes		G3/4 ⁽²⁾	Steel
	Global	5.86 (149)	4.92 (125)	2.50 (64)	3.43 (87)			Yes		NPT3/4 ⁽²⁾	Al Diecast
	Global CE	5.91 (150)	4.92 (125)	2.50 (64)	2.47 (63)			Yes		2 - M25	Al Diecast

(1) For "Available?" identified with "CF", please consult factory for brake configuration supporting this conduit box.

(2) Default thread option shown. Alternate thread options available. Please consult factory for alternate conduit thread options

Table 5.18 Conduit Box Information (cont.)

Frame Size	Duty Rating	General Dimensions				Without Brake		With Brake		Conduit Opening	Material
		AB	C	D	E	Availability	L	Availability	L		
N-80M	Indoor Duty (Optional)	4.85 (123)	3.35 (85)	1.72 (44)	2.04 (52)	Yes	3.82 (97)	CF ⁽¹⁾	6.32 (161)	Ø0.90 (Ø23)	Steel
	Indoor Duty Brake (Optional)	5.99 (152)	4.80 (122)	2.60 (66)	2.84 (72)			Yes		Ø0.90 (Ø23)	Steel
	Outdoor Duty (Optional)	5.87 (149)	3.94 (100)	2.20 (56)	2.95 (75)			Yes		G3/4 ⁽²⁾	Steel
	Global EP.NA	5.98 (152)	4.92 (125)	2.50 (64)	3.43 (87)			Yes		NPT3/4 ⁽²⁾	Al Diecast
	Global IE3 CE	6.02 (153)	4.92 (125)	2.50 (64)	2.47 (63)			Yes		2 - M25	Al Diecast
N-90S N-90L	Indoor Duty (Optional)	5.03 (128)	3.35 (85)	1.72 (44)	2.04 (52)	Yes	3.82 (97)	CF ⁽¹⁾	6.56 (167)	Ø0.90 (Ø23)	Steel
	Indoor Duty Brake (Optional)	6.17 (157)	4.80 (122)	2.60 (66)	2.84 (72)			Yes		Ø0.90 (Ø23)	Steel
	Outdoor Duty (Optional)	6.04 (154)	3.94 (100)	2.20 (56)	2.95 (75)			Yes		G3/4 ⁽²⁾	Steel
	Global EP.NA	6.16 (156)	4.92 (125)	2.50 (64)	3.43 (87)			Yes		NPT3/4 ⁽²⁾	Al Diecast
	Global IE3 CE	6.20 (158)	4.92 (125)	2.50 (64)	2.47 (63)			Yes		2 - M25	Al Diecast
N-100L N-112S	Indoor Duty (Optional)	5.93 (151)	3.94 (100)	2.09 (53)	2.29 (58)	Yes	4.53 (115)	CF ⁽¹⁾	7.60 (193)	Ø0.90 (Ø23)	Steel
	Indoor Duty Brake (Optional)	6.72 (171)	4.80 (122)	2.60 (66)	2.84 (72)			Yes		Ø0.90 (Ø23)	Steel
	Outdoor Duty (Optional)	7.21 (183)	4.84 (123)	2.52 (64)	3.43 (87)			Yes		G3/4 ⁽²⁾	Steel
	Global EP.NA	6.71 (170)	4.92 (125)	2.50 (64)	3.43 (87)			Yes		NPT3/4 ⁽²⁾	Al Diecast
	Global IE3 CE	6.75 (172)	4.92 (125)	2.50 (64)	2.47 (63)			Yes		2 - M25	Al Diecast
N-112M	Indoor Duty (Optional)	6.56 (167)	3.94 (100)	2.09 (53)	2.29 (58)	Yes	4.65 (118)	CF ⁽¹⁾	8.21 (209)	Ø0.90 (Ø23)	Steel
	Indoor Duty Brake (Optional)	7.35 (187)	4.80 (122)	2.60 (66)	2.84 (72)			Yes		Ø0.90 (Ø23)	Steel
	Outdoor Duty (Optional)	7.84 (199)	4.84 (123)	2.52 (64)	3.43 (87)			Yes		G3/4 ⁽²⁾	Steel
	Global EP.NA	7.34 (186)	4.92 (125)	2.50 (64)	3.43 (87)			Yes		NPT3/4 ⁽²⁾	Al Diecast
	Global IE3 CE	7.38 (188)	4.92 (125)	2.50 (64)	2.47 (63)			Yes		2 - M25	Al Diecast
N-132S	Indoor Duty (Optional)	6.56 (167)	3.94 (100)	2.09 (53)	2.29 (58)	Yes	4.65 (118)	CF ⁽¹⁾	8.21 (209)	Ø0.90 (Ø23)	Steel
	Indoor Duty Brake (Optional)	7.35 (187)	4.80 (122)	2.60 (66)	2.84 (72)			Yes		Ø0.90 (Ø23)	Steel
	Outdoor Duty (Optional)	7.84 (199)	4.84 (123)	2.52 (64)	3.43 (87)			Yes		G1 ⁽²⁾	Steel
	Global EP.NA	7.34 (186)	4.92 (125)	2.50 (64)	3.43 (87)			Yes		NPT1 ⁽²⁾	Al Diecast
	Global IE3 CE	7.38 (188)	4.92 (125)	2.50 (64)	2.47 (63)			Yes		2 - M25	Al Diecast
N-132M	Indoor Duty (Optional)	7.98 (203)	4.80 (122)	2.60 (66)	2.84 (72)	Yes	5.43 (138)	Yes	9.57 (243)	Ø1.69 (Ø43)	Steel
	Outdoor Duty (Optional)	9.26 (235)	6.06 (154)	3.11 (79)	4.13 (105)					G1 ⁽²⁾	Steel
	Global EP.NA	9.04 (230)	6.69 (170)	3.40 (86)	4.43 (113)					NPT1 ⁽²⁾	Al Diecast
	Global IE3 CE	9.04 (230)	6.69 (170)	3.40 (86)	3.51 (89)					2-M32	Al Diecast
N-160M	Indoor Duty (Optional)	7.98 (203)	4.80 (122)	2.60 (66)	2.84 (72)	Yes	5.43 (138)	Yes	9.57 (243)	Ø1.69 (Ø43)	Steel
	Outdoor Duty (Optional)	9.26 (235)	6.06 (154)	3.11 (79)	4.13 (105)					G1-1/4 ⁽²⁾	Steel
	Global EP.NA	9.04 (230)	6.69 (170)	3.40 (86)	4.43 (113)					NPT1-1/4 ⁽²⁾	Al Diecast
	Global IE3 CE	9.04 (230)	6.69 (170)	3.40 (86)	3.51 (89)					2-M32	Al Diecast

Cyclo® HBB

Technical Information

Motor continued

Table 5.18 Conduit Box Information (cont.)

inch (mm)

N-160L	Indoor Duty (Optional)	9.20 (234)	4.80 (122)	2.60 (66)	2.84 (72)	Yes	7.01 (178)	No	12.30 (313)	Ø1.69 (Ø43)	Steel
	Indoor Duty Brake (Optional)	10.16 (258)	6.54 (166)	3.48 (88)	3.89 (99)			Yes		Ø1.69 (Ø43)	Steel
	Outdoor Duty (Optional)	10.48 (266)	6.06 (154)	3.11 (79)	4.13 (105)			Yes		G1-1/4 ⁽²⁾	Steel
	Global EP.NA	10.26 (261)	6.69 (170)	3.40 (86)	4.43 (113)			Yes		NPT1-1/4 ⁽²⁾	Al Diecast
	Global IE3 CE	10.26 (261)	6.69 (170)	3.40 (86)	3.51 (89)			Yes		2-M32	Al Diecast
	Indoor Duty (Optional)	11.69 (297)	6.54 (166)	3.48 (88)	3.89 (99)	Yes	9.06 (230)	Yes	15.91 (404)	Ø1.93 (Ø49)	Steel
	Outdoor Duty (Optional)	14.08 (358)	7.56 (192)	4.53 (115)	6.89 (175)					G1-1/4 ⁽²⁾	Cast Iron
	Global EP.NA	13.39 (340)	9.02 (229)	4.38 (111)	5.47 (139)					NPT1-1/4 ⁽²⁾	Cast Iron
	Global IE3 CE	13.39 (340)	9.02 (229)	4.38 (111)	4.43 (113)					2 - M40	Cast Iron
N-180L N-200L	Indoor Duty (Optional)	11.69 (297)	6.54 (166)	3.48 (88)	3.89 (99)	Yes	9.06 (230)	Yes	15.91 (404)	Ø1.93 (Ø49)	Steel
	Outdoor Duty (Optional)	14.08 (358)	7.56 (192)	4.53 (115)	6.89 (175)					G2 ⁽²⁾	Cast Iron
	Global EP.NA	13.39 (340)	9.02 (229)	4.38 (111)	5.47 (139)					NPT2 ⁽²⁾	Cast Iron
	Global IE3 CE	13.39 (340)	9.02 (229)	4.38 (111)	4.43 (113)					2 - M40	Cast Iron
	Indoor Duty (Optional)	16.24 (413)	9.45 (240)	4.19 (106)	6.30 (160)	Yes	16.81 (427)			Ø3.03 (Ø77)	Steel
	Outdoor Duty (Optional)	19.03 (483)	10.16 (258)	5.28 (134)	11.50 (292)					G2-1/2 ⁽²⁾	Cast Iron
	Global EP.NA	16.54 (420)	10.63 (270)	5.14 (131)	6.22 (158)					NPT3 ⁽²⁾	Cast Iron
	Global IE3 CE	16.54 (420)	10.63 (270)	5.14 (131)	5.13 (130)					2 - M63	Cast Iron

(1) For "Available?" identified with "CF", please consult factory for brake configuration supporting this conduit box.

(2) Default thread option shown. Alternate thread options available. Please consult factory for alternate conduit thread options

Fractional Motor Performance Data - 60Hz Operation

Table 5.19a Three Phase, 230/460V, 60Hz, 1800 RPM Synchronous Speed, TEFC - UL Recognized

Motor Capacity		Frame Size	Full Load (A)			Current				Starting Torque % of FL	Breakdown Torque % of FL	Nominal Efficiency %	Power Factor %	NEMA Code Letter
HP	kW		Rated RPM	Torque		Full Load		No Load % of FL	Starting % of FL					
				in-lbs	N-m	230V	460V							
1/8**	0.1	V-63S	1730	4.55	0.514	0.66	0.33	86.1	424	326	308	63.3	60.0	K
1/4	0.2	V-63M	1730	9.10	1.03	1.12	0.56	79.6	464	300	287	69.2	65.1	K
1/3	0.25	V-63M	1700	12.2	1.38	1.24	0.62	72.0	419	237	226	70.1	72.0	G
1/2	0.4	V-71M	1750	18.0	2.03	2.15	1.08	77.7	456	295	276	71.5	65.4	J
3/4	0.55	V-80S	1720	27.5	3.11	2.47	1.24	68.4	500	266	261	76.5	73.1	H

** 1/8 HP is TENV

Table 5.19b Three Phase, 240/480V, 60Hz, 1800 RPM Synchronous Speed, TEFC - UL Recognized

Motor Capacity		Frame Size	Full Load (A)			Current				Starting Torque % of FL	Breakdown Torque % of FL	Nominal Efficiency %	Power Factor %	NEMA Code Letter
HP	kW		Rated RPM	Torque		Full Load		No Load % of FL	Starting % of FL					
				in-lbs	N-m	240V	480V							
1/8**	0.1	V-63S	1740	4.53	0.512	0.69	0.35	87.4	429	364	341	61.9	56.3	L
1/4	0.2	V-63M	1740	9.05	1.02	1.16	0.58	83.6	466	335	317	68.2	61	K
1/3	0.25	V-63M	1710	12.3	1.39	1.27	0.63	77.0	429	268	238	69.8	68.1	H
1/2	0.4	V-71M	1750	18.0	2.04	2.27	1.13	83.2	460	328	303	70.4	60.4	K
3/4	0.55	V-80S	1730	27.3	3.09	2.52	1.26	73.4	508	294	285	76.0	69.2	H

** 1/8 HP is TENV

Table 5.19c Three Phase, 230/460V, 60Hz, 1800 RPM Synchronous Speed, TEFC - CSA Approved

Motor Capacity		Frame Size	Full Load (A)			Current				Starting Torque % of FL	Breakdown Torque % of FL	Nominal Efficiency %	Power Factor %	NEMA Code Letter
HP	kW		Rated RPM	Torque		Full Load		No Load % of FL	Starting % of FL					
				in-lbs	N-m	230V	460V							
1/8**	0.1	V-63S	1730	4.55	0.514	0.66	0.33	86.1	424	326	308	63.3	60.0	K
1/4	0.2	V-63M	1730	9.10	1.03	1.12	0.56	79.6	464	300	287	69.2	65.1	K
1/3	0.25	V-63M	1700	12.2	1.38	1.24	0.62	72.0	419	237	226	70.1	72.0	G
1/2	0.4	V-71M	1750	18.0	2.03	2.15	1.08	77.7	456	295	276	71.5	65.4	J
3/4	0.55	V-80S	1720	27.5	3.11	2.47	1.24	68.4	500	266	261	76.5	73.1	H

** 1/8 HP is TENV

Table 5.19d Three Phase, 575V, 60Hz, 1800 RPM Synchronous Speed, TEFC - CSA Approved

Motor Capacity		Frame Size	Full Load (A)			Current				Starting Torque % of FL	Breakdown Torque % of FL	Nominal Efficiency %	Power Factor %	NEMA Code Letter
HP	kW		Rated RPM	Torque		Full Load		No Load % of FL	Starting % of FL					
				in-lbs	N-m	575V								
1/8**	0.1	V-63S	1720	4.58	0.518	0.28		91.8	464	376	391	65.5	54.1	M
1/4	0.2	V-63M	1730	9.10	1.03	0.48		85.4	458	316	340	69.4	60.1	K
1/3	0.25	V-63M	1710	12.2	1.38	0.52		78.8	423	250	270	71.3	67.5	H
1/2	0.4	V-71M	1700	18.5	2.09	0.79		75.8	468	309	300	75.2	63.1	J
3/4	0.55	V-80S	1700	27.8	3.14	1.00		74.0	530	260	268	75.4	71.4	H

** 1/8 HP is TENV

Cyclo® HBB

Technical Information

Motor continued

Fractional AF-Motor (AV) Performance Data - 60Hz Operation

Table 5.20a Three Phase, 230/460V, 60Hz, 1800 RPM Synchronous Speed, 10:1 Constant Torque Speed Range TEFC

Motor Capacity		Frame Size	Wiring	Full Load Torque		Voltage V	60 Hz Current Amp	Speed RPM	Voltage V	6 Hz Current Amp	Speed RPM	No Load Current @ 60 Hz
HP	kW			in-lbs	N-m							
1/8	0.1	VA-63S	High Voltage	4.77	0.54	460	0.49	1770	68	0.37	125	0.46
			Low Voltage			230	0.98		34	0.74		0.92
1/4	0.2	VA-63M	High Voltage	9.6	1.08	460	0.91	1765	68	0.79	125	0.87
			Low Voltage			230	1.8		34	1.6		1.74
1/3	0.25	VA-63M	High Voltage	12	1.36	460	0.94	1755	78	0.87	125	0.87
			Low Voltage			230	1.9		34	1.7		1.74
1/2	0.4	VA-71M	High Voltage	19.3	2.18	460	1.3	1750	70	1.1	115	1.21
			Low Voltage			230	2.6		35	2.3		2.42
3/4	0.55	VA-80S	High Voltage	26.4	2.98	460	1.7	1760	62	1.6	125	1.54
			Low Voltage			230	3.3		31	3.1		3.07

Table 5.20b Three Phase, 230/460V, 60Hz, 1800 RPM Synchronous Speed, 10:1 Constant Torque Speed Range TEFC - CSA Approved

Motor Capacity		Frame Size	Wiring	Full Load Torque		Voltage V	60 Hz Current Amp	Speed RPM	Voltage V	6 Hz Current Amp	Speed RPM	No Load Current @ 60 Hz
HP	kW			in-lbs	N-m							
1/8	0.1	VA-63S	High Voltage	4.77	0.54	460	0.49	1770	68	0.37	125	0.46
			Low Voltage			230	0.98		34	0.74		0.92
1/4	0.2	VA-63M	High Voltage	9.57	1.08	460	0.91	1765	68	0.79	125	0.87
			Low Voltage			230	1.8		34	1.6		1.74
1/3	0.25	VA-63M	High Voltage	12.0	1.36	460	0.94	1755	78	0.87	125	0.87
			Low Voltage			230	1.9		34	1.7		1.74
1/2	0.4	VA-71M	High Voltage	19.3	2.18	460	1.3	1750	70	1.1	115	1.21
			Low Voltage			230	2.6		35	2.3		2.42
3/4	0.55	VA-90S	High Voltage	26.3	2.98	460	1.7	1765	62	1.5	145	1.54
			Low Voltage			230	3.3		31	2.9		3.08

Table 5.20c Three Phase, 575V, 60Hz, 1800 RPM Synchronous Speed, 10:1 Constant Torque Speed Range TEFC - CSA Approved

Motor Capacity		Frame Size	Full Load Torque		Voltage V	60 Hz Current Amp	Speed RPM	Voltage V	6 Hz Current Amp	Speed RPM	No Load Current @ 60 Hz
HP	kW		in-lbs	N-m							
1/8	0.1	VA-63S	4.77	0.54	575	0.4	1770	85	0.3	130	0.4
1/4	0.2	VA-63M	9.57	1.08	575	0.7	1765	77	0.5	85	0.62
1/3	0.25	VA-63M	12.0	1.36	575	0.7	1755	95	0.7	120	0.62
1/2	0.4	VA-71M	19.4	2.19	575	0.94	1745	88	0.86	110	0.86
3/4	0.55	VA-90S	26.3	2.98	575	1.3	1765	76	1.1	140	0.98

Cyclo® HBB

Technical Information

Motor Performance Data - Small kW CE Motor, 50Hz Operation

Table 5.21a IE1 Three Phase, 220/380V, 50Hz, 1500 RPM Synchronous Speed, TEFC - CE

(Not for EU or UK)

Motor Capacity		Frame Size	Full Load (A)			Current				Starting Torque % of FL	Breakdown Torque % of FL	Nominal Efficiency %	Power Factor %	NEMA Code Letter
HP	kW		Rated RPM	Torque		Full Load		No Load % of FL	Starting % of FL					
				in-lbs	N-m	220V	380V							
1/8**	0.1	V-63S	1400	6.03	0.682	0.6	0.35	78.3	371	230	226	63.3	69.1	H
1/4	0.2	V-63M	1390	12.2	1.37	1.05	0.61	71.5	361	206	206	67.6	73.7	F
1/3	0.25	V-63M	1360	15.5	1.75	1.22	0.71	61.4	338	195	181	69.1	77.8	E
1/2	0.4	V-71M	1410	24.0	2.71	2.06	1.19	68.3	353	201	204	69.7	73.5	F
3/4	0.55	V-80S	1400	33.2	3.75	2.45	1.42	58.5	373	206	196	73.4	80.2	E

** 1/8 HP is TENV

Table 5.21b IE1 Three Phase, 230/400V, 50Hz, 1500 RPM Synchronous Speed, TEFC - CE

(Not for EU or UK)

Motor Capacity		Frame Size	Full Load (A)			Current				Starting Torque % of FL	Breakdown Torque % of FL	Nominal Efficiency %	Power Factor %	NEMA Code Letter
HP	kW		Rated RPM	Torque		Full Load		No Load % of FL	Starting % of FL					
				in-lbs	N-m	230V	400V							
1/8**	0.1	V-63S	1420	5.95	0.672	0.62	0.36	83.6	361	261	255	62.1	64.9	H
1/4	0.2	V-63M	1410	12.0	1.35	1.08	0.62	77.3	371	236	233	67.1	69.5	G
1/3	0.25	V-63M	1380	15.3	1.73	1.22	0.7	68.4	371	225	205	69.4	74.2	F
1/2	0.4	V-71M	1420	23.8	2.69	2.13	1.23	75.6	366	229	229	68.5	68.7	G
3/4	0.55	V-80S	1410	32.9	3.72	2.45	1.41	65.2	390	225	219	73.6	76.7	F

** 1/8 HP is TENV

Table 5.21c IE1 Three Phase, 240/415V, 50Hz, 1500 RPM Synchronous Speed, TEFC - CE

(Not for EU or UK)

Motor Capacity		Frame Size	Full Load (A)			Current				Starting Torque % of FL	Breakdown Torque % of FL	Nominal Efficiency %	Power Factor %	NEMA Code Letter
HP	kW		Rated RPM	Torque		Full Load		No Load % of FL	Starting % of FL					
				in-lbs	N-m	240V	415V							
1/8**	0.1	V-63S	1420	5.95	0.672	0.65	0.37	88.1	378	286	277	60.9	60.9	J
1/4	0.2	V-63M	1410	12.0	1.35	1.1	0.64	80.9	375	260	253	66.4	65.7	H
1/3	0.25	V-63M	1390	15.2	1.72	1.23	0.71	73.0	380	247	223	69.5	70.6	G
1/2	0.4	V-71M	1430	23.6	2.67	2.23	1.29	80.6	364	250	247	67.0	64.4	H
3/4	0.55	V-80S	1420	32.7	3.7	2.46	1.43	70.6	413	248	237	73.6	73.1	G

** 1/8 HP is TENV

Table 5.21d IE3 Three Phase, 230/400V, 50Hz, 1500 RPM Synchronous Speed, 6 lead, CE Marked, TEFC

(for EU or UK)

Motor Capacity		Frame Size	Full Load Ratings							Current as % Full Load		Torque as % of Full Load	
HP	kW		Current		RPM	Torque		Nominal Efficiency	Power Factor	No Load	Starting	Starting	Breakdown
			230V	400V		N-m	in-lbs						
1/8**	0.1**	V-63S	0.62	0.35	1420	0.672	5.95	62.1	0.65	83.6	361	261	255
1/8	0.12	VA-63S	0.7	0.41	1430	0.8	7.08	72.5	0.59	84.3	571	283	346
1/4	0.2	VA-63M	1.08	0.63	1410	1.35	11.95	76.5	0.60	77.8	565	277	331
1/3	0.25	VA-63M	1.19	0.69	1400	1.71	15.13	76.1	0.69	70.6	513	219	262
1/2	0.4	VA-71M	1.86	1.08	1420	2.68	23.72	79.1	0.68	72.6	559	311	362
3/4	0.55	N-80S	2.31	1.33	1430	3.66	32.39	83.5	0.71	36.4	647	293	365

** 0.1 kW (1/8 HP) is TENV and IE1

Cyclo® HBB

Technical Information

Motor continued

Motor Performance Data - EP.NA Motor, 60Hz Operation

Table 5.22 Three Phase, 230/460v, 60Hz, 1800 RPM Synchronous Speed, TEFC

Motor Capacity		Frame Size	Full Load			Current (A)				Starting Torque % of FL	Breakdown Torque % of FL	Nominal Efficiency %	Power Factor %	NEMA Code Letter
HP	kW		Rated RPM	Torque		Full Load		No Load % of FL	Starting % of FL					
				in-lbs	N-m	230V	460V							
1	0.75	N-80M	1730	36.6	4.14	3.06	1.53	62.0	692	343	403	85.5	72.0	K
1.5	1.1	N-90S	1730	53.7	6.07	4.15	2.08	52.1	659	277	341	86.5	76.5	J
2	1.5	N-90L	1730	73.2	8.28	5.61	2.80	52.7	694	284	356	86.5	77.2	J
3	2.2	N-100L	1740	107	12.1	7.66	3.83	47.6	824	317	389	89.5	80.7	K
5	3.7	N-112M	1750	179	20.2	12.3	6.17	44.5	821	244	379	89.5	83.9	K
7.5	5.5	N-132S	1760	264	29.8	17.8	8.90	42.9	1000	290	461	91.7	84.2	L
10	7.5	N-132M	1760	360	40.7	24.4	12.2	36.1	606	193	277	91.7	84.1	G
15	11	N-160M	1770	525	59.3	38.4	19.2	48.0	736	274	369	92.4	77.8	J
20	15	N-160L	1770	716	80.9	47.7	23.8	36.5	828	227	351	93.0	85.0	J
25	18.5	N-180MS	1780	878	99.2	56.9	28.5	31.7	805	245	308	93.6	86.4	J
30	22	N-180M	1780	1040	118	67.4	33.7	28.8	673	206	258	93.6	87.1	G
40	30	N-180L	1780	1420	161	91.6	45.8	29.5	792	242	295	94.1	87.0	J

Table 5.23 Three Phase, 240/480V, 60Hz, 1800 RPM Synchronous Speed, TEFC

Motor Capacity		Frame Size	Full Load			Current (A)				Starting Torque % of FL	Breakdown Torque % of FL	Nominal Efficiency %	Power Factor %	NEMA Code Letter
HP	kW		Rated RPM	Torque		Full Load		No Load % of FL	Starting % of FL					
				in-lbs	N-m	240V	480V							
1	0.75	N-80M	1740	36.4	4.12	3.05	1.52	66.2	723	380	439	85.5	69.2	L
1.5	1.1	N-90S	1740	53.4	6.04	4.09	2.05	56.6	704	310	375	86.5	74.1	J
2	1.5	N-90L	1730	73.2	8.28	5.54	2.77	57.8	722	316	387	86.5	74.5	K
3	2.2	N-100L	1750	106	12.0	7.53	3.77	52.0	911	352	446	89.5	78.4	L
5	3.7	N-112M	1760	178	20.1	12.1	6.06	49.3	886	268	421	89.5	81.7	K
7.5	5.5	N-132S	1760	264	29.8	17.5	8.76	47.6	1060	321	506	91.7	82.0	M
10	7.5	N-132M	1760	360	40.7	23.8	11.9	40.3	652	212	308	91.7	82.2	H
15	11	N-160M	1770	525	59.3	38.7	19.3	54.0	760	305	405	92.4	74.0	K
20	15	N-160L	1770	716	80.9	46.5	23.2	41.0	893	251	387	93.0	83.3	K
25	18.5	N-180MS	1780	878	99.2	55.1	27.6	35.2	881	268	340	93.6	85.3	K
30	22	N-180M	1780	1040	118	64.9	32.4	29.9	748	224	285	93.6	86.5	H
40	30	N-180L	1780	1420	161	88.8	44.4	33.3	867	266	326	94.1	85.9	J

Motor Performance Data - EP.NA Motor, 60Hz Operation (continued)

Table 5.24 Three Phase, 575V, 60Hz, 1800 RPM Synchronous Speed, TEFC

Motor Capacity		Frame Size	Full Load			Current (A)			Starting Torque % of FL	Breakdown Torque % of FL	Nominal Efficiency %	Power Factor %	NEMA Code Letter
HP	kW		Rated RPM	Torque		Full Load 575V	No Load % of FL	Starting % of FL					
				in-lbs	N-m								
1	0.75	N-80M	1740	36.4	4.12	1.36	72.7	768	430	500	85.5	64.4	M
1.5	1.1	N-90S	1740	53.4	6.04	1.69	57.8	743	313	386	86.5	74.5	K
2	1.5	N-90L	1730	73.2	8.28	2.22	52.3	685	272	341	86.5	77.9	J
3	2.2	N-100L	1740	107	12.1	3.05	47.2	839	322	404	89.5	80.8	K
5	3.7	N-112M	1750	179	20.2	4.86	42.0	798	230	355	89.5	84.9	J
7.5	5.5	N-132S	1760	264	29.8	7.12	42.5	957	263	429	91.7	84.7	L
10	7.5	N-132M	1760	360	40.7	10.1	43.9	704	230	332	91.7	81.3	H
15	11	N-160M	1760	528	59.7	14.5	41.7	710	237	331	92.4	82.3	H
20	15	N-160L	1770	716	80.9	19.4	41.1	915	257	396	93.0	83.3	K
25	18.5	N-180MS	1780	878	99.2	22.8	35.2	916	276	350	93.6	86.1	K
30	22	N-180M	1780	1040	118	26.8	29.9	779	230	293	93.6	87.2	H
40	30	N-180L	1780	1420	161	37.0	31.5	857	263	321	94.1	86.1	J

Motor continued

Motor Performance Data - IE3 CE Motor, 50Hz Operation

Table 5.25 Three Phase, 220/380V, 50Hz, 1500 RPM Synchronous Speed, TEFC

Motor Capacity		Frame Size	Full Load			Current (A)				Starting Torque % of FL	Breakdown Torque % of FL	Nominal Efficiency %	Power Factor %	NEMA Code Letter
HP	kW		Rated RPM	Torque		Full Load		No Load % of FL	Starting % of FL					
				in-lbs	N-m	220V	380V							
1	0.75	N-80M	1430	44.3	5.01	3.46	2.00	69.5	608	383	402	84.7	67.9	K
1.5	1.1	N-90S	1430	65.0	7.35	4.49	2.59	57.1	637	296	343	85.4	75.1	J
2	1.5	N-90L	1420	89.2	10.1	6.10	3.52	57.1	607	304	338	85.4	75.5	H
3	2.2	N-100L	1440	129	14.6	8.58	4.96	54.8	796	344	418	88.6	78.0	K
4	3.0	N-112S	1430	177	20.0	11.3	6.50	48.1	712	316	365	87.7	80.8	J
5	3.7	N-112M	1460	214	24.2	13.5	7.80	50.7	777	266	378	89.6	81.2	J
5.5	4.0	N-112M	1450	233	26.3	14.4	8.30	47.7	730	266	378	88.9	82.9	J
7.5	5.5	N-132S	1460	318	36.0	-	11.5	42.0	950	316	471	90.6	80.7	L
10	7.5	N-132M	1460	434	49.1	-	15.8	47.2	620	213	315	90.8	79.6	H
15	11	N-160M	1460	636	71.9	-	22.3	40.4	578	200	283	91.4	81.6	G
20	15	N-160L	1470	862	97.4	-	30.5	45.2	649	230	304	92.6	80.6	H
25	18.5	N-180MS	1480	1060	119	-	35.6	38.8	772	245	338	94.0	83.5	J
30	22	N-180M	1480	1260	142	-	41.9	32.9	656	206	284	93.5	85.4	G
40	30	N-180L	1480	1710	194	-	58.9	41.4	631	239	344	94.3	82.6	H

Table 5.26 Three Phase, 230/400V, 50Hz, 1500 RPM Synchronous Speed, TEFC

Motor Capacity		Frame Size	Full Load			Current (A)				Starting Torque % of FL	Breakdown Torque % of FL	Nominal Efficiency %	Power Factor %	NEMA Code Letter
HP	kW		Rated RPM	Torque		Full Load		No Load % of FL	Starting % of FL					
				in-lbs	N-m	230V	400V							
1	0.75	N-80M	1440	44.0	4.97	3.54	2.05	75.8	643	423	446	84.6	62.7	L
1.5	1.1	N-90S	1440	64.5	7.29	4.50	2.60	64.4	672	336	387	85.6	71.1	K
2	1.5	N-90L	1430	88.6	10.0	6.17	3.56	65.3	631	338	375	85.8	72.3	J
3	2.2	N-100L	1450	128	14.5	8.56	4.95	63.3	839	382	465	88.7	74.1	L
4	3.0	N-112S	1440	176	19.9	11.2	6.45	56.0	767	352	419	87.9	76.9	K
5	3.7	N-112M	1460	214	24.2	13.7	7.90	58.8	805	294	420	89.0	77.5	K
5.5	4.0	N-112M	1460	231	26.2	14.4	8.30	56.0	768	273	388	89.1	78.8	K
7.5	5.5	N-132S	1460	318	36.0	-	11.6	59.5	985	351	524	90.6	76.2	M
10	7.5	N-132M	1460	434	49.1	-	16.0	54.5	739	206	350	91.2	75.5	K
15	11	N-160M	1470	632	71.5	-	22.2	61.2	714	257	378	91.5	73.0	J
20	15	N-160L	1480	856	96.8	-	30.6	53.3	681	256	338	92.5	76.3	J
25	18.5	N-180MS	1480	1060	119	-	35.4	46.0	817	272	375	93.9	80.1	K
30	22	N-180M	1480	1260	142	-	40.9	39.9	707	227	314	93.8	82.7	H
40	30	N-180L	1480	1710	194	-	59.1	49.7	767	265	382	94.0	78.2	J

Cyclo® HBB
Technical Information

Motor Performance Data - IE3 CE Motor, 50Hz Operation (continued)

Table 5.27 Three Phase, 240/415V, 50Hz, 1500 RPM Synchronous Speed, TEFC

Motor Capacity		Frame Size	Full Load			Current (A)				Starting Torque % of FL	Breakdown Torque % of FL	Nominal Efficiency %	Power Factor %	NEMA Code Letter
HP	kW		Rated RPM	Torque		Full Load		No Load % of FL	Starting % of FL					
				in-lbs	N-m	240V	415V							
1	0.75	N-80M	1450	43.7	4.94	3.65	2.11	80.1	629	461	484	84.1	59.4	L
1.5	1.1	N-90S	1440	64.5	7.29	4.57	2.64	69.7	688	368	422	85.5	67.4	K
2	1.5	N-90L	1440	88.0	9.95	6.29	3.63	72.2	642	366	406	85.4	67.3	K
3	2.2	N-100L	1450	128	14.5	8.83	5.10	69.3	844	412	502	88.3	69.3	M
4	3.0	N-112S	1440	176	19.9	11.3	6.55	62.5	785	387	458	87.9	73.2	L
5	3.7	N-112M	1460	214	24.2	13.9	8.00	65.6	827	319	453	89.2	72.7	L
5.5	4.0	N-112M	1460	231	26.2	14.5	8.35	62.9	792	294	418	89.0	74.8	K
7.5	5.5	N-132S	1470	316	35.7	-	11.9	67.1	1000	378	564	90.2	72.0	N
10	7.5	N-132M	1470	431	48.7	-	16.2	61.4	660	254	378	90.6	71.1	J
15	11	N-160M	1470	632	71.5	-	22.4	53.2	648	249	354	91.6	74.6	H
20	15	N-160L	1480	856	96.8	-	31.2	59.9	693	275	364	92.2	72.3	J
25	18.5	N-180MS	1490	1050	119	-	35.7	52.4	840	292	404	93.8	76.7	K
30	22	N-180M	1480	1260	142	-	40.8	45.8	735	245	339	93.6	80.2	J
40	30	N-180L	1480	1710	194	-	60.2	55.6	781	285	411	93.6	74.2	K

Motor continued

Motor Selection Considerations for Inverter (VFD) Operation

Benefits:

Operating a three-phase AC Motor with an Inverter (Variable Frequency Drive – VFD) brings benefits to the design of a process control system:

- Extending a motor's acceleration time (soft starting) can greatly reduce motor starting current levels. Inrush current is limited typically to 150% of a motor's ampere ratings.
- Controlled and extended acceleration and deceleration rates reduce or eliminate the stress of high torque demands on the motor, reducer and driven load.
- Motor speed can be infinitely adjusted electronically to operate the process at the optimum speed.
- Full-rated motor torque levels can be applied to the load over as much as a 10:1 speed range (6 to 60 Hz, approximately 180 to 1800 RPM motor shaft speed). *(See note on next page about Constant Torque Speed Range)*
- Overspeed operation: within the operating limits of the motor, reducer and driven load, motor speed range can be extended beyond 60 Hz (1800 RPM). *(See note on next page about Constant Horsepower Speed Range)*
- Regulation of motor speed and/or torque without additional feedback devices.
- A properly sized and adjusted Sensorless Flux Vector AC drive can regulate motor shaft speed to almost eliminate motor slip over the motor's entire loading range.
- Electronic programmable motor torque limiting.
- Electronic overload and short circuit protection for the motor.
- Electronic Reversing: upon command, a VFD will follow preprogrammed deceleration rate to stop motor and then follow acceleration rate to bring motor to commanded speed in reverse direction. No additional power or mechanical components needed to reverse the motor.
- Motor braking (up to 150% of motor rated torque level with optional VFD components).
NOTE: VFDs do not provide HOLDING brake capability. VFDs can be used to sequence a motor-mounted holding brake.
- Many VFDs include basic process control functions and easily interface with Programmable Logic Controllers for more advance process control schemes.
- Serial communication capability for remote monitoring of motor, VFD and process status.
- Within a small limited HP range, VFDs can be selected to power a three-phase 230V motor from a single phase 240V power feed.

Constant Torque Operation:

For most gearmotor applications, a constant-torque rated VFD is required.

Constant-torque rated VFDs carry various manufacturer designations:

- Constant Torque, Heavy Duty or Normal Duty.

All constant-torque rated VFDs carry a 60-second ampere overload capability level of 150% of the VFD's continuous output ampere rating.

VFDs that offer a 110% or 120% 60-second ampere overload capability are designed for variable-torque type loads like fans and pumps with propellers and impellers and are most likely undersized for gearmotor applications.

When a VFD applies power to a motor, it simultaneously varies both the applied motor voltage level (amplitude) and the motor frequency (Hz) so that the torque delivered at the motor shaft can be held constant from a motor's base speed (typically 60 Hz) down to below 20 Hz.

The lower frequency limit is dependent on the design complexity of the VFD:

Basic V/Hz control (6 Hz), Sensorless Vector control (0.6 Hz), full Flux Vector control (0.06 Hz).

To achieve the Vector levels of motor control, the VFD must control only one motor, the VFD and motor must be closely matched in power ratings and the VFD must be properly adjusted, perhaps even "tuned" to the motor.

Most electrical motors are not designed to operate continuously at such low frequencies.

(See note on next page about Constant Torque Speed Range)

Motor Selection Considerations for Inverter (VFD) Operation (cont.)

Constant Horsepower (CHP) Operation:

It may be possible to configure a VFD to operate a motor at speeds beyond the motor's base frequency (typically 60 Hz – 1800 RPM).

To avoid unsafe and unreliable operation, never power a motor, reducer or a driven load beyond the manufacturer's maximum safe operating speed.

Consult Sumitomo factory for the HBB reducer maximum operating speed rating.
Consult the manufacturer of the driven load for its maximum operating speed rating.

A motor's full-load power rating is the product of its full-load torque rating and its base speed rating.
A motor's power rating does not increase when it is operated above its base speed.

Operation above a motor's base frequency is called Constant Horsepower (CHP) operation.
When a motor is operated above its base frequency, its output torque capability drops as its frequency is increased.

Constant Torque Speed Range (CTSR):

Most motors are not designed to operate for prolonged periods of time at low speed (typically below 20 Hz).

Most motors (i.e TEFC) depend upon a motor shaft-mounted fan for ventilation.

When the motor is operating at low speed, this motor shaft-mounted fan does not provide sufficient air movement to keep the motor's internal temperature within proper operating limits.

Operating a motor continuously beyond its CTSR can result in premature motor failure.
Be sure to properly configure the VFD's motor overload protection to match the motor type.

Motors listed for control by a VFD at low speed have been specifically designed to dissipate the heat through means other than the motor shaft-mounted fan.

A motor's ability to operate continuously at low speed is defined by its CTSR or Constant Torque Speed Range.

Examples of a CTSR rating are: 4:1, 6:1, 10:1.

A motor with a CTSR rating of 4:1 can operate continuously at 15 Hz (60 Hz / 4 = 15 Hz).

A motor with a CTSR rating of 10:1 can operate continuously at 6 Hz (60 Hz / 10 = 6 Hz).

See "Constant Torque Speed Ranges: Gearmotors" on page 3.8 for the Sumitomo motor constant torque speed rating (CTSR).

Consult the instructional material supplied with the VFD for additional important information.

Motor continued

Standard Wiring Diagrams

Illustrated below are the wiring diagrams for our standard motors. For additional information please refer to the motor name plate. Due to changes in design features, this diagram may not always agree with that on the motor. If different, the motor diagram found inside the conduit box cover should be used.

Three-Phase Fractional and EP.NA Motor

Table 5.28 Wiring Configuration for 230/460V, 60Hz and 575V, 60Hz by EP.NA Motor

Motor HP x P	230/460V, 60Hz			575V, 60Hz		
	Internal	No. of Leads	Diagram	Internal	No. of Leads	Diagram
1/8 x 4	WYE	9	9-Lead WYE	WYE	3	3-Lead
1/4 x 4						
1/3 x 4						
1/2 x 4						
3/4 x 4						
1 x 4						
1.5 x 4						
2 x 4						
3 x 4						
5 x 4						
7.5 x 4	DELTA	9	9-Lead DELTA	DELTA	3	3-Lead
10 x 4						
15 x 4						
20 x 4						
25 x 4						
30 x 4						
40 x 4						

Figure 5.9 9-Lead - WYE

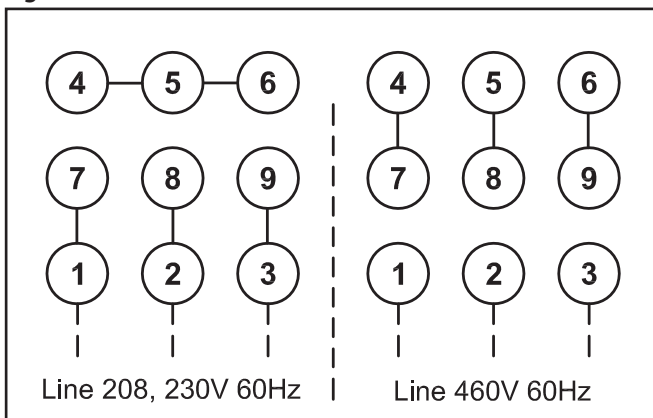

Figure 5.10 9-Lead - DELTA

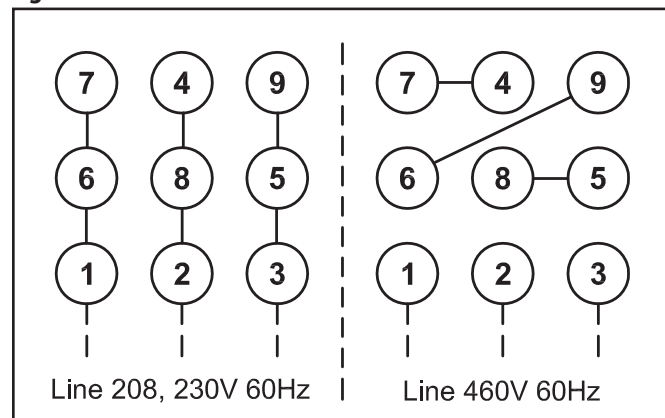
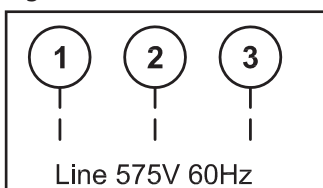

Figure 5.11 3-Lead - SINGLE



Three-Phase IE3 CE Motors

Table 5.29 Wiring Configuration by IE3 CE Motor

Motor kW x P	Voltage Configuration	Wiring Diagram
0.1 x 4	220/380V, 50Hz Three Phase	DELTA-WYE
0.2 x 4		
0.25 x 4		
0.4 x 4		
0.55 x 4		
.75 x 4		
1.1 x 4		
1.5 x 4		
2.2 x 4		
3.0 x 4		
3.7 x 4	380V, 50Hz Three Phase	WYE-Start DELTA-Run
5.5 x 4		
7.5 x 4		
11 x 4		
15 x 4		
18.5 x 4		
22 x 4		
30 x 4		

Figure 5.12 DELTA-WYE Diagram

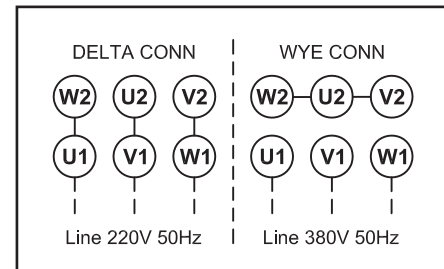
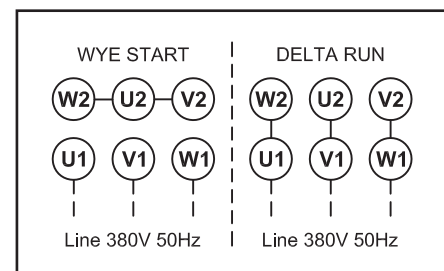

Figure 5.13 WYE-Start DELTA-Run Diagram



Motor continued

Motor Thermal Rating for Cyclic Applications

Motors operated across the line with frequent starts and stops will generate excess heat from high starting current. The capacity for the motor to handle this extra heating will depend on the combination of strating frequency, the load inertia, and time duty. Calculate the C x Z value from the formulas below for intertial factor (C) and starts per hour (Z) and compare the C x Z results against the permissible values for the intergral motor ratings in the Motor Thermal Rating Table

Table 5.30 Motor Thermal Rating Table

Motor Power HP (kW)	Allowable C x Z				Motor Inertia lb-in ² (kg-m ²)	
	below 35% ED ^[1]	35% ~ 50% ED ^[1]	50% ~ 80% ED ^[1]	80% ~ 100% ED ^[1]	Standard	with Brake
1/8 (0.1)	3200	3000	2000	1200	1.11 (0.000325)	1.2 (0.00035)
1/4 (0.2)	2200	2800	2800	2500	1.71 (0.0005)	1.88 (0.00055)
1/3 (0.25)	2200	2800	2800	2500	1.71 (0.0005)	1.88 (0.00055)
1/2 (0.4)	1800	2200	1500	1500	2.22 (0.00065)	2.31 (0.000675)
3/4 (0.55)	1800	2200	1500	1500	3.45 (0.00101)	3.79 (0.00111)
1 (0.75)	1400	1400	800	500	8.03 (0.00235)	8.82 (0.00258)
1.5 (1.1)	1400	1400	800	500	11.5 (0.00337)	13.5 (0.00396)
2 (1.5)	1200	1200	500	400	13.4 (0.00391)	15.4 (0.0045)
3 (2.2)	1000	900	400	200	30.1 (0.0088)	33.4 (0.00978)
5 (3.7)	800	800	800	700	66.3 (0.0194)	71.4 (0.0209)
7.5 (5.5)	300	300	200	150	99.4 (0.0291)	105 (0.0306)
10 (7.5)	400	350	300	300	140 (0.0409)	154 (0.045)
15 (11)	200	200	150	150	192 (0.0561)	206 (0.0602)
20 (15)	100	90	78	68	340 (0.0995)	393 (0.115)
25 (18.5)	75	65	55	50	875 (0.256)	926 (0.271)
30 (22)	75	65	55	50	875 (0.256)	926 (0.271)
40 (30)	55	40	17	10	1110 (0.326)	1170 (0.342)

Note: [1] % ED = Duty Cycle.

The calculated C x Z value (steps 1 – 3 outlined below) should be less than the allowable value listed in Motor Thermal Rating table above.

1. Obtain the C value:

$$C = \frac{I_M + I_L}{I_M}$$

I_M = Moment of Inertia of the Motor.
 I_L = Moment of Inertia of the Load as seem from the motor shaft.

(c) Calculate Z by adding Z_r to Z_i by the following formula.

$$Z = Z_r + \frac{1}{2} \cdot Z_i = \frac{3600}{t_a + t_b} \cdot \left(nr + \frac{1}{2} ni \right) \text{ (times/hour)}$$

3. Calculate C x Z (the product of C and Z)

Use the value of C obtained in Step (1) and value of Z obtained in Step (2).

2. Obtain the Z value (number of starts per hour):

(a) Assume that one operating period consists of “on-time” t_a (sec.), “off-time” t_b (sec.) and the motor is started nr (times/cycle).

$$Z_r = \frac{3600 \cdot nr}{t_a + t_b} \text{ (times/hour)}$$

(b) When inching, ni (times/cycle) is included in 1 cycling (t_a+t_b), the number of inching times per hour Z_i, is then included in the number of starts.

$$Z_i = \frac{3600 \cdot ni}{t_a + t_b} \text{ (times/hour)}$$

4. Obtain the duty cycle %ED and compare calculated C x Z in the appropriate column from Motor Thermal Rating Table.

$$\%ED = \frac{t_a}{t_a + t_b} \cdot 100$$

t_a = on-time
t_b = off-time

Brakemotor Characteristics

The brakemotor on Cyclo® HBB gearmotors operates with direct current supplied by a dual voltage rectifier for 230/460V, or single voltage rectifier/power module for other noted voltages. Rectifier or power module is mounted in the motor conduit box.

When used for outdoor installations, standard brakemotor must be protected by a cover. Such covers are available from the factory, please inquire when ordering.

Note: Advise the factory when ordering if you require brake torque greater or lesser than those shown as standard in the Brakemotor Characteristics table below.

Brake Characteristics

Table 5.31 Brake Characteristics - Standard torque, Delay Time, Work Capacity

Brake Model	Motor Capacity		Standard Braking Torque ft - lbs (N - m)	Braking Delay Time (sec)			Brake Work Capacity		
	HP x 4P	kW x 4P		Normal Braking Action		Fast Braking Action	Allowable E ₀ (J/min)	Gap Adjust (x 10 ⁷ J)	Total E ₁ (x 10 ⁷ J)
				Standard Wiring	Inverter Wiring ^[1]				
FB-01A1	1/8	0.1	0.7 (1.0)	0.15 ~ 0.2	0.08 ~ 0.12	0.015 ~ 0.02	1080	2.6	6.7
FB-02A1	1/8 ~ 1/3	0.1 ~ 0.25	1.4 (2.0)						
FB-05A1	1/4 ~ 1/2	0.2 ~ 0.4	2.9 (4.0)						
FB-1D	1/2	0.4	5.8 (7.5)	0.2 ~ 0.3	0.1 ~ 0.15	0.01 ~ 0.02	1620	7.0	33.1
FB-2D	3/4	0.55	11 (15)						
FB-3D	3/4	0.55	16 (22)						
FB-1E	1	0.75	5.5 (7.5)	0.25 ~ 0.45	0.15 ~ 0.25	0.01 ~ 0.03	2580	11.6	38.7
FB-1HE	1.5	1.1	8.0 (11)						
FB-2E	2	1.5	11 (15)						
FB-3E	3	2.2	16 (22)	0.75 ~ 0.95	0.4 ~ 0.5	0.02 ~ 0.04	5720	26.3	105.3
FB-5E	5	3.7	30 (40)						
FB-8E	7.5	5.5	40 (55)						
FB-10E	10	7.5	59 (80)	1.8 ~ 2.0	0.6 ~ 0.7	10800	110.2	551.1	
FB-15E	15	11	80 (110)						
FB-20	20	15	110 (150)	-	-	0.06 ~ 0.14 ^[2]	22440	191.6	1150
FB-30	25	18.5	140 (190)	-	-				
	30	22	160 (220)						
	40	30	150 (200)						

Notes: [1] Also applies to wiring where brake is powered separately from the motor leads.

[2] Values shown for 200V Class and 400V Class Brakes. Please consult factory for 575V Brakes.

Motor continued

Brake Characteristics

Table 5.32 Brake Maintenance - Brake Gap, Brake Lining Thickness

Brake Model	Brake Gap			Brake Lining Thickness	
	Spec. (Initial) inch (mm)	Limit inch (mm)	Adjustment Method	Spec. (Initial) inch (mm)	Limit inch (mm)
FB-01A1	0.008 ~ 0.014 (0.2 ~ 0.35)	0.020 (0.5)	Twist Detent	0.276 (7.0)	0.256 (6.5)
FB-02A1					
FB-05A1					
FB-1D	0.012 ~ 0.016 (0.3 ~ 0.4)	0.024 (0.60)	Shim	0.347 (8.8)	0.236 (6.0)
FB-2D		0.028 (0.70)			0.307 (7.8)
FB-3D					0.315 (8.0)
FB-1E	0.010 ~ 0.014 (0.25 ~ 0.35)	0.024 (0.60)	Shim	0.347 (8.8)	0.307 (7.8)
FB-1HE		0.030 (0.75)		0.355 (9.0)	0.315 (8.0)
FB-2E				0.034 (0.85)	0.410 (10.4)
FB-3E		0.040 (1.0)			0.394 (10.0)
FB-5E	0.014 ~ 0.018 (0.35 ~ 0.45)	0.047 (1.2)	Nut	0.433 (11.0)	0.276 (7.0)
FB-8E					
FB-10E		0.059 (1.5)		0.630 (16.0)	0.472 (12.0)
FB-15E					
FB-20	0.024 ~ 0.028 (0.6 ~ 0.7)	0.059 (1.5)	Nut	0.630 (16.0)	0.472 (12.0)
FB-30					

Brakemotor: Brake Current Rating

Table 5.33 Brake Current for Standard Fractional Motor and AF-Motor (AV)

Brake Model	230VAC, 60Hz			460VAC, 60Hz			575VAC, 60Hz		
	Vdc (V)	Idc (A)	Iac (A)	Vdc (V)	Idc (A)	Iac (A)	Vdc (V)	Idc (A)	Iac (A)
FB-01A1	207VDC Full Wave	0.05	0.06	207VDC Half Wave	0.05	0.04	259VDC Half Wave	0.05	0.03
FB-02A1		0.08	0.1		0.08	0.06		0.09	0.07
FB-05A1		0.1	0.1		0.1	0.1		0.1	0.1
FB-1D		0.2	0.2		0.2	0.2		0.2	0.2
FB-2D									
FB-3D									

Table 5.34 Brake Current for EP.NA Motor

Brake Model	230VAC, 50/60Hz			240VAC, 50/60Hz			460VAC, 50/60Hz			480VAC, 50/60Hz		
	Vdc (V)	Idc (A)	Iac (A)	Vdc (V)	Idc (A)	Iac (A)	Vdc (V)	Idc (A)	Iac (A)	Vdc (V)	Idc (A)	Iac (A)
FB-1E	207VDC Full Wave	0.1	0.1	216VDC Full Wave	0.1	0.1	207VDC Half Wave	0.1	0.1	216VDC Half Wave	0.1	0.1
FB-1HE		0.2	0.2		0.2	0.2		0.2	0.2		0.2	
FB-2E		0.2	0.2		0.2	0.2		0.3	0.2		0.2	
FB-3E		0.4	0.4		0.4	0.4		0.3	0.4		0.3	
FB-5E		0.4	0.4		0.5	0.5		0.4	0.3		0.4	
FB-8E												
FB-10E												
FB-15E												
FB-20	207VDC /104VDC Module ^[1]	2.0/1.0 ^[2]	2.0/0.8 ^[2]	216VDC /108VDC Module ^[2]	2.1/1.1 ^[2]	2.1/0.8 ^[2]	414VDC /207VDC Module ^[1]	1.0/0.5 ^[2]	1.0/0.4 ^[2]	432VDC /216VDC Module ^[1]	1.0/0.5 ^[2]	1.0/0.4 ^[2]

Table 5.35 Brake Current for EP.NA Motor 575V

Brake Model	575VAC, 50/60Hz		
	Vdc (V)	Idc (A)	Iac (A)
FB-1E	259VDC Half Wave	0.1	0.1
FB-1HE		0.2	0.2
FB-2E		0.2	0.2
FB-3E		0.4	0.3
FB-5E		0.5	0.4
FB-8E			
FB-10E			
FB-15E			
FB-20	259VDC Half Wave	0.4	0.3

Notes: [1] Power module type brake control generates two voltage levels--1) high excitation voltage for initial release, and 2) lower holding voltage.
 [2] 2 brake current values shown corresponding to the two voltage levels from power module--1) excitation current on initial power up, and 2) holding current.

Brake coil design will be specific to brake voltage specified at time of order. Check motor nameplate, to determine brake voltage rating.
 FB-20 and FB-30 Brake Coil and Power Module come in two voltage ranges--1) 200-240VAC, and 2) 380-480VAC.

Motor continued

Table 5.36 Brake Current for Fractional Motor CE Motor

Brake Model	220VAC, 50Hz			230VAC, 50Hz			380VAC, 50Hz			400VAC, 50Hz		
	Vdc (V)	Idc (A)	Iac (A)	Vdc (V)	Idc (A)	Iac (A)	Vdc (V)	Idc (A)	Iac (A)	Vdc (V)	Idc (A)	Iac (A)
FB-01A1	99VDC Half Wave	0.13	0.12	104VDC Half Wave	0.13	0.12	171VDC Half Wave	0.06	0.04	180VDC Half Wave	0.06	0.04
FB-02A1		0.2	0.2		0.2	0.2		0.08	0.07		0.08	0.07
FB-05A1		0.3	0.2		0.2	0.2		0.1	0.1		0.1	0.1
FB-1D												

Table 5.37 Brake Current for IE3 CE Motor

Brake Model	220VAC, 50Hz			230VAC, 50Hz			380VAC, 50Hz			400VAC, 50Hz		
	Vdc (V)	Idc (A)	Iac (A)	Vdc (V)	Idc (A)	Iac (A)	Vdc (V)	Idc (A)	Iac (A)	Vdc (V)	Idc (A)	Iac (A)
FB-1E	99VDC Half Wave	0.2	0.2	104VDC Half Wave	0.2	0.2	171VDC Half Wave	0.1	0.1	180VDC Half Wave	0.1	0.1
FB-1HE		0.5	0.4		0.5	0.4		0.2	0.2		0.2	0.2
FB-2E		0.6	0.5		0.6	0.5		0.3	0.2		0.3	0.2
FB-3E		1	0.7		1	0.8		0.4	0.3		0.4	0.3
FB-4E		1.1	0.9		1.2	0.9		0.5	0.4		0.5	0.4
FB-5E												
FB-8E												
FB-10E												
FB-15E												
FB-20	198VDC /99VDC Module ^[1]	2.0/1.0 ^[2]	2.0/0.8 ^[2]	207VDC /104VDC Module ^[1]	2.0/1.0 ^[2]	2.0/0.8 ^[2]	342VDC /171VDC Module ^[1]	0.8/0.4 ^[2]	0.8/0.3 ^[2]	360VDC /180VDC Module ^[1]	0.9/0.5 ^[2]	0.9/0.4 ^[2]
FB-30												

Cyclo® HBB

Technical
Information

Notes: [1] Power module type brake control generates two voltage levels--1) high excitation voltage for initial release, and 2) lower holding voltage.

[2] 2 brake current values shown corresponding to the two voltage levels from power module--1) excitation current on initial power up, and 2) holding current.

Brake coil design will be specific to brake voltage specified at time of order. Check motor nameplate, to determine brake voltage rating.

FB-20 and FB-30 Brake Coil and Power Module come in two voltage ranges--1) 200-240VAC, and 2) 380-480VAC.

Brakemotor: Optional Brake Torques

Table 5.38 Standard Brake Models

Brake Model	Motor Capacity			Motor Frame Size	Braking Torque ft-lbs (N-m)				
	Model	HP x 4P (ST)	HP x 4P (AV)		kW x 4P (ST)	Standard	Optional		
FB-01A1	1/8	-	0.1	V-63S	0.7 (1.0)	0.25 (0.34)	0.3 (0.4)	0.4 (0.54)	0.48 (0.65)
						0.6 (0.8)	0.7 (1.0)	1.0 (1.4)	-
FB-02A1	1/4 - 1/3	1/8	0.2 - 0.25	V-63M, VA-63S	1.4 (2.0)	0.48 (0.65)	0.6 (0.8)	0.7 (1.0)	1.0 (1.4)
						1.4 (2.0)	1.9 (2.6)	2.3 (3.1)	-
FB-05A1	1/2	1/4 - 1/3	0.37	V-71M VA-63M	2.9 (4.0)	0.7 (1.0)	1.0 (1.4)	1.4 (2.0)	-
						1.9 (2.6)	2.3 (3.1)	-	-
FB-1D	3/4	1/2	0.55	V-80S VA-71M	5.8 (7.5)	2.7 (3.7)	3.9 (5.3)	-	-
						4.6 (6.2)	6.9 (9.4)	7.7 (10)	-
FB-2D	-	3/4	-	VA-80S	11 (15)	3.6 (4.9)	4.3 (5.8)	5.1 (6.9)	7.2 (9.8)
						8.7 (12)	13 (18)	14 (19)	-
FB-1E	1	1	0.75	N-80M	5.5 (7.5)	2.2 (3.0)	3.0 (4.0)	4.0 (5.5)	7.4 (10)
FB-1HE	1.5	-	1.1	N-90S	8.0 (11)		3.7 (5.0)	5.5 (7.5)	11 (15)
FB-2E	2	1.5	1.5	N-90L	11 (15)	3.7 (5.0)	5.5 (7.5)	8.0 (11)	15 (20)
FB-3E	3	2	2.2	N-100L	16 (22)	4.4 (6.0)	7.4 (10)	11 (15)	22 (30)
FB-5E	5	3	3.7	N-112M	30 (40)	7.4 (10)	15 (20)	22 (30)	40 (55)
FB-8E	7.5	5	5.5	N-132S	40 (55)	15 (20)	22 (30)	30 (40)	53 (72)
FB-10E	10	7.5	7.5	M-132M	59 (80)	15 (20)	30 (40)	44 (66)	80 (110)
FB-15E	15	10	11	M-160M	80 (110)	29 (40)	44 (60)	59 (80)	110 (150)
FB-20	20	15 - 20	15	N-160L	110 (150)	44 (60)	63 (85)	74 (100)	89 (120)
						130 (175)	160 (220)	-	-
FB-30	25	25	18.5	N180MS	140 (190)	44 (60)	74 (100)	89 (120)	110 (150)
						130 (175)	-	-	-
	30	30	22	N-180M	160 (220)	63 (85)	89 (120)	110 (150)	130 (175)
	40	40	30	N-180L	150 (200)	74 (100)	120 (160)	-	-

ST - Standard Motor, AV - Inverter Motor

Cyclo® HBB

Technical Information

Motor continued

Brakemotor Standard Wiring Connection, EP.NA Motor

Models FB-01A1 through FB-15E, 230/460V, 60Hz or 575V, 60Hz (Fractional through 15 HP)

Normal Brake Action, 230V Brake

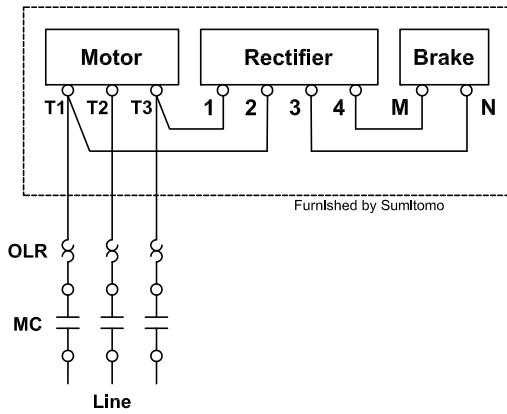

Fast Brake Action, 230V Brake

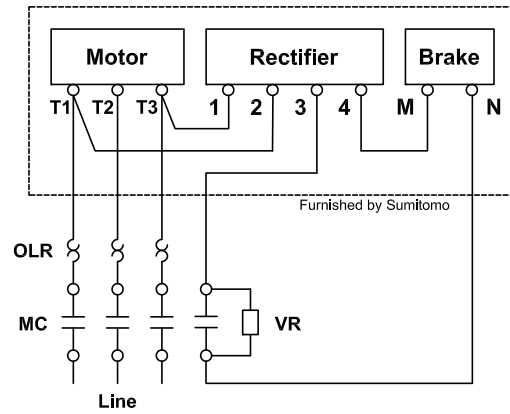

Normal Brake Action, 460V or 575V Brake

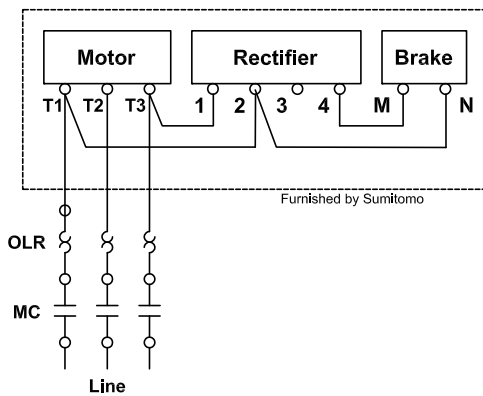

Fast Brake Action, 460V or 575V Brake

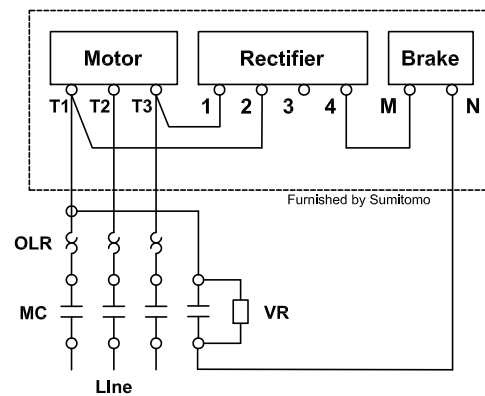

Cyclo® HBB

Technical Information

Key:
MC: Motor Contactor
OLR: Overload or Thermal Relay
VR: Varistor (protective device, refer to Varistor Specification Table)

Table 5.39 Varistor Specification Table

Operating Voltage		190-230V	380-460V	575V
Varistor Rated Voltage		AC260-300V	AC510V	AC604V
Varistor Voltage		430-470V	820V	1000V
Rated Watt	FB-01A1, 02A1, 05A1	Over 0.4W	Over 0.4W	Over 0.4W
	FB-1E, 1D	Over 0.6W	Over 0.6W	Over 0.4W
	FB-1HE, 2E, 2D, 3E	Over 1.5W	Over 1.5W	Over 0.6W
	FB-5E, 8E, 10E, 15E	Over 1.5W	Over 1.5W	Over 1.5W

Brakemotor Inverter Wiring Connection, EP.NA Motor

Models FB-01A1 through FB-15E, 230/460V, 60Hz or 575V, 60Hz

Normal Brake Action, 230V Brake

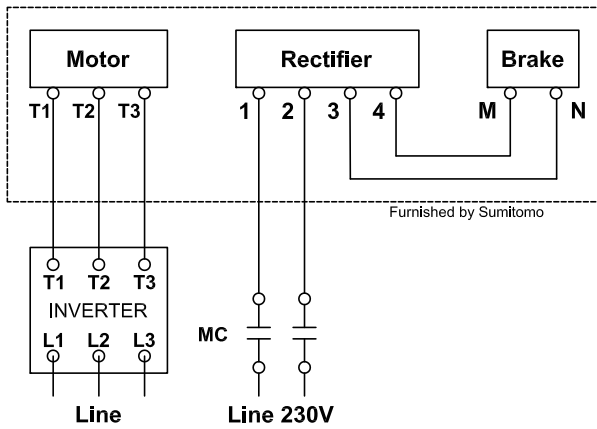

Fast Brake Action, 230V Brake

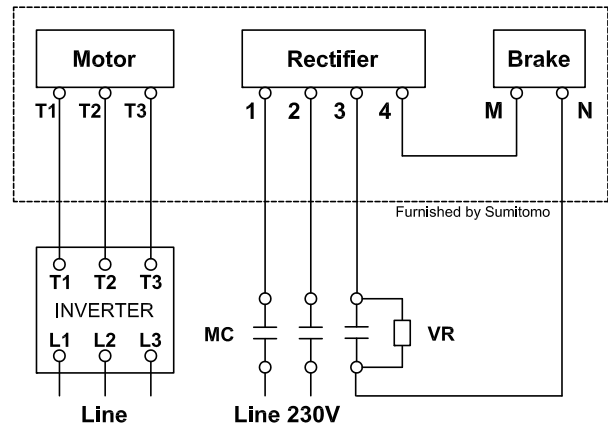

Normal Brake Action, 460V or 575V Brake

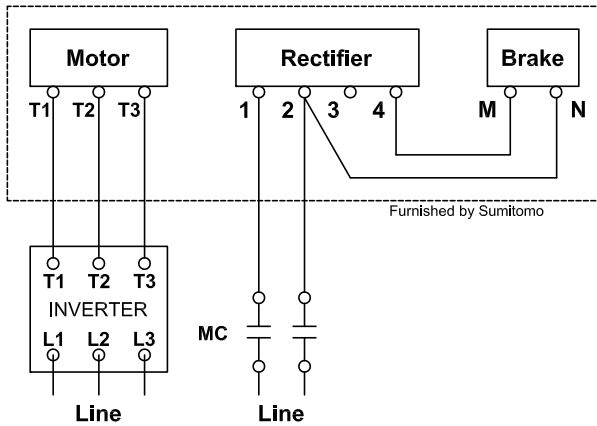

Fast Brake Action, 460V or 575V Brake

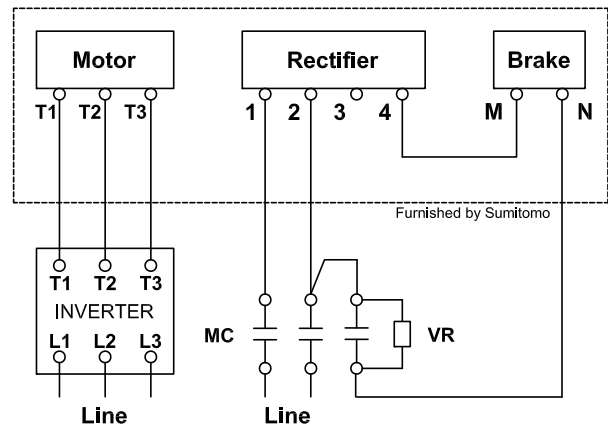

Key:

MC: Motor Contactor

OLR: Overload or Thermal Relay

VR: Varistor (protective device, refer to Varistor Specification Table)

Table 5.40 Varistor Specification Table

Operating Voltage		190-230V	380-460V	575V
Varistor Rated Voltage		AC260-300V	AC510V	AC604V
Varistor Voltage		430-470V	820V	1000V
Rated Watt	FB-01A1, 02A1, 05A1	Over 0.4W	Over 0.4W	Over 0.4W
	FB-1E, 1D	Over 0.6W	Over 0.6W	Over 0.4W
	FB-1HE, 2E, 2D, 3E	Over 1.5W	Over 1.5W	Over 0.6W
	FB-5E, 8E, 10E, 15E	Over 1.5W	Over 1.5W	Over 1.5W

Cyclo® HBB

Technical Information

Motor continued

Standard Wiring Connection for IE3 CE Motors

Models FB-01A1 through FB-5E, 220/380V, 50Hz

Normal Brake Action, 220V Motor, 220V Brake

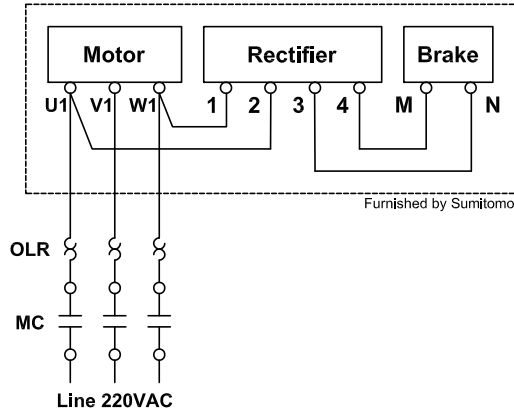

Fast Brake Action, 220V Motor, 220V Brake

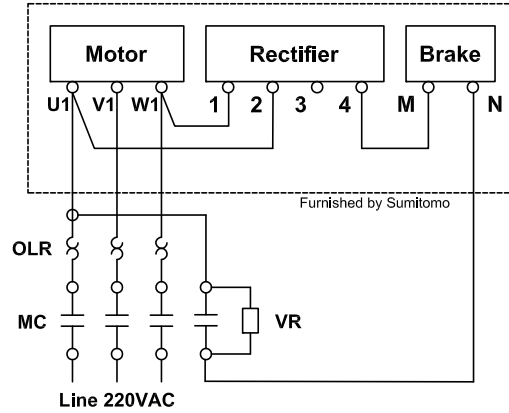

Normal Brake Action, 380V Motor, 220V Brake, Tapped

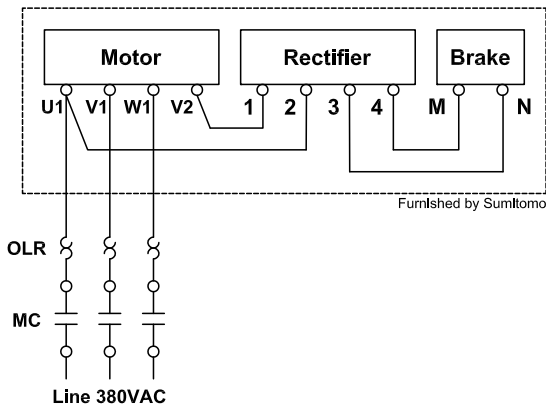

Fast Brake Action, 380V Motor, 220V Brake, Tapped

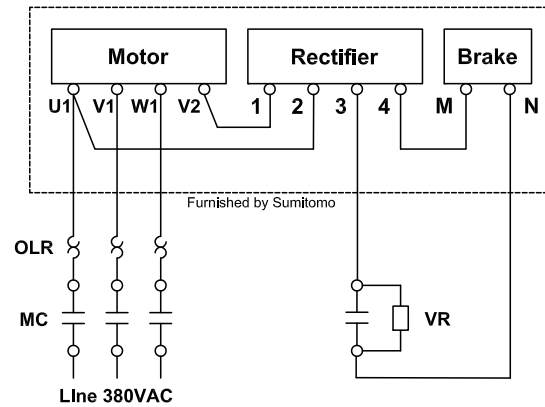

Normal Brake Action, 380V Motor, 220V Brake, Separated

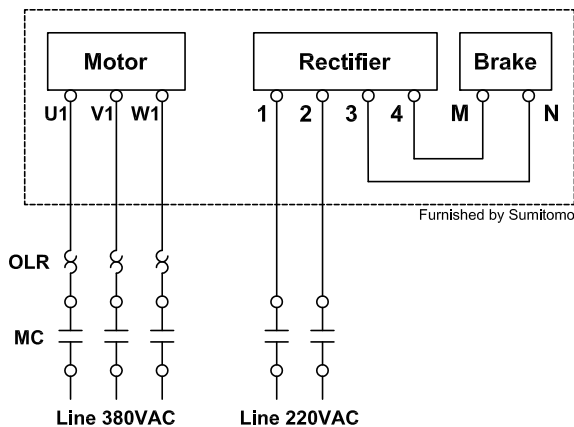

Fast Brake Action, 380V Motor, 220V Brake, Separated

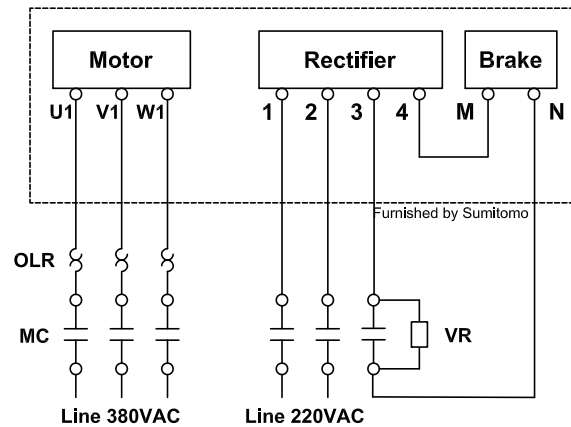

- Key:**
MC: Motor Contactor
OLR: Overload or Thermal Relay
MCB: Magnetic Circuit Breaker
VR: Varistor (protective device, refer to Varistor Specification Table on page 5.39)

Standard Wiring Connection for IE3 CE Motors (continued)

Models FB-8E through FB-15E, 380V, 50Hz

Normal Brake Action, 380V Motor, 380V Brake

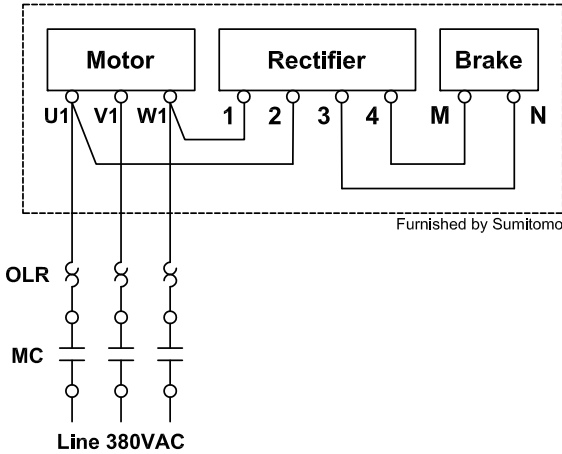

Fast Brake Action, 380V Motor, 380V Brake

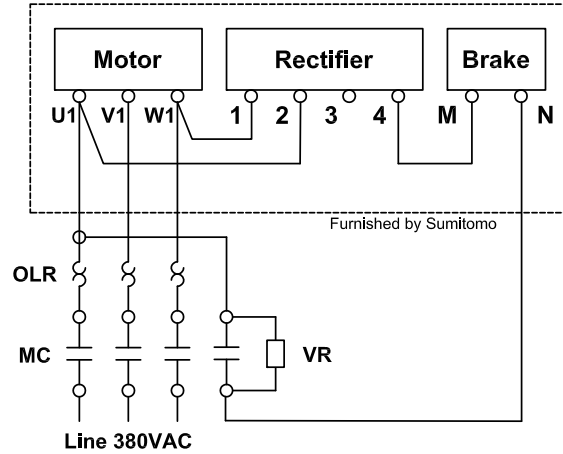

Models FB-01A1 through FB-15E with Inverter

Normal Brake Action

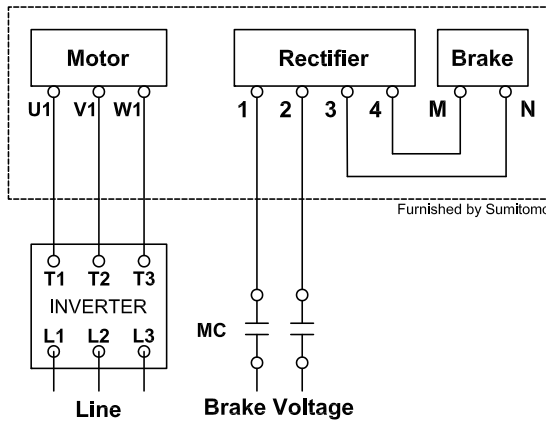

Fast Brake Action

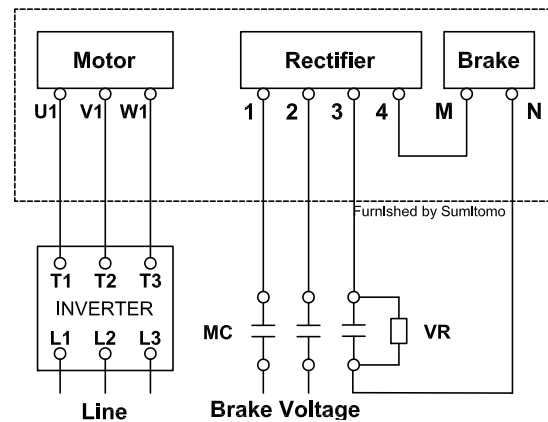

Key:

MC: Motor Contactor **OLR:** Overload or Thermal Relay **MCB:** Magnetic Circuit Breaker
VR: Varistor (protective device, refer to Varistor Specification Table)

Table 5.41 Standard CE Motor, Motor/Brake Voltage Table

Motor Power kW x 4P	Brake Model	Motor Voltage	Brake Voltage
0.75	FB-1E	220/380V, 50Hz	220V, 50Hz*
1.1	FB-2E		
1.5	FB-1HE		
2.2	FB-3E		
3.0	FB-4E		
3.7	FB-5E		
5.5	FB-8E	380V, 50Hz	380V, 50Hz
7.5	FB-10E		
11	FB-15E		

*Optional 380V 50Hz Brake Available

Table 5.42 Varistor Specification Table

Operating Voltage		190-230V	380-460V
Varistor Rated Voltage		AC260-300V	AC510V
Varistor Voltage		430-470V	820V
Rated Watt	FB-01A1, 02A1, 05A1	Over 0.4W	Over 0.4W
	FB-1E, 1D	Over 0.6W	Over 0.6W
	FB-1HE, 2E, 2D, 3E	Over 1.5W	Over 1.5W
	FB-5E, 2E, 2D, 3E	Over 1.5W	Over 1.5W

Cyclo® HBB

Technical Information

Motor continued

Wiring for Brake Models FB-20 / FB-30 - EP.NA Motor and IE3 CE Motor

FB-20 and FB-30 Brake Wiring, 480VAC or less

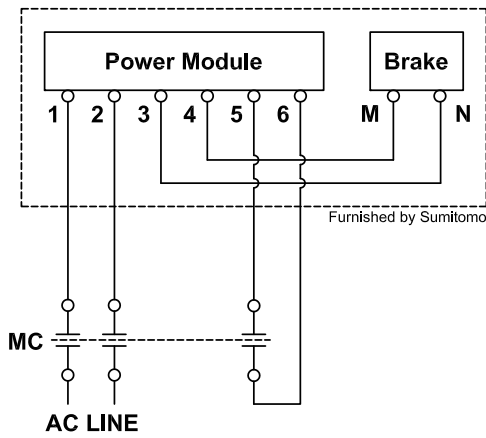

FB-20 and FB-30 Brake Wiring, 575VAC

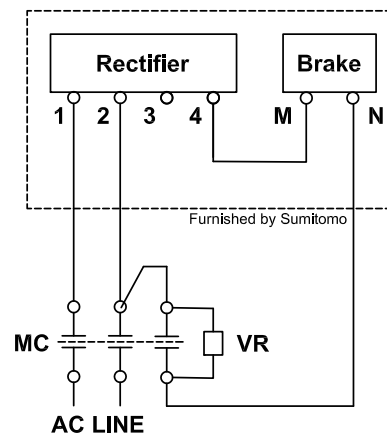

Key:

MC: Motor Contactor

VR: Varistor (protective device, refer to Varistor Specification Table)

Varistor Rated Voltage - AC604V

Varistor Rated Watts - Over 1.5W

*optional 380V 50Hz Brake Available

Brake Rectifiers and Brake Power Modules

Table 5.43a Brake Rectifiers for Fractional Motors

Brake Type	Motor Power HP x P	230V/460V Rectifier		575V Rectifier	
		Model Number	Part Number	Model Number	Part Number
FB-01A1	1/8 X 4	25FW-4FB3	EY477WW-01	10F-6FB3	EY498WW-01
FB-02A1	1/4 - 1/3 X 4				
FB-05A1	1/2 X 4				
FB-1D	3/4 X 4				
FB-2D	3/4 X 4				

Table 5.43b Brake Rectifiers for Fractional Motors

Brake Type	Motor Power kW x P	220V Rectifier	
		Model Number	Part Number
FB-01A1	0.1 X 4	10F-2FB2	MP983WW-01
FB-02A1	0.2 - 0.25 X 4		
FB-05A1	0.37 X 4		
FB-1D	0.55 X 4		

Table 5.43c Brake Rectifiers for EP.NA Motors up to 15 HP

Brake Type	Motor Power HP x P	230V/460V Rectifier		575V Rectifier	
		Model Number	Part Number	Model Number	Part Number
FB-1E	1 x 4	25FW-4FB3	EY477WW-01	10F-6FB3	EY498WW-01
FB-1HE	1.5 x 4				
FB-2E	2 x 4				
FB-3E	3 x 4				
FB-5E	5 x 4				
FB-8E	7.5 x 4				
FB-10E	10 x 4				
FB-15E	15 x 4				

Table 5.43d Brake Rectifiers for IE3 CE Motors up to 11 kW

Brake Type	Motor Power kW x P	220V Rectifier		380V Rectifier	
		Model Number	Part Number	Model Number	Part Number
FB-1E	0.75 x 4	10F-2FB2	MP983WW-01		
FB-1HE	1.1 x 4				
FB-2E	1.5 x 4				
FB-3E	2.2 x 4				
FB-4E	3.0 x 4				
FB-5E	3.7 x 4 4.0 x 4				
FB-8E	5.5 x 4			05F-4FB2	MP985WW-01
FB-10E	7.5 x 4				
FB-15E	11 x 4			15F-4FB1	EW397WW-01

Cyclo® HBB

Technical
Information

Table 5.44 Brake Rectifiers and Power Modules for EP.NA Motors and IE3 CE Motors (20-40 HP)(15-30 kW)

Brake Type	Motor (HP x P)	Motor Power (kW x P)	170 ~ 300VAC Module		380 ~ 480VAC Module	
			Model Number	Part Number	Model Number	Part Number
FB-20	20 x 4	15 x 4	13SR-2	EY570WW-01	10SR-4	MQ003WW-01
FB-30	25 x 4	18.5 x 4				
	30 x 4 40 x 4	22 x 4 30 x 4				

Warranty

Company warrants that (i) all new equipment and parts (collectively, "Equipment") sold by Company will conform to printed drawings and specification sheets issued by Company and (ii) are free of defects in material and workmanship for the time period shown in Table 1. The warranty period commences on the date of shipment of the Equipment by Company.

If, within the warranty period, Company receives from Buyer written notice of any alleged defect in any of the Equipment and, if the Equipment is found by Company not to conform with these warranties (after Buyer has provided Company a reasonable opportunity to perform any appropriate tests on the allegedly defective Equipment), Company will, at its sole option and expense, either repair or replace the Equipment. In all instances, Company reserves the right to require Buyer to deliver the Equipment for repair or replacement to a designated service center and require Buyer to pay all charges for inbound and outbound transportation and for services of any kind, diagnostic or otherwise, excepting only the direct and actual cost of Equipment repair or replacement. Warranty coverage is limited to parts and labor and does not include travel and other expenses. Buyer applications and use of the Equipment may require installation of safety features. Buyer is responsible for furnishing and installing guards or other safety equipment needed to protect operating personnel, even though such

Table 5.45 - Product Warranty

Product	Warranty Period (After Shipment)	Components Excluded
Cyclo® Speed Reducers and Gearmotors	2 Years	Normally Wearing Items
Cyclo® Bevel Buddybox Speed Reducers and Gearmotors	2 Years	Normally Wearing Items
Cyclo® Helical Buddybox Speed Reducers and Gearmotors	2 Years	Normally Wearing Items
Fine Cyclo® Speed Reducers	2 Years	Normally Wearing Items
Beier® Variator Mechanical Adjustable Speed Reducers	2 Years	Normally Wearing Items
Hyponic® Speed Reducers and Gearmotors	2 Years	Normally Wearing Items
Hedcon® Double Enveloping Worm Gear Speed Reducers	2 Years	Normally Wearing Items
Helical Shaft Mount Speed Reducers	2 Years	Normally Wearing Items
Rhytax®	2 Years	Normally Wearing Items
IB Series Servo Gearheads	1 Year	Normally Wearing Items
Astero Gearmotors	1 Year	Normally Wearing Items
Variable Frequency Inverters	1 Year	---
Paramax® Speed Reducers	2 Years	Normally Wearing Items
Compower Planetary Speed Reducers	1 Year	Normally Wearing Items
Hansen UniMiner	2 Years	Normally Wearing Items
Hansen P4	2 Years	Normally Wearing Items
Parts	1 Year	---
Repairs	1 Year	Normally Wearing Items

Cyclo® HBB
 Technical Information