



COMPOWER[®]

Planetary Gear Drive
DP1000 Series

DISTRIBUTED BY



CHAIN & DRIVES[®]
COMPLETE BEARINGS
& POWER TRANSMISSION

SERVICE & SUPPORT

Wangara, WA	Welshpool, WA	Arndell Park, NSW
+61 8 9303 4966	+61 8 6314 1155	+61 2 9674 8611
support@chainanddrives.com.au	salesnsw@chainanddrives.com.au	

chainanddrives.com.au

Specifications, dimensions, and other items are subject to change without prior notice.

CONTENTS

A

Features	A-2
Available Combination	
Reducer and Drive unit	A-4

B

Reducer	
Standard Specifications	B-2
Construction Drawing	B-3
Nomenclature	B-4
Selection	B-6
Service Factor SF	B-8
Selection Tables	B-10
Allowable Radial Load on Low Speed Shaft	B-28
Allowable Radial Load on High Speed Shaft	B-29
Dimension Tables	B-30

C

Technical Data	
Lubrication and Installation	C-2
Painting Specifications and Rust Proof Standard	C-3
Moment of Inertia	C-4
Specifications/Dimensions for Spline shaft	C-6
Dimensions of Motor Adapter JEM / IEC	C-7
Warranty Policy	C-8
Safety Precautions	C-9
Inquiry / Order Specification Sheet form	C-10

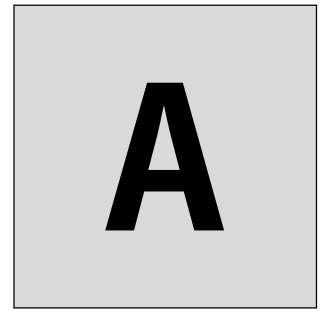

Features

Features	A-2
Available Combination	
Reducer and Drive Unit	A-4

2 Drive Unit

Prepared full lineup of direct motor mount type drive units.
 Simple layout of models can be made due to the unified combination of reducer and basic motor.
 Eliminate the necessity for foundation working for installation and alignment operation.

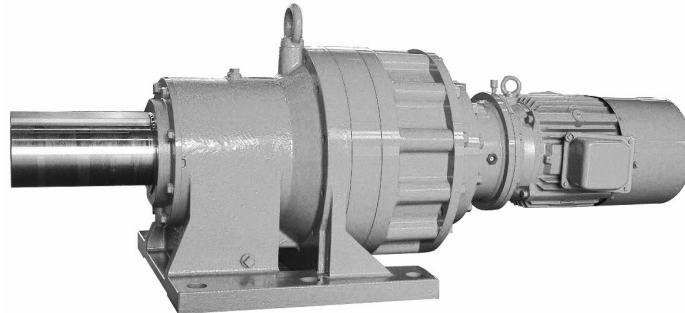

Standard 3-Phase induction motors / 3-Phase induction motors with brake (Indoor type / Outdoor type)

Motor-type	3-Phase Motor		Premium Efficiency 3-Phase Motor		AF motor for inverter drive		Premium Efficiency 3-Phase Motor for inverter drive		High efficiency 3-Phase Motor		
	4P		4P		4P		4P		4P		
	-	With brake	-	With brake	-	With brake	-	With brake	-	With brake	
kW	0.2	●	●			●	●			●	●
	0.25	●	●								
	0.4	●	●			●	●			●	●
	0.55	●	●	●	●						
	0.75			●	●			●	●		
	1.1			●	●						
	1.5			●	●			●	●		
	2.2			●	●			●	●		
	3.0			●	●						
	3.7			●	●			●	●		
	5.5			●	●			●	●		
	7.5			●	●			●	●		
	11			●	●			●	●		
	15			●	●			●	●		
	18.5			●	●			●	●		
	22			●	●			●	●		
	30			●	●	●	●				
37			●	●	●	●					
45			●	●	●	●					
55			●	●							
Specifications	Time rating : S1 (Continuous rating) Applicable voltage : [Standard] 200V 50/60Hz 220V 60Hz or 400V 50/60Hz 440V 60Hz [For inverter drive] 200V 60Hz 220V 60Hz or 400V 60Hz 440V 60Hz About motor with brake : ESB-brake is for 200V-class. In the case power source is 400V-class, use power-transformer for 400V/200V.										

1. Motors with other voltage than as listed are manufactured. Consult us.
2. Consult us about embironmental options, for example outdoor type(IP55), special voltage, dust-proof, explosion-proof, corrosion -proof, water-proof, overseas standard and so on.

3 High strength and rigidity of Planetary Gear system.

- ①Equal distribution of Planetary Gear system.
 Optimum distribution of load to each gear is secured by Planetary Gear system and structure.
 Slimmer diameter can produce bigger transmission power of torque.
- ②High pressure angle gear.
 27-degree pressure angle provides higher tooth strength, which is good for shock loads.



Available Combination

Reducer

Ratio	5	9	16	18	20	22.4	25	28	31.5	35.5	40	45	50	56	63	71	80	90	100	112	125
1010	●	●	●			●			●		●		●			●		●			●
1020	●	●	●			●			●		●		●			●		●			●
1030	●	●	●			●			●		●		●			●		●			●
1040	●	●	●	○	○	●			●	○	●		●			●		●			●
1050	●	●	●	○	○	●			●	○	●		●	○	○	●	○	●	○	○	●
1060	●	●	●	○	○	●	○	○	●	○	●		●	○	○	●	○	●	○	○	●
1070	●	●	●	○	○	●	○	○	●	○	●	○	●	○	○	●	○	●	○	○	●
1080			●	○	○	●	○	○	●	○	●	○	●	○	○	●	○	●	○	○	●
1090			●	○	○	●	○	○	●	○	○	○	●	○	○	●	○	●	○	○	●
1100			○	○	●	●	●	●	●	●	●	●				●	○	○	●	○	○
1110			○	○	●	●	●	●	●	●	●	●				●	○	○	●	○	○
1120			○	○	●	●	●	●	●	●	●	●				●	○	○	●	○	○
1130			○	○	●	●	●	●	●	●	●	●				●	○	○	●	○	○
1140			○	○	●	●	●	●	●	●	●	●				○	○	●	●	●	●
1150																●	●	●	●	●	●
1160																●	●	●	●	●	●
1170																	●	●	●	●	●
1180																	●	●	●	●	●
1185																		●	●	●	●
1190																	●	●	●	●	●
1195																	●	●	●	●	●
1200																		●	●	●	●
1205																			●	●	●
1210																		●	●	●	●
1215																		●	●	●	●
1220																	●	●	●	●	●

● : Standard Models ○ : Manufactured Models (Option)

Remark: This table is applicable only to shaft inline type in the catalogue.

Drive Unit

Ratio	5	9	16	18	20	22.4	25	28	31.5	35.5	40	45	50	56	63	71	80	90	100	112	125	
O/P speed	60Hz	360	200	113	100	90	80	72	64	57	51	45	40	36	32	29	25	23	20	18	16	14
r/min	50Hz	300	167	94	83	75	67	60	54	48	42	38	33	30	27	24	21	19	17	15	13	12
0.2×4																	●		●			●
0.4×4																	●		●			●
0.75×4									●		●		●				●		●			●
1.5×4		●	●			●			●		●		●				●		●			●
2.2×4	●	●	●			●			●		●		●				●		●			●
3.7×4	●	●	●			●			●		●		●				●		●			●
5.5×4	●	●	●			●			●		●		●				●		●			●
7.5×4	●	●	●			●			●		●		●				●		●			●
11×4	●	●	●			●			●		●		●				●		●			●
15×4	●	●	●			●			●		●		●				●		●			●
18.5×4																	●			●		
22×4	●	●	●			●			●		●		●				●		●	●		●
30×4	●	●	●			●			●		●		●				●		●			●
37×4	●	●	●			●			●	●	●	●	●				●		●			●
45×4			●			●			●	●	●	●	●						●			●
55×4			●			●			●	●	●	●	●						●			●

Remark: This table is applicable only for shaft inline type in the catalogue.



140	160	180	200	224	250	280	315	355	400	450	500	560	630	710	800	900	1000	1120	1250	1400	Ratio	
		●		●			●		●			●			●			●		●		1010
		●		●			●		●			●			●			●		●		1020
		●		●			●		●			●			●			●		●		1030
		●		●			●		●			●			●			●		●		1040
○	○	●	○	●			●		●			●			●			●		●		1050
○	○	●	○	●			●		●			●			●			●		●		1060
○	○	●	○	●			●		●			●			●			●		●		1070
○	○	●	○	●			●	○	●	○	○	●	○	○	●	○	○	●	○	○	●	1080
○	○	●	○	●			●	○	●	○	○	●	○	○	●	○	○	●	○	○	●	1090
●	○	●			●	○	●	○	○	●	○	○	●	○	●	●	○	●				1100
●	○	●	○		●	○	●	○	○	●	○	○	●	○	●	●	○	●				1110
●	○	●	○		●	○	●	○	○	●	○	○	●	○	●	●	○	●				1120
●	○	○	○		●	○	●	○	○	●	○	○	●	○	○	●	○	●				1130
●	●	●	●						●	○	○	●	○	○	●	○	●					1140
●	●	●	●					●	●	●	●	●	●	●	●	●	●	●				1150
●	●	●	●					●	●	●	●	●	●	●	●	●	●	●				1160
●	●	●	●					●	●	●	●	●	●	●	●	●	●	●				1170
●	●	●	●	●					●	●	●	●	●	●	●	●	●	●	●			1180
●	●	●	●							●	●	●	●	●	●	●	●	●	●			1185
●	●	●	●	●						●	●	●	●	●	●	●	●	●	●			1190
●	●	●	●							●	●	●	●	●	●	●	●	●	●			1195
●	●	●	●					●	●	●	●	●	●	●	●	●	●	●	●			1200
●	●	●	●						●	●	●	●	●	●	●	●	●	●	●			1205
●	●	●	●	●						●	●	●	●	●	●	●	●	●	●			1210
●	●	●	●	●						●	●	●	●	●	●	●	●	●	●			1215
●	●	●	●	●						●	●	●	●	●	●	●	●	●	●			1220

Size

140	160	180	200	224	250	280	315	355	400	450	500	560	630	710	800	900	1000	1120	1250	1400	Ratio	
		●		●			●		●			●			●			●		●		60Hz
		●		●			●		●			●			●			●		●		O/P speed
		●		●			●		●			●			●			●		●		r/min
		●		●			●		●			●			●	●		●		●		0.2×4
		●		●			●		●			●			●			●		●		0.4×4
		●		●			●		●			●			●			●		●		0.75×4
		●		●			●		●			●	●		●	●		●		●		1.5×4
		●		●			●		●	●		●	●		●	●		●		●		2.2×4
		●		●	●		●		●	●		●	●		●	●		●		●		3.7×4
		●		●	●	●	●		●	●		●	●		●	●		●		●		5.5×4
		●		●	●	●	●		●	●		●	●		●	●		●		●		7.5×4
		●		●	●	●	●		●	●		●	●		●	●		●		●		11×4
●		●							●	●		●	●		●	●						15×4
●							●		●	●		●	●		●	●						18.5×4
●		●			●		●		●	●		●	●		●	●						22×4
									●													30×4
																						37×4
																						45×4
																						55×4

Motor
(kW×P)

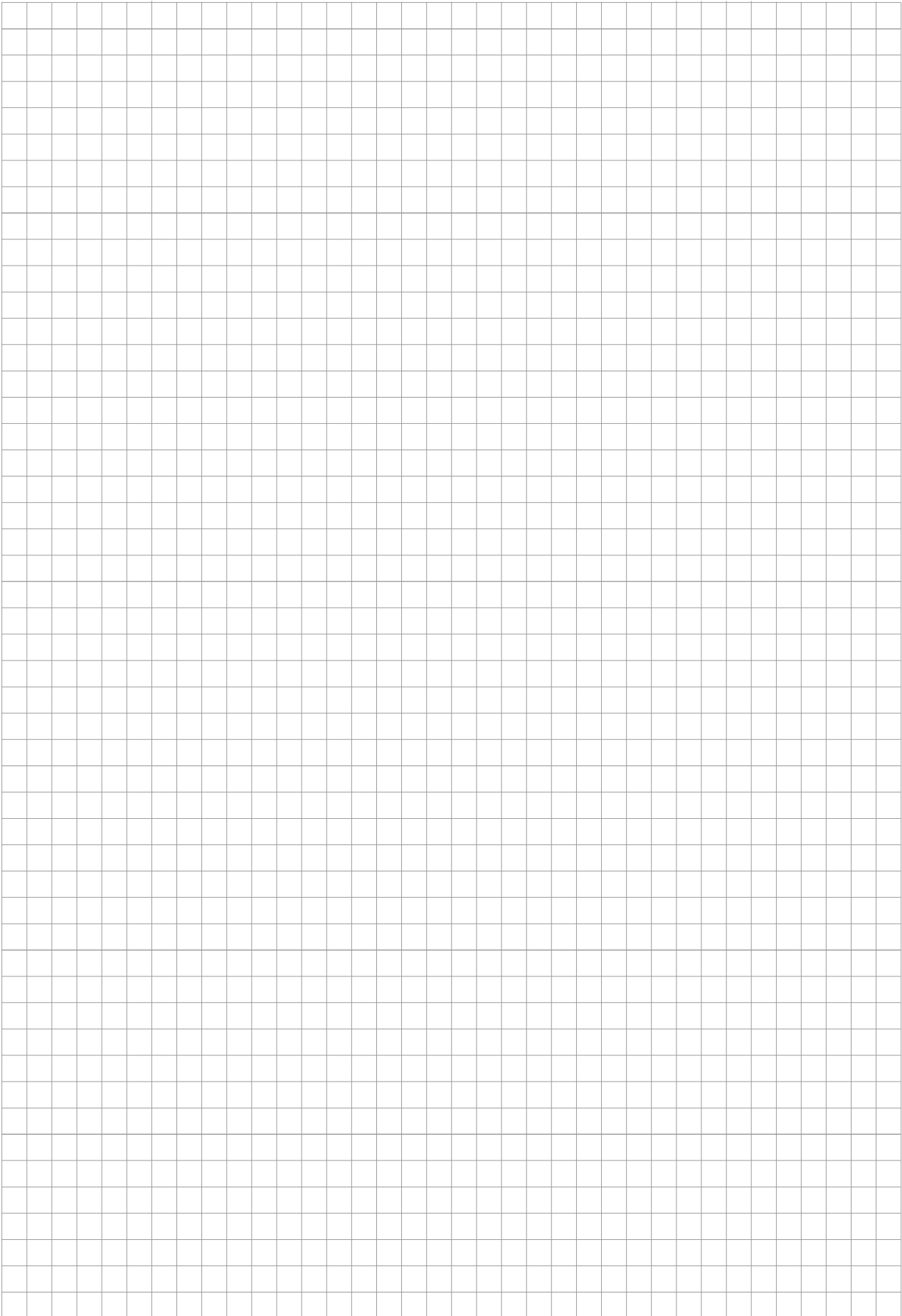

B

Reducer

Reducer

Standard Specifications	B-2
Construction Drawing	B-3
Nomenclature	B-4
Selection	B-6
Service Factor SF	B-8
Selection Tables	B-10
Allowable Radial Load on Low Speed Shaft	B-28
Allowable Radial Load on High Speed Shaft	B-29
Dimension Tables	B-30

■ Reducer Standard Specifications

Item		Standard Specification
Reducer	Lubrication Method	Oil bath lubrication (Some of the upper bearing are lubricated with grease)
	Lubricant	Refer to the page C-2
	Reduction Method	Involute Planetary Gear
	Shaft Direction	Rotation direction of high speed shaft is the same as output shaft
Ambient Conditions	Installation Location	Indoor (Minimal dust and humidity)
	Ambient Temperature	-10°C~40°C (Note1)
	Ambient Humidity	Under 85%
	Elevation	Under 1,000 meters
	Atmosphere	Well-ventilated location, free of corrosive gas, explosive gas, vapors and dust.
Installation	Horizontal installation Refer to the page C-2.	
Method of Coupling with driven Machine	Coupling, gears, chain sprocket or belt.	
Painting	Surface preparation: Shot blasting after washing before machining. Inside painting: Power Bind PTC Grey is sprayed once. Outside painting: For prime coating, Power Bind PTC Grey is sprayed once. For final coating, SUPIKA#3000 is sprayed once. Painting color: Donau Blue (equivalent Munsell color: 6.5PB 3.6 / 8.2). Refer to the page C-3.	

Note1: A heating or cooling system is necessary in case the ambient temperature is lower than -10°C or higher than +40°C.



Construction Drawing

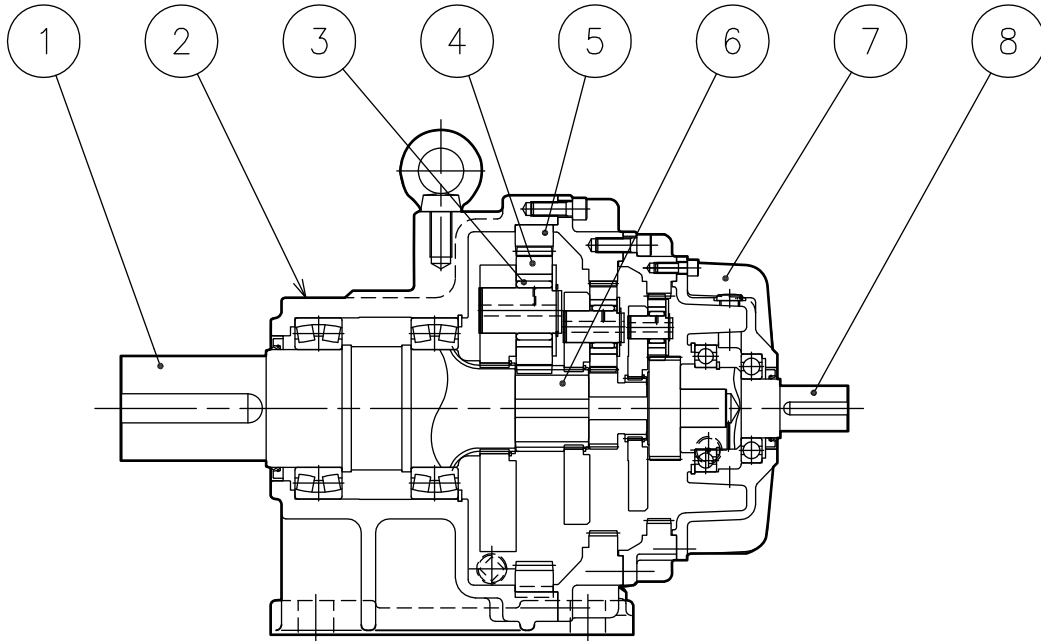

DHG(foot mount type)

No.	Part Name	No.	Part Name
1	Low-Speed Shaft	5	Internal Gear
2	Housing	6	Sun Gear
3	Bearing	7	High-Speed side Cover
4	Planetary Gear	8	High-Speed Shaft

■ Nomenclature

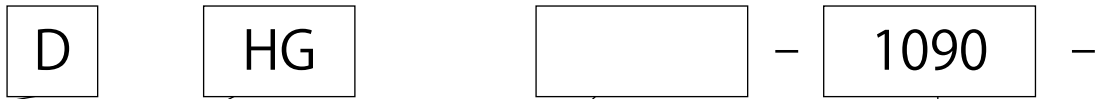

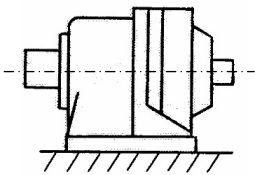
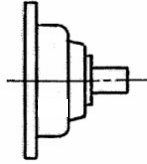
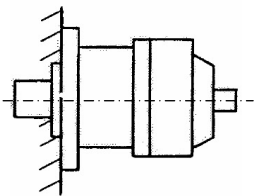
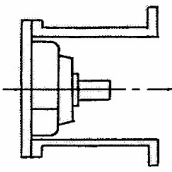
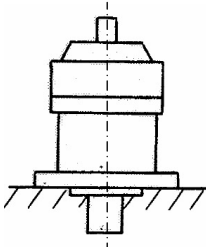
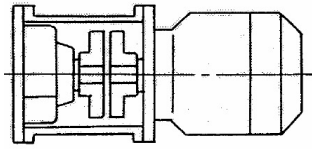
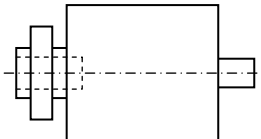
Series	Shaft Direction and Mounting Style	Connection for Motor	Size	
				Torque kNm
D DP 1000 Series Planetary Gear Drive	HG Horizontal 	(Blank) Solid Shaft 	1010	0.46
			1020	0.69
			1030	1.0
			1040	1.6
			1050	3.2
			1060	5.5
			1070	8.6
			1080	13.6
			1090	15.9
			1100	22.6
	HF Horizontal Flange 	J Motor Adaptor 	1110	29.4
			1120	39.2
			1130	53.0
			1140	72.6
			1150	95.2
			1160	128
			1170	157
			1180	186
			1185	225
			1190	275
VF Vertical Flange 	JM Motor Adaptor + Motor 	1195	343	
		1200	402	
		1205	451	
		1210	549	
		1215	647	
		1220	736	
HY Shaft mounting (Option) 				
			Remarks: Above figures of Torque show the transmission power of low speed shaft.	

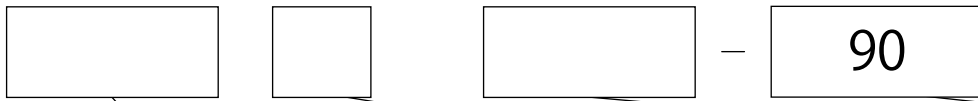

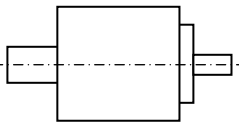
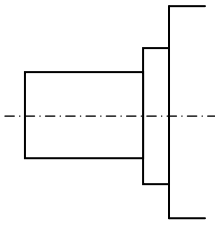
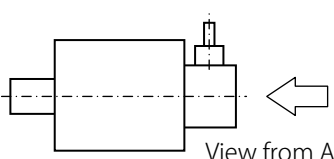
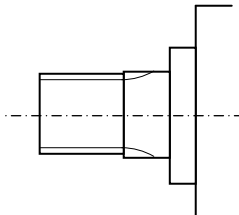
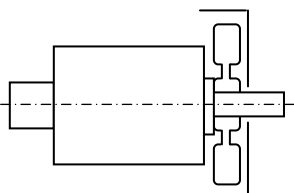
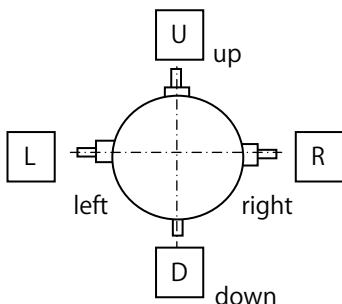
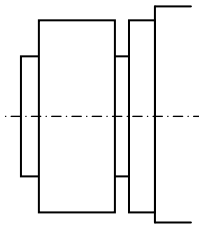
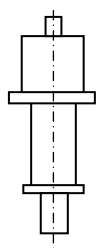
Direction of High Speed Shaft	Low Speed Shaft	Option	Nominal Ratio
<p>(Blank) Inline</p> 	<p>(Blank) Solid Shaft Key type</p> 	<p>(Blank) Standard Specification</p>	<p>5 9 16 18 20 22.4 25 28 31.5 35.5</p>
<p>G※ Right angle (Option)</p> 	<p>P Spline (Option)</p> 	<p>F Cooling Fan (Option)</p> 	<p>40 45 50 56 63 71 80 90 100 112</p>
<p>※Following Direction code will be added. Direction code (View from A)</p>  <p>※"GR" will apply to VF type in spite of Direction code.</p>	<p>T Hollow Shaft Shrink Disk type (Option)</p> 	<p>R Radial Case (Option)</p> 	<p>125 140 160 180 200 224 250 280 315 355 400 450 500 560 630 710 800 900 1000 1120 1250 1400</p>

Reducer Selection

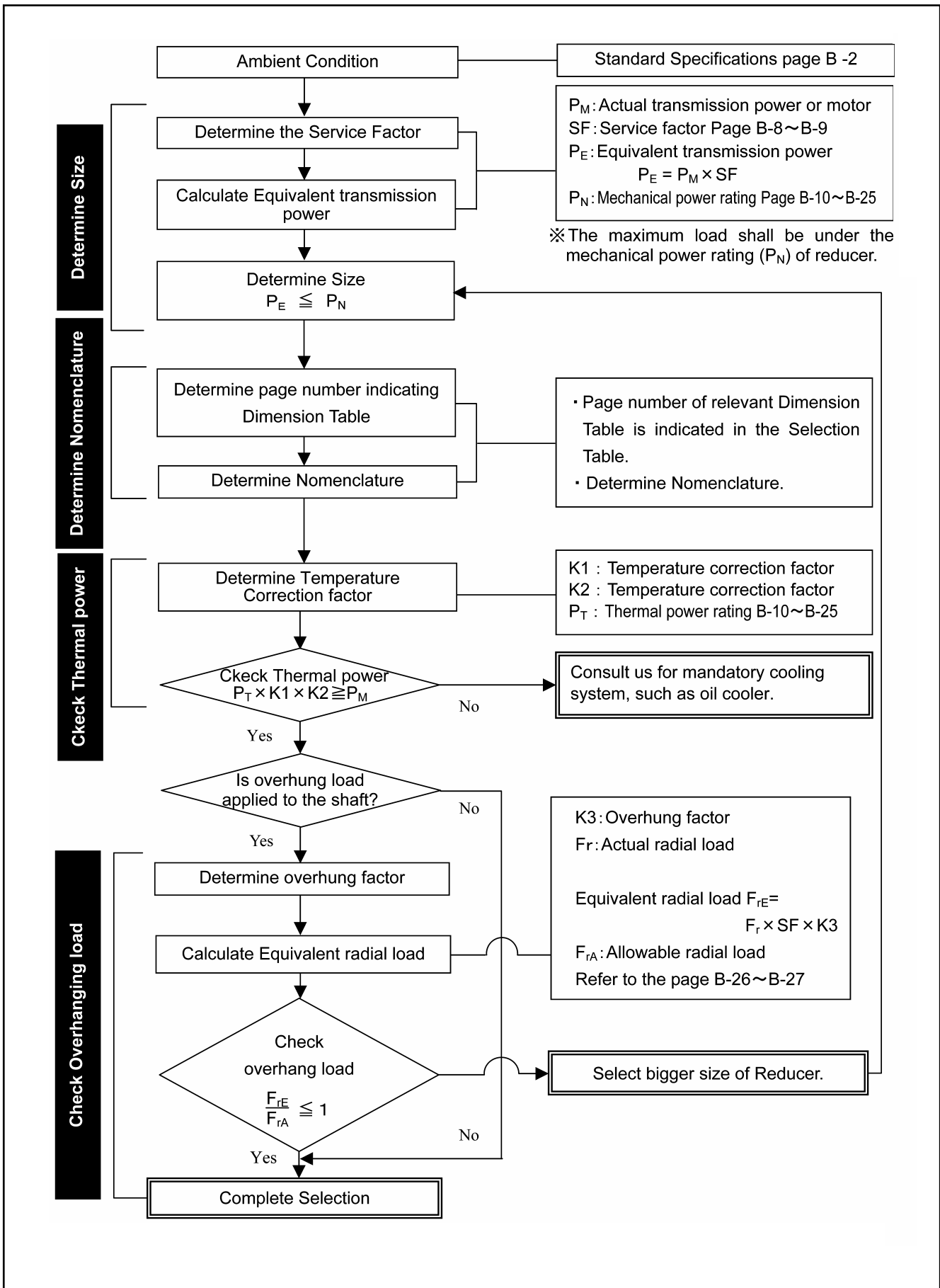



■ Reducer Selection Example

Conditions and final selections	○ : Conditions ■ : Selected item	Reference page No.
○ Ambient Condition	: indoor, Ambient temperature 20°C	B-2 : Standard Specification
■ Check ambient condition	→OK	
○ Motor power	: 22kW (Code : 30)	
○ High speed shaft speed	: 1500r/min	
○ Shaft and mounting positions	: Right Angle Shaft, Horizontal Mounting	
Load condition		
○ Type of load, operating hours, usage	: Uniform load: 14 hours/day, conveyor	B-8 : Service Factor
■ Determine Service Factor	→SF=1.25	
■ Calculate equivalent transmission power	→ $P_E=22 \times 1.25=27.5\text{kW}$	
○ Low speed shaft speed	: 20r/min	B-4~B-5 : Nomenclature
■ Reduction ratio	→ $1500/20=75$	
Select nominal reduction ratio	→75→71	
■ Determine size	→ Size 1080 Nominal reduction ratio 71	B-16 : Selection Tables
■ Determine reducer size, type, reduction ratio	Mechanical power rating $P_N=30.8\text{kW}$ $P_E \leq P_N \rightarrow \text{OK}$	
■ Check dimension		B-32*1 : Dimension Tables
■ Check nomenclature	→DHG-1080-71	Code in Dimension Tables
○ Ambient Temperature	: 20°C	B-9 : Selection Tables
■ Temperature correction factor K1	→K1=1.0	
■ Temperature correction factor K2	→K2=1.0	B-9 : Selection Tables
■ Thermal power rating P_T	→ $P_T=27.2\text{kW}$ → $P_T \times K1 \times K2=27.2 > 22=P_M \rightarrow \text{OK}$	B-14 : Selection Tables
Check overhang load		
○ Overhang member	: Sprocket (Single row)	B-28 : Allowable Radial Load
■ Overhang factor K3	→K3=1.0	
○ Radial load position	: Center of shaft	B-28 : Allowable Radial Load
○ Radial load Fr	: 60kN	
■ Equivalent radial load F_{rE}	→ $F_{rE}=60 \times 1.25 \times 1.0=75\text{kN}$	
■ Allowable radial load	→80.6kN	
$\frac{75}{80.6} = 0.93 < 1$	→OK	
○ Completion of selection		
■ Model selected	→DHG-1080-71	

*1 page number of the relevant Dimension Table is indicated in the Selection Table.

Service Factor SF

Service Factor Table for Driven Machines

Driven Machine						Operating Hours (hours/day)		
						3 hrs	10 hrs	24 hrs
CRANES						The crane classification is based on JIS 「Calculation standard for the structure of crane」		
Classification of crane	Hoisting	Traverse Motion	Travel Motion	Slewing Motion	Boom Hoisting			
Group I	1.00	1.50	1.25	1.00				
Group II	1.25	1.50		1.00				
Group III	1.50	1.75		1.25				
Group IV	1.75	2.00		1.50				
CONVEYORS (General purpose)								
Uniformly load or fed						1.00	1.00	1.25
Heavy load								
Not uniformly fed						1.00	1.25	1.50
Reciprocating or shaker						1.50	1.75	2.00
ELEVATORS								
Elevators						1.50	1.50	1.50
Escalators						1.25	1.25	1.25
METAL MILLS								
Draw bench carriage • main drive						1.50	1.50	1.50
Runout table								
Non reversing								
Group drives						1.50	1.50	1.50
Individual drives						2.00	2.00	2.00
Reversing						2.00	2.00	2.00
Slab pushers						1.50	1.50	1.50
Shears						2.00	2.00	2.00
Wire drawing						1.25	1.25	1.25
Wire winding machine						1.25	1.50	1.50
METAL STRIP PROCESSING MACHINERY								
Bridles						1.50	1.50	1.50
Coilers & uncoilers						1.00	1.25	1.50
Edge trimmers						1.00	1.25	1.50
Flatteners						1.25	1.25	1.50
Loopers						1.50	1.50	2.00
Pinch rolls						1.25	1.25	1.50
Scrap choppers						2.00	2.00	2.00
Shears						2.00	2.00	2.00
Slitters						1.00	1.25	1.50
MILL, ROTARY TYPE								
Ball, Rod						2.00	2.00	2.00
Cement Kilns						2.00	2.00	2.00
Kilns (Except cement kilns)						1.50	1.50	1.50
Dryers, Coolers						1.50	1.50	1.50
SEWAGE DISPOSAL EQUIPMENT								
Aerators						2.00	2.00	2.00
Bar screens						1.25	1.25	1.25
Chemical feeders						1.25	1.25	1.25
Dewatering screens						1.50	1.50	1.50
Scum breakers						1.50	1.50	1.50
mixers						1.50	1.50	1.50
Sludge collectors						1.25	1.25	1.25
Thickeners						1.50	1.50	1.50
Vacuum filters						1.50	1.50	1.50
EXTRUDERS								
Plastics						1.25	1.25	1.25
Rubber						1.50	1.50	1.50
FEEDERS								
Apron						1.00	1.25	1.50
Belt						1.00	1.25	1.50
Disk						1.00	1.00	1.25
Reciprocating						1.50	1.75	2.00
Screw						1.00	1.25	1.50

Driven Machine		Operating Hours (hours/day)		
		3 hrs	10 hrs	24 hrs
RUBBER INDUSTRY				
Mixers		1.75	1.75	2.00
Mixing mill -2smooth rolls		1.50	1.50	1.75
Batch drop mill -2smooth rolls		1.50	1.50	1.50
Cracker warmer				
-2roll : 1 corrugated roll		1.75	1.75	1.75
Cracker 2 corrugated rolls		2.00	2.00	2.00
Holding, feed & blend mill				
-2rolls		1.25	1.25	1.25
Refiner -2 rolls		1.50	1.50	1.50
Calenders		1.50	1.50	1.50
PAPER MILL				
Alltypes incl.Paper making machine		2.00	2.00	2.00
AGITATORS				
Liquids		1.00	1.00	1.25
Liquids and solids		1.00	1.25	1.50
Liquids Variable density		1.00	1.25	1.50
MIXERS				
Concrete		1.25	1.25	1.50
CRUSHER				
Stone		2.50	2.50	2.50
BLOWERS				
Centrifugal		1.00	1.00	1.25
Lobe		1.00	1.25	1.50
Vane		1.00	1.25	1.50
COMPRESSORS				
Centrifugal		1.00	1.00	1.25
Lobe		1.00	1.25	1.50
Reciprocating:multi cylinder		1.50	1.50	1.75
Reciprocating:single cylinder		1.75	1.75	2.00
FANS				
Centrifugal		1.00	1.00	1.25
Cooling towers		※	※	※
Forced draft		1.25	1.25	1.25
Suction draft		1.50	1.50	1.50
Industrial and mine		1.50	1.50	1.50
PUMPS				
Centrifugal		1.00	1.00	1.25
Screw pump		1.25	1.25	1.50
Gear pump		1.25	1.25	1.50
DREDGES				
Cable reels		1.25	1.25	1.50
Conveyors		1.25	1.25	1.50
Cutter head drive		2.00	2.00	2.00
Pumps		2.00	2.00	2.00
Screen drives		1.75	1.75	2.00
Stackers		1.25	1.25	1.50
Winches		1.25	1.25	1.50
GENERATORS				
		1.00	1.00	1.25
HAMMER MILLS				
		1.75	1.75	2.00
SUGAR INDUSTRY				
Beet slicer		2.00	2.00	2.00
Cane knives		1.50	1.50	1.50
Crushers		1.50	1.50	1.50
Mills		1.75	1.75	1.75

Notes

- (1) Values in the above table are based on AGMA standard and our experience.
- (2) Values in the above table apply for electric motors as prime movers if prime mover is a multi cylinder combustion engine, 0.25 has to be added to the SF.
- (3) Consult us for special duty or when special safety specifications are needed.
- (4) ※ : Consult us.



Refer to the following for driven machines not shown on the left page.

Prime Mover	Operating Hours	Type of Load		
		Uniform Load U	Moderate Shock Load M	Heavy Shock Load H
Electric Motor	3 hours/day	1.00	1.00	1.50
	10 hours/day	1.00	1.25	1.75
	24 hours/day	1.25	1.50	2.00
Internal Combustion Engine (multi cylinder)	3 hours/day	1.00	1.25	1.75
	10 hours/day	1.25	1.50	2.00
	24 hours/day	1.50	1.75	2.25

Note: Consult us when the operating hours are less than 3 hours/day or when an internal combustion engine (single cylinder) is used.

Temperature correction factor K1

Load ratio per hour	K1				
	Ambient temperature(°C)				
	Under 10	20	30	40	50
100%	1.15	1.00	0.85	0.70	0.55
80%	1.35	1.20	1.00	0.80	0.65
60%	1.55	1.40	1.15	0.95	0.75
40%	1.75	1.60	1.35	1.10	0.90
20%	1.95	1.80	1.50	1.20	1.00

Note: Use 100% in case the continuous operating hours will be more than two hours.

Temperature correction factor K2

Location	Wind	K2
Indoor/closed	≥0.5m/s	0.7
Indoor/open (Factory in general)	≥1.4m/s	1.0
Outdoor/without direct sunlight	≥3.7m/s	1.4

Overhang factor K3

Overhang Member	K3
Sprocket (single row)	1
Sprocket (double row)	1.25
Gear	1.25
V-belt	1.5
Flat belt	2.5

The starting torque and the stalling torque of premium efficiency 3-phase motors is larger than conventional motors. It is necessary to reexamine service-factor when the motor is driven with the starting-stopping in direct input of commercial power. Consult us.



■ Selection Table Reducer

Reduction ratio	5 · 9
-----------------	-------

Mechanical Power Rating P_N

	H. Speed Shaft Speed n ₁ r/min	L. Speed Shaft Speed n ₂ r/min	Size of Reducer												
			1010	1020	1030	1040	1050	1060	1070	1080	1090	1100	1110		
Nominal Reduction Ratio	1800	360	4.39	7.65	11.7	11.7	23.5	43.0	86.9						
	1500	300	3.67	6.33	9.80	10.1	19.6	35.8	72.4						
	1200	240	2.86	5.10	7.86	8.06	15.7	28.7	58.0						
	1000	200	2.45	4.18	6.53	6.73	13.1	23.9	48.3						
	900	180	2.14	3.78	5.92	6.12	11.7	21.5	43.5						
	750	150	1.84	3.16	4.90	5.10	9.80	18.0	36.2						
9	Exact Reduction Ratio		8.700	8.700	8.700	8.700	8.700	8.700	8.700						
	1800	200	2.65	3.98	7.86	9.29	18.0	36.8	48.2						
	1500	167	2.24	3.88	6.53	7.76	15.3	30.6	45.9						
	1200	133	1.84	3.06	5.20	6.22	12.2	24.5	36.7						
	1000	111	1.53	2.55	4.39	5.10	10.2	20.4	30.6						
	900	100	1.33	2.35	3.88	4.59	9.18	18.4	27.6						
	750	83	1.12	1.94	3.27	3.88	7.65	15.3	23.0						
Dimension Tables	Horizontal		B-30	B-30	B-30	B-30	B-30	B-30	B-30						
	Flange, Horizontal		B-36	B-36	B-36	B-36	B-36	B-36	B-36						
Thermal Power Rating P _T			12.1	12.1	17.6	23.4	34.7	49.6	67.2						

Notes:

1. The high speed shaft speed shall be under 1800 r/min. Consult us when it will be over 1800r/min.
2. When the high speed shaft speed is not shown in the table, find it by the interpolation method.
3. When the high speed shaft speed (n₁) is lower than 750 r/min, find the mechanical power rating (P_N) according to the following formula.

$$P_N = P_{750} \times \frac{N}{750}$$

4. Shown in the table are the ratings for the high speed shaft of reducer.
5. The thermal power ratings (P_T) are applicable to continuous operation at ambient temperatures of 20°C or less.



Unit: kW

Size of Reducer										
1120	1130	1140	1150	1160	1170	1180	1190	1200	1210	1220

■ Selection Table

Reducer

Reduction ratio	16~28
-----------------	-------

Mechanical Power Rating P_N

Nominal Reduction Ratio	H. Speed Shaft Speed _{n1} r/min	L. Speed Shaft Speed _{n2} r/min	Size of Reducer											
			1010	1020	1030	1040	1050	1060	1070	1080	1090	1100	1110	
16	Exact Reduction Ratio		16.17	16.17	16.17	16.17	16.17	16.17	16.17	16.17	16.17	16.17	*16.17	*16.17
	1800	113	3.13	4.75	7.50	9.68	22.5	38.0	65.5	104	130			
	1500	94	2.96	4.49	7.10	9.17	21.3	36.0	62.0	98.0	120			
	1200	75	2.77	4.20	6.64	8.57	18.0	31.8	50.0	75.5	94.3	117	184	
	1000	63	2.62	3.82	6.10	7.19	15.0	26.5	41.7	62.9	78.6	97.3	161	
	900	56	2.42	3.44	5.49	6.47	13.5	23.9	37.5	56.6	70.7	87.5	145	
	750	47	2.02	2.87	4.57	5.40	11.3	19.9	31.3	47.2	59.0	73.0	121	
18	Exact Reduction Ratio						*18.29	*18.29	*18.29	*18.29	*18.29	*18.29	*18.29	*18.29
	1800	100				9.14	21.6	35.2	61.7	96.5	126	155	225	
	1500	83				8.66	20.4	33.3	58.4	91.4	111	129	198	
	1200	67				7.84	18.0	31.1	50.0	74.5	88.8	103	169	
	1000	56				6.53	15.0	26.5	41.7	62.1	74.0	86.0	142	
	900	50				5.88	13.5	23.9	37.5	55.9	66.6	77.4	128	
	750	42				4.90	11.3	19.9	31.3	46.5	55.5	64.5	107	
20	Exact Reduction Ratio						*19.68	*19.68	*19.68	*19.68	*19.68	*19.68	19.68	19.68
	1800	90				8.69	20.4	33.4	58.6	91.7	109	144	213	
	1500	75				8.02	19.3	31.6	55.5	86.8	90.9	120	188	
	1200	60				6.42	15.9	29.6	48.1	71.0	72.7	95.9	158	
	1000	50				5.35	13.2	25.5	40.1	59.2	60.6	79.9	132	
	900	45				4.81	11.9	22.9	36.1	53.3	54.5	71.9	119	
	750	38				4.01	9.93	19.1	30.0	44.4	45.4	59.9	99.9	
22.4	Exact Reduction Ratio		21.40	21.40	21.40	21.40	21.40	21.40	21.40	21.40	21.40	22.98	22.98	
	1800	80	2.57	4.03	6.17	8.68	18.5	31.2	55.5	86.9	110	136	191	
	1500	67	2.43	3.88	5.84	8.22	17.5	31.3	52.6	75.3	90.6	120	168	
	1200	54	2.28	3.11	5.46	6.22	16.4	27.7	44.2	60.2	60.2	102	136	
	1000	45	2.06	2.59	4.66	5.19	13.7	23.4	36.8	50.2	50.2	87.6	114	
	900	40	1.85	2.33	4.20	4.67	12.3	21.1	33.2	45.2	45.2	79.0	103	
	750	33	1.54	1.94	3.50	3.89	10.3	17.6	27.6	37.6	37.6	66.0	85.7	
25	Exact Reduction Ratio								*24.90	*24.90	*24.90	*23.58	24.90	24.90
	1800	72							28.3	49.7	77.8	90.3	129	181
	1500	60							26.8	47.0	70.1	75.3	113	157
	1200	48							22.4	38.0	56.1	60.2	96.8	126
	1000	40							18.7	31.7	46.8	50.2	81.0	105
	900	36							16.8	28.5	42.1	45.2	73.0	94.8
	750	30						14.0	23.7	35.1	37.6	61.0	79.2	
28	Exact Reduction Ratio								*27.28	*27.28	*27.28	*26.43	27.28	27.28
	1800	64							26.6	46.6	73.0	90.3	121	170
	1500	54							25.2	43.9	64.8	75.3	106	143
	1200	43							22.3	35.1	51.8	60.2	88.6	115
	1000	36							18.6	29.3	43.2	50.2	74.0	96.1
	900	32							16.8	26.3	38.9	45.2	66.7	86.6
	750	27						14.0	21.9	32.4	37.6	55.8	72.4	
Dimension Tables	Horizontal Flange, Horizontal		B-31	B-31	B-31	B-31	B-31	B-31	B-31	B-31	B-31	B-31	B-31	B-31
			B-37	B-37	B-37	B-37	B-37	B-37	B-37	B-37	B-37	B-37	B-37	B-37
Thermal Power Rating P _T			6.0	6.0	8.8	11.7	17.3	24.8	33.6	40.9	48.0	48.5	57.6	

Notes:

1. The high speed shaft speed shall be under 1800 r/min. Consult us when it will be over 1800r/min.
2. When the high speed shaft speed is not shown in the table, find it by the interpolation method.
3. When the high speed shaft speed (n₁) is lower than 750 r/min, find the mechanical power rating (P_N) according to the following formula.

$$P_N = P_{750} \times \frac{N}{750}$$

4. Shown in the table are the ratings for the high speed shaft of reducer.
5. The thermal power ratings (P_T) are applicable to continuous operation at ambient temperatures of 20°C or less.



Unit: kW

			Size of Reducer											
1120	1130	1140	1150	1160	1170	1180	1185	1190	1195	1200	1205	1210	1215	1220
*16.17	*16.17	*16.17												
234	317	345												
206	279	304												
191	259	282												
161	224	249												
*18.29	*18.29	*18.29												
285	386	421												
251	340	371												
214	291	317												
189	256	279												
171	238	259												
143	199	228												
20.07	20.07	20.07												
267	339	394												
235	299	347												
201	255	297												
173	225	261												
156	209	243												
130	181	214												
22.98	22.98	22.98												
243	303	359												
214	267	316												
181	228	270												
152	201	238												
137	187	221												
114	159	194												
24.90	24.90	24.90												
229	284	339												
202	250	299												
168	214	255												
140	188	225												
126	175	209												
106	147	184												
27.28	27.28	27.28												
215	263	318												
189	232	280												
153	198	240												
128	174	211												
115	160	196												
96.5	134	172												
B-31	B-31	B-31												
B-37	B-37	B-37												
70.5	84.1	101												

※Those reduction ratios will be available as option. We, however, recommend standard reduction ratio considering extra cost and delivery date.

■ Selection Table Reducer

Reduction ratio	31.5~45
-----------------	---------

Mechanical Power Rating P_N

Nominal Reduction Ratio	H. Speed Shaft Speed ₁ r/min	L. Speed Shaft Speed ₂ r/min	Size of Reducer										
			1010	1020	1030	1040	1050	1060	1070	1080	1090	1100	1110
31.5	Exact Reduction Ratio		30.32	30.32	30.32	30.32	30.32	30.32	30.32	30.32	30.32	30.32	30.32
	1800	57	2.01	3.16	4.83	6.80	14.5	24.5	41.7	65.2	87.0	112	154
	1500	48	1.91	2.99	4.57	6.44	13.7	23.2	39.5	58.3	73.0	98.6	129
	1200	38	1.76	2.37	4.00	6.02	11.8	20.1	31.6	46.6	58.4	79.8	104
	1000	32	1.47	1.97	3.33	5.07	9.80	16.8	26.3	38.9	48.7	66.7	86.6
	900	29	1.32	1.78	3.00	4.56	8.82	15.1	23.7	35.0	43.8	60.2	78.1
750	24	1.10	1.48	2.50	3.80	7.35	12.6	19.7	29.2	36.5	50.3	65.3	
35.5	Exact Reduction Ratio					*34.31	*34.31	*34.31	*34.31	*34.31	*34.31	34.31	34.31
	1800	51				5.89	13.5	22.6	39.7	62.1	78.3	103	137
	1500	42				5.57	12.8	20.9	35.3	52.1	65.3	88.0	114
	1200	34				4.69	10.5	16.7	28.2	41.7	52.2	70.7	91.8
	1000	28				3.91	8.76	13.9	23.5	34.8	43.5	59.1	76.7
	900	25				3.52	7.88	12.5	21.2	31.3	39.2	53.3	69.2
750	21				2.93	6.57	10.4	17.7	26.1	32.6	44.5	57.8	
40	Exact Reduction Ratio		39.79	39.79	39.79	39.79	39.79	39.79	39.79	39.79	*39.79	39.79	39.79
	1800	45	1.66	2.61	3.99	7.03	12.0	18.8	33.6	52.5	52.5	91.0	118
	1500	38	1.58	2.47	3.85	5.73	11.3	15.7	30.4	45.0	49.7	76.1	98.8
	1200	30	1.36	2.02	3.08	4.69	9.06	12.5	24.4	36.0	45.0	61.1	79.3
	1000	25	1.13	1.68	2.57	3.91	7.55	10.4	20.3	30.0	37.5	51.1	66.3
	900	23	1.02	1.51	2.31	3.52	6.80	9.39	18.3	27.0	33.8	46.1	59.8
750	19	0.85	1.26	1.93	2.93	5.66	7.83	15.2	22.5	28.1	38.5	50.0	
45	Exact Reduction Ratio							*47.81	*47.81	*47.81	47.81	47.81	
	1800	40						25.3	45.4	45.4	73.6	87.5	
	1500	33						21.1	37.9	42.0	61.5	73.1	
	1200	27						16.9	30.3	33.6	49.4	58.7	
	1000	22						14.1	25.2	28.0	41.3	49.1	
	900	20						12.7	22.7	25.2	37.2	44.2	
750	17						10.6	18.9	21.0	31.1	37.0		
Dimension Tables	Horizontal Flange, Horizontal		B-31	B-31	B-31	B-31	B-31	B-31	B-31	B-31	B-31	B-31	B-31
			B-37	B-37	B-37	B-37	B-37	B-37	B-37	B-37	B-37	B-37	B-37
Thermal Power Rating P _T			6.0	6.0	8.8	11.7	17.3	24.8	33.6	40.9	48.0	48.5	57.6

Notes:

1. The high speed shaft speed shall be under 1800 r/min. Consult us when it will be over 1800r/min.
2. When the high speed shaft speed is not shown in the table, find it by the interpolation method.
3. When the high speed shaft speed (n₁) is lower than 750 r/min, find the mechanical power rating (P_N) according to the following formula.

$$P_N = P_{750} \times \frac{N}{750}$$

4. Shown in the table are the ratings for the high speed shaft of reducer.
5. The thermal power ratings (P_T) are applicable to continuous operation at ambient temperatures of 20°C or less.



Unit: kW

			Size of Reducer											
1120	1130	1140	1150	1160	1170	1180	1185	1190	1195	1200	1205	1210	1215	1220
30.32	30.32	30.32												
200	241	296												
172	212	260												
138	182	222												
115	160	196												
104	145	182												
87.0	121	159												
34.31	34.31	34.31												
182	219	271												
152	192	239												
122	165	204												
102	142	180												
92.2	128	167												
77.0	107	141												
39.79	39.79	39.79												
157	194	244												
132	171	215												
106	146	184												
88.4	123	162												
79.7	111	146												
66.6	92.5	122												
47.81	47.81	47.81												
131	171	213												
110	151	178												
88.3	123	143												
73.8	102	119												
66.5	92.4	108												
55.6	77.2	90.0												
B-31	B-31	B-31												
B-37	B-37	B-37												
70.5	84.1	101												

※Those reduction ratios will be available as option. We, however, recommend standard reduction ratio considering extra cost and delivery date.

■ Selection Table Reducer

Reduction ratio	50~90
-----------------	-------

Mechanical Power Rating P_N

Nominal Reduction Ratio	H. Speed Shaft Speed _{n₁} r/min	L. Speed Shaft Speed _{n₂} r/min	Size of Reducer											
			1010	1020	1030	1040	1050	1060	1070	1080	1090	1100	1110	
50	Exact Reduction Ratio		51.74	51.74	51.74	51.74	51.74	51.74	51.74	51.74	51.74	51.74		
	1800	36	1.41	2.15	3.39	4.88	9.68	17.2	29.0	42.9	53.7			
	1500	30	1.34	2.01	3.06	4.15	8.60	15.3	24.2	35.7	44.7			
	1200	24	1.08	1.60	2.45	3.25	6.88	12.2	19.4	28.6	35.8			
	1000	20	0.90	1.34	2.04	2.71	5.73	10.2	16.1	23.8	29.8			
	900	18	0.81	1.20	1.84	2.44	5.16	9.18	14.5	21.4	26.8			
	750	15	0.68	1.00	1.53	2.03	4.30	7.65	12.1	17.9	22.4			
56	Exact Reduction Ratio						*58.51	*58.51	*58.51	*58.51	*58.51			
	1800	32					9.22	15.9	25.7	37.9	47.5			
	1500	27					7.81	13.5	21.4	31.6	39.6			
	1200	21					6.25	10.8	17.1	25.3	31.6			
	1000	18					5.21	9.00	14.3	21.1	26.4			
	900	16					4.69	8.10	12.8	19.0	23.7			
	750	13					3.91	6.75	10.7	15.8	19.8			
63	Exact Reduction Ratio						*62.97	*62.97	*62.97	*62.97	*62.97			
	1800	29					8.72	15.1	24.1	35.6	44.6			
	1500	24					7.48	12.8	20.1	29.7	37.2			
	1200	19					5.99	10.2	16.1	23.8	29.7			
	1000	16					4.99	8.53	13.4	19.8	24.8			
	900	14					4.49	7.68	12.1	17.8	22.3			
	750	12					3.74	6.40	10.1	14.8	18.6			
71	Exact Reduction Ratio		68.48	68.48	68.48	68.48	68.48	68.48	68.48	68.48	68.48	81.69	76.99	
	1800	25	1.16	1.82	2.79	4.28	8.26	14.1	22.2	32.8	41.0	45.9	73.5	
	1500	21	1.03	1.53	2.34	3.72	6.88	11.8	18.5	30.8	34.2	39.0	61.2	
	1200	17	0.83	1.23	1.87	2.85	5.50	9.41	14.8	21.8	27.3	31.2	49.0	
	1000	14	0.69	1.02	1.56	2.37	4.59	7.84	12.3	18.2	22.8	26.0	40.8	
	900	13	0.62	0.92	1.40	2.14	4.13	7.06	11.1	16.4	20.5	23.4	36.7	
	750	11	0.52	0.77	1.17	1.78	3.44	5.88	9.24	13.7	17.1	19.5	30.6	
80	Exact Reduction Ratio						*83.34	*83.34	*83.34	*83.34	*83.34	*92.39	*87.07	
	1800	23					6.86	9.53	18.4	27.2	34.1	42.4	67.6	
	1500	19					5.72	7.94	15.4	22.7	28.4	37.7	56.3	
	1200	15					4.58	6.35	12.3	18.2	22.7	31.2	45.1	
	1000	13					3.81	5.30	10.2	15.1	18.9	26.0	37.5	
	900	11					3.43	4.77	9.22	13.6	17.0	23.4	33.8	
	750	9.4					2.86	3.97	7.68	11.3	14.2	19.5	28.2	
90	Exact Reduction Ratio		90.63	90.63	90.63	90.63	90.63	90.63	90.63	90.63	90.63	*99.43	*93.71	
	1800	20	0.95	1.41	2.15	3.27	6.31	9.53	17.0	25.0	31.4	40.3	62.8	
	1500	17	0.79	1.17	1.79	2.72	5.26	7.94	14.1	20.9	26.1	35.9	52.3	
	1200	13	0.63	0.94	1.43	2.18	4.21	6.35	11.3	16.7	20.9	30.0	41.9	
	1000	11	0.53	0.78	1.19	1.81	3.51	5.30	9.42	13.9	17.4	25.0	34.9	
	900	10	0.47	0.70	1.07	1.63	3.16	4.77	8.48	12.5	15.7	22.5	31.4	
	750	8.3	0.39	0.59	0.89	1.36	2.63	3.97	7.07	10.4	13.1	18.7	26.2	
Dimension Tables	Horizontal Flange, Horizontal		B-32	B-32	B-32	B-32	B-32	B-32	B-32	B-32	B-32	B-33	B-33	
			B-38	B-38	B-38	B-38	B-38	B-38	B-38	B-38	B-38	B-38	B-39	B-39
Thermal Power Rating P _T			4.1	4.1	5.9	7.7	11.5	16.5	22.4	27.2	32.0	32.2	36.3	

Notes:

1. The high speed shaft speed shall be under 1800 r/min. Consult us when it will be over 1800r/min.
2. When the high speed shaft speed is not shown in the table, find it by the interpolation method.
3. When the high speed shaft speed (n₁) is lower than 750 r/min, find the mechanical power rating (P_N) according to the following formula.

$$P_N = P_{750} \times \frac{N}{750}$$

4. Shown in the table are the ratings for the high speed shaft of reducer.
5. The thermal power ratings (P_T) are applicable to continuous operation at ambient temperatures of 20°C or less.



Unit: kW

Size of Reducer														
1120	1130	1140	1150	1160	1170	1180	1185	1190	1195	1200	1205	1210	1215	1220
76.99	76.99	*76.99	73.49	73.49										
102	137	171	222	299										
84.9	114	143	195	263										
67.9	91.7	114	167	222										
56.6	76.4	95.0	140	186										
51.0	68.8	85.7	127	167										
42.5	57.3	71.4	106	140										
*87.07	*87.07	*87.07	83.12	83.12	82.88	79.37		79.37	80.38					85.58
90.1	115	152	204	274	300	421		459	594					1586
75.1	101	126	179	241	264	370		404	523					1396
60.1	81.1	101	149	197	226	313		345	447					1147
50.1	67.6	84.2	124	164	199	261		304	394					956
45.1	60.8	75.8	112	148	185	235		282	366					860
37.5	50.7	63.1	93.7	124	158	196		249	322					717
*93.71	*93.71	93.71	89.45	91.25	92.28	89.77	85.10	89.77	91.14	86.28		92.47	88.90	99.41
83.7	107	141	194	257	275	386	421	421	536	798		1147	1223	1428
69.8	89.0	117	170	223	242	340	370	371	472	702		989	1076	1234
55.8	71.2	94.0	138	179	207	277	317	317	404	601		792	921	987
46.5	59.4	78.2	116	150	182	231	279	279	355	518		660	789	823
41.9	53.4	70.4	104	135	170	208	259	259	334	466		594	711	740
34.9	44.5	58.7	87.1	113	142	173	220	228	294	389		495	595	617
B-33	B-33	B-33												
B-39	B-39	B-39	B-39	B-39	B-39	B-39	B-39	B-39	B-39	B-39	B-39	B-39	B-39	B-39
43.5	52.4	64.4	74.8	91.8	103	114	123	145	158	181		221	252	275

*Those reduction ratios will be available as option. We, however, recommend standard reduction ratio considering extra cost and delivery date.

■ Selection Table Reducer

Reduction ratio	100~180
-----------------	---------

Mechanical Power Rating P_N

Nominal Reduction Ratio	H. Speed Shaft Speed _{n₁} r/min	L. Speed Shaft Speed _{n₂} r/min	Size of Reducer											
			1010	1020	1030	1040	1050	1060	1070	1080	1090	1100	1110	
100	Exact Reduction Ratio							*97.01	*97.01	*97.01	*97.01	*97.01	108.1	101.9
	1800	18						4.77	9.53	15.8	23.4	29.3	37.7	57.7
	1500	15						3.97	7.94	13.2	19.5	24.4	33.8	48.1
	1200	12						3.18	6.35	10.6	15.6	19.5	27.6	38.5
	1000	10						2.65	5.30	8.80	13.0	16.3	23.0	32.1
	900	9.0						2.38	4.77	7.92	11.7	14.6	20.7	28.9
	750	7.5					1.99	3.97	6.60	9.75	12.2	17.2	24.1	
112	Exact Reduction Ratio							*109.7	*109.7	*109.7	*109.7	*109.7	*125.8	*118.6
	1800	16						4.77	9.02	14.2	20.9	26.2	32.9	49.6
	1500	13						3.97	7.51	11.8	17.4	21.8	26.7	41.4
	1200	11						3.18	6.01	9.45	13.9	17.5	22.0	33.1
	1000	8.9						2.65	5.01	7.87	11.6	14.6	18.3	27.6
	900	8.0						2.38	4.51	7.08	10.5	13.1	16.5	24.8
	750	6.7					1.99	3.76	5.90	8.72	10.9	13.7	20.7	
125	Exact Reduction Ratio		128.4	128.4	128.4	128.4	128.4	128.4	128.4	128.4	128.4	128.4	*137.9	*129.9
	1800	14	0.68	1.00	1.53	2.33	4.51	7.70	12.1	17.9	22.4	32.0	45.3	
	1500	12	0.56	0.84	1.28	1.94	3.75	6.42	10.1	14.9	18.7	27.3	37.7	
	1200	9.6	0.45	0.67	1.02	1.55	3.00	5.14	8.07	11.9	14.9	21.8	30.2	
	1000	8.0	0.38	0.56	0.85	1.29	2.50	4.28	6.72	9.93	12.4	18.2	25.2	
	900	7.2	0.34	0.50	0.77	1.17	2.25	3.85	6.05	8.94	11.2	16.4	22.6	
	750	6.0	0.28	0.42	0.64	0.97	1.88	3.21	5.04	7.45	9.33	13.6	18.9	
140	Exact Reduction Ratio							*145.3	*145.3	*145.3	*145.3	*145.3	153.2	144.4
	1800	13						3.63	6.88	9.53	16.0	20.0	29.5	40.8
	1500	11						3.02	5.74	7.94	13.3	16.7	24.5	34.0
	1200	8.6						2.42	4.59	6.35	10.6	13.3	19.6	27.2
	1000	7.1						2.02	3.82	5.30	8.87	11.1	16.4	22.6
	900	6.4						1.81	3.44	4.77	7.99	10.0	14.7	20.4
	750	5.4					1.51	2.87	3.97	6.66	8.33	12.3	17.0	
160	Exact Reduction Ratio							*168.5	*168.5	*168.5	*168.5	*168.5	*173.3	*163.4
	1800	11						3.47	5.94	9.33	13.8	17.2	24.6	36.0
	1500	9.4						2.89	4.95	7.77	11.5	14.4	20.5	30.0
	1200	7.5						2.31	3.96	6.22	9.18	11.5	16.4	24.0
	1000	6.3						1.93	3.30	5.18	7.65	9.58	13.6	20.0
	900	5.6						1.74	2.97	4.66	6.89	8.62	12.3	18.0
	750	4.7					1.45	2.47	3.89	5.74	7.19	10.2	15.0	
180	Exact Reduction Ratio		181.9	181.9	181.9	181.9	181.9	181.9	181.9	181.9	181.9	181.9	201.0	189.5
	1800	10	0.48	0.72	1.09	1.66	3.22	5.50	8.64	12.8	16.0	20.0	28.4	31.1
	1500	8.3	0.40	0.60	0.91	1.39	2.68	4.58	7.20	10.6	13.3	15.3	21.3	25.9
	1200	6.7	0.32	0.48	0.73	1.11	2.14	3.67	5.76	8.51	10.7	12.3	17.3	20.7
	1000	5.6	0.27	0.40	0.61	0.92	1.79	3.06	4.80	7.09	8.88	10.2	14.3	17.3
	900	5.0	0.24	0.36	0.55	0.83	1.61	2.75	4.32	6.38	7.99	9.20	12.5	15.5
	750	4.2	0.20	0.30	0.46	0.69	1.34	2.29	3.60	5.32	6.66	7.67	12.9	
Dimension Tables	Horizontal Flange, Horizontal	B-32	B-32	B-32	B-32	B-32	B-32	B-32	B-32	B-32	B-32	B-32	B-33	B-33
		B-38	B-38	B-38	B-38	B-38	B-38	B-38	B-38	B-38	B-38	B-38	B-39	B-39
Thermal Power Rating P _T		4.1	4.1	5.9	7.7	11.5	16.5	22.4	27.2	32.0	32.2	36.3		

- Notes:
1. The high speed shaft speed shall be under 1800 r/min. Consult us when it will be over 1800r/min.
 2. When the high speed shaft speed is not shown in the table, find it by the interpolation method.
 3. When the high speed shaft speed (n₁) is lower than 750 r/min, find the mechanical power rating (P_N) according to the following formula.

$$P_N = P_{750} \times \frac{N}{750}$$
 4. Shown in the table are the ratings for the high speed shaft of reducer.
 5. The thermal power ratings (P_T) are applicable to continuous operation at ambient temperatures of 20°C or less.



Unit: kW

Size of Reducer														
1120	1130	1140	1150	1160	1170	1180	1185	1190	1195	1200	1205	1210	1215	1220
101.9	101.9	109.4	104.5	104.5	105.2	98.54	96.24	98.54	98.21	96.12	97.40	103.6	99.14	105.5
77.0	88.5	133	174	234	291	339	386	394	504	740	770	1058	1133	1370
64.2	73.7	111	148	196	249	299	340	347	443	651	677	884	997	1162
51.3	59.0	88.5	119	157	199	252	291	297	379	557	579	707	848	930
42.8	49.2	73.7	99.3	131	166	210	256	261	334	465	510	590	709	775
38.5	44.2	66.4	89.5	118	149	189	229	243	310	419	462	531	639	697
32.1	36.9	55.3	74.8	98.8	124	158	195	214	273	349	386	442	534	581
*118.6	*112.3	118.6	113.2	113.2	113.7	112.8	105.7	112.8	112.1	109.5	109.6	110.6	111.0	121.3
66.2	93.4	122	164	216	273	303	339	359	518	675	708	992	1047	1214
55.1	77.9	102	137	181	230	267	299	316	456	594	623	828	921	1011
44.1	62.3	81.6	110	145	184	220	255	270	390	490	533	663	759	809
36.8	51.9	68.0	91.7	121	153	184	225	238	340	408	456	552	634	674
33.1	46.7	61.2	82.7	109	138	165	209	221	306	367	411	497	572	607
27.6	38.9	51.0	69.1	91.3	115	138	178	194	255	306	343	414	478	506
*129.9	*125.9	129.9	124.0	124.0	124.1	122.2	121.0	122.2	121.3	118.3	126.8	118.9	127.5	131.7
60.4	84.2	112	150	198	253	284	303	339	490	640	640	924	950	1118
50.3	70.1	93.1	125	165	211	250	267	299	432	563	563	770	824	931
40.3	56.1	74.5	100	133	169	203	228	255	369	454	473	616	662	745
33.5	46.8	62.1	83.8	111	141	169	201	225	315	378	395	513	553	621
30.2	42.1	55.9	75.5	99.9	127	153	186	209	283	340	356	462	499	559
25.2	35.1	46.6	63.1	83.4	105	127	155	184	236	283	297	385	417	466
144.4	144.4	144.4	137.8	137.8	137.2	133.9	143.6	133.9	146.7	142.3	138.2	141.7	138.4	144.6
54.4	73.4	101	135	178	229	263	263	318	429	562	602	776	897	1018
45.3	61.1	83.8	113	149	191	232	232	280	378	471	530	646	761	848
36.2	48.9	67.1	90.4	120	153	186	198	240	312	377	434	517	611	679
30.2	40.8	55.9	75.5	99.9	127	155	174	211	260	314	363	431	510	566
27.2	36.7	50.3	68.1	90.0	114	139	157	196	234	283	327	388	460	509
22.6	30.6	41.9	56.9	75.2	95.4	116	131	171	195	236	272	323	384	424
*163.4	*163.4	163.4	155.9	155.9	154.3	148.8	159.6	148.8	165.1	159.4	152.5	157.7	151.9	161.0
48.0	64.8	88.9	119	158	204	241	241	296	395	505	562	697	830	914
40.0	54.0	74.1	99.8	132	170	209	212	260	347	421	491	581	694	762
32.0	43.2	59.3	80.1	106	136	167	182	222	277	337	394	464	557	609
26.7	36.0	49.4	66.9	88.4	113	139	157	196	231	280	329	387	466	508
24.0	32.4	44.5	60.3	79.7	102	125	141	182	208	252	296	348	420	457
20.0	27.0	37.0	50.3	66.5	84.8	104	118	154	173	210	247	290	351	381
189.5	*189.5	189.5	180.9	180.9	177.4	168.4	180.6	168.4	190.0	182.2	170.9	178.8	169.1	182.6
41.4	55.9	76.6	103	136	177	219	219	271	358	442	519	615	747	806
34.5	46.6	63.9	86.2	114	148	185	192	239	301	368	439	512	625	672
27.6	37.3	51.1	69.2	91.4	118	148	165	204	241	294	352	410	501	537
23.0	31.1	42.6	57.8	76.3	98.3	123	139	180	201	245	293	341	419	448
20.7	28.0	38.3	52.0	68.8	88.5	111	125	163	181	221	264	307	378	403
17.3	23.3	31.9	43.5	57.5	73.8	92.3	104	136	151	184	220	256	316	336
B-33	B-33	B-33												
B-39	B-39	B-39	B-39	B-39	B-39	B-39	B-39	B-39	B-39	B-39	B-39	B-39	B-39	B-39
43.5	52.4	64.4	74.8	91.8	103	114	123	145	158	181	187	221	252	275

*Those reduction ratios will be available as option. We, however, recommend standard reduction ratio considering extra cost and delivery date.

■ Selection Table Reducer

Reduction ratio	200~224
-----------------	---------

Mechanical Power Rating P_N

Nominal Reduction Ratio	H. Speed Shaft Speed n_1 , r/min	L. Speed Shaft Speed n_2 , r/min	Size of Reducer											
			1010	1020	1030	1040	1050	1060	1070	1080	1090	1100	1110	
200	Exact Reduction Ratio							*205.8	*205.8	*205.8	*205.8	*205.8		*227.7
	1800	9.0						2.87	4.91	7.18	11.4	14.1		24.8
	1500	7.5						2.39	4.10	5.98	9.50	11.8		20.7
	1200	6.0						1.92	3.28	4.79	7.60	9.43		16.6
	1000	5.0						1.60	2.73	3.99	6.34	7.86		13.8
	900	4.5						1.44	2.46	3.59	5.70	7.07		12.4
	750	3.8					1.20	2.05	2.99	4.75	5.90		10.3	
224	Exact Reduction Ratio		238.7	238.7	238.7	238.7	238.7	238.7	238.7	238.7	238.7	238.7		
	1800	8.0	0.37	0.55	0.84	1.28	2.48	4.24	6.66	9.83	12.3			
	1500	6.7	0.31	0.46	0.70	1.07	2.06	3.53	5.85	8.19	10.3			
	1200	5.4	0.25	0.37	0.56	0.85	1.65	2.82	4.44	6.55	8.21			
	1000	4.5	0.21	0.31	0.47	0.71	1.38	2.35	3.70	5.46	6.84			
	900	4.0	0.19	0.28	0.42	0.64	1.24	2.12	3.33	4.92	6.16			
	750	3.3	0.15	0.23	0.35	0.53	1.03	1.77	2.77	4.10	5.13			
Dimension Tables	Horizontal Flange, Horizontal		B-32	B-32	B-32	B-32	B-32	B-32	B-32	B-32	B-32	B-32		B-33
			B-38	B-38	B-38	B-38	B-38	B-38	B-38	B-38	B-38	B-38		B-39
Thermal Power Rating P_T			4.1	4.1	5.9	7.7	11.5	16.5	22.4	27.2	32.0			36.3

Notes:

1. The high speed shaft speed shall be under 1800 r/min. Consult us when it will be over 1800r/min.
2. When the high speed shaft speed is not shown in the table, find it by the interpolation method.
3. When the high speed shaft speed (n_1) is lower than 750 r/min, find the mechanical power rating (P_N) according to the following formula.

$$P_N = P_{750} \times \frac{N}{750}$$

4. Shown in the table are the ratings for the high speed shaft of reducer.
5. The thermal power ratings (P_T) are applicable to continuous operation at ambient temperatures of 20°C or less.



Unit: kW

Size of Reducer														
1120	1130	1140	1150	1160	1170	1180	1185	1190	1195	1200	1205	1210	1215	1220
*227.7	*227.7	227.7	217.3	217.3	210.4	195.3	209.4	195.3		214.2	195.4	207.9	191.7	212.4
34.5	40.6	63.8	86.1	114	149	191	194	244		376	460	529	660	693
28.7	33.8	53.2	71.9	95.0	124	159	171	215		313	385	441	552	578
23.0	27.0	42.5	57.7	76.3	99.5	127	144	184		250	308	352	443	462
19.1	22.5	35.4	48.2	63.7	82.9	106	120	156		209	257	294	370	385
17.2	20.2	31.9	43.4	57.4	74.6	95.4	108	141		188	231	264	334	347
14.4	16.8	26.6	36.2	47.9	62.2	79.5	89.8	117		157	193	220	279	289
						234.7		234.7				250.3	222.8	255.8
						159		215				439	570	575
						132		185				366	476	479
						106		148				293	382	384
						88.3		124				244	319	320
						79.4		111				220	288	288
						66.2		92.7				183	240	240
B-33	B-33													
B-39	B-39	B-39	B-39	B-39	B-39	B-39	B-39	B-39		B-39	B-39	B-39	B-39	B-39
43.5	52.4	64.4	74.8	91.8	103	114	123	145		181	187	221	252	275

※Those reduction ratios will be available as option. We, however, recommend standard reduction ratio considering extra cost and delivery date.

■ Selection Table Reducer

Reduction ratio	250~450
-----------------	---------

Mechanical Power Rating P_N

Nominal Reduction Ratio	H. Speed Shaft Speed _{n₁} r/min	L. Speed Shaft Speed _{n₂} r/min	Size of Reducer												
			1010	1020	1030	1040	1050	1060	1070	1080	1090	1100	1110		
250	Exact Reduction Ratio											261.4	246.4		
	1800	7.2										15.1	24.4		
	1500	6.0										13.0	20.3		
	1200	4.8										10.8	16.3		
	1000	4.0										9.3	13.6		
	900	3.6										8.5	12.2		
280	750	3.0										7.3	10.2		
	Exact Reduction Ratio											*295.7	*278.6		
	1800	6.4										13.7	21.6		
	1500	5.4										11.8	18.0		
	1200	4.3										9.8	14.4		
	1000	3.6										8.4	12.0		
315	900	3.2										7.7	10.8		
	750	2.7										6.4	9.0		
	Exact Reduction Ratio		310.4	310.4	310.4	310.4	310.4	310.4	310.4	310.4	310.4	346.0	326.1		
	1800	5.7	0.30	0.44	0.67	1.02	1.97	3.37	5.27	7.81	9.68	12.0	18.4		
	1500	4.8	0.25	0.37	0.56	0.85	1.64	2.80	4.41	6.51	8.15	10.3	15.4		
	1200	3.8	0.20	0.29	0.45	0.68	1.31	2.24	3.53	5.21	6.52	8.6	12.3		
355	1000	3.2	0.16	0.24	0.37	0.57	1.09	1.87	2.94	4.34	5.43	7.3	10.2		
	900	2.9	0.15	0.22	0.33	0.51	0.98	1.68	2.64	3.91	4.89	6.6	9.2		
	750	2.4	0.12	0.18	0.28	0.42	0.82	1.40	2.20	3.25	4.07	5.5	7.7		
	Exact Reduction Ratio										*351.1	*351.1	*391.3	*368.8	
	1800	5.1									6.98	8.74	9.3	16.3	
	1500	4.2									5.82	7.28	7.8	13.6	
400	1200	3.4									4.65	5.83	6.2	10.9	
	1000	2.8									3.88	4.86	5.2	9.1	
	900	2.5									3.49	4.37	4.7	8.2	
	750	2.1									2.91	3.64	3.9	6.8	
	Exact Reduction Ratio		410.9	410.9	410.9	410.9	410.9	410.9	410.9	410.9	410.9	410.9	*421.1	*396.9	
	1800	4.5	0.22	0.33	0.51	0.77	1.49	2.56	4.02	5.93	7.43	9.3	15.2		
450	1500	3.8	0.19	0.28	0.42	0.64	1.25	2.13	3.35	4.94	6.19	7.8	12.6		
	1200	3.0	0.15	0.22	0.34	0.52	1.00	1.70	2.68	3.95	4.95	6.2	10.1		
	1000	2.5	0.12	0.19	0.28	0.43	0.83	1.42	2.23	3.30	4.13	5.2	8.4		
	900	2.3	0.11	0.17	0.25	0.39	0.75	1.28	2.01	2.97	3.71	4.7	7.6		
	750	1.9	0.09	0.14	0.21	0.32	0.62	1.07	1.67	2.47	3.09	3.9	6.3		
	Exact Reduction Ratio										*464.7	*464.7	457.9	462.0	
450	1800	4.0										4.87	6.67	9.3	13.0
	1500	3.3										4.06	5.56	7.8	10.8
	1200	2.7										3.25	4.45	6.2	8.7
	1000	2.2										2.71	3.71	5.2	7.2
	900	2.0										2.43	3.34	4.7	6.5
	750	1.7										2.03	2.78	3.9	5.4
Dimension Tables	Horizontal Flange, Horizontal	B-34	B-34	B-34	B-34	B-34	B-34	B-34	B-34	B-34	B-34	B-35	B-35		
		B-40	B-40	B-40	B-40	B-40	B-40	B-40	B-40	B-40	B-40	B-41	B-41		
Thermal Power Rating P _T		3.0	3.0	4.3	5.8	8.7	12.3	16.8	20.4	24.4	24.7	28.3			

Notes:

1. The high speed shaft speed shall be under 1800 r/min. Consult us when it will be over 1800r/min.
2. When the high speed shaft speed is not shown in the table, find it by the interpolation method.
3. When the high speed shaft speed (n₁) is lower than 750 r/min, find the mechanical power rating (P_N) according to the following formula.

$$P_N = P_{750} \times \frac{N}{750}$$

4. Shown in the table are the ratings for the high speed shaft of reducer.
5. The thermal power ratings (P_T) are applicable to continuous operation at ambient temperatures of 20°C or less.



Unit: kW

		Size of Reducer												
1120	1130	1140	1150	1160	1170	1180	1185	1190	1195	1200	1205	1210	1215	1220
246.4	246.4													
32.5	43.9													
27.1	36.6													
21.7	29.3													
18.1	24.4													
16.3	22.0													
13.6	18.3													
*278.6	*278.6													
28.8	38.8													
24.0	32.4													
19.2	25.9													
16.0	21.6													
14.4	19.4													
12.0	16.2													
326.1	326.1													
24.6	33.2													
20.5	27.7													
16.4	22.1													
13.7	18.4													
12.3	16.6													
10.2	13.8													
*368.8	*368.8		371.3	371.3	378.0					360.8				
21.7	29.4		51.8	68.5	83.5					228.0				
18.1	24.5		43.3	57.2	69.7					190.0				
14.5	19.6		34.7	45.9	55.9					151.9				
12.1	16.3		29.0	38.3	46.7					126.6				
10.9	14.7		26.1	34.5	42.0					113.9				
9.1	12.2		21.8	28.8	35.1					94.9				
*396.9	*396.9	389.0	420.0	420.0	427.5	401.0		401.0	386.8	408.0	386.8	389.6	417.8	389.6
20.2	27.3	38.1	45.9	60.6	73.9	95.0		140.0	181.4	201.0	238.4	288.0	313.3	386.0
16.8	22.7	31.8	38.3	50.6	61.7	79.1		117.0	151.2	168.0	198.7	240.0	261.7	322.0
13.5	18.2	25.4	30.7	40.6	49.5	63.3		93.3	120.9	134.3	158.9	192.1	210.0	257.2
11.2	15.2	21.2	25.6	33.9	41.3	52.8		77.8	100.8	111.9	132.4	160.1	175.4	214.4
10.1	13.6	19.1	23.1	30.5	37.2	47.5		70.0	90.7	100.7	119.2	144.1	158.0	192.9
8.4	11.4	15.9	19.3	25.5	31.1	39.6		58.3	75.6	83.9	99.3	120	131.9	160.8
462.0	462.0	*440.0	452.0	452.0	460.0	453.6	430.0	453.6	437.5	447.9	437.5	440.7	472.5	440.7
17.4	23.4	33.7	42.7	56.4	68.7	84.0	92.4	124.0	160.4	183.0	210.8	255.0	277.5	341.0
14.5	19.5	28.1	35.6	47.1	57.4	70.0	79.6	103.0	133.7	152.9	175.7	212.0	231.8	284.0
11.6	15.6	22.5	28.6	37.8	46.0	56.0	66.3	82.5	106.9	122.3	140.5	169.8	185.9	227.5
9.6	13.0	18.7	23.8	31.5	38.4	46.7	57.1	68.8	89.1	101.9	117.1	141.5	155.3	189.5
8.7	11.7	16.9	21.5	28.4	34.6	42.0	52.4	61.9	80.2	91.7	105.4	127.4	139.9	170.6
7.2	9.8	14.0	17.9	23.7	28.9	35.0	44.7	51.6	66.8	76.5	87.8	106.1	116.7	142.2
B-35	B-35	B-35												
B-41	B-41	B-41	B-41	B-41	B-41	B-41	B-41	B-42	B-42	B-42	B-42	B-42	B-42	B-42
34.4	41.3	49.3	59.7	71.4	77.5	87.2	92.6	113	122	143	147	173	174	212

*Those reduction ratios will be available as option. We, however, recommend standard reduction ratio considering extra cost and delivery date.

■ Selection Table Reducer

Reduction ratio	500~900
-----------------	---------

Mechanical Power Rating P_N

Nominal Reduction Ratio	H. Speed Shaft Speed _{n₁} r/min	L. Speed Shaft Speed _{n₂} r/min	Size of Reducer											
			1010	1020	1030	1040	1050	1060	1070	1080	1090	1100	1110	
500	Exact Reduction Ratio									*500.1	*500.1	*554.3	*522.4	
	1800	3.6								4.87	6.20	8.1	11.5	
	1500	3.0								4.06	5.17	6.8	9.6	
	1200	2.4								3.25	4.13	5.5	7.7	
	1000	2.0								2.71	3.45	4.6	6.4	
	900	1.8								2.43	3.10	4.1	5.8	
560	750	1.5								2.03	2.58	3.4	4.8	
	Exact Reduction Ratio		543.8	543.8	543.8	543.8	543.8	543.8	543.8	543.8	543.8	*596.6	*562.2	
	1800	3.2	0.17	0.26	0.39	0.59	1.15	1.96	3.08	4.56	5.70	7.6	10.7	
	1500	2.7	0.14	0.21	0.33	0.49	0.96	1.64	2.57	3.80	4.75	6.4	8.9	
	1200	2.1	0.11	0.17	0.26	0.40	0.77	1.31	2.06	3.04	3.80	5.1	7.1	
	1000	1.8	0.10	0.14	0.22	0.33	0.64	1.09	1.71	2.53	3.17	4.3	5.9	
630	900	1.6	0.09	0.13	0.20	0.30	0.57	0.98	1.54	2.28	2.85	3.8	5.3	
	750	1.3	0.07	0.11	0.16	0.25	0.48	0.82	1.29	1.90	2.38	3.2	4.5	
	Exact Reduction Ratio									*658.3	*658.3	648.7	611.4	
	1800	2.9								3.80	4.76	7.0	9.8	
	1500	2.4								3.17	3.97	5.9	8.2	
	1200	1.9								2.54	3.17	4.7	6.6	
710	1000	1.6								2.11	2.65	3.9	5.5	
	900	1.4								1.90	2.38	3.5	4.9	
	750	1.2								1.58	1.98	2.9	4.1	
	Exact Reduction Ratio									*708.4	*708.4	*734.1	*691.9	
	1800	2.5								3.53	4.42	6.2	8.7	
	1500	2.1								2.94	3.69	5.2	7.2	
800	1200	1.7								2.36	2.95	4.1	5.8	
	1000	1.4								1.96	2.46	3.5	4.8	
	900	1.3								1.77	2.21	3.1	4.3	
	750	1.1								1.47	1.84	2.6	3.6	
	Exact Reduction Ratio		770.4	770.4	770.4	770.4	770.4	770.4	770.4	770.4	770.4	770.4	851.5	802.5
	1800	2.3	0.12	0.18	0.28	0.43	0.82	1.41	2.21	3.27	4.09	5.3	7.5	
900	1500	1.9	0.10	0.15	0.23	0.35	0.69	1.17	1.84	2.72	3.41	4.5	6.2	
	1200	1.5	0.08	0.12	0.19	0.28	0.55	0.94	1.47	2.18	2.73	3.6	5.0	
	1000	1.3	0.07	0.10	0.16	0.24	0.46	0.78	1.23	1.81	2.27	3.0	4.2	
	900	1.1	0.06	0.09	0.14	0.21	0.41	0.70	1.11	1.63	2.04	2.7	3.7	
	750	0.9	0.05	0.08	0.12	0.18	0.34	0.59	0.92	1.36	1.70	2.2	3.1	
	Exact Reduction Ratio									*871.7	*871.7	919.0	866.2	
Dimension Tables	1800	2.0								2.90	3.63	5.0	6.9	
	1500	1.7								2.42	3.03	4.1	5.8	
	1200	1.3								1.93	2.42	3.3	4.6	
	1000	1.1								1.61	2.02	2.8	3.9	
	900	1.0								1.45	1.82	2.5	3.5	
	750	0.8								1.21	1.51	2.1	2.9	
Horizontal Flange, Horizontal			B-34	B-34	B-34	B-34	B-34	B-34	B-34	B-34	B-34	B-35	B-35	
Thermal Power Rating P _T			B-40	B-40	B-40	B-40	B-40	B-40	B-40	B-40	B-40	B-41	B-41	
			3.0	3.0	4.3	5.8	8.7	12.3	16.8	20.4	24.4	24.7	28.3	

Notes:

1. The high speed shaft speed shall be under 1800 r/min. Consult us when it will be over 1800r/min.
2. When the high speed shaft speed is not shown in the table, find it by the interpolation method.
3. When the high speed shaft speed (n₁) is lower than 750 r/min, find the mechanical power rating (P_N) according to the following formula.

$$P_N = P_{750} \times \frac{N}{750}$$

4. Shown in the table are the ratings for the high speed shaft of reducer.
5. The thermal power ratings (P_T) are applicable to continuous operation at ambient temperatures of 20°C or less.



Unit: kW

Size of Reducer														
1120	1130	1140	1150	1160	1170	1180	1185	1190	1195	1200	1205	1210	1215	1220
*522.4	*522.4	*473.5	491.5	491.5	500.2	488.1	486.3	488.1	470.8	512.8	480.2	483.8	518.7	483.8
15.3	20.7	31.3	39.3	51.9	63.3	78.0	83.6	115.0	149.0	160.3	192.0	232.0	253.1	311.0
12.8	17.3	26.1	32.8	43.3	52.8	65.0	72.0	95.8	124.2	133.6	160.0	193.4	211.4	259.0
10.2	13.8	20.9	26.3	34.7	42.4	52.0	60.0	76.7	99.4	106.8	128.0	154.7	169.6	207.2
8.5	11.5	17.4	21.9	29.0	35.4	43.4	51.7	63.9	82.8	89.0	106.7	128.9	141.6	172.7
7.7	10.4	15.7	19.8	26.1	31.9	39.0	47.4	57.5	74.5	80.1	96.0	116.0	127.5	155.4
6.4	8.6	13.1	16.5	21.8	26.6	32.5	39.5	47.9	62.1	66.8	80.0	96.7	106.3	129.5
*562.2	*562.2	514.9	571.9	571.9	551.2	530.8	569.1	570.0	549.8	555.7	549.8	553.8	593.8	553.8
14.3	19.3	28.8	33.8	44.7	57.5	71.8	73.5	98.5	127.6	147.9	167.7	202.7	221.4	271.5
11.9	16.0	24.0	28.2	37.3	48.0	59.8	63.3	82.1	106.3	123.3	139.8	168.9	184.9	226.2
9.5	12.8	19.2	22.6	29.9	38.5	47.8	52.7	65.6	85.1	98.6	111.8	135.1	148.3	181.0
7.9	10.7	16.0	18.9	25.0	32.1	39.9	45.0	54.7	70.9	82.2	93.2	112.6	123.8	150.8
7.1	9.6	14.4	17.0	22.5	28.9	35.9	40.5	49.2	63.8	74.0	83.9	101.3	111.4	135.7
5.9	8.0	12.0	14.2	18.8	24.1	29.9	33.8	41.0	53.2	61.6	69.9	84.5	92.8	113.1
611.4	611.4	*599.2	626.6	626.6	617.8	584.8	627.0	617.7	652.7	608.8	652.7	600.1	643.4	600.1
13.1	17.7	24.8	30.9	40.8	51.3	65.1	67.9	90.9	107.7	135.0	141.3	187.1	204.6	250.5
10.9	14.8	20.6	25.8	34.1	42.9	54.3	58.5	75.7	89.6	112.5	117.7	155.9	170.8	208.8
8.7	11.8	16.5	20.7	27.3	34.4	43.4	48.7	60.6	71.7	90.0	94.2	124.7	137.0	167.0
7.3	9.8	13.8	17.2	22.8	28.7	36.2	40.9	50.5	59.7	75.0	78.5	103.9	114.2	139.2
6.6	8.9	12.4	15.5	20.5	25.8	32.6	36.8	45.4	53.7	67.5	70.6	93.5	102.8	125.3
5.5	7.4	10.3	12.9	17.1	21.6	27.1	30.6	37.9	44.8	56.2	58.9	77.9	85.7	104.4
*691.9	*691.9	*656.5	696.2	696.2	708.7	655.5	702.8	676.8	725.3	676.5	725.3	657.5	705.0	657.5
11.6	15.6	22.6	27.8	36.8	44.8	58.1	61.8	82.9	96.7	121.5	127.1	170.7	186.9	228.7
9.7	13.0	18.8	23.2	30.7	37.4	48.4	53.2	69.1	80.6	101.2	106.0	142.3	156.1	190.5
7.7	10.4	15.1	18.6	24.6	30.0	38.7	43.7	55.3	64.5	81.0	84.8	113.8	125.1	152.4
6.4	8.7	12.6	15.5	20.5	25.0	32.3	36.4	46.1	53.7	67.5	70.6	94.8	104.3	127.0
5.8	7.8	11.3	14.0	18.5	22.5	29.1	32.8	41.5	48.4	60.7	63.6	85.4	93.8	114.3
4.8	6.5	9.4	11.6	15.4	18.8	24.2	27.3	34.6	40.3	50.6	53.0	71.1	78.2	95.3
802.5	*802.5	729.4	787.9	787.9	801.9	751.9	806.2	751.9	820.7	765.5	820.7	730.6	783.3	730.6
10.0	13.5	20.3	24.6	32.5	39.7	50.7	55.3	74.6	85.5	107.4	112.4	153.7	168.4	205.8
8.3	11.2	16.9	20.5	27.2	33.1	42.2	47.6	62.2	71.2	89.5	93.6	128.0	140.6	171.5
6.7	9.0	13.6	16.5	21.8	26.5	33.8	38.1	49.8	57.0	71.6	74.9	102.4	112.6	137.2
5.6	7.5	11.3	13.7	18.2	22.1	28.1	31.8	41.5	47.5	59.7	62.4	85.4	93.8	114.3
5.0	6.7	10.2	12.3	16.4	19.9	25.3	28.6	37.3	42.7	53.7	56.2	76.8	84.5	102.9
4.2	5.6	8.5	10.3	13.6	16.6	21.1	23.8	31.1	35.6	44.7	46.8	64.0	70.4	85.7
866.2	866.2	*825.4	913.8	913.8	930.1	850.9	912.3	850.9	987.9	926.7	987.9	826.7	886.3	826.7
9.3	12.5	18.0	21.2	28.1	34.2	44.8	49.9	66.0	77.1	92.6	97.1	135.8	149.0	181.9
7.7	10.4	15.0	17.7	23.4	28.6	37.3	42.1	55.0	64.1	77.1	81.6	113.2	124.4	151.6
6.2	8.3	12.0	14.2	18.8	22.9	29.8	33.7	44.0	51.1	61.7	65.2	90.5	99.5	121.2
5.1	6.9	10.0	11.8	15.7	19.1	24.9	28.1	36.6	42.7	51.4	54.9	75.4	82.9	101.0
4.6	6.2	9.0	10.6	14.1	17.2	22.4	25.3	33.0	38.7	46.3	49.8	67.9	74.6	90.9
3.9	5.2	7.5	8.9	11.8	14.4	18.7	21.1	27.5	32.6	38.6	42.1	56.6	62.2	75.8
B-35	B-35	B-35												
B-41	B-41	B-41	B-41	B-41	B-41	B-41	B-41	B-42	B-42	B-42	B-42	B-42	B-42	B-42
34.4	41.3	49.3	59.7	71.4	77.5	87.2	92.6	113	122	143	147	173	174	212

*Those reduction ratios will be available as option. We, however, recommend standard reduction ratio considering extra cost and delivery date.

■ Selection Table Reducer

Reduction ratio	1000~1400
-----------------	-----------

Mechanical Power Rating P_N

Nominal Reduction Ratio	H. Speed Shaft Speed _{n₁} r/min	L. Speed Shaft Speed _{n₂} r/min	Size of Reducer											
			1010	1020	1030	1040	1050	1060	1070	1080	1090	1100	1110	
1000	Exact Reduction Ratio									*1011	*1011	*1040	*980.1	
	1800	1.8								2.50	3.13	4.4	6.1	
	1500	1.5								2.09	2.61	3.7	5.1	
	1200	1.2								1.67	2.09	2.9	4.1	
	1000	1.0								1.39	1.74	2.4	3.4	
	900	0.9								1.25	1.57	2.2	3.1	
	750	0.8							1.04	1.31	1.8	2.6		
1120	Exact Reduction Ratio		1091	1091	1091	1091	1091	1091	1091	1091	1091	1206	1137	
	1800	1.6	0.09	0.13	0.20	0.31	0.59	1.01	1.59	2.34	2.93	3.8	5.3	
	1500	1.3	0.07	0.11	0.17	0.25	0.49	0.84	1.32	1.95	2.44	3.2	4.4	
	1200	1.1	0.06	0.09	0.13	0.20	0.39	0.67	1.06	1.56	1.96	2.5	3.5	
	1000	0.9	0.05	0.07	0.11	0.17	0.33	0.56	0.88	1.30	1.63	2.1	2.9	
	900	0.8	0.04	0.06	0.10	0.15	0.30	0.50	0.79	1.17	1.47	1.9	2.6	
	750	0.7	0.04	0.05	0.08	0.13	0.25	0.42	0.66	0.98	1.22	1.6	2.2	
1250	Exact Reduction Ratio									*1235	*1235			
	1800	1.4								2.09	2.62			
	1500	1.2								1.74	2.18			
	1200	1.0								1.39	1.75			
	1000	0.8								1.16	1.45			
	900	0.7								1.05	1.31			
	750	0.6							0.87	1.09				
1400	Exact Reduction Ratio		1432	1432	1432	1432	1432	1432	1432	1432	1432			
	1800	1.3	0.07	0.10	0.15	0.23	0.46	0.82	1.23	1.82	2.28			
	1500	1.1	0.05	0.08	0.13	0.20	0.38	0.65	1.03	1.52	1.90			
	1200	0.9	0.04	0.07	0.10	0.16	0.31	0.52	0.82	1.21	1.52			
	1000	0.7	0.04	0.05	0.08	0.13	0.25	0.44	0.69	1.01	1.27			
	900	0.6	0.03	0.05	0.08	0.12	0.23	0.39	0.62	0.91	1.14			
	750	0.5	0.03	0.04	0.06	0.10	0.19	0.33	0.51	0.76	0.95			
Dimension Tables	Horizontal Flange, Horizontal		B-34	B-34	B-34	B-34	B-34	B-34	B-34	B-34	B-34	B-34	B-35	B-35
			B-40	B-40	B-40	B-40	B-40	B-40	B-40	B-40	B-40	B-40	B-41	B-41
Thermal Power Rating P_T			3.0	3.0	4.3	5.8	8.7	12.3	16.8	20.4	24.4	24.7	28.3	

Notes:

1. The high speed shaft speed shall be under 1800 r/min. Consult us when it will be over 1800r/min.
2. When the high speed shaft speed is not shown in the table, find it by the interpolation method.
3. When the high speed shaft speed (n_1) is lower than 750 r/min, find the mechanical power rating (P_N) according to the following formula.

$$P_N = P_{750} \times \frac{N}{750}$$

4. Shown in the table are the ratings for the high speed shaft of reducer.
5. The thermal power ratings (P_T) are applicable to continuous operation at ambient temperatures of 20°C or less.



Unit: kW

Size of Reducer														
1120	1130	1140	1150	1160	1170	1180	1185	1190	1195	1200	1205	1210	1215	1220
*980.1	*980.1	957.3	1098	1098	1118	987	1058	986.9	951.9	1067	951.9	958.9	1028	958.9
8.2	11.0	15.5	17.7	23.4	28.5	38.6	43.6	56.9	73.7	77.0	96.9	117.1	128.7	156.8
6.8	9.2	12.9	14.8	19.5	23.8	32.2	36.3	47.4	61.4	64.2	80.7	97.6	107.2	130.7
5.5	7.4	10.3	11.8	15.7	19.1	25.7	29.0	37.9	49.1	51.4	64.6	78.0	85.8	104.5
4.5	6.1	8.6	9.8	13.1	15.9	21.4	24.2	31.6	40.9	42.8	53.8	65.0	71.5	87.1
4.1	5.5	7.7	8.9	11.8	14.3	19.3	21.8	28.4	36.9	38.5	48.4	58.5	64.3	78.4
3.4	4.6	6.5	7.4	9.8	12.0	16.1	18.2	23.7	30.7	32.1	40.4	48.8	53.6	65.3
1137	1137					1186		1186	1144		1144	1152		1152
7.1	9.5					32.1		47.3	61.3		80.6	97.4		130.5
5.9	7.9					26.8		39.4	51.1		67.2	81.2		108.8
4.7	6.3					21.4		31.6	40.9		53.8	65.0		87.0
3.9	5.3					17.8		26.3	34.1		44.8	54.1		72.5
3.5	4.8					16.1		23.7	30.7		40.3	48.7		65.3
2.9	4.0					13.4		19.7	25.6		33.6	40.6		54.4
B-35	B-35	B-35												
B-41	B-41	B-41	B-41	B-41	B-41	B-41	B-41	B-42	B-42	B-42	B-42	B-42	B-42	B-42
34.4	41.3	49.3	59.7	71.4	77.5	87.2	92.6	113	122	143	147	173	174	212

※Those reduction ratios will be available as option. We, however, recommend standard reduction ratio considering extra cost and delivery date.

■ Allowable Radial Loads on Low Speed Shaft

Allowable Radial Load F_{rA} [kN]

Reduction Ratio	5~45
-----------------	------

Shaft Speed (r/min)	Size of Reducer													
	1010	1020	1030	1040	1050	1060	1070	1080	1090	1100	1110	1120	1130	1140
100	5.0	5.4	6.7	8.9	11.7	18.0	23.6	47.5	48.5	92.6	112	132	148	184
60	5.9	6.4	7.9	10.5	13.9	21.3	28.0	56.2	69.4	108	131	154	173	214
40	6.8	7.3	9.0	12.0	16.0	24.4	32.1	64.4	79.4	122	148	174	195	242
20	8.4	9.2	11.3	15.2	21.1	30.8	40.4	80.6	100	150	182	215	240	298
10	8.4	10.9	13.8	19.1	25.4	38.8	50.9	80.6	116	178	224	264	296	366
5	8.4	10.9	13.8	19.4	26.7	42.1	59.8	80.6	116	178	225	269	306	393

Allowable Radial Load F_{rA} [kN]

Reduction Ratio	50~1400
-----------------	---------

Shaft Speed (r/min)	Size of Reducer															
	1010	1020	1030	1040	1050	1060	1070	1080	1090	1100	1110	1120	1130	1140	1150	1160
100	5.0	5.4	6.7	8.9	11.7	18.0	23.6	47.5	48.5	92.6	117	132	167	227	235	378
60	5.9	6.4	7.9	10.5	13.9	21.3	28.0	56.2	69.4	108	136	154	195	264	274	441
40	6.8	7.3	9.0	12.0	16.0	24.4	32.1	64.4	79.4	122	153	174	220	298	310	498
20	8.4	9.2	11.3	15.2	21.1	30.8	40.4	80.6	100	150	189	215	271	367	381	602
10	8.4	10.9	13.8	19.1	25.4	38.8	50.9	80.6	116	178	233	264	333	452	469	602
5	8.4	10.9	13.8	19.4	26.7	42.1	59.8	80.6	116	178	248	269	396	461	498	602

Overhang Factor K_3

Overhang Member	Overhang Factor
Sprocket (Single Row)	1
Sprocket (Double Row)	1.25
Gears	1.25
V-belt	1.5
Flat belt	2.5

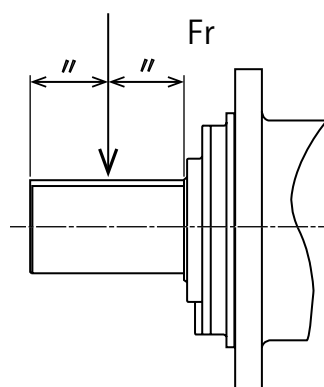

Note: The value shown in the above table is allowable radial load when it is applied to the center of the shaft.

Consult us when a load is not in the center.

In the case of upward radial load, consult us.

■ Allowable Radial Loads on High Speed Shaft

Allowable Radial Load F_{rA} [kN]

Reduction Ratio	5~45
-----------------	------

Shaft Speed (r/min)	Size of Reducer													
	1010	1020	1030	1040	1050	1060	1070	1080	1090	1100	1110	1120	1130	1140
1800	1.1	1.1	1.3	1.3	1.7	1.8	3.0	3.1	3.1	2.7	2.9	3.4	4.2	5.5
1500	1.1	1.1	1.4	1.4	1.8	1.9	3.2	3.3	3.3	2.8	3.1	3.6	4.5	5.8
1200	1.2	1.2	1.5	1.5	1.9	2.0	3.4	3.6	3.6	3.1	3.3	3.9	4.9	6.3
1000	1.3	1.3	1.6	1.6	2.1	2.1	3.6	3.6	3.6	3.3	3.6	4.1	5.2	6.7
900	1.3	1.3	1.6	1.6	2.1	2.1	3.6	3.8	3.8	3.4	3.7	4.2	5.4	6.9
750	1.3	1.3	1.6	1.6	2.1	2.1	3.6	3.8	3.8	3.4	3.7	4.3	5.4	7.0

Allowable Radial Load F_{rA} [kN]

Reduction Ratio	50~224
-----------------	--------

Shaft Speed (r/min)	Size of Reducer (The bottom is shafting)																													
	1010	1020	1030	1040	1050	1060	1070	1080	1090	1100	1110	1120	1130	1140	1150	1160	1170	1180	1185	1190	1195	1200	1205	1210	1215	1220				
	$\phi 30 \phi 35 \phi 35 \phi 40 \phi 40 \phi 50 \phi 40 \phi 50$																													
1800	1.1	1.1	1.1	1.1	1.3	1.3	1.7	1.7	1.8	1.8	3.0	1.8	3.0	1.8	3.0	3.1	3.1	2.8	3.0	3.1	4.6	5.1	5.1	6.3	6.3	7.8	7.8	8.5	8.5	8.6
1500	1.1	1.1	1.1	1.1	1.4	1.4	1.8	1.8	1.9	1.9	3.2	1.9	3.2	1.9	3.2	3.3	3.3	3.0	3.2	3.3	4.8	5.4	5.4	6.7	6.7	8.3	8.3	9.0	9.0	9.2
1200	1.2	1.2	1.2	1.2	1.5	1.5	1.9	1.9	2.0	2.0	3.4	2.0	3.4	2.0	3.4	3.6	3.6	3.2	3.5	3.6	5.2	5.9	5.9	7.2	7.2	9.0	9.0	9.7	9.7	9.9
1000	1.3	1.3	1.3	1.3	1.6	1.6	2.1	2.1	2.1	2.1	3.6	2.1	3.6	2.1	3.6	3.8	3.8	3.4	3.7	3.8	5.5	6.2	6.2	7.7	7.7	9.5	9.5	10.3	10.3	10.5
900	1.3	1.3	1.3	1.3	1.6	1.6	2.1	2.1	2.1	2.1	3.6	2.1	3.6	2.1	3.6	3.8	3.8	3.5	3.8	3.9	5.7	6.5	6.5	7.9	7.9	9.9	9.9	10.7	10.7	10.9
750	1.3	1.3	1.3	1.3	1.6	1.6	2.1	2.1	2.1	2.1	3.6	2.1	3.6	2.1	3.6	3.8	3.8	3.5	3.9	4.0	5.7	6.5	6.5	8.0	8.0	9.9	9.9	10.8	10.8	11.0

Allowable Radial Load F_{rA} [kN]

Reduction Ratio	250~1400
-----------------	----------

Shaft Speed (r/min)	Size of Reducer (The bottom is shafting)																														
	1010	1020	1030	1040	1050	1060	1070	1080	1090	1100	1110	1120	1130	1140	1150	1160	1170	1180	1185	1190	1195	1200	1205	1210	1215	1220					
	$\phi 30 \phi 35 \phi 35 \phi 40 \phi 40 \phi 50 \phi 40 \phi 50$																														
1800	1.1	1.1	1.1	1.1	1.1	1.3	1.1	1.3	1.3	1.3	1.7	1.7	1.8	1.8	3.0	1.8	3.0	1.8	3.0	3.1	3.1	3.1	3.1	3.1	3.1	3.1	3.4	3.4	4.2	4.2	5.5
1500	1.1	1.1	1.1	1.1	1.1	1.4	1.1	1.4	1.4	1.4	1.8	1.8	1.9	1.9	3.2	1.9	3.2	1.9	3.2	3.3	3.3	3.3	3.3	3.3	3.3	3.3	3.6	3.6	4.5	4.5	5.8
1200	1.2	1.2	1.2	1.2	1.2	1.5	1.2	1.5	1.5	1.5	1.9	1.9	2.0	2.0	3.4	2.0	3.4	2.0	3.4	3.6	3.6	3.6	3.6	3.6	3.6	3.6	3.9	3.9	4.9	4.9	6.3
1000	1.3	1.3	1.3	1.3	1.3	1.6	1.3	1.6	1.6	1.6	1.6	2.1	2.1	2.1	2.1	3.6	2.1	3.6	2.1	3.6	3.8	3.8	3.8	3.8	3.8	3.8	4.1	4.1	5.2	5.2	6.7
900	1.3	1.3	1.3	1.3	1.3	1.6	1.3	1.6	1.6	1.6	1.6	2.1	2.1	2.1	2.1	3.6	2.1	3.6	2.1	3.6	3.8	3.8	3.8	3.8	3.8	3.8	4.2	4.2	5.4	5.4	6.9
750	1.3	1.3	1.3	1.3	1.3	1.6	1.3	1.6	1.6	1.6	1.6	2.1	2.1	2.1	2.1	3.6	2.1	3.6	2.1	3.6	3.8	3.8	3.8	3.8	3.8	3.8	4.3	4.3	5.4	5.4	7.0

Overhang Factor K_3

Overhang Member	Overhang Factor
Sprocket (Single Row)	1
Sprocket (Double Row)	1.25
Gears	1.25
V-belt	1.5
Flat belt	2.5

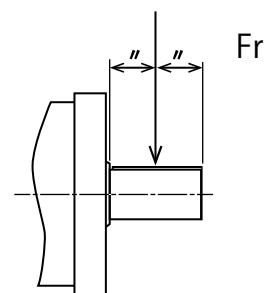

Note: The value shown in the above table is allowable radial load when it is applied to the center of the shaft. Consult us when a load is not in the center.



Dimension Table

DHG TYPE (Horizontal, Inline)	Nominal Reduction Ratio	5 · 9
-------------------------------	-------------------------	-------

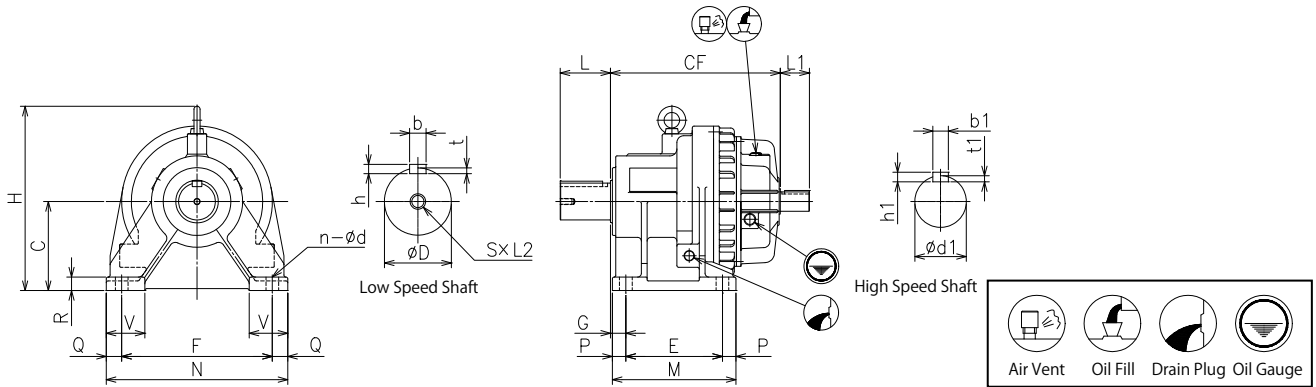

Unit : mm

Size	CF	C	E	F	G	M	N	P	Q	R	V	n	d	H	Mass kg	Oil Qty ℓ
1010	208	105	125	170	20	155	200	15	15	15	45	4	11	212	16	0.3
1020	219	130	140	200	20	170	235	15	17.5	18	52.5	4	14	250	21	0.4
1030	245	155	155	230	25	195	270	20	20	20	60	4	18	284	33	0.5
1040	273	155	165	250	30	215	300	25	25	25	70	4	22	309	48	0.7
1050	312	180	200	300	30	250	350	25	25	30	75	4	22	351	76	0.9
1060	355	205	220	340	35	280	400	30	30	35	100	4	26	415	121	2.0
1070	385	230	250	390	40	320	470	35	40	35	100	4	33	476	168	3.5

Size	Low Speed Shaft							High Speed Shaft				
	D	b	h	t	S	L2	L	d1	b1	h1	t1	L1
1010	40h6	12	8	5	M10	20	55	25h6	8	7	4	35
1020	45h6	14	9	5.5	M12	25	65	25h6	8	7	4	35
1030	50h6	14	9	5.5	M12	25	70	30h6	8	7	4	45
1040	60h6	18	11	7	M12	25	85	35h6	10	8	5	50
1050	70h6	20	12	7.5	M12	25	100	40h6	12	8	5	60
1060	85h6	22	14	9	M16	30	120	50h6	14	9	5.5	75
1070	95h6	25	14	9	M16	30	130	60h6	18	11	7	90

- Appearance may be different from above drawing by size.
- Key is in compliance with parallel key of JIS B1301-1996(ISO).
- Above dimensions and specifications may change without notice.

Nomenclature

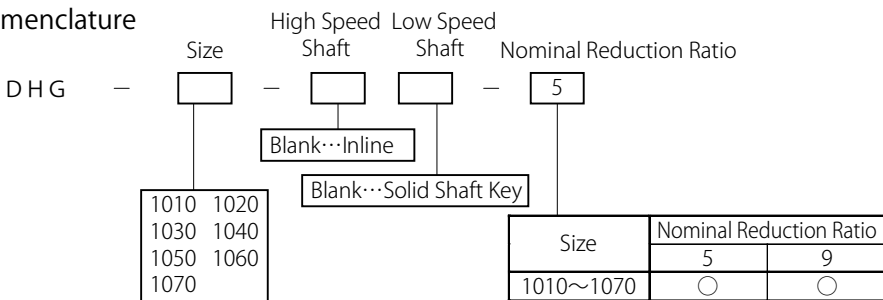

Dimension Table

DHG TYPE (Horizontal, Inline)	Nominal Reduction Ratio	16~45
-------------------------------	-------------------------	-------

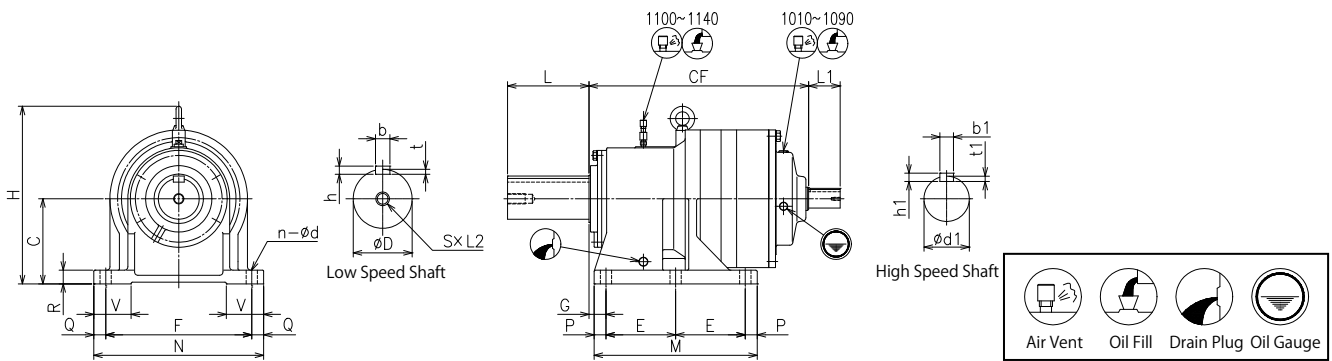

Unit : mm

Size	CF	C	E	F	G	M	N	P	Q	R	V	n	d	H	Mass kg	Oil Qty ℓ
1010	240	105	125	170	20	155	200	15	15	15	45	4	11	212	20	0.4
1020	251	130	140	200	20	170	235	15	17.5	18	52.5	4	14	250	24	0.4
1030	284	155	155	230	25	195	270	20	20	20	60	4	18	284	40	0.6
1040	302	155	165	250	30	215	300	25	25	25	70	4	22	309	51	0.8
1050	354	180	200	300	30	250	350	25	25	30	75	4	22	351	83	1.1
1060	399	205	220	340	35	280	400	30	30	35	100	4	26	415	130	2.2
1070	440	230	250	390	40	320	470	35	40	35	100	4	33	476	189	3.8
1080	497	250	280	450	45	360	540	40	45	35	115	4	33	517	259	4.8
1090	512	250	300	510	55	400	600	50	45	38	135	4	39	557	306	5.9
1100	652	250	205	430	50	480	500	35	35	40	110	6	33	522	372	11.0
1110	700	265	215	460	65	520	550	45	45	45	120	6	39	578	500	14.0
1120	776	280	245	520	65	580	610	45	45	45	135	6	39	618	689	20.0
1130	846	315	265	560	70	630	660	50	50	50	145	6	45	698	900	21.0
1140	940	355	295	620	70	690	720	50	50	50	160	6	45	763	1261	33.0

Size	Low Speed Shaft							High Speed Shaft				
	D	b	h	t	S	L2	L	d1	b1	h1	t1	L1
1010	40h6	12	8	5	M10	20	55	25h6	8	7	4	35
1020	45h6	14	9	5.5	M12	25	65	25h6	8	7	4	35
1030	50h6	14	9	5.5	M12	25	70	30h6	8	7	4	45
1040	60h6	18	11	7	M12	25	85	30h6	8	7	4	45
1050	70h6	20	12	7.5	M12	25	100	35h6	10	8	5	50
1060	85h6	22	14	9	M16	30	120	40h6	12	8	5	60
1070	95h6	25	14	9	M16	30	130	50h6	14	9	5.5	75
1080	105h6	28	16	10	M16	30	145	60h6	18	11	7	90
1090	115h6	32	18	11	M16	30	160	60h6	18	11	7	90
1100	120m6	32	18	11	M30	52	180	60h6	18	11	7	90
1110	130m6	32	18	11	M30	52	200	60h6	18	11	7	90
1120	150m6	36	20	12	M30	52	210	65h6	18	11	7	105
1130	160m6	40	22	13	M36	62	240	70h6	20	12	7.5	120
1140	180m6	45	25	15	M36	62	250	75h6	20	12	7.5	140

- Appearance may be different from above drawing by size.
- Key is in compliance with parallel key of JIS B1301-1996(ISO).
- Above dimensions and specifications may change without notice.

Nomenclature

High Speed Shaft Low Speed Shaft Nominal Reduction Ratio

Size Shaft Shaft

DHG - [] - [] [] - [16]

Blank...Inline

Blank...Solid Shaft Key

1010	1020	1030
1040	1050	1060
1070	1080	1090
1100	1110	1120
1130	1140	

Size	Nominal Reduction Ratio									
	16	18	20	22.4	25	28	31.5	35.5	40	45
1010~1030	○			○			○		○	
1040・1050	○	○	○	○			○	○	○	
1060	○	○	○	○	○	○	○	○	○	
1070~1140	○	○	○	○	○	○	○	○	○	○

Dimension Table

DHG TYPE (Horizontal, Inline)	Nominal Reduction Ratio	50~224
-------------------------------	-------------------------	--------

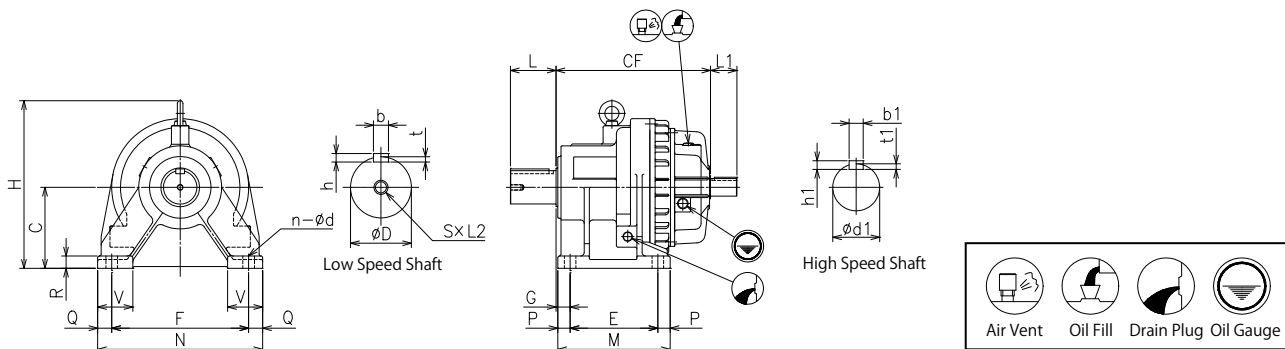

Unit : mm

Size	Nominal Reduction Ratio	CF	C	E	F	G	M	N	P	Q	R	V	n	d	H	Mass kg	Oil Qty ℓ
1010	—	272	105	125	170	20	155	200	15	15	15	45	4	11	212	23	0.4
1020	—	283	130	140	200	20	170	235	15	17.5	18	52.5	4	14	250	28	0.5
1030	—	309	155	155	230	25	195	270	20	20	20	60	4	18	284	41	0.6
1040	—	327	155	165	250	30	215	300	25	25	25	70	4	22	309	53	0.8
1050	—	383	180	200	300	30	250	350	25	25	30	75	4	22	351	86	1.3
1060	50~90	441	205	220	340	35	280	400	30	30	35	100	4	26	415	137	2.5
	100~224	421														129	2.5
1070	50~63	484	230	250	390	40	320	470	35	40	35	100	4	33	476	195	4.5
	71~224	467														183	4.5
1080	50~63	552	250	280	450	45	360	540	40	45	35	115	4	33	517	275	5.7
	71~224	537														263	5.7
1090	50~80	567	250	300	510	55	400	600	50	45	38	135	4	39	557	324	7.0
	90~224	552														310	7.0

Size	Nominal Reduction Ratio	Low Speed Shaft							High Speed Shaft				
		D	b	h	t	S	L2	L	d1	b1	h1	t1	L1
1010	—	40h6	12	8	5	M10	20	55	25h6	8	7	4	35
1020	—	45h6	14	9	5.5	M12	25	65	25h6	8	7	4	35
1030	—	50h6	14	9	5.5	M12	25	70	25h6	8	7	4	35
1040	—	60h6	18	11	7	M12	25	85	25h6	8	7	4	35
1050	—	70h6	20	12	7.5	M12	25	100	30h6	8	7	4	45
1060	50~90	85h6	22	14	9	M16	30	120	35h6	10	8	5	50
	100~224								30h6	8	7	4	45
1070	50~63	95h6	25	14	9	M16	30	130	40h6	12	8	5	60
	71~224								35h6	10	8	5	50
1080	50~63	105h6	28	16	10	M16	30	145	50h6	14	9	5.5	75
	71~224								40h6	12	8	5	60
1090	50~80	115h6	32	18	11	M16	30	160	50h6	14	9	5.5	75
	90~224								40h6	12	8	5	60

- Appearance may be different from above drawing by size.
- Key is in compliance with parallel key of JIS B1301-1996(ISO).
- Above dimensions and specifications may change without notice.

Nomenclature

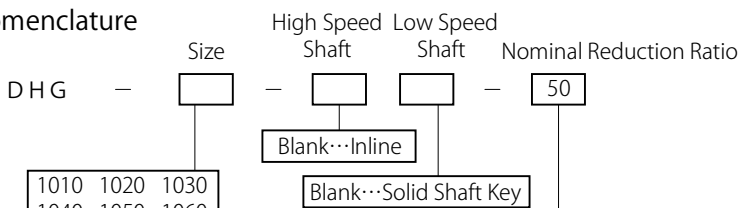

1010	1020	1030
1040	1050	1060
1070	1080	1090

Size	Nominal Reduction Ratio													
	50	56	63	71	80	90	100	112	125	140	160	180	200	224
1010~1040	○			○		○			○			○		○
1050~1090	○	○	○	○	○	○	○	○	○	○	○	○	○	○

Dimension Table

DHG TYPE (Horizontal, Inline)	Nominal Reduction Ratio	71~200
-------------------------------	-------------------------	--------

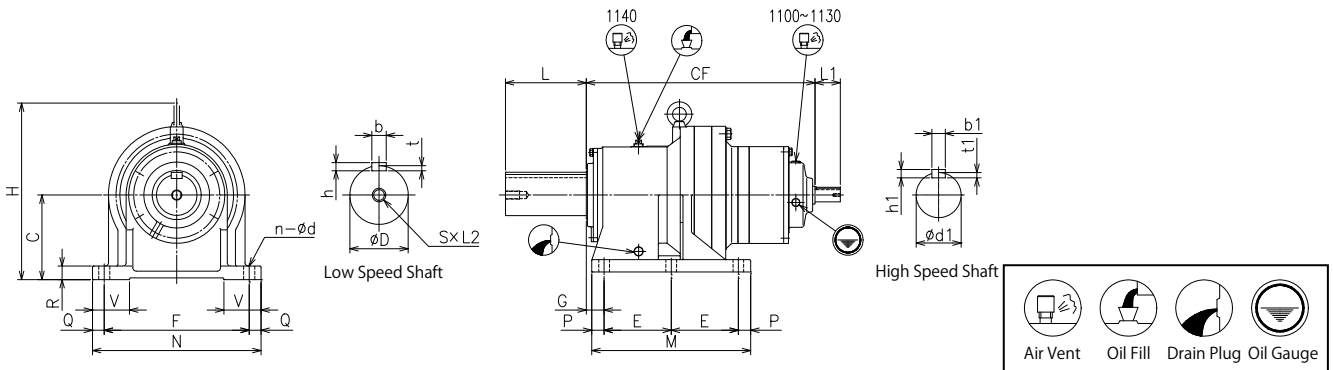

Unit : mm

Size	CF	C	E	F	G	M	N	P	Q	R	V	n	d	H	Mass kg	Oil Qty ℓ
1100	668	250	205	430	50	480	500	35	35	40	110	6	33	522	360	12.0
1110	717	265	215	460	65	520	550	45	45	45	120	6	39	558	470	13.0
1120	795	280	245	520	65	580	610	45	45	45	135	6	39	598	640	16.0
1130	846	315	265	560	70	630	660	50	50	50	145	6	45	677	820	22.0
1140	968	355	295	620	70	690	720	50	50	50	160	6	45	742	1200	34.0

Size	Low Speed Shaft							High Speed Shaft				
	D	b	h	t	S	L2	L	d1	b1	h1	t1	L1
1100	120m6	32	18	11	M30	52	180	40h6	12	8	5	60
1110	130m6	32	18	11	M30	52	200	50h6	14	9	5.5	75
1120	150m6	36	20	12	M30	52	210	60h6	18	11	7	90
1130	160m6	40	22	13	M36	62	240	60h6	18	11	7	90
1140	180m6	45	25	15	M36	62	250	60h6	18	11	7	90

- Appearance may be different from above drawing by size.
- Key is in compliance with parallel key of JIS B1301-1996(ISO).
- Above dimensions and specifications may change without notice.

Nomenclature

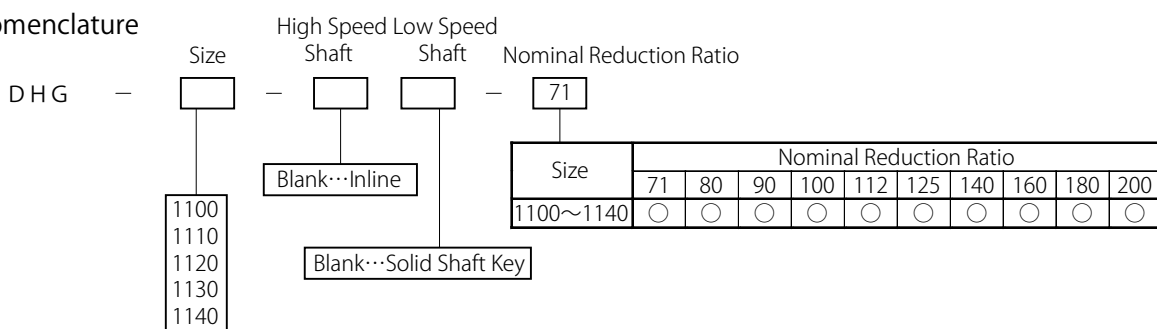

Dimension Table

DHG TYPE (Horizontal, Inline)	Nominal Reduction Ratio	315~1400
-------------------------------	-------------------------	----------

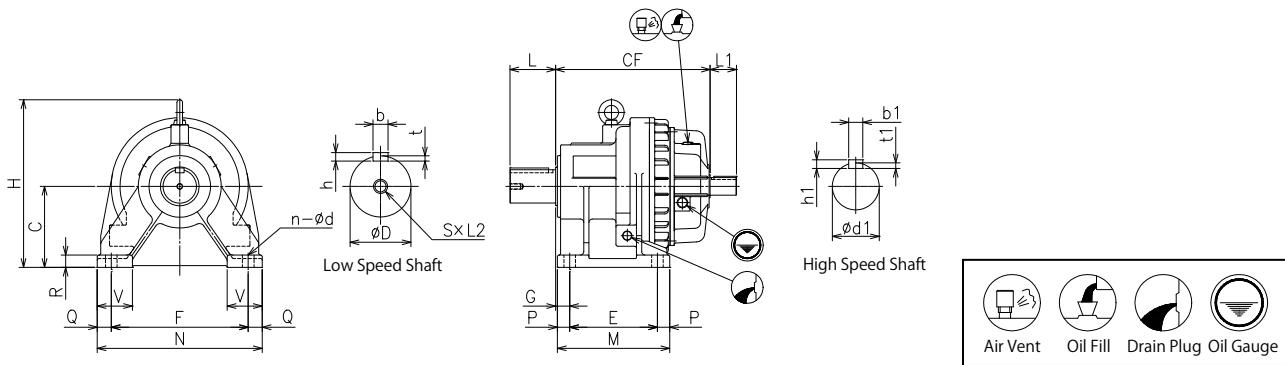

Unit : mm

Size	CF	C	E	F	G	M	N	P	Q	R	V	n	d	H	Mass kg	Oil Qty ℓ
1010	304	105	125	170	20	155	200	15	15	15	45	4	11	212	26	0.4
1020	315	130	140	200	20	170	235	15	17.5	18	52.5	4	14	250	31	0.5
1030	341	155	155	230	25	195	270	20	20	20	60	4	18	284	44	0.7
1040	359	155	165	250	30	215	300	25	25	25	70	4	22	309	56	0.9
1050	401	180	200	300	30	250	350	25	25	30	75	4	22	351	85	1.4
1060	446	205	220	340	35	280	400	30	30	35	100	4	26	415	131	2.7
1070	482	230	250	390	40	320	470	35	40	35	100	4	33	476	182	4.9
1080	559	250	280	450	45	360	540	40	45	35	115	4	33	517	258	6.8
1090	574	250	300	510	55	400	600	50	45	38	135	4	39	557	306	8.0

Size	Low Speed Shaft							High Speed Shaft				
	D	b	h	t	S	L2	L	D1	b1	h1	t1	L1
1010	40h6	12	8	5	M10	20	55	25h6	8	7	4	35
1020	45h6	14	9	5.5	M12	25	65	25h6	8	7	4	35
1030	50h6	14	9	5.5	M12	25	70	25h6	8	7	4	35
1040	60h6	18	11	7	M12	25	85	25h6	8	7	4	35
1050	70h6	20	12	7.5	M12	25	100	25h6	8	7	4	35
1060	85h6	22	14	9	M16	30	120	25h6	8	7	4	35
1070	95h6	25	14	9	M16	30	130	25h6	8	7	4	35
1080	105h6	28	16	10	M16	30	145	30h6	8	7	4	45
1090	115h6	32	18	11	M16	30	160	30h6	8	7	4	45

- Appearance may be different from above drawing by size.
- Key is in compliance with parallel key of JIS B1301-1996(ISO).
- Above dimensions and specifications may change without notice.

Nomenclature

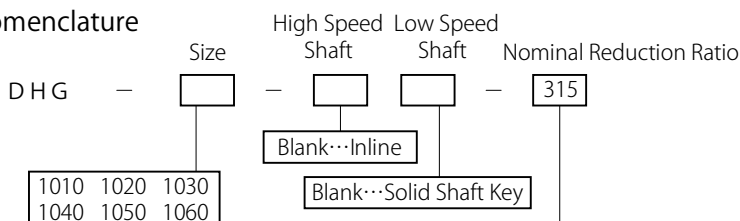

1010	1020	1030
1040	1050	1060
1070	1080	1090

Size	Nominal Reduction Ratio												
	315	355	400	450	500	560	630	710	900	1000	1120	1250	1400
1010~1070	○		○			○			○		○		○
1080・1090	○	○	○	○	○	○	○	○	○	○	○	○	○

Dimension Table

DHG TYPE (Horizontal, Inline)	Nominal Reduction Ratio	250~1120
-------------------------------	-------------------------	----------

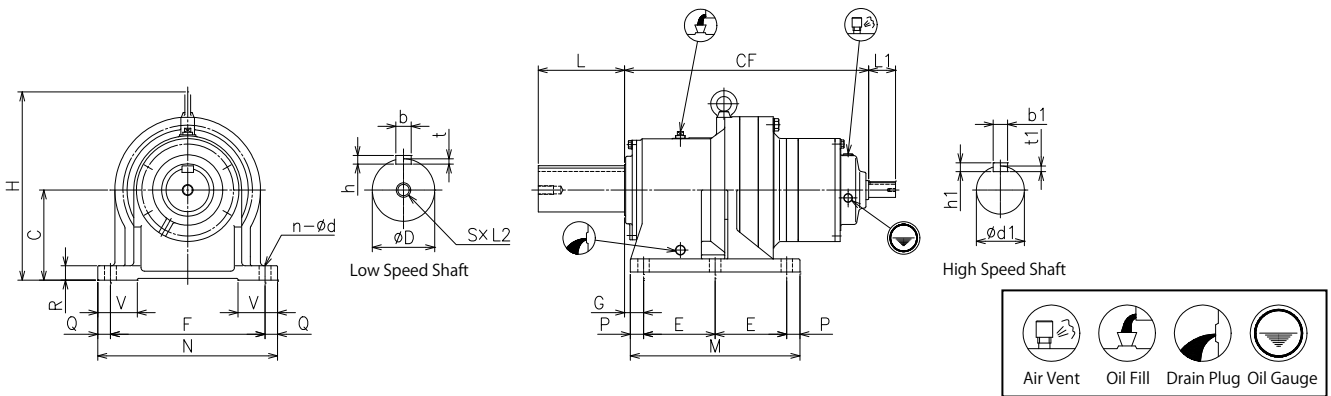

Unit : mm

Size	Nominal Reduction Ratio	CF	C	E	F	G	M	N	P	Q	R	V	n	d	H	Mass kg	Oil Qty ℓ
1100	250~450	710	250	205	430	50	480	500	35	35	40	110	6	33	522	370	13.0
	500~1120	690															
1110	250 · 280	761	265	215	460	65	520	550	45	45	45	120	6	39	558	480	14.0
	315~1120	744															
1120	250 · 280	850	280	245	520	65	580	610	45	45	45	135	6	39	598	650	17.0
	315~1120	835															
1130	250~400	901	315	265	560	70	630	660	50	50	50	145	6	45	677	825	23.0
	450~1120	886															
1140	—	984	355	295	620	70	690	720	50	50	50	160	6	45	742	1210	34.5

Size	Nominal Reduction Ratio	Low Speed Shaft							High Speed Shaft				
		D	b	h	t	S	L2	L	d1	b1	h1	t1	L1
1100	250~450	120m6	32	18	11	M30	52	180	35h6	10	8	5	50
	30h6								8	7	4	45	
1110	250 · 280	130m6	32	18	11	M30	52	200	40h6	12	8	5	60
	35h6								10	8	5	50	
1120	250 · 280	150m6	36	20	12	M30	52	210	50h6	14	9	5.5	75
	40h6								12	8	5	60	
1130	250~400	160m6	40	22	13	M36	62	240	50h6	14	9	5.5	75
	40h6								12	8	5	60	
1140	—	180m6	45	25	15	M36	62	250	40h6	12	8	5	60

- Appearance may be different from above drawing by size.
- Key is in compliance with parallel key of JIS B1301-1996(ISO).
- Above dimensions and specifications may change without notice.

Nomenclature

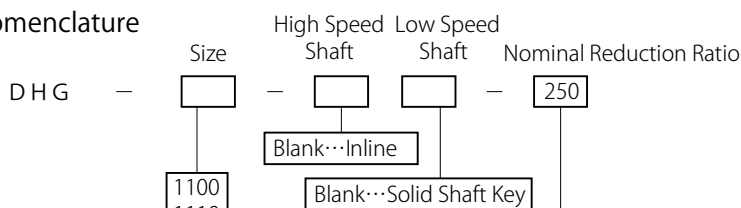

Size	Nominal Reduction Ratio														
	250	280	315	355	400	450	500	560	630	710	800	900	1000	1120	
1100	○	○	○	○	○	○	○	○	○	○	○	○	○	○	
1110	○	○	○	○	○	○	○	○	○	○	○	○	○	○	
1120	○	○	○	○	○	○	○	○	○	○	○	○	○	○	
1130	○	○	○	○	○	○	○	○	○	○	○	○	○	○	
1140					○	○	○	○	○	○	○	○	○	○	



Dimension Table

DHF TYPE (Horizontal Flange, Inline)	Nominal Reduction Ratio	5 · 9
--------------------------------------	-------------------------	-------

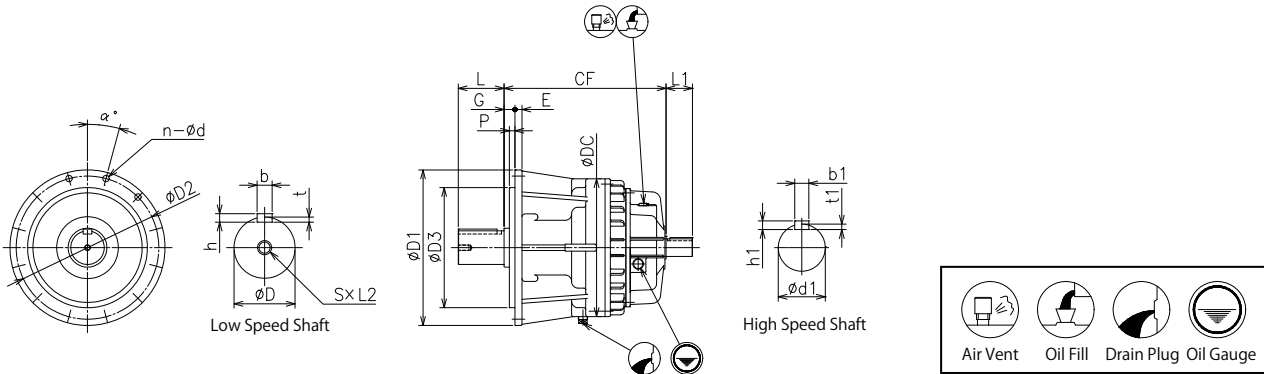

Unit : mm

Size	CF	D1	D2	D3	E	G	P	n	d	α	DC	Mass kg	Oil Qty ℓ
1010	208	200	175	130h7	12	10	5	6	12	30	166	15	0.3
1020	219	220	195	150h7	12	10	5	6	12	30	166	18	0.4
1030	245	245	215	170h7	16	10	5	6	14	30	200	28	0.5
1040	273	275	245	200h7	16	10	5	6	14	30	230	42	0.7
1050	312	315	285	240h7	16	10	5	6	14	30	280	64	0.9
1060	355	390	355	290h7	20	11	6	6	18	30	335	112	2.0
1070	385	440	405	340h7	20	11	6	8	18	22.5	390	165	3.5

Size	Low Speed Shaft							High Speed Shaft				
	D	b	h	t	S	L2	L	d1	b1	h1	t1	L1
1010	40h6	12	8	5	M10	20	55	25h6	8	7	4	35
1020	45h6	14	9	5.5	M12	25	65	25h6	8	7	4	35
1030	50h6	14	9	5.5	M12	25	70	30h6	8	7	4	45
1040	60h6	18	11	7	M12	25	85	35h6	10	8	5	50
1050	70h6	20	12	7.5	M12	25	100	40h6	12	8	5	60
1060	85h6	22	14	9	M16	30	120	50h6	14	9	5.5	75
1070	95h6	25	14	9	M16	30	130	60h6	18	11	7	90

- Appearance may be different from above drawing by size.
- Key is in compliance with parallel key of JIS B1301-1996(ISO).
- Above dimensions and specifications may change without notice.

Nomenclature

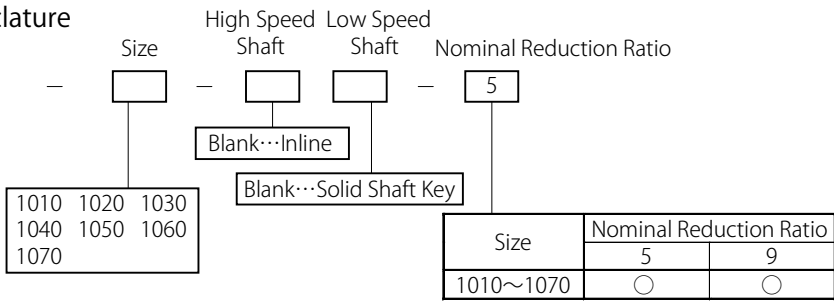

Dimension Table

DHF TYPE (Horizontal Flange, Inline)	Nominal Reduction Ratio	16~45
--------------------------------------	-------------------------	-------

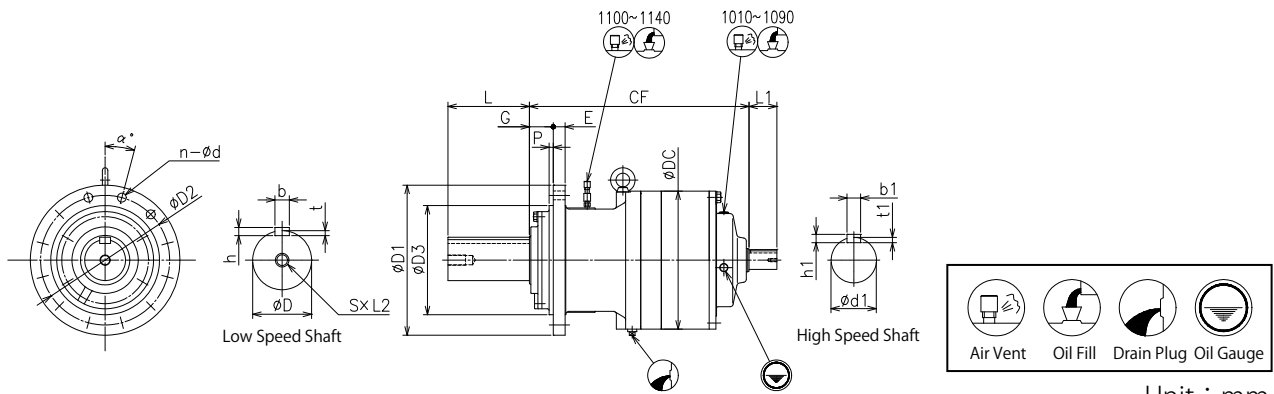

Unit : mm

Size	CF	D1	D2	D3	E	G	P	n	d	a	DC	Mass kg	Oil Qty ℓ
1010	240	200	175	130h7	12	10	5	6	12	30	166	19	0.4
1020	251	220	195	150h7	12	10	5	6	12	30	166	21	0.4
1030	284	245	215	170h7	16	10	5	6	14	30	200	35	0.6
1040	302	275	245	200h7	16	10	5	6	14	30	230	45	0.8
1050	354	315	285	240h7	16	10	5	6	14	30	280	72	1.1
1060	399	390	355	290h7	20	11	6	6	18	30	335	120	2.2
1070	440	440	405	340h7	20	11	6	8	18	22.5	390	186	3.8
1080	497	505	460	390h7	25	13	8	8	22	22.5	430	269	4.8
1090	512	545	500	430h7	25	13	8	8	22	22.5	470	293	5.9
1100	652	440	380	320f8	35	70	12	12	26	15	405	332	8.3
1110	700	480	420	360f8	35	70	13	12	26	15	450	452	10
1120	776	530	460	390f8	40	80	13	12	33	15	500	637	15
1130	846	580	510	440f8	40	90	14	12	33	15	550	761	15
1140	940	650	560	470f8	45	90	14	12	39	15	600	1020	22

Size	Low Speed Shaft							High Speed Shaft				
	D	b	h	t	S	L2	L	d1	b1	h1	t1	L1
1010	40h6	12	8	5	M10	20	55	25h6	8	7	4	35
1020	45h6	14	9	5.5	M12	25	65	25h6	8	7	4	35
1030	50h6	14	9	5.5	M12	25	70	30h6	8	7	4	45
1040	60h6	18	11	7	M12	25	85	30h6	8	7	4	45
1050	70h6	20	12	7.5	M12	25	100	35h6	10	8	5	50
1060	85h6	22	14	9	M16	30	120	40h6	12	8	5	60
1070	95h6	25	14	9	M16	30	130	50h6	14	9	5.5	75
1080	105h6	28	16	10	M16	30	145	60h6	18	11	7	90
1090	115h6	32	18	11	M16	30	160	60h6	18	11	7	90
1100	120m6	32	18	11	M30	52	180	60h6	18	11	7	90
1110	130m6	32	18	11	M30	52	200	60h6	18	11	7	90
1120	150m6	36	20	12	M30	52	210	65h6	18	11	7	105
1130	160m6	40	22	13	M36	62	240	70h6	20	12	7.5	120
1140	180m6	45	25	15	M36	62	250	75h6	20	12	7.5	140

- Appearance may be different from above drawing by size.
- Key is in compliance with parallel key of JIS B1301-1996(ISO).
- Above dimensions and specifications may change without notice.

Nomenclature

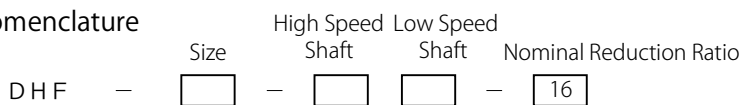

1010 1020 1030 1040 1050 1060 1070 1080 1090 1100 1110 1120 1130 1140	Blank...Inline	Blank...Solid Shaft Key	Nominal Reduction Ratio											
			Size	16	18	20	22.4	25	28	31.5	35.5	40	45	
			1010~1030	○			○			○		○		
			1040・1050	○	○	○	○			○	○	○		
			1060	○	○	○	○	○	○	○	○	○	○	
			1070~1140	○	○	○	○	○	○	○	○	○	○	○



Dimension Table

DHF TYPE (Horizontal Flange, Inline)	Nominal Reduction Ratio	50~224
--------------------------------------	-------------------------	--------

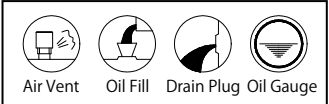
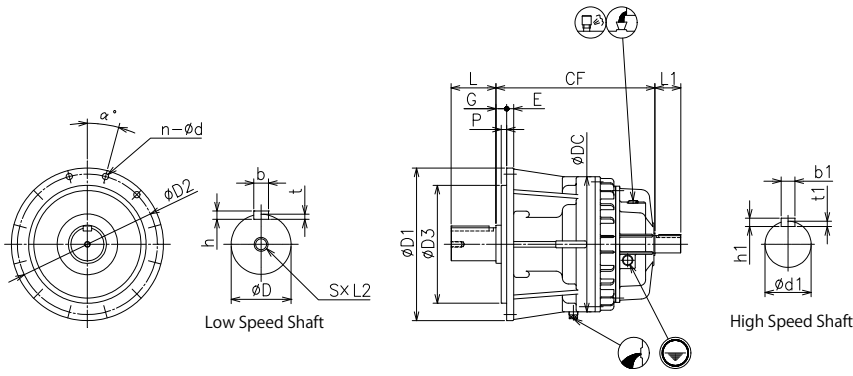

Unit : mm

Size	Nominal Reduction Ratio	CF	D1	D2	D3	E	G	P	n	d	a	DC	Mass kg	Oil Qty ℓ
1010	—	272	200	175	130h7	12	10	5	6	12	30	166	22	0.4
1020	—	283	220	195	150h7	12	10	5	6	12	30	166	25	0.5
1030	—	309	245	215	170h7	16	10	5	6	14	30	200	36	0.6
1040	—	327	275	245	200h7	16	10	5	6	14	30	230	46	0.8
1050	—	383	315	285	240h7	16	10	5	6	14	30	280	74	1.3
1060	50~90	441	390	355	290h7	20	11	6	6	18	30	335	127	2.5
	100~224	421	390	355	290h7	20	11	6	6	18	30	335	120	2.5
1070	50~63	484	440	405	340h7	20	11	6	8	18	22.5	390	192	4.5
	71~224	467	440	405	340h7	20	11	6	8	18	22.5	390	180	4.5
1080	50~63	552	505	460	390h7	25	13	8	8	22	22.5	430	286	5.7
	71~224	537	505	460	390h7	25	13	8	8	22	22.5	430	269	5.7
1090	50~80	567	545	500	430h7	25	13	8	8	22	22.5	470	310	7.0
	90~224	552	545	500	430h7	25	13	8	8	22	22.5	470	297	7.0

Size	Nominal Reduction Ratio	Low Speed Shaft							High Speed Shaft				
		D	b	h	t	S	L2	L	d1	b1	h1	t1	L1
1010	—	40h6	12	8	5	M10	20	55	25h6	8	7	4	35
1020	—	45h6	14	9	5.5	M12	25	65	25h6	8	7	4	35
1030	—	50h6	14	9	5.5	M12	25	70	25h6	8	7	4	35
1040	—	60h6	18	11	7	M12	25	85	25h6	8	7	4	35
1050	—	70h6	20	12	7.5	M12	25	100	30h6	8	7	4	45
1060	50~90	85h6	22	14	9	M16	30	120	35h6	10	8	5	50
	100~224	85h6	22	14	9	M16	30	120	30h6	8	7	4	45
1070	50~63	95h6	25	14	9	M16	30	130	40h6	12	8	5	60
	71~224	95h6	25	14	9	M16	30	130	35h6	10	8	5	50
1080	50~63	105h6	28	16	10	M16	30	145	50h6	14	9	5.5	75
	71~224	105h6	28	16	10	M16	30	145	40h6	12	8	5	60
1090	50~80	115h6	32	18	11	M16	30	160	50h6	14	9	5.5	75
	90~224	115h6	32	18	11	M16	30	160	40h6	12	8	5	60

- Appearance may be different from above drawing by size.
- Key is in compliance with parallel key of JIS B1301-1996 (ISO).
- Above dimensions and specifications may change without notice.

Nomenclature

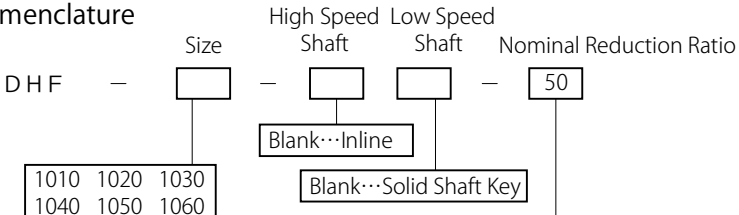

1010	1020	1030
1040	1050	1060
1070	1080	1090

Size	Nominal Reduction Ratio													
	50	56	63	71	80	90	100	112	125	140	160	180	200	224
1010~1040	○			○		○			○			○		○
1050~1090	○	○	○	○	○	○	○	○	○	○	○	○	○	○

Dimension Table

DHF TYPE (Horizontal Flange, Inline)	Nominal Reduction Ratio	71~224
--------------------------------------	-------------------------	--------

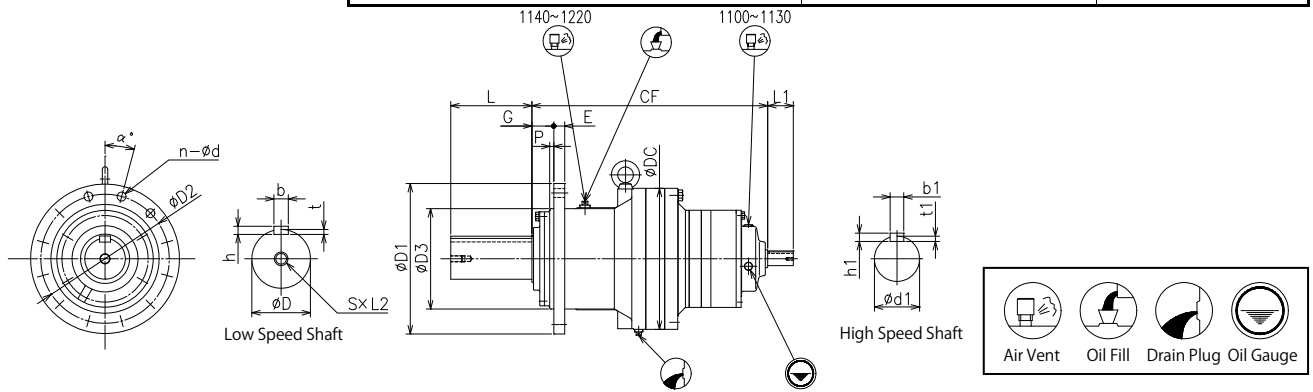

Unit : mm

Size	CF	D1	D2	D3	E	G	P	n	d	a	DC	Mass kg	Oil Qty ℓ
1100	668	440	380	320f8	35	70	12	12	26	15	405	320	9
1110	717	540	480	420f8	35	75	15	12	26	15	410	422	9.5
1120	795	570	510	450f8	40	80	15	16	26	11.25	460	610	11
1130	846	625	555	485f8	40	90	15	16	33	11.25	510	690	16
1140	968	675	605	535f8	45	100	15	20	33	9	560	880	15
1150	1050	760	670	580f8	45	110	20	16	39	11.25	600	1190	18
1160	1189	810	720	630f8	50	120	20	20	39	9	650	1380	22
1170	1254	870	780	680f8	55	120	20	24	39	7.5	680	1780	25
1180	1315	930	840	730f8	55	120	20	24	39	7.5	730	2490	28
1185	1338	1000	910	800f8	55	120	20	30	39	6	805	2800	35
1190	1470	1050	950	830f8	60	125	20	24	45	7.5	835	3230	40
1195	1521	1100	1000	880f8	60	125	20	30	45	6	890	3550	46
1200	1604	1180	1070	940f8	65	130	20	24	52	7.5	940	4820	52
1205	1636	1220	1110	980f8	65	130	20	24	52	7.5	980	5610	58
1210	1810	1300	1190	1050f8	70	145	20	24	52	7.5	1030	6520	63
1215	1846	1340	1230	1090f8	70	145	20	30	52	6	1070	6820	70
1220	2010	1450	1340	1200f8	75	150	25	30	52	6	1130	8000	77

Size	Low Speed Shaft							High Speed Shaft					
	D	b	h	t	S	L2	L	d1	b1	h1	t1	L1	
1100	120m6	32	18	11	M30	52	180	40h6	12	8	5	60	
1110	130m6	32	18	11	M30	52	200	50h6	14	9	5.5	75	
1120	150m6	36	20	12	M30	52	210	60h6	18	11	7	90	
1130	160m6	40	22	13	M36	62	240	60h6	18	11	7	90	
1140	180m6	45	25	15	M36	62	250	60h6	18	11	7	90	
1150	200m6	45	25	15	M36	62	280	60h6	18	11	7	90	
1160	220m6	50	28	17	M36	62	300	65h6	18	11	7	105	
1170	240m6	56	32	20	M36	62	360	70h6	20	12	7.5	120	
1180	260m6	56	32	20	M36	62	390	70h6	20	12	7.5	120	
1185	260m6	56	32	20	M36	62	390	70h6	20	12	7.5	120	
1190	280m6	63	32	20	M36	62	450	75h6	20	12	7.5	140	
1195	280m6	63	32	20	M36	62	450	95h6	25	14	9	150	
1200	320m6	70	36	22	M42	73	510	95h6	25	14	9	150	
1205	320m6	70	36	22	M42	73	510	95h6	25	14	9	150	
1210	360m6	80	40	25	M42	73	570	120h6	32	18	11	170	
1215	360m6	80	40	25	M42	73	570	120h6	32	18	11	170	
1220	400m6	90	45	28	M48	80	630	130h6	32	18	11	190	

- Appearance may be different from above drawing by size.
- Key is in compliance with parallel key of JIS B1301-1996(ISO).
- Above dimensions and specifications may change without notice.

Nomenclature

Size High Speed Shaft Low Speed Shaft Nominal Reduction Ratio

DHF - [] - [] [] - [71]

Blank...Inline
Blank...Solid Shaft Key

1100	1110	1120
1130	1140	1150
1160	1170	1180
1185	1190	1195
1200	1205	1210
1215	1220	

Size	Nominal Reduction Ratio										
	71	80	90	100	112	125	140	160	180	200	224
1110~1160	○	○	○	○	○	○	○	○	○	○	
1170		○	○	○	○	○	○	○	○	○	
1180		○	○	○	○	○	○	○	○	○	○
1185			○	○	○	○	○	○	○	○	
1190		○	○	○	○	○	○	○	○	○	○
1195		○	○	○	○	○	○	○	○	○	
1200			○	○	○	○	○	○	○	○	
1205				○	○	○	○	○	○	○	
1210				○	○	○	○	○	○	○	○
1215				○	○	○	○	○	○	○	○
1220				○	○	○	○	○	○	○	○

Dimension Table

DHF TYPE (Horizontal Flange, Inline)	Nominal Reduction Ratio	315~1400
--------------------------------------	-------------------------	----------

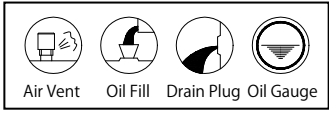
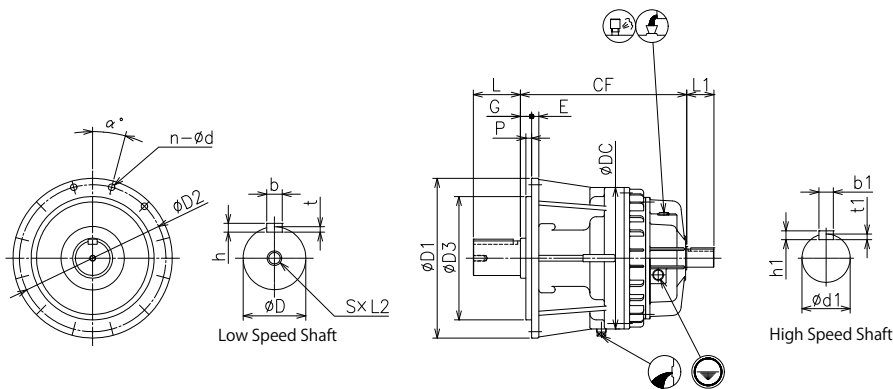

Unit : mm

Size	CF	D1	D2	D3	E	G	P	n	d	a	DC	Mass kg	Oil Qty ℓ
1010	304	200	175	130h7	12	10	5	6	12	30	166	26	0.4
1020	315	220	195	150h7	12	10	5	6	12	30	166	28	0.5
1030	341	245	215	170h7	16	10	5	6	14	30	200	39	0.7
1040	359	275	245	200h7	16	10	5	6	14	30	230	50	0.9
1050	401	315	285	240h7	16	10	5	6	14	30	280	74	1.4
1060	446	390	355	290h7	20	11	6	6	18	30	335	121	2.7
1070	482	440	405	340h7	20	11	6	8	18	22.5	390	179	4.9
1080	559	505	460	390h7	25	13	8	8	22	22.5	430	268	6.8
1090	574	545	500	430h7	25	13	8	8	22	22.5	470	292	8.0

Size	Low Speed Shaft							High Speed Shaft				
	D	b	h	t	S	L2	L	d1	b1	h1	t1	L1
1010	40h6	12	8	5	M10	20	55	25h6	8	7	4	35
1020	45h6	14	9	5.5	M12	25	65	25h6	8	7	4	35
1030	50h6	14	9	5.5	M12	25	70	25h6	8	7	4	35
1040	60h6	18	11	7	M12	25	85	25h6	8	7	4	35
1050	70h6	20	12	7.5	M12	25	100	25h6	8	7	4	35
1060	85h6	22	14	9	M16	30	120	25h6	8	7	4	35
1070	95h6	25	14	9	M16	30	130	25h6	8	7	4	35
1080	105h6	28	16	10	M16	30	145	30h6	8	7	4	45
1090	115h6	32	18	11	M16	30	160	30h6	8	7	4	45

- Appearance may be different from above drawing by size.
- Key is in compliance with parallel key of JIS B1301-1996(ISO).
- Above dimensions and specifications may change without notice.

Nomenclature

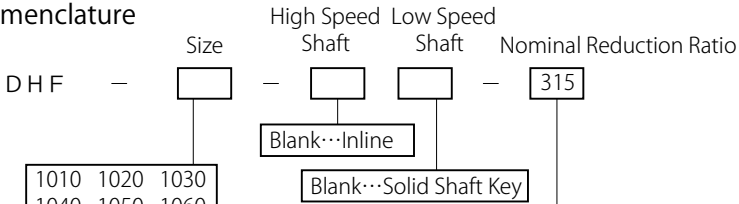

1010	1020	1030
1040	1050	1060
1070	1080	1090

Size	Nominal Reduction Ratio												
	315	355	400	450	500	560	630	710	900	1000	1120	1250	1400
1010~1070	○		○			○			○		○		○
1080・1090	○	○	○	○	○	○	○	○	○	○	○	○	○



Dimension Table

DHF TYPE (Horizontal Flange, Inline)	Nominal Reduction Ratio	250~1120
--------------------------------------	-------------------------	----------

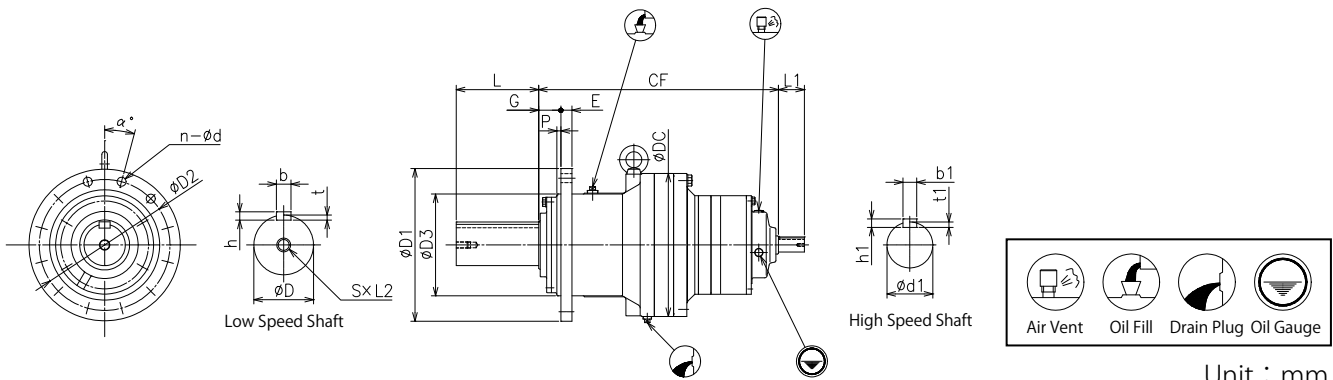

Unit : mm

Size	Nominal Reduction Ratio	CF	D1	D2	D3	E	G	P	n	d	a	DC	Mass kg	Oil Qty ℓ
1100	250~450	710	440	380	320f8	35	70	12	12	26	15	405	330	10.5
	500~1120	690	440	380	320f8	35	70	12	12	26	15	405	330	10.5
1110	250~280	761	540	480	420f8	35	75	15	12	26	15	410	435	11
	315~1120	744	540	480	420f8	35	75	15	12	26	15	410	435	11
1120	250 · 280	850	570	510	450f8	40	80	15	16	26	11.25	460	580	12.5
	315~1120	835	570	510	450f8	40	80	15	16	26	11.25	460	580	12.5
1130	250~400	901	625	555	485f8	40	90	15	16	33	11.25	510	690	15.5
	450~1120	886	625	555	485f8	40	90	15	16	33	11.25	510	690	15.5
1140	—	984	675	605	535f8	45	100	15	20	33	9	560	850	16
1150	—	1088	760	670	580f8	45	110	20	16	39	11.25	600	1100	17
1160	—	1230	810	720	630f8	50	120	20	20	39	9	650	1350	20.5
1170	—	1262	870	780	680f8	55	120	20	24	39	7.5	680	1700	24
1180	—	1321	930	840	730f8	55	120	20	24	39	7.5	730	2450	26
1185	—	1344	1000	910	800f8	55	120	20	30	39	6	805	2720	31

Size	Nominal Reduction Ratio	Low Speed Shaft							High Speed Shaft				
		D	b	h	t	S	L2	L	d1	b1	h1	t1	L1
1100	250~450	120m6	32	18	11	M30	52	180	35h6	10	8	5	50
	500~1120	120m6	32	18	11	M30	52	180	30h6	8	7	4	45
1110	250~280	130m6	32	18	11	M30	52	200	40h6	12	8	5	60
	315~1120	130m6	32	18	11	M30	52	200	35h6	10	8	5	50
1120	250 · 280	150m6	36	20	12	M30	52	210	50h6	14	9	5.5	75
	315~1120	150m6	36	20	12	M30	52	210	40h6	12	8	5	60
1130	250~400	160m6	40	22	13	M36	62	240	50h6	14	9	5.5	75
	450~1120	160m6	40	22	13	M36	62	240	40h6	12	8	5	60
1140	-	180m6	45	25	15	M36	62	250	40h6	12	8	5	60
1150	-	200m6	45	25	15	M36	62	280	50h6	14	9	5.5	75
1160	-	220m6	50	28	17	M36	62	300	60h6	18	11	7	90
1170	-	240m6	56	32	20	M36	62	360	60h6	18	11	7	90
1180	-	260m6	56	32	20	M36	62	390	60h6	18	11	7	90
1185	-	260m6	56	32	20	M36	62	390	60h6	18	11	7	90

Nomenclature

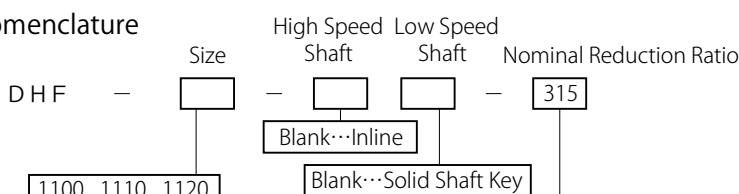

- Appearance may be different from above drawing by size.
- Key is in compliance with parallel key of JIS B1301-1996(ISO).
- Above dimensions and specifications may change without notice.

1100	1110	1120
1130	1140	1150
1160	1170	1180
1185		

Size	Nominal Reduction Ratio													
	250	280	315	355	400	450	500	560	630	710	800	900	1000	1120
1100~1130	○	○	○	○	○	○	○	○	○	○	○	○	○	○
1140					○	○	○	○	○	○	○	○	○	
1150~1170				○	○	○	○	○	○	○	○	○	○	
1180					○	○	○	○	○	○	○	○	○	
1185						○	○	○	○	○	○	○	○	

Dimension Table

DHF TYPE (Horizontal Flange, Inline)	Nominal Reduction Ratio	355~1120
--------------------------------------	-------------------------	----------

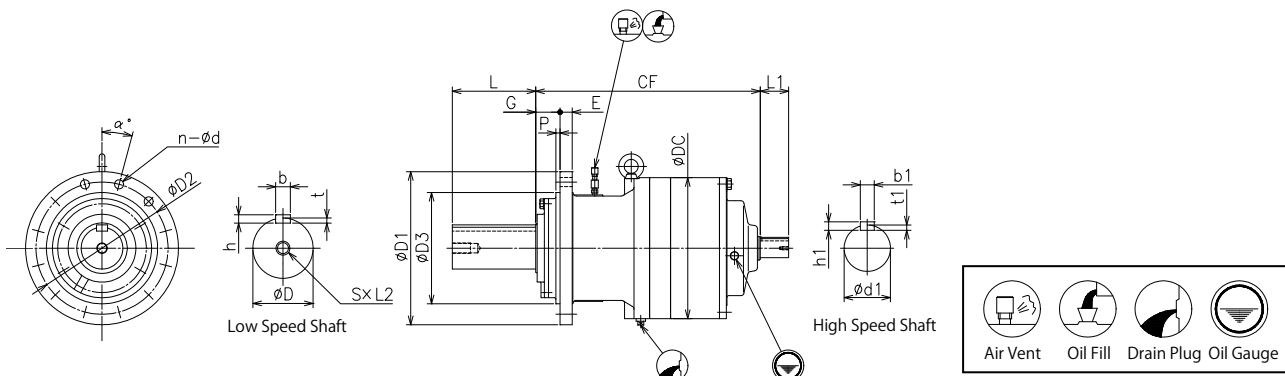

Unit : mm

Size	CF	D1	D2	D3	E	G	P	n	d	a	DC	Mass kg	Oil Qty ℓ
1190	1526	1050	950	830f8	60	125	20	24	45	7.5	835	3130	36
1195	1567	1100	1000	880f8	60	125	20	30	45	6	890	3450	43
1200	1685	1180	1070	940f8	65	130	20	24	52	7.5	940	4700	47
1205	1717	1220	1110	980f8	65	130	20	24	52	7.5	980	5500	53
1210	1885	1300	1190	1050f8	70	145	20	24	52	7.5	1030	6320	57
1215	1937	1340	1230	1090f8	70	145	20	30	52	6	1070	6700	66
1220	2099	1450	1340	1200f8	75	150	25	30	52	6	1130	7800	70

Size	Low Speed Shaft							High Speed Shaft				
	D	b	h	t	S	L2	L	d1	b1	h1	t1	L1
1190	280m6	63	32	20	M36	62	450	60h6	18	11	7	90
1195	280m6	63	32	20	M36	62	450	60h6	18	11	7	90
1200	320m6	70	36	22	M42	73	510	65h6	18	11	7	105
1205	320m6	70	36	22	M42	73	510	65h6	18	11	7	105
1210	360m6	80	40	25	M42	73	570	70h6	20	12	7.5	120
1215	360m6	80	40	25	M42	73	570	70h6	20	12	7.5	120
1220	400m6	90	45	28	M48	80	630	75h6	20	12	7.5	140

- Appearance may be different from above drawing by size.
- Key is in compliance with parallel key of JIS B1301-1996(ISO).
- Above dimensions and specifications may change without notice.

Nomenclature

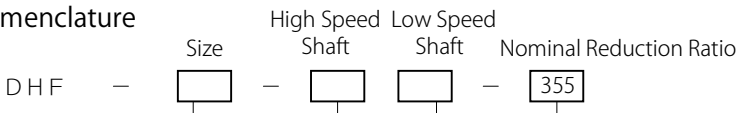

1190	1195
1200	1205
1210	1215
1220	

Size	Nominal Reduction Ratio										
	355	400	450	500	560	630	710	800	900	1000	1120
1190	○	○	○	○	○	○	○	○	○	○	○
1195		○	○	○	○	○	○	○	○	○	○
1200	○	○	○	○	○	○	○	○	○	○	○
1205		○	○	○	○	○	○	○	○	○	○
1210		○	○	○	○	○	○	○	○	○	○
1215		○	○	○	○	○	○	○	○	○	○
1220		○	○	○	○	○	○	○	○	○	○

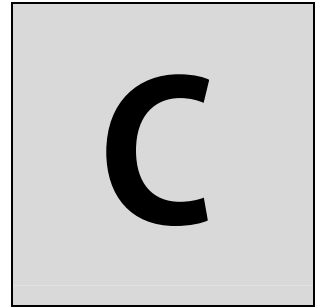

Technical Data

Lubrication and Installation.....	C-2
Painting Specifications and Rust Proof Standard	C-3
Moment of Inertia.....	C-4
Specifications/Dimensions for Spline shaft.....	C-6
Dimensions of Motor Adapter JEM / IEC	C-7
Warranty Policy	C-8
Safety Precautions	C-9
Inquiry / Order Specification Sheet form.....	C-10

■ Lubrication

1. Standard Lubrication Method

- Oil bath lubrication is applied to all models.
- Grease lubrication for some right angle input shaft.

2. Recommended Lubricants

	Ambient Temperature	ISO AGMA	BP	CASTROL			CHEVRON TEXACO		EXXON MOBIL		SHELL	TOTAL
Gear Oil	-10 deg to +25 deg	VG150 4EP	ENERGOL GR-XP-150	ALPHA SP150	OPTIGEAR BM150	TRIBOL 1100/150	GEAR COMPOUNDS EP150	MEROPA WM150	SPARTAN EP150	MOBIL-GEAR 629	OMALA 150	CARTER EP150
	+10 deg to +40 deg	VG220 5EP	ENERGOL GR-XP-220	ALPHA SP220	OPTIGEAR BM220	TRIBOL 1100/220	GEAR COMPOUNDS EP220	MEROPA WM220	SPARTAN EP220	MOBIL-GEAR 630	OMALA 220	CARTER EP220
	+30 deg to +50 deg	VG320 6EP	ENERGOL GR-XP-320	ALPHA SP320	OPTIGEAR BM320	TRIBOL 1100/320	GEAR COMPOUNDS EP320	MEROPA WM320	SPARTAN EP320	MOBIL-GEAR 632	OMALA 320	CARTER EP320
Bearing grease			ENER-GREASE LS EP2	SPHEEROL AP3	Olista Long-time 3EP	TRIBOL 3020/1000-2	DURALITH GREASE 68	MULTI-FAK EP2	BEACON EP2	MOBIL-PLEX 48	ALVANIA EP2	MULTIS EP2

- The grease lubrication part is filled up with grease when shipping and you may use as it is.

3. Time of replenishment and replacement.

- Lubricant has been evacuated on shipment. Be sure to replenish lubricant up to the standard level of oil gauge. It is recommended to replace lubricant after 500 hours operation for the first time and in every 2500 hours or every half year, whichever comes first, after then.

4. Consult us when the ambient temperature is lower than -10°C or higher than +40°C, when the standard input speed will be over 1800r/min or when irregular operating condition will be required.

■ Installation

- (1) Consult us when the product is to be installed on an inclined surface or on a ceiling. Additional lubrication system may be necessary.
- (2) Install the product horizontally on a sufficiently rigid base. When the product is made for inclined installation according to your specification, do not install it at any other angle than the specified angle.
- (3) Installation bolts for the reducer shall be equivalent to JIS(ISO) strength classification 10.9. Consult us when the force that pushes up reducer is to be applied.
- (4) Refer to the maintenance manual attached to the product for other remarks regarding to installation and maintenance.

■ Painting Specifications

Surface Condition	Kind of Painting		Days	Painting Specification			Application
	Class	Painting of Finish Coat		Type	Coating (Thickness:μm)	Type of Coating	
Cast Iron Class 1 Steel Plate Class 2	Standard painting	—	0	Under	1 (20~40)	Modified epoxy resin	Standard under coat
		Phallic acid		Finish	1 (15~30)	Alkyd resin paint	Standard finish coat
	Standard export painting	—	2	Under	2 (40~80)	Modified epoxy resin	Export standard
		Modified epoxy		Finish	1 (15~30)	Vinyl modified epoxy resin	
	Special painting (Including rust-proof and heat resisting painting) One layer of Modified epoxy resin Primer as the first prime	Modified epoxy	3	Under	1 (20~40)	Vinyl modified epoxy resin	Moderate corrosive atmosphere, seaside, outdoor humid atmosphere, etc.
				Finish	2 (30~60)	Vinyl modified epoxy resin	
		Long of oil phallic	7	Under	2 (40~70)	Lead rust preventive paint	Ocean-going vessels, bridge, seaside, outdoor humid atmosphere, etc.
				Finish	2 (30~60)	Synthetics resin paint	
		Chloride rubber	10	Under	2 (40~70)	Lead rust preventive paint	Ocean-going vessels, bridge, seaside, outdoor humid atmosphere, etc.
				Second	1 (20~40)	Phenol M.I.O. paint	
		Phenol	7	Under	2 (40~70)	Lead rust preventive paint	In-and-outdoor of acid treating plant and chemical plant, etc.
				Finish	2 (30~60)	Phenol resin enamel	
	Heat-proof silver	7	Under	1 (20~40)	Lead rust preventive paint	Heating furnace(120°C), etc.	
			Finish	1 (15~30)	Aluminum paint		
	Extra rust-proof painting	Epoxy	10	Under	1 (50~60)	Special permeability epoxy aluminum paint	Nuclear power generation
Finish				3 (120~240)	Polyamide epoxy		
Polyurethane		10	Under	1 (50~60)	Special permeability epoxy aluminum paint	Nuclear power generation	
			Finish	3 (45~90)	Polyisocyanate urethane resin paint		
Extra rust-proof painting(Sand blast under coating)	Thick film epoxy	12		5 (250~350)	Thick film type modified epoxy resin paint	Submersible equipment, marine structure, etc.	

Note: 1. Days mean extra days necessary for Special Painting in comparison with Standard Painting.

2. Our standard color is Donau Blue (equivalent Munsell color: 6.5PB 3.6 / 8.2).

■ Rust Proof Standard

Rust proofing treatment has been conducted on all completely assembled models prior to shipment.

1. Standard rust proofing specifications

(1) Outside rust proofing specifications

Rust proofing oil has been applied to products before shipment. Check the rust proofing conditions every 6 months after shipment, and conduct rust proofing treatment, if necessary.

(2) Inside rust proofing specifications

Rust proofing period	6 months
Storage condition	Generally to be stored inside the warehouse, relatively free of humidity, dust, extreme temperature fluctuation, corrosive gas, and similar atmosphere. After shipment, the product shall be operated 5-10 minutes every 2-3 months with our recommended lubricants.

2. Export rust proofing specifications

Consult us for export rust proofing when export specifications or severe specifications are required.

■ Moment of Inertia

Reducer Moment of Inertia [kg · m²]

Nominal Reduction Ratio	Size of Reducer											
	1010	1020	1030	1040	1050	1060	1070	1080	1090	1100	1110	1120
5	0.00028	0.00033	0.00075	0.00153	0.00390	0.01040	0.02110					
9	0.00018	0.00018	0.00045	0.00098	0.00223	0.00643	0.01270					
16	0.00042	0.00043	0.00107	0.00111	0.00308	0.00713	0.01951	0.03635	0.03785			
18				0.00111	0.00211	0.00536	0.01900	0.03141	0.03141			
20				0.00100	0.00198	0.00491	0.01900	0.02827	0.02827	0.01855	0.03188	0.05516
22.4	0.00025	0.00025	0.00066	0.00068	0.00185	0.00408	0.01143	0.02202	0.02290	0.01544	0.02653	0.04591
25						0.00407	0.00950	0.02110	0.02261	0.01538	0.02642	0.04571
28						0.00370	0.00841	0.01970	0.02019	0.01398	0.02402	0.04155
31.5	0.00019	0.00019	0.00047	0.00048	0.00128	0.00275	0.00799	0.01543	0.01585	0.01039	0.01785	0.03088
35.5				0.00046	0.00127	0.00263	0.00755	0.01444	0.01592	0.00995	0.01709	0.02957
40	0.00016	0.00016	0.00041	0.00041	0.00106	0.00223	0.00663	0.01281	0.01285	0.00845	0.01452	0.02512
45						0.00248	0.00663	0.01256	0.01256	0.00937	0.01611	0.02787
50	0.00043	0.00043	0.00046	0.00046	0.00121	0.00328	0.00771	0.02061	0.02075			
56					0.00121	0.00328	0.00771	0.01997	0.02001			
63					0.00118	0.00320	0.00773	0.01255	0.01985			
71	0.00042	0.00042	0.00044	0.00044	0.00113	0.00309	0.00348	0.00781	0.01964	0.00715	0.01957	0.03646
80					0.00088	0.00153	0.00300	0.00707	0.00707	0.00538	0.01905	0.03150
90	0.00025	0.00025	0.00026	0.00026	0.00069	0.00184	0.00208	0.00447	0.00452	0.00492	0.01905	0.02835
100					0.00077	0.00127	0.00211	0.00423	0.00430	0.00409	0.01147	0.02209
112					0.00072	0.00115	0.00197	0.00420	0.00419	0.00408	0.00950	0.02268
125	0.00025	0.00025	0.00025	0.00025	0.00066	0.00070	0.00189	0.00410	0.00412	0.00371	0.00839	0.02025
140					0.00063	0.00065	0.00165	0.00404	0.00404	0.00275	0.00801	0.01548
160					0.00058	0.00060	0.00145	0.00353	0.00353	0.00304	0.00757	0.01597
180	0.00018	0.00018	0.00019	0.00019	0.00048	0.00050	0.00126	0.00270	0.00271	0.00224	0.00665	0.01285
200					0.00045	0.00047	0.00110	0.00240	0.00270		0.00665	0.01260
224	0.00016	0.00016	0.00016	0.00016	0.00041	0.00042	0.00103	0.00220	0.00221			
250										0.00328	0.00771	0.02061
280										0.00328	0.00771	0.01997
315	0.00043	0.00025	0.00043	0.00043	0.00043	0.00047	0.00059	0.00139	0.00140	0.00309	0.00773	0.01255
355								0.00139	0.00140	0.00178	0.00348	0.00781
400	0.00042	0.00042	0.00042	0.00042	0.00042	0.00044	0.00051	0.00128	0.00128	0.00153	0.00300	0.00707
450								0.00126	0.00126	0.00184	0.00208	0.00447
500								0.00113	0.00113	0.00115	0.00197	0.00505
560	0.00025	0.00025	0.00025	0.00025	0.00025	0.00026	0.00031	0.00077	0.00077	0.00070	0.00189	0.00410
630								0.00080	0.00080	0.00070	0.00172	0.00410
710								0.00080	0.00080	0.00065	0.00165	0.00404
800	0.00025	0.00025	0.00025	0.00025	0.00025	0.00025	0.00027	0.00070	0.00070	0.00060	0.00145	0.00353
900								0.00063	0.00063	0.00050	0.00126	0.00270
1000								0.00057	0.00057	0.00047	0.00110	0.00283
1120	0.00018	0.00018	0.00018	0.00018	0.00018	0.00019	0.00020	0.00050	0.00050	0.00042	0.00103	0.00220
1250								0.00045	0.00045			
1400	0.00016	0.00016	0.00016	0.00016	0.00016	0.00016	0.00017	0.00042	0.00042			

Note: 1. Above figures are for high speed shaft.



Size of Reducer													
1130	1140	1150	1160	1170	1180	1185	1190	1195	1200	1205	1210	1215	1220
0.08212	0.14927												
0.06834	0.12422												
0.06805	0.12370												
0.06186	0.11244												
0.04598	0.08357												
0.04402	0.08002												
0.03740	0.06798												
0.04149	0.07542												
0.03796	0.05113	0.08105	0.13407										
0.03150	0.03845	0.06095	0.10081	0.14266	0.19030		0.36994	0.49312					1.97224
0.02835	0.03518	0.05577	0.09226	0.13055	0.17415	0.19152	0.33854	0.46111	0.64555		1.09652	1.43211	1.80483
0.02297	0.02928	0.04642	0.07678	0.10865	0.14493	0.17681	0.28174	0.40388	0.53724	0.65930	0.91255	1.29388	1.50206
0.02268	0.02916	0.04622	0.07646	0.10819	0.14432	0.14615	0.28056	0.39983	0.53498	0.58391	0.90872	1.00514	1.49571
0.02025	0.02650	0.04201	0.06950	0.09834	0.13119	0.14595	0.25503	0.35535	0.48630	0.58105	0.82602	0.89313	1.35960
0.01590	0.01970	0.03123	0.05165	0.07309	0.09750	0.10122	0.18954	0.29087	0.36143	0.52933	0.61393	0.71544	1.01050
0.01597	0.02170	0.03441	0.05691	0.08053	0.10743	0.11218	0.20884	0.30054	0.39822	0.39987	0.67642	0.78985	1.11336
0.01285	0.01602	0.02540	0.04201	0.05945	0.07931	0.08210	0.15417	0.24993	0.29399	0.43104	0.49936	0.56374	0.82193
0.01260	0.01778	0.02818	0.04661	0.06596	0.08799	0.09113	0.17104		0.32616	0.34980	0.55401	0.59981	0.91187
					0.07188		0.13973				0.45258	0.50733	0.74493
0.02075													
0.02001													
0.01985													
0.01964		0.01957	0.03646	0.03646					0.13487				
0.00707	0.00715	0.01905	0.03150	0.03150	0.03796		0.06397	0.06532	0.11653	0.13987	0.19065	0.19387	0.30292
0.00452	0.00538	0.01905	0.02835	0.02835	0.03150	0.03927	0.05308	0.05487	0.09669	0.11844	0.15819	0.16006	0.25135
0.00505	0.00492	0.01147	0.02209	0.02209	0.02835	0.03211	0.04777	0.04899	0.08702	0.10008	0.14237	0.14473	0.22621
0.00412	0.00409	0.00950	0.02268	0.02268	0.02297	0.02451	0.03870	0.04001	0.07050	0.08946	0.11535	0.11815	0.18328
0.00412	0.00408	0.00839	0.02025	0.02025	0.02266	0.02409	0.03822	0.03599	0.06962	0.07316	0.11390	0.11667	0.18097
0.00404	0.00371	0.00801	0.01548	0.01548	0.02025	0.02222	0.03412	0.02734	0.06216	0.06418	0.10169	0.10234	0.16158
0.00353	0.00275	0.00757	0.01597	0.01597	0.01590	0.01631	0.02679	0.02755	0.04880	0.04997	0.07984	0.08511	0.12685
0.00271	0.00304	0.00665	0.01285	0.01285	0.01597	0.01650	0.02691		0.04903		0.08021	0.08703	0.12744
0.00283	0.00224	0.00665	0.01260	0.01260	0.01285	0.01343	0.02165	0.02238	0.03945	0.05081	0.06453	0.06686	0.10254
0.00221	0.00249				0.01260		0.02123	0.02204		0.04077	0.06328		0.10054

■ Specifications/Dimensions for Spline Shaft

In case spline shaft is used for slow speed shaft, dimensions are as follows.

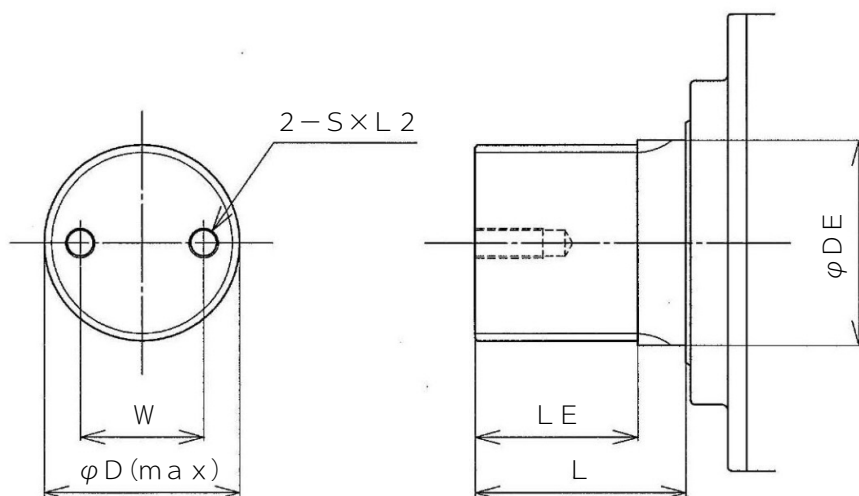

(Unit : mm)

Size	Spline spec.	$\phi D(\max)$	ϕDE	L	LE	W	S	L2
1100	120×22×5	119	-	100	100	63	M16	32
1110	130×24×5	129	-	110	110	80	M20	45
1120	150×18×7.5	148.5	-	120	120	80	M20	45
1130	160×19×7.5	158.5	-	130	130	100	M24	51
1140	180×22×7.5	178.5	-	150	150	100	M24	51
1150	200×25×7.5	198.5	200p6	220	160	125	M30	64
1160	220×20×10	218	220p6	250	170	125	M30	64
1170	240×22×10	238	240p6	260	180	125	M30	64
1180	260×24×10	258	260p6	260	180	160	M36	70
1185	260×24×10	258	260p6	260	180	160	M36	70
1190	280×26×10	278	280p6	300	220	160	M36	70
1195	280×26×10	278	280p6	300	220	160	M36	70
1200	320×30×10	318	320r6	320	240	200	M36	70
1205	320×30×10	318	320r6	320	240	200	M36	70
1210	360×34×10	358	360r6	330	250	200	M36	70
1215	360×34×10	358	360r6	330	250	200	M36	70
1220	400×38×10	398	400r6	340	260	250	M36	70

Gear standard : In conformity with JIS B1603-1995 attachment "Involute Spline (standard pressure angle 20°)".
(Same as old standard JIS D2001-1959 "Involute Spline for automobiles".)

Dimensions of Motor Adapter JEM/IEC

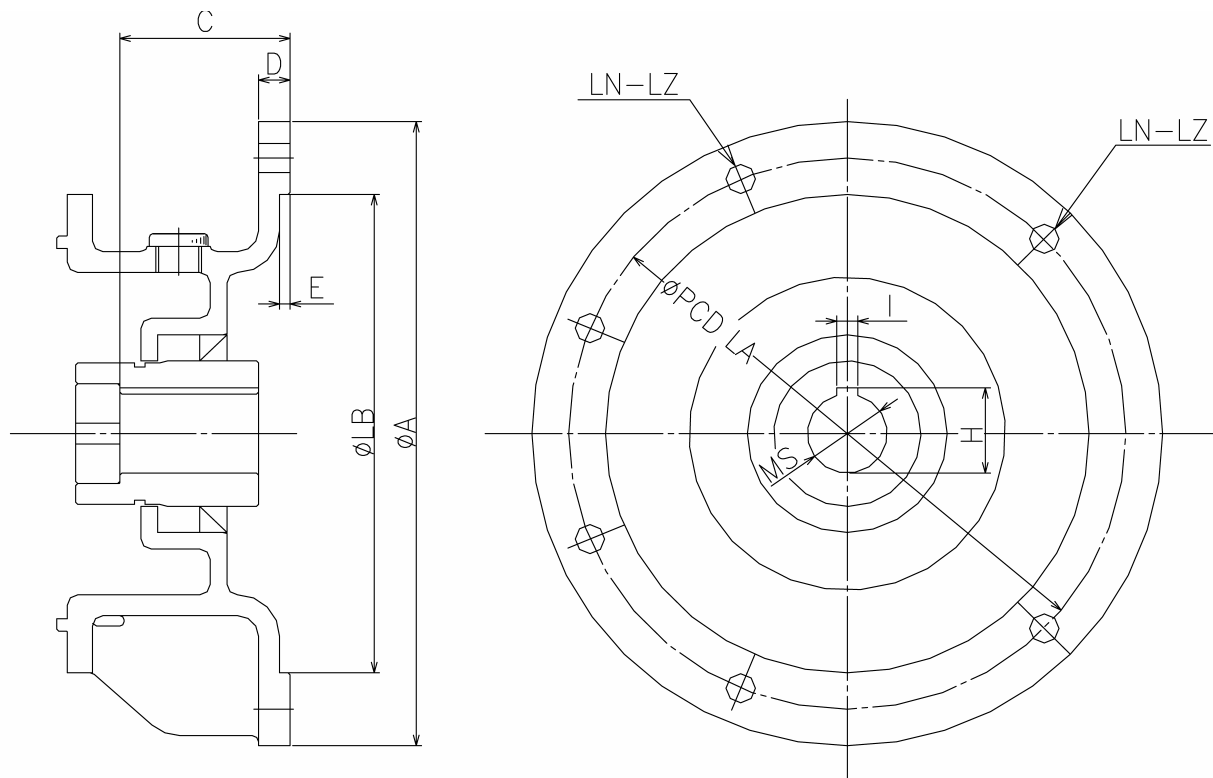

Unit : mm

Motor Capacity code	JEM (Standard)		IEC		A	LB	C	D	E	φMS	H	I	LA	LN	LZ
	kW×pole	Frame size	kW×pole	Frame size											
02	0.2×4P	63	-	63	160	110	23	13	4.5	11	-	-	130	4	10
05	0.4×4P	71	0.25×4P,0.37×4P	71	160	110	30	13	4.5	14	16.3	5	130	4	10
1	0.75×4P	80	0.55×4P,0.75×4P	80	200	130	40	13	4.5	19	21.8	6	165	4	12
2	1.5×4P	90L	1.1×4P,1.5×4P,1.85×4P	90L	200	130	50	13	4.5	24	27.3	8	165	4	12
3	2.2×4P	100L	2.2×4P,3×4P	100L	250	180	60	13	5	28	31.3	8	215	4	15
5	3.7×4P	112M	4×4P	112M	250	180	60	13	5	28	31.3	8	215	4	15
8	5.5×4P	132S	5.5×4P	132S	300	230	80	15	5	38	41.3	10	265	4	15
10	7.5×4P	132M	7.5×4P	132M	300	230	80	15	5	38	41.3	10	265	4	15
15	11×4P	160M	11×4P	160M	350	250	110	18	6	42	45.3	12	300	4	19
20	15×4P	160L	15×4P	160L	350	250	110	18	6	42	45.3	12	300	4	19
25	18.5×4P	180M	-	-	400	300	110	18	6	48	51.8	14	350	4	19
-	-	-	18.5×4P	180M*	350	250	110	18	6	42	45.3	12	300	4	19
30	22×4P	180M	-	-	400	300	110	18	6	48	51.8	14	350	4	19
-	-	-	22×4P	180L*	350	250	110	18	6	42	45.3	12	300	4	19
40	30×4P	180L	30×4P	200L	400	300	110	18	6	55	59.3	16	350	4	19
50,60	37×4P,45×4P	200L	37×4P,45×4P	225S	450	350	140	22	6	60	64.4	18	400	8	19
75	55×4P	225S	55×4P	250M	550	450	140	22	6	65	69.4	18	500	8	19

Note 1. Motor adapters with other dimensions than as listed in this table can be also manufactured. Please send us your inquiry.

Note 2. Special adapter may be necessary for these flanges with * mark. Please consult us when you need them.



Guarantee standard

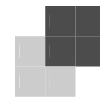

Warranty Period	The warranty period for the Products shall be 18 months after the commencement of delivery or 18 months after the shipment of the Products from the seller's works or 12 months from the Products coming into operation, whichever comes first.
Warranty Condition	<p>In Case that any problems, troubles or damages on the Products arise due to the defects in the Products during the above "Warranty Period" , although the Products are appropriately and properly installed in, connected or combined to the equipment or machines, or maintained in accordance with the maintenance manual and are properly operated under the conditions as described in the catalogue or otherwise as agreed upon in writing between the Seller and the Buyer or its customers, the Seller will provide, at its sole discretion, appropriate repair or replacement on the Products free of charge, except as stipulated in the "Exception for Warranty" as described below.</p> <p>However, in the event that the Products is installed in, connected or combined to or integrated into the equipment or machines, the Seller shall not reimburse the costs for removal or re-installation of the Products or other incidental costs related thereto and any lost opportunity, loss of profit or any other incidental or consequential losses or damages incurred by the Buyer or its customers.</p>
Exception for Warranty	<p>Notwithstanding the above warranty, the warranty as set forth herein shall not be applied to the problems, troubles or damages on the Products which are caused by:</p> <ol style="list-style-type: none"> 1. installations, connections, combinations or integration of the Products in or to the other equipment or machines, which are rendered by any person or entity other than the Seller, 2. the insufficient maintenance or improper operation by the Buyer or its customers, such that the Product is not appropriately maintained in accordance with the maintenance manual provided or designated by the Seller, 3. the improper use or operation of the Products by the Buyer or its customers which are not informed to the Seller, including, without limitation, the Buyer's or its customers' operation of the Products not in conformity with the specifications, or use of the lubrication oil in the Products which is not recommended by the Seller, 4. troubles, problems or damages on any equipment or machines in or to which the Products are installed, connected or combined or installed, or any specifications particular to the Buyer or its customers.



SAFETY PRECAUTIONS

General

1. Strictly observe the safety rules for the installation place and the equipment to use. (Industrial Safety and Health Law, Technical Standard for Electric Facilities, Extension Rules, Plant Explosion Guidelines, Building Standards Law, etc.)
2. Carefully read the maintenance manual before use. The maintenance manual should be sent to the actual user.
3. Strictly confirm the power source has been off before installation or removal of the product.
4. Install a protective cover on the coupling joint.

Selection

1. Select an appropriate product that matches the operating environment and usage.
 2. Consult us when the machine is used for transportation of passengers. Install a protective equipment on the machine side for safety sake.
 3. Use the explosion-proof type motor when the using condition may be explosive.
 4. When the machine is used for food processing and others that are susceptible to oil, install an oil pan or other damage preventive devices in case of oil leakage.
-

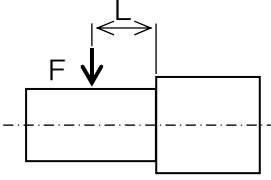

Data sheet for order and inquiry

1. Application	11. Connection between motor and driven machine High speed shaft <input type="checkbox"/> Coupling <input type="checkbox"/> Chain/V belt <input type="checkbox"/> Other (_____) External Radial Load F= _____ N L= _____ mm Low speed shaft <input type="checkbox"/> Coupling <input type="checkbox"/> Gear <input type="checkbox"/> Other (_____) External Radial Load F= _____ N L= _____ mm 
2. Quantity	
3. Delivery date	
4. Delivery place	
5. Nomenclature <input type="checkbox"/> Foot Mount <input type="checkbox"/> Flange Mount <input type="checkbox"/> Horizontal <input type="checkbox"/> Vertical <input type="checkbox"/> Inline <input type="checkbox"/> Motor Direct Mount <input type="checkbox"/> Right Angle	
6. Prime mover <input type="checkbox"/> Electric motor <input type="checkbox"/> Engine <input type="checkbox"/> Hydraulic motor	
7. Reduction Ratio $i =$ _____	
8. Using Conditions Input Speed _____ r/min Normal torque of Low speed shaft _____ N·m Max. torque of Low speed shaft _____ N·m Transmission power _____ kW Operating hours _____ hours/day Operating duty _____ %/hour Direction of Rotation <input type="checkbox"/> One way <input type="checkbox"/> Bidirectional	
9. Service Factor	
10. Bearing Life	
Remarks	12. Ambient conditions Location <input type="checkbox"/> Indoor-closed <input type="checkbox"/> Indoor-open <input type="checkbox"/> Outdoor Ambient temperature MIN _____ °C MAX _____ °C Dust <input type="checkbox"/> Much <input type="checkbox"/> Less Wind _____ m/sec

