

# TRANSDRIVE®

## DRIVE PERFORMANCE



## Couplings

[transdrive.com.au](http://transdrive.com.au)

# TRANSDRIVE<sup>®</sup>

## DRIVE PERFORMANCE

TransDrive was established to bring together our passion and experience in power transmission by being able to offer affordable, high-quality products to the power transmission and bearing market. Built on the philosophy of improving performance and quality of all of our TransDrive products.

Transdrive products have been manufactured and tested to meet ISO standards and the tough, working conditions of heavy industries.

Our team have experience in power transmission and bearings. Every product we design and manufacture is backed by years of industry knowledge and an understanding of what our customers and the market need.

At TransDrive, our goal is simple: to provide accessible, high-quality products at affordable pricing. With an unwavering commitment to excellence, TransDrive operates with a focus on providing innovative industry solutions.

Whether it is through our custom products, the standard range of pulleys, slew drives, chains and sprockets, TransDrive is dedicated to delivering effective solutions for the trades that offer increased productivity and reliability.

TransDrive exclusively supply to Resellers, Wholesalers, and Original Equipment Manufacturers (OEMs) only.

## Distributors

### Western Australia

#### Chain & Drives, Wangara

Unit 1, 45 Inspiration Drive,  
Wangara, WA 6065 Australia

**P** +61 8 9303 4966

**E** [support@chainanddrives.com.au](mailto:support@chainanddrives.com.au)

#### Chain & Drives, Welshpool

Unit 16, 51-53 Kewdale Road,  
Welshpool, WA 6106 Australia

**P** +61 8 6314 1155

**E** [support@chainanddrives.com.au](mailto:support@chainanddrives.com.au)

### New South Wales

#### Chain & Drives, Arndell Park

Unit 7/70 Holbeche Road,  
Arndell Park, NSW 2148 Australia

**P** +61 2 9674 8611

**E** [salesnsw@chainanddrives.com.au](mailto:salesnsw@chainanddrives.com.au)

#### Tank Enviro Systems

Unit 6, 68 Railway Crescent,  
Lisarow, NSW 2250

**P** +61 2 4328 1066

**E** [tankadmin@tankenviro.com.au](mailto:tankadmin@tankenviro.com.au)

## Become a TransDrive Dealer

### Interested in becoming a TransDrive Dealer?

Get in touch:

**E** [info@transdrive.com.au](mailto:info@transdrive.com.au)

# Contents

<b>Introduction</b>	<b>4</b>
About Shaft Couplings	4
<b>Flexible &amp; Elastomeric Couplings</b>	<b>5</b>
Cone Ring Couplings	6
Curved Jaw Couplings	12
HRC Couplings	14
Jaw Flex L Series Wrap Couplings	17
NM Jaw Couplings	24
Spacer Couplings	25
Dynamic <sup>®</sup> Tyre Couplings	26
Tyre Couplings	32
<b>Mechanical Flexing Couplings</b>	<b>34</b>
Chain Couplings	35
Curved Tooth Gear Couplings	39
KCP Coupling Selection	40
KCP Gear Couplings	41
KCP Grid Couplings	48
<b>Rigid Couplings</b>	<b>58</b>
Clamp & Split Couplings	59
RM Rigid Couplings	61

Couplings are to be used to mechanically connect two shafts to transmit power from one shaft to another. They are also able to compensate for shaft misalignment in a torsionally rigid way.

Misalignment can be angular, parallel, axial (end-float) or skew. This is particularly important for applications where misalignment could affect the speed and acceleration of the driven shaft. The performance of the coupling depends on how it is installed and maintained.

There is a variation of couplings on the market today. Selecting the correct coupling for a particular application can be complicated.

Couplings may be classified as rigid, mechanically flexible, elastomeric flexible and fluid.

Depending on the type of the coupling may be required to tolerate a variety of conditions during its service life.

Some of these functions could be to:

- ▶ Transmit power (torque).
- ▶ Permit and accommodate limited amounts of misalignment.
- ▶ Allow for ease of assembly, maintenance and dis-assembly.
- ▶ Allow for some amount of dampening.
- ▶ Allow or compensate for end-float/axial movement/thermal expansion.
- ▶ Retain rigidity between the connecting hubs and the shafts.
- ▶ Withstand/compensate for temperature fluctuations/thermal growth.
- ▶ Provide protection against overload of the driven machine.

## Selection Procedure

<b>Service Factor</b>	Determine appropriate service factor from the Table below
<b>Design Power</b>	Multiply running power of driven machinery by the Service Factor. This gives Design Power which is used as a basis for coupling selection
<b>Coupling Size</b>	Refer to respective table for your required coupling type and read from the appropriate speed column until a power equal to or greater than the design power is found.
<b>Bore Size</b>	Refer respective coupling dimensional table to check that the required bores can be accommodated.

## Service Factors

Special Class <sub>1</sub>	Type of Driving Unit					
	Electric Motors / Steam Turbines			Internal Combustion Engines / Steam Engines / Water Turbines		
	Hours Per Day Duty			Hours Per Day Duty		
Driven Machine Class <sub>2</sub>	8 and under	Over 8 to 16 inclusive	Over 16	8 and under	Over 8 to 16 inclusive	Over 16
Uniform	1.00	1.12	1.25	1.25	1.40	1.60
Moderate Shock <sub>3</sub> *	1.60	1.80	2.00	2.00	2.24	2.50
Heavy Shock <sub>4</sub> **	2.50	2.80	3.12	3.12	3.55	4.00

\* It is recommended that top clearance keys are fitted for applications where load fluctuation is expected.

\*\* For Centrifugal Compressor multiply Service Factor by an additional 1.15.

1. For applications where substantial shock, vibration and torque fluctuation occur, and for reciprocating machines, e.g. internal combustion engines, piston type pumps and compressors, refer to Power Transmission with full machine details for torsional analysis.
2. Agitators, Brewing Machinery, Centrifugal Compressors\*\*, Conveyors, Centrifugal Fans and pumps, Generators, Sewage Disposal Equipment.
3. Clay working machinery, Crane Hoists, Laundry machinery, Wood working machinery, Machine Tools, Rotary Mills, Paper Mill machinery, Textile machinery.
4. Reciprocating conveyors, Crushers, Shakers, Metal Mills, Rubber machinery. (Banbury Mixers and Mills, Reciprocating Compressors.)

# Flexible & Elastomeric Couplings

Flexible couplings transmit torque between two shafts while accommodating for any misalignment, reducing vibration and noise, and providing a flexible or movable connection between the input and output shafts.

These couplings are commonly used in applications such as pumps, compressors, conveyors, and other machinery that requires a reliable and efficient method of transmitting torque while accommodating for misalignment.

When compared to metallic couplings, elastomeric couplings are easier to install and require less maintenance. They provide superior vibration and shock absorption, reducing wear, extending service life and provide greater protection to equipment due to their ability to accommodate larger misalignment angles.

## Our range

- ▶ Cone Ring Couplings
- ▶ Dynamic Couplings
- ▶ GE Curved Jaw Couplings
- ▶ HRC Couplings
- ▶ Jaw Couplings
- ▶ NM Jaw Coupling Element
- ▶ Spacer Couplings
- ▶ Tyre Couplings



TransDrive Cone Ring Couplings transmit the load from one member to the other by means of a number of steel pins fitted with multiple, conical section Flexirings.

The pin and rubber design ensures trouble-free maintenance, allowing for removal and replacement without the need to disassemble the coupling from the shafts.

### Features & Benefits

- ▶ Simple construction
- ▶ Requires no lubrication or maintenance
- ▶ Reduce starting shock
- ▶ Helps absorb vibration and provide torsional flexibility
- ▶ Operates in either direction
- ▶ Coupling halves manufactured from high-grade cast-iron. They can be supplied in cast-steel on application
- ▶ Each flexiring and pin assembly can be removed by withdrawing them through the bush half of the coupling for ease of replacement of the flexirings after long service



### Selection Procedure

- ▶ From the table below determine the Service Factor
- ▶ Calculate the Design Power by multiplying the Absorbed Power of the driven machine by the Service Factor
- ▶ Determine the size of coupling required by matching the design power to a power rating that matches or exceeds the Design Power.

Duty	Electric Motor
Uniform	1.0
Light	1.5
Moderate	2.0
Heavy	2.5
Severe	3.0

The Pin Half is normally mounted on the drive shaft.

### Service Factors

Bore	MC020	MC030	MC038	MC042	MC048	MC058	MC070	MC075	MC085	MC105	MC120	MC135	MC150
Power kW per 100rpm	0.55	1.16	1.87	2.84	4.93	7.54	10.70	25.70	35.50	53	90	122	160
Power kW per 720rpm	3.96	8.40	13.50	20.40	35.50	54.30	77	185	255	381	648	878	1152
Power kW per 960rpm	5.28	11.10	18	27.30	47.30	72.40	102	246	340	508	864	1171	1536
Power kW per 1440rpm	7.92	16.70	26.90	40.90	71	108	154	370	511	763	1026	1756	2304
Power kW per 2880rpm	15.84	33.40	53.90	81.80	142	217	-	-	-	-	2592	3513	4608
Speed Maximum (rpm)	6500	4600	4400	4000	3400	3000	2700	2300	2090	1750	1570	1390	1290
Torque Nominal (Nm)	53	110	175	265	465	720	1020	2450	3390	5080	8500	11500	15300
Torque Maximum (Nm)	106	220	350	530	930	1420	2040	4900	6780	10160	17000	23000	30400



### Pin

The pins are crafted from high-strength hexagonal steel bars, offering superior grip, durability, and corrosion resistance for reliable performance in demanding cone ring coupling applications.

Part Number	To Suit
GC1-3	MC30-42
GC1.3/4-3	MC20
GC2.3/4-4	MC75-105
GC4.1/4-3	MC120-150



### Pin Nut Rubber Assembly

The pin and nut rubber assembly in cone ring couplings is crucial for smooth, efficient, and long-lasting machinery operation. It provides flexibility, dampens vibrations, absorbs shocks, and reduces maintenance needs, ensuring reliable performance and longevity.

Part Number	To Suit
GC1-5	MC30-42
GC1.3/4-5	MC48-70
GC2.3/4-5	MC75-105
GC4.1/4-5	MC120-150



### Rubber Ring

The rings are made from synthetic rubber, offering excellent flexibility, durability, and resistance to wear and chemicals. These properties ensure reliable performance and longevity.

Part Number	To Suit
GC3/4-4 / GC3/4-3	MC20
GC1.3/4-4	MC48-70
GC4.1/4-4	MC120-150
GC1-4	MC30-42



### Bush Half

The bush halves are crafted from high-grade cast iron, ensuring exceptional strength, durability, and wear resistance. This robust construction provides reliable performance and longevity, making them ideal for demanding applications.

Part Number
MC020-BHB ~ MC150-BHB
MCT042-BHB ~ MCT150-BHB



### Pin Half

The pin halves, incorporating a high-grade cast iron pin and nut rubber assembly, offer superior durability and resilience. This design ensures effective vibration damping, shock absorption, and ease of maintenance, providing reliable performance and long-lasting operation in challenging environments.

Part Number
MC020-PHB ~ MC150-PHB
MCT042-PHB ~ MCT150-PHB



### Complete

The coupling consists of two flanges interlocked with a number of elements. The rubber rings absorb commonly encountered misalignment, shock and vibration.

The Pin and Rubber design ensures trouble-free maintenance, as they can be removed and changed without the need to take the coupling off the shafts.

Part Number
MC020 ~ MC150
MCT042 ~ MCT150

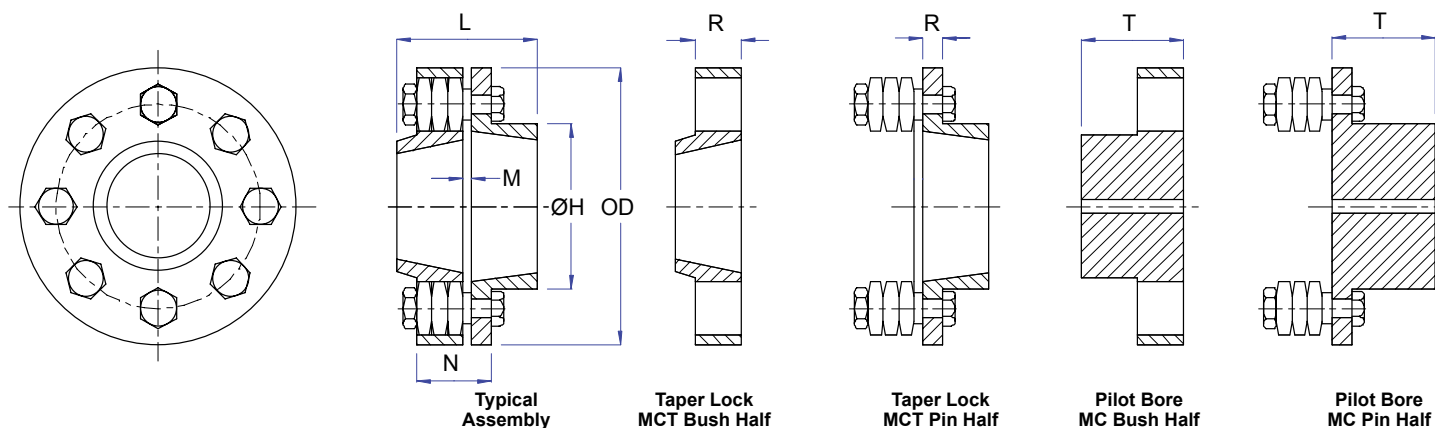

Bore	MC020	MC030	MC038	MC042	MC048	MC058	MC070	MC075	MC085	MC105	MC120	MC135	MC150
Taper Lock Bush Size: Bush Half MCT	-	-	-	1610	2012	2517	3020	-	3535	4040	4040	4545	5050
Taper Lock Bush Size: Pin Half MCT	-	-	-	1210	1610	2012	2517	-	3030	3535	4040	4545	5050
Maximum Bore: TL Pin Half MCT	-	-	-	42	50	65	75	-	90	100	100	110	125
Maximum Bore: TL Bush Half MCT	-	-	-	32	42	50	65	-	75	90	100	110	125
Maximum Bore: Pilot Bore Pin Half MC	28	38	42	48	55	65	80	85	90	115	120	135	150
Max. Bore: Pilot Bore Bush Half MC	20	32	38	42	48	58	70	75	85	105	110	125	135

Dimensions	MC020	MC030	MC38	MC042	MC048	MC058	MC070	MC075	MC085	MC105	MC120	MC135	MC150
OD - Outside Diameter	88	127	132	146	171	193	216	254	279	330	370	419	457
ØH - Hub Diameter: Pin Halves	35	64	70	82	94	110	132	142	162	200	206	230	256
ØH - Hub Diameter: Bush Halves	44	51	64	70	82	97	117	127	147	180	206	230	256
L - Length: MC	OA	88	102	118	128	142	159	183	207	241	270	300	336
L - Length: MCT		-	-	56	63	82	102	-	172	198	209	235	260
M-Gap		6	6	6	6	6	7	7	7	7	7	7	7
T-Flange Length: Pin Halves		12	12	12	17	17	17	30	30	30	46	46	46
T-Flange Length: Bush Halves		26	26	26	33	33	33	56	56	56	76	76	76
T-LTB: MC Pin & Bush Halves		41	48	56	61	68	76	88	100	117	132	147	117
T-LTB: MCT Pin Halves		-	-	25	32	44	51	-	89	102	102	115	102
T-LTB: MCT Bush Halves		-	-	25	25	32	44	-	76	89	102	115	89

Spares	MC020	MC030	MC038	MC042	MC048	MC058	MC070	MC075	MC085	MC105	MC120	MC135	MC150
Pins per coupling	6	4	6	8	6	8	10	8	10	12	10	12	14
Rubbers per coupling	18	12	18	24	18	24	30	32	40	48	40	48	56
Pin Size	GC1.3/4-3	GC1-3	GC1-3	GC1-3	GC1.3/4-3	GC1.3/4-3	GC1.3/4-3	GC2.3/4-3	GC2.3/4-3	GC2.3/4-3	GC4.1/4-3	GC4.1/4-3	GC4.1/4-3
Ring Size: Rubber	GC3/4-3	GC1-4	GC1-4	GC1-4	GC1.3/4-4	GC1.3/4-4	GC1.3/4-4	GC2.3/4-4	GC2.3/4-4	GC2.3/4-4	GC4.1/4-4	GC4.1/4-4	GC4.1/4-4

Mass (kg)	MC020	MC030	MC038	MC042	MC048	MC058	MC070	MC075	MC085	MC105	MC120	MC135	MC150
MC Coupling	OA	3.5	5.0	6.3	4.0	14	20	37	49	77	120	163	210
MCT Coupling	-	-	-	5.5	9.0	11	-	44	14.2	72	108	144	181

All measurements are in mm

LTB: Length Through Bore.

TF: Taper Fit Bush to suit MCT Coupling.



Curved Jaw Couplings are compact and lightweight, designed for high torque and high-speed applications.

The design features crowning of the spider elements, which improves torsional softness and allows better misalignment capabilities. Available with three types of urethane elements, curved jaw couplings offer higher power ratings than conventional straight jaw types.

They are available in two hub types, pilot bore and a taper fit design, making replacements quick and easy.

Each complete coupling requires two hubs and one element also called a spider, with bushes needed for taper fit couplings.

These couplings ensure efficient operation, reduced vibration, and enhanced power transmission in various industrial applications.



### Features & Benefits

- ▶ High Torque capacity for size
- ▶ Compact design
- ▶ Low weight for reduced inertia
- ▶ Machined surfaces for extended life
- ▶ Absorbs shock loads
- ▶ Vibration dampening

### Coupling Model Selection

- ▶ Refer to the Power Rating tables.
- ▶ Select the Element type "Yellow 92A Shore", "Red 98A Shore" or "Green 64D Shore".
- ▶ Read down the left column to the required speed then read across horizontally until the design power is exceeded to select the coupling model. If the exact speed is not shown calculate based on power rating per/100rpm shown in the first column.

### Bore Dimensions

Check maximum bore dimensions and select from:

- ▶ Pilot Bore model to be machined to required bore and key or
- ▶ Taper Bore option.

### Selection via Torque Calculation Method

#### Torque

Calculate torque applied to the coupling by using this formula.

$$\text{Torque (Nm)} = \frac{9550 \times \text{Power kW}}{\text{Speed (rpm)}}$$

#### Service Factor

Apply the service factor to the torque figure in Nm, this is the design torque rating

#### Coupling Torque Ratings

Check the torque ratings for the Yellow 92A Shore, Red 98A Shore or Green 64D Shore as shown in the dimensions tables on the previous pages. Select a suitable coupling that exceeds the design torque rating.

#### Bore Dimensions

Check maximum bore dimensions and select from pilot bore model to be machined to required bore and key or taper fit option in available metric and imperial bore sizes.

## Pilot Bore

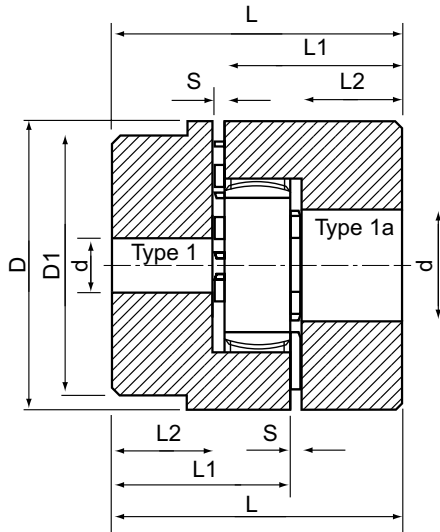

Type	Hub Type	Max Speed RPM	Rated Torque (Nm)			D	D1	d-min	d-max	S	L1	L2	L	Mass kg/hub
			92A SH Yellow	98A SH Red	64D SH Green									
GE14	1	17000	7.5	12.5	16	30	22	6	16	1	32	20	51	0.12
	1a													
GE19	1	19000	10	17	21	40	32	6	19	1	39	25	65	0.19
	1a							19	24					
GE24	1	14000	35	60	75	56	40	9	24	1	46	30	77	0.38
	1a							22	28					
GE28	1	11800	95	160	200	65	48	10	28	1.5	52.5	35	89	0.62
	1a							28	38					
GE38	1	9500	190	325	405	80	66	12	38	1	66	45	112	1.36
	1a							38	45					
GE42	1	8000	265	450	560	95	75	14	42	1	73	50	124	2.03
	1a							42	55					
GE48	1	7100	310	525	655	105	85	15	48	1.5	80.5	56	138	2.85
	1a							48	60					
GE55	1	6300	410	685	825	120	98	20	55	2	91	65	158	4.32
	1a							55	70					
GE65	1	5600	625	940	1175	135	115	22	65	1.5	105.5	75	182	6.66
	1a							22	65					
GE75	1	4750	1280	1920	2400	160	135	30	75	1	120	85	206	10.48
	1a							30	75					
GE90	1	3750	2400	3600	4500	200	160	40	90	1.5	139.5	100	241	17.89
	1a						180	40	90					

Measurements are in mm. Hub Types: 1 = Stepped Hub 1a = Full Hub

## Taper Bore

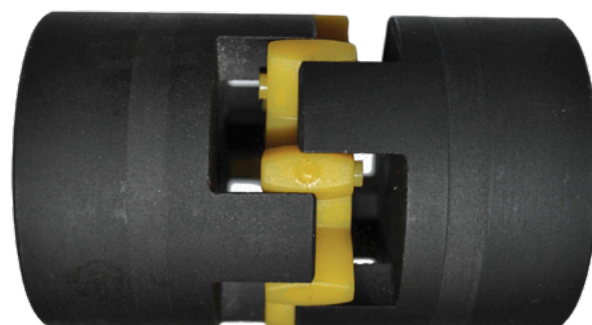
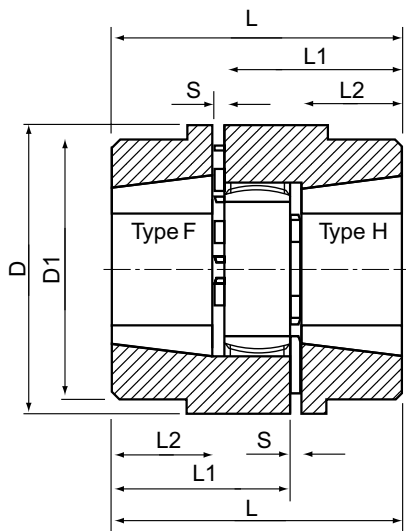

Type	Hub Type	Rated Torque (Nm)			Brush Size	Max Bore	D	D1	S	L1	L2	L	Mass kg/hub
		92A SH Yellow	98A SH Red	64D SH Green									
24 F	14000	35	60	75	1008	25	56	-	1.0	39.0	23.0	63.0	0.31
24 H					1008	25	56	-	1.0	39.0	23.0	63.0	0.31
28 F	11800	95	160	200	1108	28	65	-	1.5	40.5	23.0	65.0	0.46
28 H					1108	28	65	-	1.5	40.5	23.0	65.0	0.46
38 F	9500	190	325	405	1108	28	80	78	1.0	44.0	23.0	68.0	0.79
38 H					1108	28	80	78	1.0	44.0	23.0	68.0	0.79
42 F	8000	256	450	560	1610	42	95	94	1.0	49.0	26.0	76.0	1.10
42 H					1610	42	95	94	1.0	49.0	26.0	76.0	1.10
48 F	7100	310	525	655	1615	42	105	104	1.5	63.5	39.0	104.0	2.07
48 H					1615	42	105	104	1.5	63.5	39.0	104.0	2.07
55 F	6300	410	685	825	2012	50	120	118	2.0	59.0	33.0	94.0	2.22
55 H					2012	50	120	118	2.0	59.0	33.0	94.0	2.22
65 F	5600	625	940	1175	2012	50	135	133	1.5	63.5	33.0	98.0	3.14
65 H					2517	65	135	133	1.5	75.5	45.0	122.0	4.03
75 F	4750	1280	1920	2400	2517	65	160	135	1.0	81.0	46.0	128.0	4.69
75 H					3020	75	160	135	1.0	87.0	52.0	140.0	4.99
90 F	3750	2400	3600	4500	3020	75	200	160	1.5	91.5	52.0	145.0	7.74
90 H					3525	100	200	160	1.5	103.5	64.0	169.0	8.74

All dimensions are in mm.

## Elements

Curved Jaw coupling elements are designed for versatile and reliable performance across various industrial applications. Made from high-quality polyurethane (PUR), these couplings are available in different shore hardnesses to meet specific requirements.

### Yellow 92A Shore (92SHA)

The Yellow 92A SHA has good damping and average elasticity, making it suitable for all hub materials.

- ▶ Size: 14 - 90
- ▶ Material: Polyurethane (PUR)
- ▶ Operating Temperature: -40 °C to +90 °C



### Red 98A Shore (98SHA)

The Red 98A Shore transmits high torques with average damping and is recommended for hub materials such as steel, GJL, and GJS.

- ▶ Size: 14 - 90
- ▶ Material: Polyurethane (PUR)
- ▶ Operating Temperature: -30 °C to +90 °C



### Green 64D Shore (64DSHD)

The Green 64D Shore transmits very high torques with low damping, is suitable to shift critical speeds, and is resistant to hydrolysis, with recommended hub materials being steel and GJS.

- ▶ Size: 14 - 90
- ▶ Material: Polyurethane (PUR)
- ▶ Operating Temperature: -30 °C to +110 °C



14

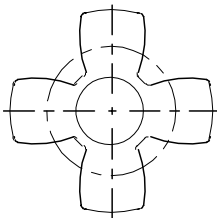

19

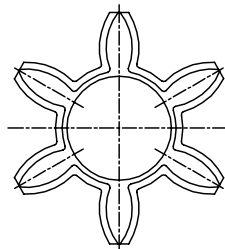

24 - 65

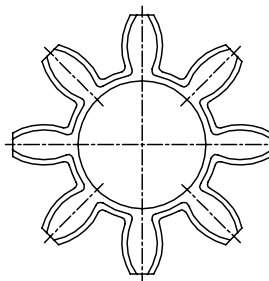

75 - 160

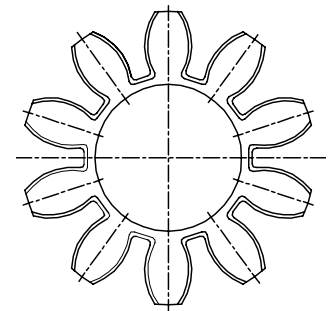

Power Ratings (Kw)	RPM	GE14	GE19	GE24	GE28	GE38	GE42	GE48	GE55	GE65	GE75	GE90
Yellow 92 Shore Element	100	0.07	0.1	0.37	1	1.99	2.78	3.25	42.9	6.55	13.4	25.1
	500	0.38	0.52	1.83	4.98	9.95	13.9	16.2	21.5	35.7	67	126
	700	0.54	0.73	2.56	6.97	13.9	19.4	22.7	30.1	45.8	93.8	176
	720	0.56	0.75	2.64	7.16	14.3	20	23.4	30.9	47.1	96.5	181
	800	0.62	0.84	2.93	7.96	15.9	22.2	26	34.3	52.4	107	201
	900	0.7	0.94	3.29	8.96	17.9	25	29.2	38.6	58.9	121	226
	960	0.75	1.01	3.51	9.55	19.1	26.6	31.2	41.2	62.8	129	241
	1000	0.78	1.05	3.66	9.95	19.9	27.8	32.5	42.9	65.5	134	251
	1200	0.93	1.26	4.39	11.9	23.9	33.3	39	51.5	78.5	161	302
	1400	1.09	1.47	5.12	13.9	27.9	38.9	45.4	60.1	91.6	188	352
	1440	1.12	1.51	5.27	14.3	28.7	40	46.7	61.8	94.2	193	362
	1500	1.16	1.57	5.49	14.9	29.9	41.6	48.7	64.4	98.2	201	377
	1800	1.39	1.88	6.59	17.9	35.8	50	58.4	77.3	118	241	452
	2000	1.55	2.09	7.32	19.9	39.8	55.5	64.9	85.9	131	268	503
	2880	2.23	3.02	10.5	28.7	57.3	79.9	93.5	124	188	386	724
	3000	2.32	3.14	11	29.9	59.7	83.3	97.4	129	196	402	754
4000	3.1	4.19	14.6	39.8	79.6	111	130	172	262	536	—	
Red 98 Shore Element	100	0.13	0.18	0.63	1.68	3.4	4.71	5.5	7.17	9.84	20.1	97.7
	500	0.66	0.89	3.14	8.38	17	23.6	27.5	35.9	49.2	101	189
	700	0.93	1.25	4.4	11.7	23.8	33	38.5	50.2	68.9	141	264
	720	0.95	1.28	4.52	12.1	24.5	33.9	39.5	51.6	70.9	145	271
	800	1.05	1.42	5.02	13.4	27.2	37.7	44	57.4	78.7	161	302
	900	1.18	1.6	5.65	15.1	30.6	42.4	49.5	64.6	88.6	181	339
	960	1.27	1.71	3.51	16.1	32.7	45.2	52.8	68.9	94.5	193	362
	1000	1.32	1.78	3.66	16.8	34	47.1	55	71.7	98.4	201	377
	1200	1.58	2.14	4.39	20.1	40.8	56.5	66	86.1	118	241	452
	1400	1.84	2.49	5.12	23.5	47.6	66	77	100	138	281	528
	1440	1.89	2.56	5.27	24.1	49	67.9	79.2	103	142	290	543
	2880	3.83	5.2	18.1	48.4	97.9	135.7	158.4	206.5	283.4	578.9	1085.8
Green 64 Shore Element	100	0.16	0.2	0.8	2.1	4.2	5.8	6.8	8.8	12.1	24.7	46.4
	500	0.81	1.1	3.9	10.3	20.9	29	33.8	44.2	60.5	124.2	232.5
	700	1.14	1.5	5.4	14.4	29.3	40.6	47.4	61.8	84.8	173.4	324.7
	720	1.16	1.6	5.6	14.9	30.1	41.7	48.7	63.5	87.2	178.4	333.3
	800	1.3	1.8	6.2	16.5	33.5	46.4	54.1	70.6	96.8	198	371.5
	900	1.46	2.0	7.0	18.6	37.6	52.2	60.9	79.5	109	222.6	417
	960	1.55	2.1	7.4	19.8	40.2	55.6	64.9	84.8	116.2	237.4	445.3
	1000	1.62	2.2	7.7	20.7	41.8	57.9	67.7	88.2	121	247.2	463.7
	1200	1.95	2.6	9.3	24.7	50.2	69.5	81.2	105.9	145.1	296.4	556
	1400	2.26	3.1	10.8	28.9	58.6	81.2	94.7	123	169.7	345.6	649.4
1440	2.33	3.2	11.1	29.6	60.3	83.5	97.4	126.7	174.7	356.7	667.9	
2880	4.69	6.3	22.2	59.6	120.4	166.8	195.0	254	348.5	711.9	1335.5	

The TransDrive HRC Coupling is a proven performer, consisting of two cast iron flanges and a rubber element, which performs under compression.

The modular design allows for a simple fitting and easy maintenance whilst the rubber element absorbs shock loading.

TransDrive couplings are available in a wide range of specifications, including Nitrile and polyurethane elements, as well as pilot bore and taper lock configurations.



## Selection Procedure

<b>Service Factor</b>	Determine appropriate service factor from the table below.
<b>Design Power</b>	Multiply running of driven machine by the service factor. This gives the Design Power which is used as a basis for coupling selection.
<b>Coupling Size</b>	Refer to the Power Ratings Table and read across from the appropriate speed until a power equal to or greater than the Design Power is found. The size of the coupling required is given at the head of that column.
<b>Bore Size</b>	From the Dimension Table, check that the required bores can be accommodated.

## Example

A shaft coupling is required to transmit 70kW between a 1200 rev/min DC electric motor and a Banbury Mixer running 8hrs/day. Motor shaft is 70mm and the mixer shaft is 75mm.

<b>Service Factor</b>	From the table below the service factor is 2.5.
<b>Design Power</b>	Design Power is $70 \times 2.5 = 175\text{kW}$ .
<b>Coupling Size</b>	Reading across from 1200 rev/min in the speed column of the Power Ratings Table; 251kW is the first power to exceed the required 175kW (Design Power). The size of the coupling at the head of this column is 230.
<b>Bore Size</b>	The Dimensions Table, shows that both shaft diameters are within the bore range available.

## Service Factors

Special Classes <sub>1</sub>	Type of Driving Unit					
	Electric Motors Steam Turbines			Internal Combustion Engines Steam Engines Water Turbines		
	Hours Per Day Duty			Hours Per Day Duty		
Driven Machine Class <sub>2</sub>	8 and under	Over 8 to 16 inclusive	Over 16	8 and under	Over 8 to 16 inclusive	Over 16
Uniform	1.00	1.12	1.25	1.25	1.40	1.60
Moderate Shock <sub>3</sub> *	1.60	1.80	2.00	2.00	2.24	2.50
Heavy Shock <sub>4</sub> **	2.50	2.80	3.12	3.12	3.55	4.00

\*It is recommended that top clearance keys are fitted for applications where load fluctuation is expected.

\*\*For Centrifugal Compressor multiply Service Factor by an additional 1.15.

- For applications where substantial shock, vibration and torque fluctuation occur, and for reciprocating machines, e.g. internal combustion engines, piston type pumps and compressors, refer to TransDrive Power Transmission with full machine details for torsional analysis.
- Agitators, Brewing Machinery, Centrifugal Compressors\*\*, Conveyors, Centrifugal Fans and pumps, Generators, Sewage Disposal Equipment.
- Clay working machinery, Crane Hoists, Laundry machinery, Wood working machinery, Machine Tools, Rotary Mills, Paper Mill machinery, Textile machinery.
- Reciprocating conveyors, Crushers, Shakers, Metal Mills, Rubber machinery. (Banbury Mixers and Mills, Reciprocating Compressors).

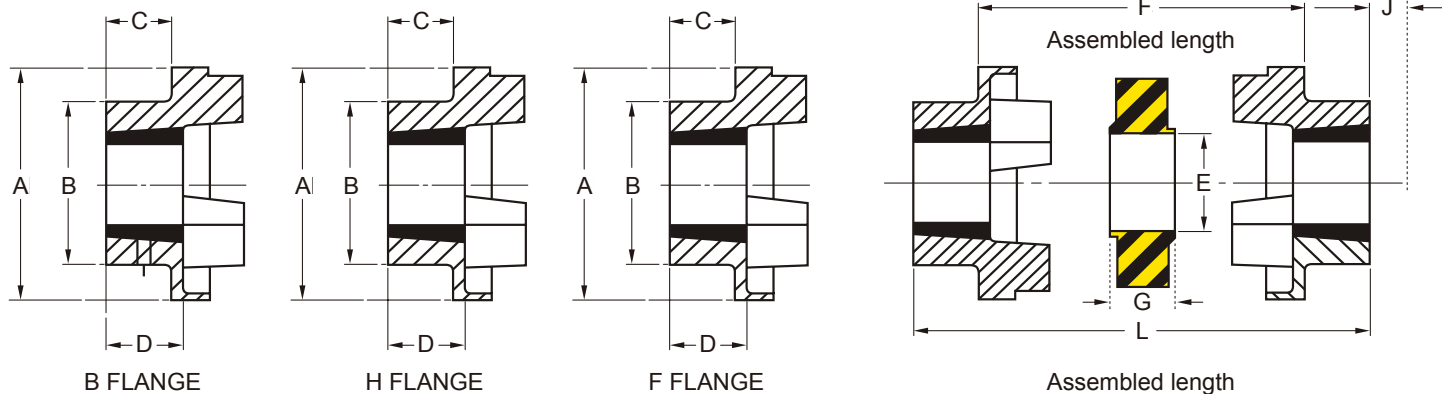

Size	Bush	Bore		C	D	Bored to Size				Dia. A	Dia. B	Dia. C	F	G	L1	L2	L3	J
		Max	Min			Bore+		C	D									
						Max	Min											
70	1008	25	9	19.0	23.5	32	8	21	25	69	60	31	27	18	65	66.5	68	29
90	1108	28	9	18.5	23.5	38	8	26	30	85	65	32	32.5	22.5	69.5	75	82.5	29
110	1610	42	11	18.5	26.5	55	8	37	45	112	100	45	45	29	82	100.5	119	38
130	1610	42	14	17.5	26.5	60	36	47	55	130	105	50	54	36	89	117.5	145	38
150	2012	50	14	23.0	33.5	65	40	50	60	150	115	62	61	40	107	133.5	160	42
180	2517	60	16	34.0	46.5	80	46	58	70	180	125	77	74	49	142	165.5	189	48
230	3020	75	25	39.5	52.5	100	52	77	90	225	155	99	85.5	59.4	142	202	239.5	55
280	3535	90	35	74.0	90.5	115	62	90	105	275	185	119	107.5	74.5	142	270	284.5	67

All dimensions are in mm.

L1 is the length with assembly combinations F.F - H.H F.H. / L2 is the length with assembly combinations F.B - H.B / L3 is the length with assembly combinations B.B  
J is the wrench clearance required for tightening and loosening the bush on the shaft. The use of a shortened key will allow this dimension to be reduced.

+ Bore limit H8 unless specified otherwise.

## Physical Characteristics

Size	Power Rating Per 100 rev/min	Maximum Speed* (rev/min)	Torque Rating (Nm)		Moment of Inertia MR2 (kgm <sup>2</sup> )	Torsional Stiffness (Nm/o)	Maximum Misalignment		Mass (kg)
			Normal	Maximum			Parallel	Axial	
70	0.33	9100	31.5	72	0.00085	10.2	0.3	+0.20	1.00
90	0.84	7400	80	180	0.00115	25.5	0.3	+0.49	1.17
110	1.168	5630	160	360	0.00400	48.0	0.3	+0.61	5.00
130	3.30	4850	315	720	0.00780	84.0	0.4	+0.79	5.46
150	6.28	4200	600	1500	0.01810	176	0.4	+0.92	7.11
180	9.95	350	950	2350	0.04340	240	0.4	+1.09	16.60
230	20.9	2800	2000	5000	0.12068	336	0.5	+1.32	26.00
280	33.0	230	3150	7200	0.44653	960	0.5	+1.70	50.00

Maximum Coupling speeds are calculated using an allowable peripheral speed for hub material. For selection of smaller sizes with speeds in excess of 3600 rev/min - Power Transmission.

Mass is for Coupling with mid-range bore Taper Bushes.

For speeds below 100rpm or intermediate speeds use normal torque rating.

## Power Ratings (kW)

Speed rev/min	Coupling Size							
	70	90	110	130	150	180	230	280
100	0.33	0.84	1.68	3.30	6.28	9.95	20.9	33.0
200	0.66	1.68	3.35	6.6	12.6	19.9	11.9	65.0
400	1.32	3.35	6.70	13.2	25.1	39.8	83.8	132
600	1.98	5.03	10.1	19.8	37.7	59.7	126	198
720	2.37	6.03	12.1	23.8	45.2	71.6	151	238
800	2.64	6.70	13.4	26.4	50.3	79.6	168	264
960	3.17	8.04	16.1	31.7	60.3	95.5	201	317
1200	3.96	10.1	20.1	39.6	75.4	119	251	396
1440	4.75	12.1	24.1	47.5	90.5	143	302	475
1600	5.28	13.4	26.8	52.8	101	159	335	528
1800	5.94	15.1	30.2	59.4	113	179	377	594
2000	6.60	16.8	33.5	66.0	126	199	419	660
2200	7.26	18.4	36.9	72.6	138	219	461	726
2400	7.92	20.1	40.2	79.2	151	239	503	—
2600	8.58	21.8	43.6	85.8	163	259	545	—
2880	9.50	24.1	48.3	95	181	286	—	—
3000	9.90	25.1	50.3	99	188	298	—	—
3600	11.9	30.1	60.3	118	226	—	—	—

For speeds below 100 rev/min, and intermediate speeds, use normal torque ratings.



## Jaw Flex L Series Wrap Couplings

The L-series wrapped jaw couplings provide a reliable, flexible, and easy-to-maintain solution for connecting shafts in various industrial applications. Their design ensures efficient torque transmission, vibration damping, and adaptability to different operational requirements, making them a preferred choice for many engineers and maintenance professionals.



### Features & Benefits

- ▶ Wrap-Around design allows for quick installation and replacement without disassembling the hubs
- ▶ Available in multiple materials (NBR, Polyurethane and Hytrel) to suit specific application needs
- ▶ Compact three-piece construction simplifies maintenance and reduces downtime
- ▶ Capable of transmitting torque from 3.5 to 280Nm, accommodating various power requirements

### Applications

- ▶ Pumps and Compressors: Ensuring reliable and smooth operation by compensating for misalignment and absorbing shocks.
- ▶ Conveyors: Providing robust and flexible connections that can handle varying loads and speeds.
- ▶ General Industrial Machinery: Offering versatile and maintenance-friendly solutions for various mechanical systems.

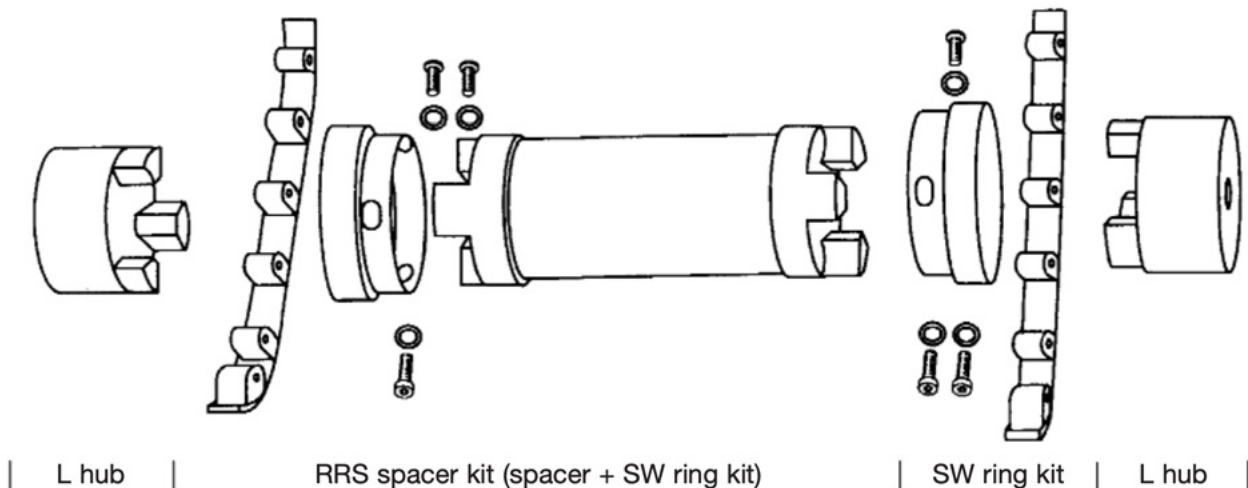

	L050	L070	L075	L095	L100	L110	L150	L190	L225
Spider	•	•	•	•	•	•	•	•	•
Snap Wrap				•	•	•	•	•	•
Kit				•	•	•	•	•	•
Pilot Bore Hub	•	•	•	•	•	•	•	•	•
Hytrel Spider	•	•	•	•	•	•	•	•	
Polyurethane Spider	•	•	•	•	•	•	•	•	
<b>Imperial (Inch)</b>									
3/8	•	•							
7/16				•					
1/2	•	•	•	•	•				
9/16				•					
5/8	•	•	•	•	•				
3/4		•	•	•	•	•			
7/8			•	•	•	•			
1			•	•	•	•	•		
1-1/8				•	•	•	•		
1-1/4					•	•	•	•	
1-3/8						•	•	•	
1-1/2						•	•	•	
1-5/8								•	
2								•	
<b>Metric (mm)</b>									
10	•	•							
12	•	•	•						
14	•	•	•	•					
16		•	•	•					
18		•	•	•	•				
19		•	•	•	•				
20			•	•	•	•			
22			•	•	•	•			
24				•	•	•	•		
25				•	•	•	•	•	
28				•	•	•	•	•	
30					•	•	•	•	
32					•	•	•	•	
35					•	•	•	•	
38					•	•	•	•	
40						•	•	•	
45							•	•	
48							•	•	
55								•	•
60								•	•

## Jaw Flex L Series Wrap Couplings

### Hub Half Pilot Bore

The jaw coupling hubs are precision-machined for smooth contact surfaces, easy alignment, and optimal balance. The modular hub design supports cross-model compatibility, offering flexibility and cost-efficiency. They come pre-bored and keyed to standard IEC motor shaft sizes, with taper fit options available for non-standard shafts.

The hubs are resistant to water, dust, oil, and grease, ensuring reliable performance in challenging environments, making them suitable for a wide range of industrial applications.

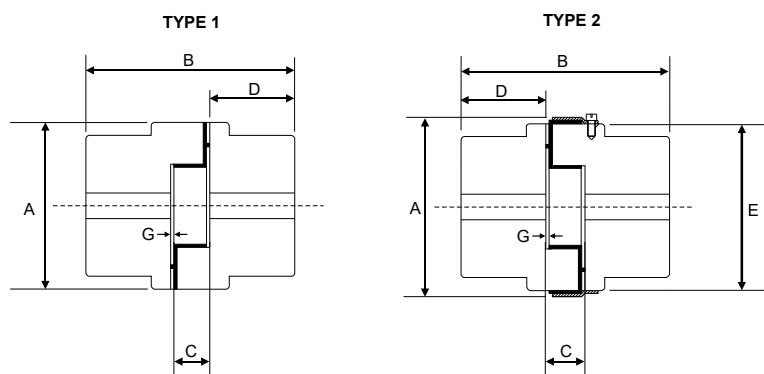

Coupling	Type	A	B	C	D	E	G	Stock Bore	Weight (kg)		Max Bore
									Stock Bore	Max Bore	
L050PB	1	27.4	43.4	12.2	15.7	-	1	6	-	-	15
L070PB	1	35	53	13	19	-	2	6	0.26	0.24	19
L075PB	1	44.5	53	13	19	-	2	6	0.45	0.39	22
L095PB	1 & 2	54	65	13	25	54	2	11	0.79	0.69	29
L100PB	1 & 2	65	86	19	35	65	2	11	1.55	1.32	35
L110PB	1 & 2	84	110	24	43	84	3	16	2.93	2.55	42
L150PB	1 & 2	96	113	25	45	96	3	16	4.06	3.51	48
L190PB	1 & 2	115	133	25	50	102	3	18	-	-	55
L225PB	1 & 2	127	155	25	55	108	3	18	-	-	65

All dimensions are in mm.

### Power Ratings (kW)

Coupling	Max. RPM	Torque (Nm)	Speed RPM					
			100	720	960	1440	2880	3600
L050PB	18000	3.51	0.037	0.26	0.35	0.53	1.73	2.17
L070PB	14000	5.77	0.06	0.43	0.58	0.87	3.61	4.51
L075PB	11000	11.9	0.12	0.9	1.2	1.8	5.78	7.22
L095PB	9000	25.8	0.27	1.95	2.59	3.89	16.73	20.91
L100PB	7000	55.4	0.58	4.18	5.58	8.36	31.77	39.71
L1100PB	5000	105	1.10	7.95	10.59	15.88	44.93	56.16
L150PB	4000	150	1.56	11.23	14.98	22.46	60.28	75.35
L190PB	3600	200	2.09	15.07	20.09	30.14	84.4	105.5
L225PB	3600	280	2.93	21.09	28.13	42.2	84.4	105.5

# Jaw Flex L Series Wrap Couplings

## Hub Half Taper Lock

The jaw coupling hubs are precision-machined for smooth contact surfaces, easy alignment, and optimal balance. The modular hub design supports cross-model compatibility, offering flexibility and cost-efficiency. They are also available come pre-bored and keyed to standard IEC motor shaft sizes, with taper fit options available for non-standard shafts.

The hubs are resistant to water, dust, oil, and grease, ensuring reliable performance in challenging environments, making them suitable for a wide range of industrial applications.

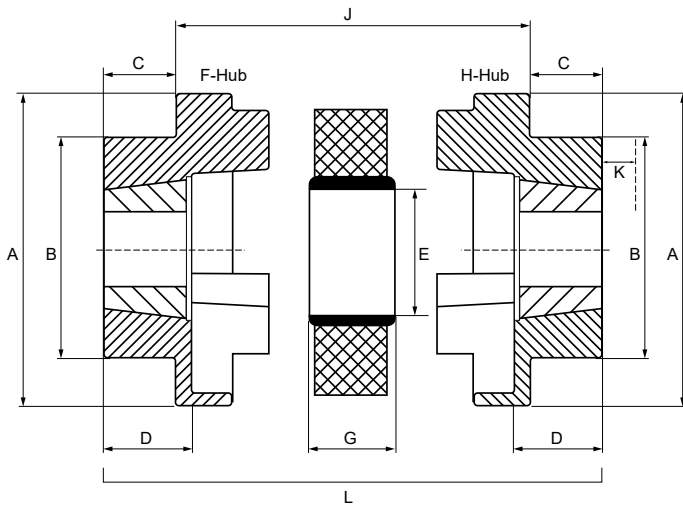

Size TF/TWNS	Bush			A		B	E	J	G	C	D	K	T
	Size	Max. Bore											
		mm	Inch	Taper Lock	T - Type 1								
L100	1108	28	1 1/8	65	78	65	27	44	18	10.5	23.5	29	65
L110	1210	32	1 1/4	84	96	84	35	48	22	13.5	26.5	38	75
L150	1210	32	1 1/4	96	111	96	35	55	25	11.5	26.5	38	78
L190	1610	42	1 5/8	115	129	102	45	63	25	7.5	26.5	38	78
L225	2012	50	2	127	142	108	45	63	25	14.5	33.5	42	92

All measurements are in mm unless otherwise stated.

K is the wrench clearance required for tightening and loosening the bush on the shaft. The use of shortened key will allow this dimension to be reduced. Couplings can be supplied with F/F or H/H or F/H flange as required.

Weight is for flange without Bore.

# Jaw Flex L Series Wrap Couplings

## Spiders

The L type jaw coupling closed center elements, also called spiders, are elastomers designed to transmit torque and accommodate misalignments in various industrial applications. These elements operate in compression and come in different designs to meet specific application needs.

### Nitrile Butadiene Rubber (NBR)

The NBR, the standard acts like natural rubber in resilience and elasticity.

- ▶ Oil-resistant
- ▶ Highly flexible
- ▶ Operating temperature -40° to 100° C (-40° to 212° F).

### Polyurethane (PUR)

The PUR tolerates higher torque and is more resistant to oil and chemicals.

- ▶ 1.5x times the torque capacity of NBR,
- ▶ Resistant to oil and chemicals
- ▶ Operating temperature -34° to 71° C (-30° to 160° F).

### Hytrel (HYT)

HYT elements are engineered to excel in applications requiring resistance to extreme temperatures and high torque.

- ▶ High torque
- ▶ High temperature
- ▶ Operating temperature -51° to 121° C (-60° to 250° F).



Part No.	Material			A	DC	H
	NBR	PU	HYT			
SW0235	X	-	-	0.62	-	-
SW050	X	X	X	1.07	-	-
SW070	X	X	-	1.38	-	-
SW075	X	-	-	1.75	-	-
SW095	X	-	-	2.12	0.18	0.88
SW100	X	-	-	2.54	0.25	1.03
SW110	X	-	X	3.31	NBR 0.25	1.19
					HYT 0.18	
SW150	X	-	X	3.75	NBR 0.31	1.25
					HYT 0.21	
SW190	X	-	X	4.50	NBR 0.31	1.38
					HYT 0.18	
SW225	X	-	X	4.98	NBR 0.38	1.75
					HYT 0.18	

All dimensions are in inches.

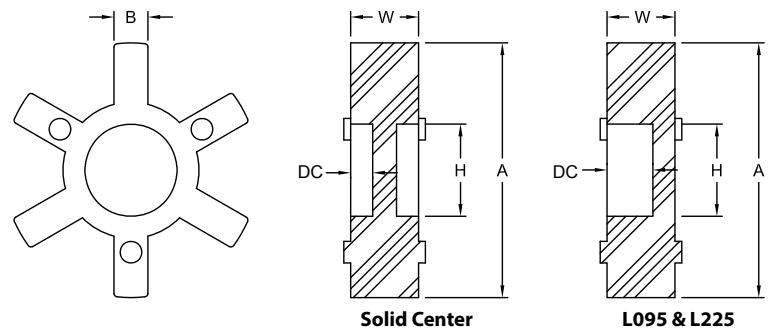

## Jaw Flex L Series Wrap Couplings

### Spacer

The spacer, also known as the Radially Removable Spacer (RRS) or LSW Type, provides shaft drop-out, facilitating easy maintenance. The center "drop out" section of this coupling ensures proper shaft separation and allows for easy elastomer installation without disturbing the hubs or requiring the realignment of shafts.

The spacer is designed for heavy-duty applications that require reliable power transmission and accommodation for minor shaft misalignments. This coupling features robust construction and offers exceptional torsional flexibility and vibration dampening capabilities when paired with rubber elements.

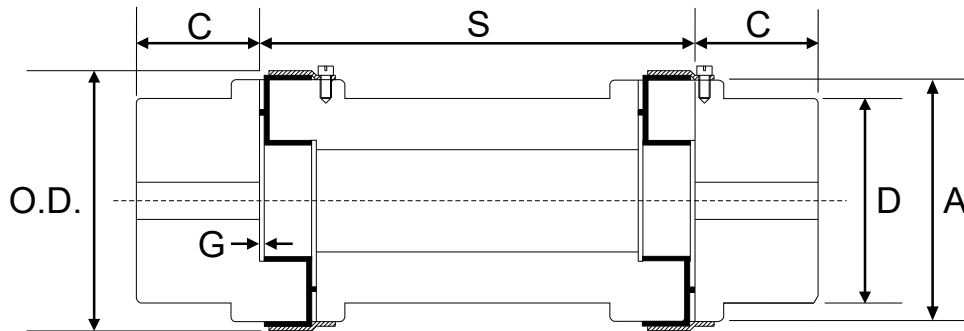

Part No.	Bore		A	Length Through Bore C	D	O.D.	Gap G	Spacer Length
	Min.	Max.						
RRS095/ 100 140	9	28	65	25	57	64	2	100/140
RRS100/ 100 140	12	35	85	35	76	78	2	100/140
RRS110/ 100 140	15	42	85	43	76	96	3	100/140
RRS150/ 100 140 180	15	48	96	45	80	111	3	100/140/180
RRS190/ 100 140 180	20	60	115	54	102	130	3	100/140/180
RRS225/ 100 140 180	20	65	127	64	111	142	3	100/140/180

All dimensions are in mm.

## Jaw Flex L Series Wrap Couplings

### Snap Wrap Element

The Snap Wrap Element, made of NBR (Nitrile Butadiene Rubber), allows for easy replacement of the spider without removing the hubs. This flexible, oil-resistant material operates within a temperature range of 40 to 100°C.

Quick spider replacement minimizes downtime. The element supports various alignment needs due to close shaft separation. NBR ensures durability and oil resistance.

- ▶ Maximum speed: 1,750RPM
- ▶ Torque Capacity: 144 to 1,728 in-lbs
- ▶ Operating Temperature: 40 to 100°C.



### Snap Wrap with Retaining Ring

The Snap Wrap Element with retaining ring and screws, allows for easy spider replacement without moving the hubs. Made of NBR (Nitrile Butadiene Rubber), the addition of the retaining ring allows the coupling to reach a maximum RPM of 3,600.

High-speed performance up to 3,600 RPM. Quick spider replacement reduces downtime. Supports various alignment needs with close shaft separation. NBR provides durability and oil resistance.

- ▶ Maximum speed: 3,600RPM
- ▶ Torque Capacity: 144 to 1,728 in-lbs
- ▶ Operating Temperature: 40 to 100°C.



Snap Wrap	Snap Wrap with Retaining Ring	AA	HH	W	B
SW095ELE	SW09KIT	2.56	1.06	0.44	0.36
SW100ELE	SW100KIT	3.08	1.37	0.61	0.43
SW110ELE	SW110KIT	3.87	1.50	0.75	0.45
SW150ELE	SW150KIT	4.56	1.75	0.88	0.59
SW190ELE	SW190KIT	5.18	2.25	0.88	0.60
SW225ELE	SW225KIT	5.44	2.75	0.88	0.73

All dimensions are in inches.

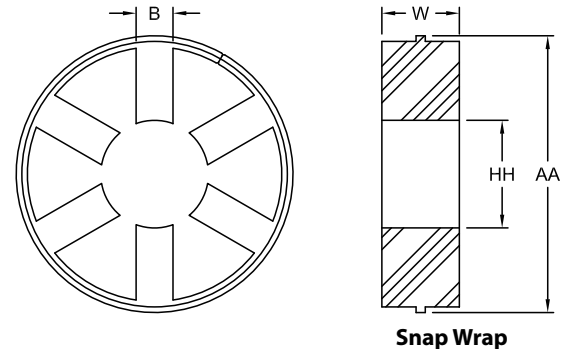

**Snap Wrap**

## NM Jaw Coupling

The "NM" series Jaw Coupling Full Unit consists of two hubs and a unique ring type element which dampens torsional vibrations and operates smooth and steady with high wear resistance.

The NM coupling weaving element restricts torsional oscillation, safeguarding machinery at critical speeds with excellent internal damping.

The NM coupling features a unique element that moves in a weaving pattern between the jaws. This element possesses excellent internal damping properties, allowing the coupling to restrict torsional oscillation and safeguard the connected machinery against potential harm when operating at critical speeds.

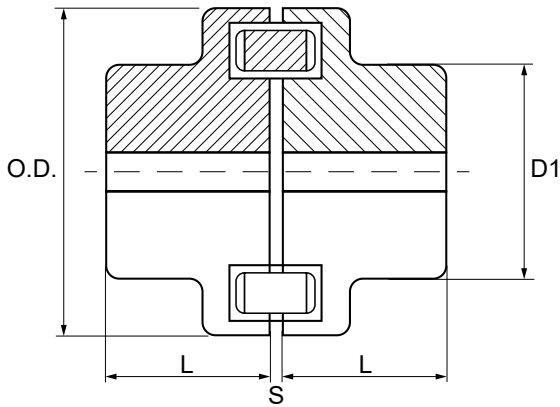

Size	Bore (mm)		OD	D1	L	S	Max. Speed (rpm)	Torque (Nm)		Power Rating kW / rpm	Weight (kg) / set
	Min	Max						Nominal	Max.		
NM-50	7	19	50	33	25	2.0±0.5	13500	12.74	22.54	1.33	0.52
NM-67	9	28	67	46	30	2.5±0.5	10000	21.56	39.2	2.26	0.93
NM-82	10	32	82	53	40	3.0±0.5	8000	49	88.2	5.13	1.78
NM-97	12	42	97	69	50	3.0±0.5	7000	102.9	186.2	10.78	3.46
NM-112	14	48	112	79	60	3.5±0.5	6000	163.66	294	17.14	5
NM-128	18	55	128	90	70	3.5±0.5	5000	261.66	470	27.40	7.9

All dimensions are in mm.

## Element

The elements are available in Perbunan (Pb72) material grade, which includes nitrile rubber (NBR) and has hardness options of 72 and 82 shore A. They can operate within a temperature range of -40°C to +120°C.

Products
NM-50
NM-67
NM-82
NM-97
NM-112
NM-128

All dimensions are in mm.





TransDrive SM series spacers combined with either cone ring couplings or tyre couplings provides efficient maintenance by providing room to move the driving or driven shafts without disturbing the mounting of the driving or driven machine.

Standard Distance Between Shaft Ends (DBSE) lengths of 100, 140 and 180mm are available.

### Selection Procedure

- ▶ Use the selection procedure to select a suitable Cone Ring / Tyre coupling.
- ▶ Select suitable Spacer taking into consideration the required shaft spacing.



Spacer Coupling attached to Cone Ring Coupling

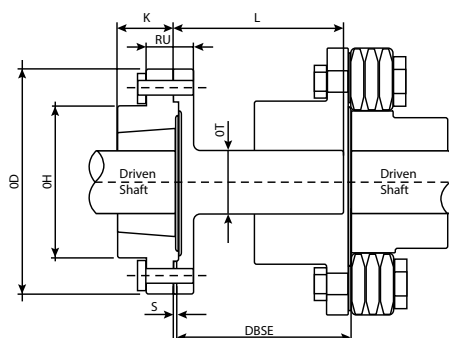

Spacer Coupling w/ Tyre Coupling

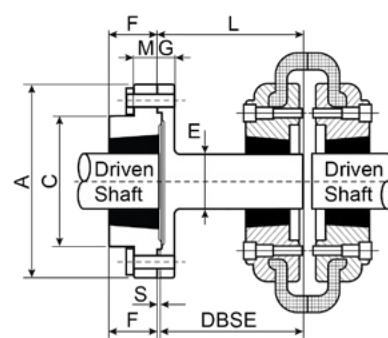

Dimensions	SM16	SM25	SM30	SM35
Use with Tyre Coupling	MC038 F50-F60	MC042 MC048 F70 F80 F80	MC058 F100 F110	MC070 MC075 F120 F140
Taper Fit Bush Size (Spacer Flange)	1615	2517	3030	3535
Taper Fit Bush Maximum Bore	42	65	75	90
OD / A - Outside Diameter	127	178	216	248
OH C - Hub Diameter	80	123	146	178
K* / F*	38	46	76	89
L -Length: 100mm DBSE*	94	94	-	-
L -Length: 140mm DBSE*	134	134	134	134
L -Length: 180mm DBSE*	-	174	174	174
R / M	18	22	51	63
S	6	6	6	6
OT / E	32	48	60	80
U / G	15	16	20	20

Mass	SM16	SM25	SM30	SM35
100mm DBSE (kg)	3.55	8.05	-	-
140mm DBSE (kg)	3.8	8.65	16.4	25.4
180mm DBSE (kg)	-	9.25	17.3	26.9

All values are in mm unless otherwise stated.

### Ordering Instructions

- ▶ SM Spacers are specified by the size end DBSE (eg. A SM35 spacer with a 140mm DBSE length is specified as a SM35-140)
- ▶ SM Spacers require a Taper Fit bush which must be ordered as a separate item (specifying bush size end the required bore).
- ▶ To order a complete Spacer coupling list the individual components of the coupling and spacer including required Taper Fit bushes.

The Dynamic Tyre Coupling is engineered to protect against swirl, twist, impact, and abrasion. With simple maintenance, no oil or grease required, and easy replacement without separating motors or connectors, it ensures seamless operations. Its versatile design allows for dissimilar connections with the same hub, while its polyurethane construction offers exceptional water and chemical resistance.



## Features & Benefits

- ▶ Facility protection for swirl and twist, impact and abrasion
- ▶ Very simple replacement and maintenance without oil and grease
- ▶ Very simple replacement without the separation of motor or connector on the related line due to its simple structure
- ▶ Possible for the dissimilar connection and assembling with same hub
- ▶ Polyurethane based for having good water resistance, chemical resistance
- ▶ Highest flexible elasticity on run
- ▶ Less noise

## Applications

- |                     |                          |                               |
|---------------------|--------------------------|-------------------------------|
| ▶ Agitator          | ▶ Fans                   | ▶ Pulp and Paper Mill         |
| ▶ Blower            | ▶ Generators             | ▶ Rubber Industry             |
| ▶ Compressor        | ▶ Pump                   | ▶ Steel Industry              |
| ▶ Conveyors         | ▶ Brewery and Distilling | ▶ Textile Mills               |
| ▶ Cranes and Hoists | ▶ Food Industry          | ▶ Aggregate Processing Cement |
| ▶ Elevators         | ▶ Lumber Industry        |                               |

## Service and Safety Factors

General Application	Service Factor	Industry Application	Service Factor
Agitator	1.5	Aggregate Processing Cement	2.0 - 3.0
Blower	1.0 - 1.5	Brewery and Distilling	1.0 - 2.0
Compressor	1.0 - 2.0	Food Industry	1.0 - 2.0
Conveyor	1.25 - 1.5	Lumber Industry	1.5 - 2.5
Cranes and Hoists	2.0 - 2.5	Power Industry	1.0 - 2.5
Elevators	1.0 - 2.0	Pulp and Paper-Mills	1.0 - 3.5
Fans	1.0 - 2.0	Rubber Industry	1.0 - 3.0
Generators	1.0 - 2.5	Steel Industry	2.0 - 4.5
Pumps	1.0 - 1.5	Textile	1.0 - 2.0

Running Status	Service Factor
1 For being continuous and light load weight	1.0
2 For being the various change of the rotary power	1.5
3 For being various and frequent variation on the turning force	2.0
4 For being the variation of the rotary power accompanying impact	2.5
5 For being high-impact load-weight accompanying slight retro-rotation	3.0
6 For being frequent retro-rotation accompanying high-impact	Consult

## Installation Tolerance

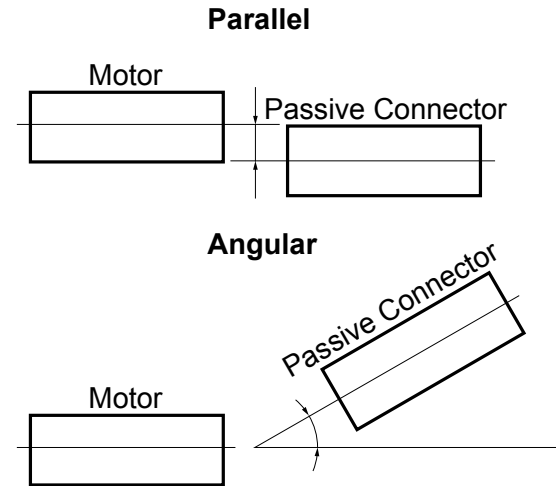
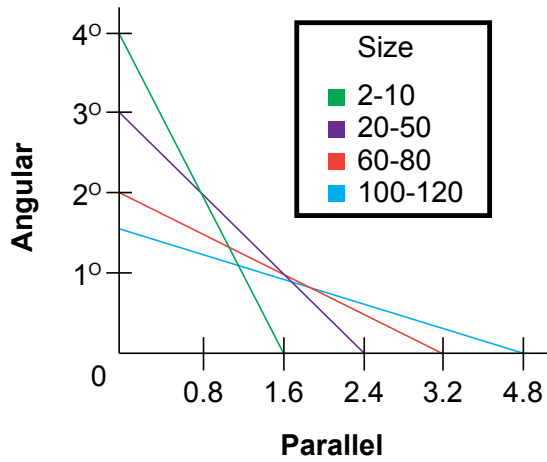

## Method of Assembly



1. Adjust the face of A and A' at same space
2. Adjust Hub's Minimum space
3. Assemble the bolts in the order of 2-2', 5-5', 3-3', 4-4', 6-6', 1-1'
4. Assemble the bolts in the middle part of the edge



1. Adjust the face of A and A' at same space
2. Adjust Hub's Minimum space
3. Assemble the bolts in the order of 2-2', 7-7', 3-3', 6-6', 1-1', 4-4', 8-8', 5-5'
4. Assemble the bolts in the middle part of the edge

## Dynamic® Standard Couplings

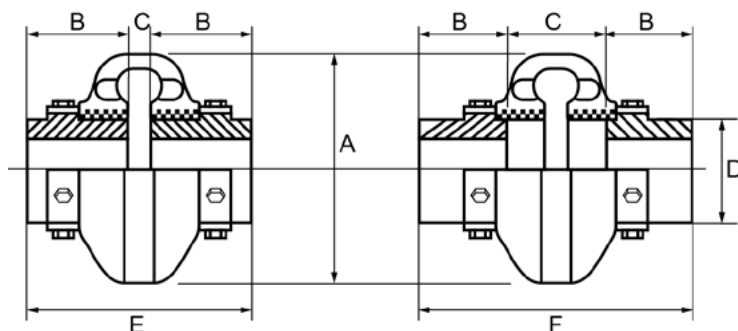
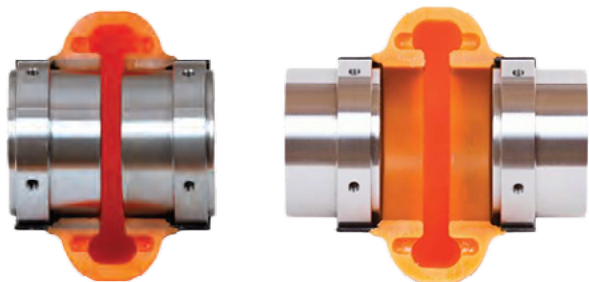

Dynamic Coupling No.	Torque (kgf.m)	Max. Bore (mm)	Max. rpm	Power Rating (kW/rpm)	Dimensions (mm)						
					A Outer Diameter	B Hub Length	C		D Hub Diameter	Total Length	
							Min. Shaft Spacing	Max. Shaft Spacing		E In	F Out
D-2	2.20	28	7500	0.0023	89	24	35	47	47	83	95
D-3	4.20	34	7500	0.0043	102	32	9	47	59	83	111
D-4	6.40	42	7500	0.0066	116	37	9	47	66	83	121
D-5	11.00	48	7500	0.0110	137	45	10	52	80	100	142
D-10	16.70	55	7500	0.0170	162	45	11	53	93	101	143
D-20	26.70	65	6600	0.0270	184	50	15	63	114	115	163
D-30	42.10	75	5800	0.0430	210	56	12	68	138	124	180
D-40	63.40	85	5000	0.0660	241	61	12	74	168	134	196
D-50	88.20	90	4200	0.0900	249	69	12	86	207	150	224
D-60	144.00	105	3800	0.1480	318	80	11	99	222	171	259
D-70	254.00	120	3600	0.2620	356	85	18	109	235	189	281
D-80	455.00	155	2000	0.4670	406	114	17	149	286	245	377
D-100*	980.00	171	1900	1.000	533	140	44	95	359	324	375
D-120*	1961	190	1800	2.000	635	152	57	124	448	362	429

All dimensions are in mm.

## Dynamic® Couplings with QD Hubs

QD Hubs provide quick and secure shaft attachment with a split taper design for easy installation and removal. Constructed from high-strength materials, these hubs ensure reliable performance and durability.

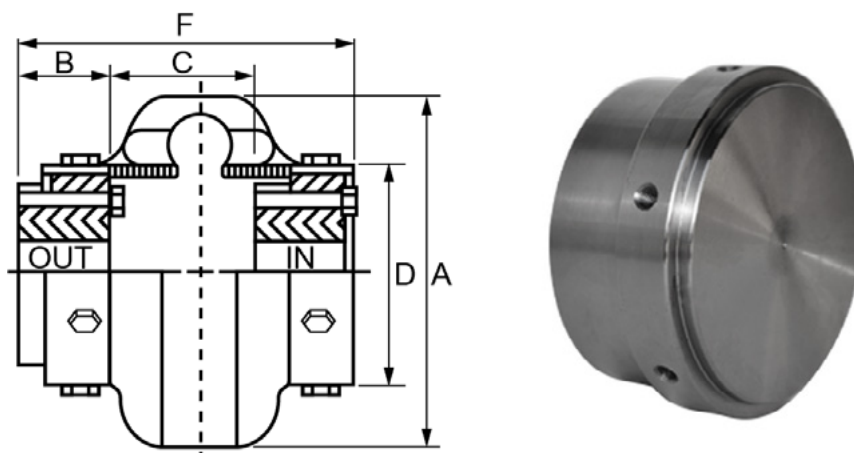

Dynamic Coupling No.	QD Bush No.	Torque (kgf.m)	Max. Bore (mm)	Max. rpm	Power Rating (kW/rpm)	Dimensions (mm)							Weight (kg)
						A Outer Diameter	B Hub Length	C		D Hub Diameter	Total Length		
								Min. Shaft Spacing	Max. Shaft Spacing		E In	F Out	
D-4	JA	6.4	30	7500	0.0066	116	25	31	48	66	82	99	0.95
D-5	SH	11.0	35	7500	0.01100	137	32	44	48	80	108	114	1.63
D-10	SDS	16.7	42	7200	0.0170	162	33	30	59	93	97	125	2.18
D-20	SK	26.7	55	6600	0.0270	184	48	16	67	114	108	162	3.86
D-30	SF	42.1	60	5800	0.0430	210	51	37	56	138	138	157	6.35
D-40	E	63.4	75	5000	0.0660	241	67	32	44	168	165	178	10.80
D-50	E	88.2	75	4200	0.0900	279	67	35	73	207	168	207	17.06
D-60	F	144.0	90	3800	0.1480	318	92	38	48	222	222	232	20.64
D-70	J	254.0	100	3600	0.2620	356	114	33	36	235	262	265	30.89
D-80	M	455.0	140	2000	0.4670	406	171	19	32	286	362	375	63.50
D-100*	M	980.0	140	1900	1.0000	533	173	44	29	359	390	375	113.40
D-120*	N	1961.0	150	1800	2.0000	635	206	44	29	448	456	441	215.46

All dimensions are in mm unless otherwise stated.

## Dynamic® Couplings with Taper-Lock Hubs

Taper-Lock Hubs offer secure and efficient shaft attachment with a precise taper-lock design for easy installation and removal. Made from high-strength materials, these hubs ensure reliable performance and durability.

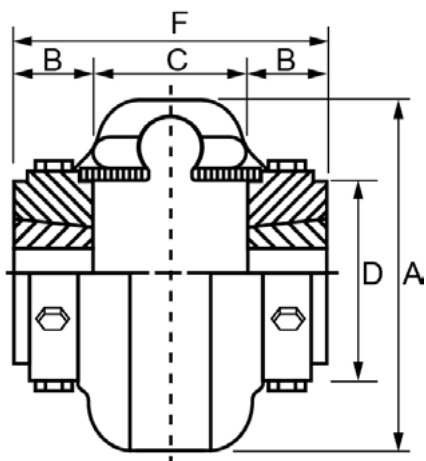

Dynamic Coupling No.	Taper Lock Bush No.	Torque (kgf.m)	Max. Bore (mm)	Max. rpm	Power Rating (kW/rpm)	Dimensions (mm)						Weight (kg)	
						A Outer Diameter	B Hub Length	C		D Hub Diameter	Total Length		
								In	Out		E In		F Out
D-3	1008	4.2	25	7500	0.0043	102	22	43.0	-	59	87	-	0.82
D-4	1008	6.4	25	7500	0.0066	116	22	43.0	-	66	87	-	1.18
D-5	1108	11.0	28	7500	0.0110	137	22	56.0	-	80	100	-	1.81
D-10	1610	16.7	35	7500	0.0170	162	25	52.0	-	93	103	-	2.72
D-20	1610	26.7	42	6600	0.0270	184	25	63.5	-	114	114	-	4.08
D-30	2012	42.1	50	5800	0.0430	210	32	65.0	-	138	129	-	6.17
D-40	2517	63.4	65	5000	0.0660	241	44	60.0	-	168	149	-	9.89
D-50	2517	88.2	65	4200	0.0900	279	44	76.0	-	207	165	-	14.29
D-60	3020	144.0	75	3800	0.1480	318	51	84.0	-	222	186	-	21.14
D-70	3535	254.0	100	3600	0.2620	356	89	60.0	-	235	238	-	30.25
D-80	4040	455.0	100	2000	0.4670	406	102	95.0	-	286	298	-	37.19
D-100	4545	980.0	110	1900	1.0000	533	114	38	152	359	267	381	113.40
D-120	5050	1961	125	1800	2000	635	127	51	181	448	305	435	185.07

All dimensions are in mm unless otherwise stated.

## Dynamic® Spacer Couplings

The Max Dynamic Polyurethane Spacer is engineered for exceptional durability and performance in demanding applications. Its high-quality polyurethane construction ensures superior resilience and flexibility, providing reliable vibration damping and load distribution. Ideal for various industrial uses, this spacer enhances equipment longevity, operational efficiency, and simplifies maintenance, making it an indispensable component for your machinery.

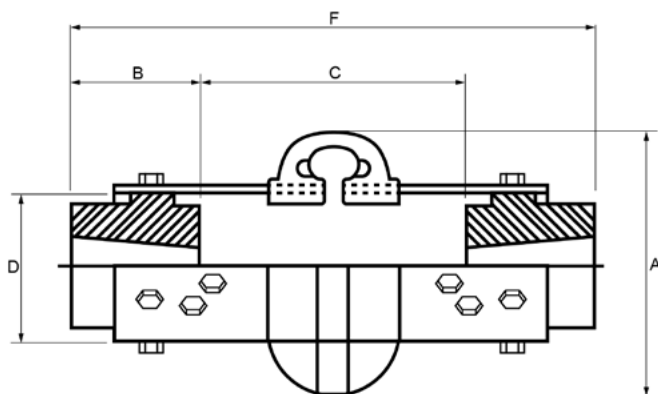

Dynamic Coupling No.	Torque (kgf.m)	Max. Bore (mm)	Max. rpm	Power Rating (kW/ rpm)	Dimensions						
					A Outer Diameter	B Hub Length	C		D Hub Diameter	Total Length	
							Min. Shaft Spacing	Max. Shaft Spacing		E In	F Out
DS-2	2.20	28	7500	0.0023	89	24	91	100	47	146	149
D-3	4.20	34	7500	0.0043	102	32	85	140	59	184	216
D-4	6.40	42	7500	0.0066	116	37	89	140	66	184	216
D-5	11.00	48	7500	0.0110	137	45	89	140	80	184	216
D-10	16.70	55	7500	0.0170	162	45	89	140	93	184	228
D-20	26.70	65	6600	0.0270	184	50	67	180	114	238	280
D-30	42.10	75	5800	0.0430	210	56	54	180	138	238	293
D-40	63.40	85	5000	0.0660	241	61	41	180	168	238	307
D-50	88.20	90	4200	0.0900	249	69	28	180	207	238	319
D-60	144.00	105	3800	0.1480	318	80	66	250	222	318	415
D-70	254.00	120	3600	0.2620	356	85	59	250	235	318	421
D-80	455.00	155	2000	0.4670	406	114	37	250	286	318	478

All dimensions are in mm unless otherwise stated.

## Recommended Capscrew

Size	Torque (kgf.m)
D-2, D-3, D-4, D-5, D-10	2.3
D-20, D-30, D-40, D-50	4.1
D-60, D-70, D-80	10.2
D-100, D-120	37.7

### Note:

1. A bolt having the highest tension shall be used
2. Adhesive shall be used
3. Never use a bolt more than twice.

The elastomeric design of the TransDrive flexible tyre coupling provides exceptional vibration and shock absorbing capabilities. It compensates for significant parallel and angular misalignment, resulting in a substantial reduction of load on machinery and bearings, ensuring smoother operation and prolonged equipment life.

They can be easily integrated into existing systems and used in conjunction with spacers for convenient access for installation and maintenance.

The TransDrive tyre coupling is fully interchangeable with leading European and American brands, offering versatility and flexibility.



## Power Ratings

Ratings	F40	F50	F60	F70	F80	F90	F100	F110	F120	F140	F160	F180	F200	F220
Power kW per 100 rpm	0.251	0.691	1.33	2.62	3.93	5.24	7.07	9.16	13.9	24.3	39.5	65.7	96.7	121
Power kW @ 720 rpm	1.81	4.98	9.57	18.8	28.3	37.7	50.9	66.0	100	175	284	473	703	875
Power kW @ 960 rpm	2.41	6.63	12.8	25.1	37.7	50.3	67.9	88.0	134	234	379	630	937	1166
Power kW @ 1440 rpm	3.62	9.95	19.1	37.7	56.5	75.4	102	132	201	351	568	945	-	-
Power kW @ 2880 rpm	7.24	19.9	38.3	75.4	113	151	-	-	-	-	-	-	-	-
Speed Maximum (rpm)	4500	4500	4000	3600	3100	3000	2600	2300	2050	1800	1600	1500	1300	1100
Torque Nominal (Nm)	24	66	127	250	375	500	675	875	1330	2325	3770	6270	9325	11600
Torque Maximum (Nm)	64	160	318	487	759	1096	1517	2137	3547	5642	9339	16455	23508	33125

## Physical Characteristics

Size	Max. Speed rev/min	Nominal Torque Nm TK N	Max. Torque Nm TK MAX	Torsional Stiffness Nm/O	Max. parallel misalignment mm	Max. end float mm ±	Approx. mass kg	Alternating Torque ± Nm @ 10Hz TKW	Resonance Factor V R	Dampening Coefficient
F40	4500	24	64	5	1.1	1.3	0.1	11	7	0.9
F50	4500	66	160	13	1.3	1.7	0.3	26	7	0.9
F60	4000	127	318	26	1.6	2	0.5	53	7	0.9
F70	3600	250	487	41	1.9	2.3	0.7	81	7	0.9
F80	3100	375	759	63	2.1	2.6	1	127	7	0.9
F90	3000	500	109	91	2.4	3	1.1	183	7	0.9
F100	2600	675	1517	126	2.6	3.3	1.1	252	7	0.9
F110	2300	875	2137	178	2.9	3.7	1.4	356	7	0.9
F120	2050	1330	3547	296	3.2	4	2.3	591	7	0.9
F140	1800	2325	5642	470	3.7	4.6	2.6	940	7	0.9
F160	1600	3770	9339	778	4.32	5.3	3.4	1556	7	0.9
F180	1500	6270	16455	1371	4.8	6	7.7	2742	7	0.9
F200	1300	9325	23508	1959	5.3	6.6	8.0	3918	7	0.9
F220	1100	11600	33125	2760	5.8	7.3	10.0	5521	7	0.9



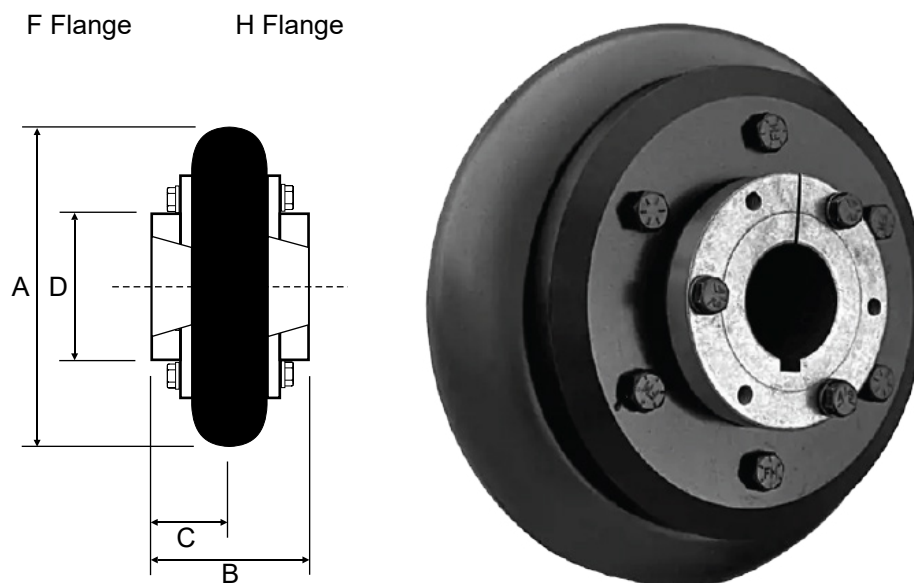

Part No.	Bore		Bush		Weight (kg)		Outside Diameter A	Length B	Length Through Bore C	D
	Min	Max	F	H	F	H				
F40	10.0	25.0	1008	1008	0.8	0.8	104	66.0	22.2	-
F50	11.0	32.0	1210	1210	1.2	1.2	133	75.0	32.0	79.0
F60	14.0	42.0	1610	1610	2.0	2.0	165	83.0	38.2	103.0
F70	14.0	50.0	1610	1610	3.1	3.0	187	100.0	30.4	80.0
F80	14.0	65.0	2012	2012	4.9	4.6	211	107.0	42.0	98.0
F90	16.0	65.0	2517	2517	7.0	7.0	235	136.0	48.5	108.0
F100	16.0	75.0	2517	3020	9.9	9.4	254	138.0	55.8	120.0
F110	24.0	75.0	2517	3020	11.7	11.7	279	135.0	68.0	134.0
F120	24.0	100.0	3020	3525	16.5	16.9	314	151.0	70.1	140.0
F140	35.0	100.0	3525	3525	22.3	22.3	359	203.0	93.6	147.0
F160	40.0	115.0	4030	4030	32.5	32.5	402	226.0	101.6	197.0
F180	55.0	125.0	4535	4535	42.2	42.2	470	261.0	114.3	205.0
F200	55.0	125.0	4535	4535	72.0	72.0	562	264.0	114.3	223.0
F220	55.0	125.0	5040	5040	72.0	72.0	474	302.0	127.0	118.0

## Alignment

	F40	F50	F60	F70	F80	F90	F100	F110	F120	F140	F160	F180	F200	F220
Max. Parallel	1.1	1.3	1.6	1.9	2.1	2.4	2.6	2.9	3.2	3.7	4.2	4.8	5.3	6.0
Max. Axial	±1.3	±1.7	±2.0	±2.3	±2.6	±3.0	±3.3	±3.7	±4.0	±4.6	±5.3	±6.0	±6.4	±7.0
Max. Angular	4	4	4	4	4	4	4	4	4	4	4	4	4	4

# Mechanical Flexing Couplings

Mechanical flexing couplings rely on the flexibility of the mechanical components, such as gears, chains, and grid, to provide misalignment compensation. These types of couplings are generally more robust than elastomeric and suitable for high torque applications.

## Our range

- ▶ Chain Couplings
- ▶ Curved Tooth Gear Couplings
- ▶ Gear Couplings
- ▶ Grid Couplings



The chain coupling is composed of double-strand roller chain and two sprockets, featuring a simple and compact structure that offers a high flexibility and greater transmission capacity compared to similar sized coupling.

The chain coupling allows simple connection and disconnection, and use of the housing enhances safety and durability.



## Service Factors

Operating Conditions	Operating hours/day			
	Hours Per Day Duty		Hours Per Day Duty	
Small load variations, small impact, light road, no reversing	1.0	1.5	2	2.5
Medium load variations, medium impact, no reversing (normally)	1.5	2	2.5	3
Large load variations, large impact, reversing while loaded	2.0	2.5	3	3.5
Type of prime mover	Motor, turbine		Combustion engine	

In case of 16 operating hours/day or longer, add 1.0 to service factor in the case of 8 operating hours/day, provided that service factor for 8 operating hours/day is applicable when speed is 50rpm or less.

## Components



### Straight Bore Sprockets & Duplex Roller Chains

The coupling includes a pair of sprockets, one for each shaft being connected. Chain couplings also include Duplex Roller Chains, which are used to connect the two sprockets.

Part Number	Max RPM	
	Without Cover	With Cover
CC4012	875	5000
CC4016		
CC5016	800	4000
CC5018		
CC6018	675	3000
CC6022		
CC8018	500	2000
CC8022		
CC10020	450	1800
CC12022		



### Chain Coupling Cover

Made of durable materials like metal or high-strength plastics to withstand the operating conditions of the machinery. They are designed to be easily removable for maintenance and inspection purposes while providing effective protection during normal operation. The cover will also commonly include, connecting pins and a locking arrangement.

Part Number	For RPM Exceeding
CC4012-COV	875
CC4016-COV	
CC5016-COV	800
CC5018-COV	
CC6018-COV	675
CC6022-COV	
CC8018-COV	500
CC8022-COV	
CC10020-COV	450

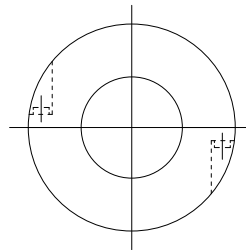
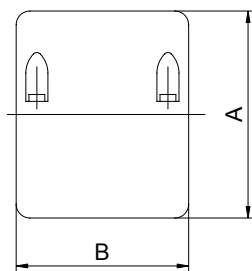
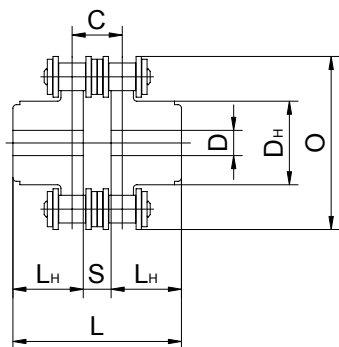

Chain Coupling Number	Chain Pitch	Coupling										Casting		
		Drill hole	Shaft diam.		O	L	D <sub>H</sub>	L <sub>H</sub>	S	C	Approx. weight (kg/m)	A	B	Approx. weight (kg/m)
			Min.	Max.										
CC3012	9.525	12	13.5	16	45	65	27.2	29.5	6	10.1	0.31	69	63	0.22
CC4012	12.70	12	14	22	62	79.4	36	36	7.4	14.4	0.73	77	72	0.3
CC4014		12	14	28	69	79.4	45	36			1.12	84	75	0.31
CC4016		13.5	16	32	77	87.4	51.5	40			1.5	92	72	0.35
CC5014	15.875	14.5	17	35	86	99.7	56	45	9.7	18.1	2.15	101	85	0.47
CC5016		14.5	18	40	96	99.7	64	45			2.75	110	87	0.5
CC5018		16	18	45	106	99.7	73.5	45			3.6	122	85	0.6
CC6018	19.05	20	22	56	127	123.5	89.5	56	11.5	22.8	6.55	147	105	1.2
CC6020		20	24	60	139	123.5	102.5	56			8.38	158	105	1.2
CC6022		20	28	71	151	123.5	115	56			10.4	168	117	1.2
CC8018	20.40	20	32	80	169	141.2	115	63	15.2	29.3	13.2	190	129	1.9
CC8020		20	36	90	185	145.2	125	65			16.2	210	137	2.5
CC8022		20	40	100	202	157.2	142	71			21.8	226	137	2.7
CC10020	31.75	25	45	110	233	178.8	162	80	18.8	35.8	32.4	281	153	4.1
CC12018	38.10	35	50	125	256	202.7	173	90	22.7	45.4	43.2	307	181	5.2
CC12022		35	56	140	304	222.7	213	100			69.1	357	181	6.7

All dimensions are in mm unless otherwise stated.

The first two or three digits of chain coupling No. imply chain No. and the two succeeding digits imply the No. of teeth.

For increased safety, Chain Coupling covers should be used. The cover not only improves the safety of the workplace, but also increases the Chain Couplings overall durability.

## Power Transmission Capacity

No.	Max. shaft diam. (mm)	Allowable transmission torque at 50rpm or less (kgf . m)	Coupling Speed (rpm)														
			1	5	10	25	50	100	200	300	400	500	600	800	1000	1200	1500
CC3012	16	10.2	0.01	0.05	0.11	0.26	0.52	0.79	1.21	1.58	1.89	2.26	2.58	3.19	3.88	4.41	5.35
CC4012	22	22.2	0.02	0.11	0.22	0.58	1.15	1.73	2.63	3.46	4.15	4.96	5.67	7.01	8.53	9.68	11.6
CC4014	28	30.2	0.03	0.16	0.32	0.79	1.58	2.36	3.59	4.72	5.66	6.77	7.72	9.56	11.6	13.2	15.8
CC4016	32	39.4	0.04	0.21	0.41	1.03	2.06	3.09	4.69	6.17	7.41	8.85	10.1	12.5	15.3	17.3	21.0
CC5014	35	57.4	0.06	0.30	0.60	1.50	3.00	4.48	6.80	8.95	10.70	12.80	14.7	18.1	22.1	25.1	30.0
CC5016	40	75.0	0.08	0.39	0.78	1.95	3.91	5.86	8.92	11.7	14.1	16.8	19.2	23.8	28.9	32.9	39.9
CC5018	45	95.0	0.10	0.50	0.99	2.48	4.95	7.43	11.3	14.9	17.8	21.3	24.4	30.1	36.6	41.6	50.5
CC6018	56	179	0.18	0.93	1.87	4.67	9.33	14.0	21.3	28.0	33.6	40.1	45.9	56.8	69.1	78.4	95.2
CC6022	71	242	0.25	1.25	2.51	6.31	12.5	18.8	28.6	37.7	45.3	54.1	61.9	76.5	93.1	105	128
CC8018	80	396	0.41	2.07	4.14	10.3	20.7	31.0	47.2	62.1	74.5	89.0	101	126	153	174	211
CC8022	100	570	0.59	2.96	5.93	14.8	29.6	44.5	67.2	89.0	106	126	153	174	211	246	265
CC10020	110	896	0.93	4.66	9.33	23.3	46.6	70.0	106	140	168	200	229	283	345	392	476
CC12018	125	1350	1.40	7.02	14.0	35.1	70.2	105	160	210	252	302	345	426	519	590	716
CC12022	140	1750	1.81	9.07	18.1	45.3	90.7	136	206	272	326	390	446	551	671	762	
Lubricated Method			A					B			C						

No.	Max. shaft diam. (mm)	Allowable transmission torque at 50rpm or less (kgf . m)	Coupling Speed (rpm)								
			1800	2000	2500	3000	3600	4000	4800	5200	6000
CC3012	16	10.2	6.25	6.73	8.12	9.44	11.0	12.0	14.0	14.8	16.7
CC4012	22	22.2	13.7	14.8	17.9	20.7	24.1	26.3	30.08		
CC4014	28	30.2	18.7	20.2	24.4	28.3	32.9	35.9	42.1		
CC4016	32	39.4	24.4	26.3	31.9	37.0	43.0	46.9	54.9		
CC5014	35	57.4	35.4	38.3	46.2	53.6	62.4				
CC5016	40	75.0	46.4	50.0	60.6	70.4	81.6				
CC5018	45	95.0	58.8	63.4	76.8	89.2					
CC6018	56	179	111	120	145						
CC6022	71	242	149	161	195						
CC8018	80	396	246	265							
CC8022	100	570	352	379							
CC10020	110	896	554								
Lubricated Method			C								

Be sure to use the casing with the coupling in the case of lubricant type C. For details of lubrication types A and B, refer to "Lubrication" section on the next page.

## Lubrication

There are three methods to lubricate chain couplings, according to operating speed (see Power Transmission Capacity table on page 31):

1. Greasing Monthly
2. Greasing Weekly or fill grease in the attached casing.
3. Fill grease in the attached casing.

### Note

When attaching the casing, use high-quality grease because the grease is pressed to the inside wall of the casing due to centrifugal force, deteriorating lubricating ability of the grease. It is recommended to change the grease periodically to maintain high performance and durability of the coupling.

Grease change intervals (with casing attached)		
Operating conditions	First change	2nd and later changes
Operating at 1/2 max speed or higher	1000 hours	2000 hours
Operating at 1/2 max speed or lower	2000 hours	4000 hours

Allowable errors

$x = 2\%$  or less of pitch of roller chain used

$n = 1$  or less

In case of high speed operation, shaft deviation and misalignment must be 1/2 allowable errors.

Grease change intervals (with casing attached)			
Chain coupling No.	Filing quantity (kg)	Chain coupling No.	Filing quantity (kg)
CC3012	0.08	6020	0.44
CC4012	0.12	6022	0.48
CC4014	0.16	8018	0.79
CC4016	0.17	8020	0.86
CC5014	0.24	8022	1.00
CC5016	0.25	10020	1.70
CC5018	0.26	12018	3.50
CC6018	0.42	12022	4.50

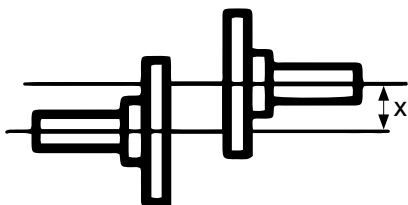

Parallel

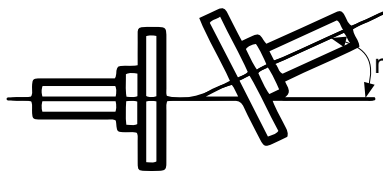

Angular

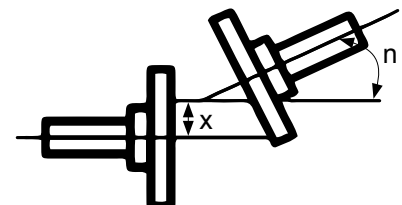

Combined

# Curved Tooth Gear Couplings

## Product Characteristics

- ▶ Double Section type curved-tooth gear coupling
- ▶ Widely applicable in various mechanical & hydraulic fields
- ▶ Nylon and steel matched, maintenance free
- ▶ Able to offset axial, radial and angular misalignments
- ▶ Axial plugging assembly, very convenient

## Nylon Toothed Sleeve Characteristics

- ▶ Excellent mechanical performance
- ▶ High rigidity
- ▶ High temperature resistance (+100°C)
- ▶ Not embrittled at low temperature
- ▶ Good slippery and frictional behaviour
- ▶ Excellent electrical insulation behaviour
- ▶ Chemical corrosion endurable
- ▶ High accuracy of processing

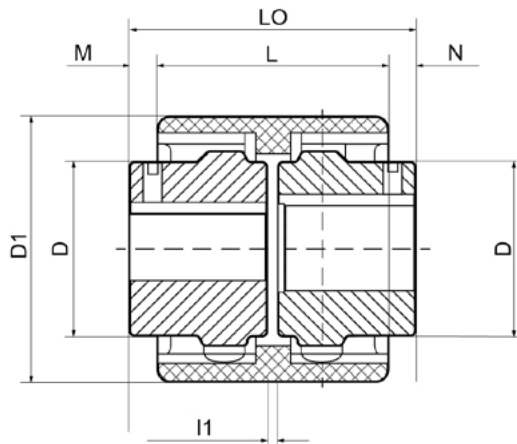

Size	Max Bore (mm)	Dimensions							Torque Rating (Nm)	Weight (kg)	
		I1 I2	LO	L	M,N	E	D1	D		Nylon Sleeve	Hub Half
RGF-19	19	25	54	37	8.5	4	48	30	16	0.03	0.21
RGF-24	24	26	56	41	7.5	4	52	36	20	0.04	0.25
RGF-28	28	40	84	46	19	4	66	28	45	0.07	0.62
RGF-32	32	40	84	48	18	4	76	50	60	0.09	0.83
RGF-38	38	40	84	48	18	4	83	58	80	0.11	1.04
RGF-42	42	42	88	50	19	4	92	65	100	0.14	1.41
RGF-48	48	50	104	50	27	4	95	67	140	0.16	1.43
RGF-55	55	52	108	58	25	4	114	82	240	0.26	2.50
RGF-65	65	55	114	65	23	4	132	95	380	0.39	3.58

All dimensions are in mm unless otherwise stated

### Selection of Method size

By using the following formula, obtain Design Torque required.

$$T = 97400 \frac{\text{kW}}{N} \times \text{S.F.} \qquad T = 71620 \frac{\text{HP}}{N} \times \text{S.F.}$$

T = Design torque (kg cm) kW = Power (kilo Watts)

HP = Horse Power

N = Working revolution (rpm)

SF = Recommended service factor

Select the size with the same or with the greater value at the Basic Torque column. Refer to the maximum shaft diameters of the size selected, and then compare the shaft diameters of the application with the maximum bore diameter of the size selected. If the coupling bore is not suitable, select the larger size coupling.

### Special requirements

- ▶ On calculating the torque required, use the lowest operating speed (N) of the application
- ▶ If there are reverse motions repeated or frequent irregular kind changes, take service factor twice

### Example

When you select a coupling to connects 30HP, 1,1750rpm motor and rotary type pump. Motor shaft diameter is 48mm and pump's 52mm.

- ▶ Service factor of pump is 1.8
- ▶ Normal transmitting power is 30HP

$$\text{Torque (kg cm)} = \frac{30 \times 71.620 \times 1.8}{1.750} = 2.210$$

The coupling size 1040 accepts the calculated torque 2210 and then compare the application shaft diameter sizes(52mm) to the maximum bore of the selected coupling size 1040(43 mm).

You will select the coupling size 1060 accepting up to 55mm shaft diameter. The size also accepts the application motor speed 1750 rpm. Either H (Horizontal split aluminum) or V (Vertical split steel) cover is available. Finally, the coupling size 1060 is selected.



KCP Gear Couplings serve as a mechanical device which connect the shafts of two distinct machines and can accommodate large axial moments as well as small amounts of shaft misalignment.

Commercial Gear Couplings transmit more torque than other types of couplings of similar physical size. Because of this superior load transmitting capability, Gear Couplings have become widely used for higher speed applications, as well as for applications that require a combination of high torque capacity and a low inertia of the drive system.

Gear Couplings are torsionally rigid and couple two designs, one of which is completely flexible and one of which is rigid. Gear Couplings consist of two shaft hubs with external teeth, which are then connected by means of a sleeve, usually two pieces, containing internal teeth. A flexible spline with the hubs and sleeves rotating together is the working action of a Gear Coupling. The proper type of lubrication, applied frequently and adequately, is essential for the successful operation of this system.

This coupling is made up of one flexible geared half and on rigid half. A flexible & rigid coupling such as this is primarily used for "floating shaft" applications. The coupling accommodates angular misalignment but does not accommodate parallel displacement of shafts.



## G20 Type - Large

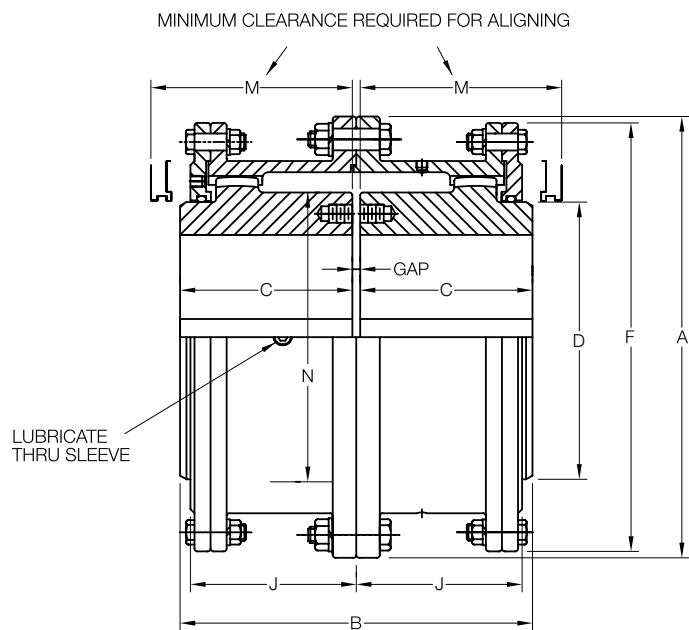

Size	Torque Rating (Nm)	Allow Speed rpm	Max Bore (mm)	Min Bore (mm)	Cplg Weight G20 (kg)	Lube Weight (kg)	A	B	C	D	F	H	J	M	Gap
1080	170,000	1,750	266	101.60	703	9.5	590.6	508.5	249.2	355.6	571.5	242.8	300.0	368.3	10
1090	226,000	1,550	290	114.30	984	12.2	660.4	565.4	276.4	393.7	641.4	265.2	327.2	419.1	13
1100	310,000	1,450	320	127.00	1,302	15.0	711.2	622.3	304.8	444.5	698.5	293.6	355.6	469.9	13
1110	413,000	1,330	373	139.70	1,678	17.7	774.7	679.2	333.2	495.3	479.3	322.3	384.0	520.7	13
1120	555,000	1,200	400	152.40	2,114	20.9	838.2	717.8	352.6	546.1	825.5	341.4	403.4	571.5	13
1130	719,000	1,075	440	165.10	2,595	32.7	911.4	761.7	371.3	584.2	886	362.0	434.8	609.6	19
1140	911,000	920	460.0	177.80	3,107	33.1	965.2	806.4	393.2	635.0	939.8	378.0	457.2	660.4	19
1150	1,100,000	770	490.0	190.50	3,765	40.8	1,028.7	857.2	419.1	685.8	1,003.3	407.9	482.6	711.2	19
1160	1,310,000	650	525	254.00	4,708	43.1	1,111.2	908.0	441.3	736.6	1,085.9	419.1	504.6	762	25
1180	1,660,000	480	600	285.75	6,260	49.9	1,219.2	939.8	457.2	838.2	1,193.8	434.8	520.7	863.6	25
1200	2,140,000	370	660	317.50	8,582	68.0	1,358.9	1,098.60	536.6	927.1	1,308.1	514.4	635.0	965.2	25
1220	2,720,000	290	725	349.25	11,685	107.0	1,511.3	<b>1,193.80</b>	584.2	1,016.0	1,473.2	565.2	685.8	1,066.8	25

\* Coupling Weight is without Bore Machining. Measurements in millimetres.

## G20 Type - Standard

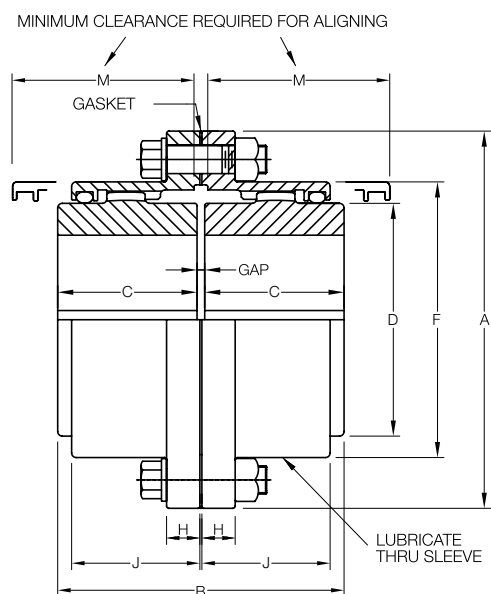

Size	Torque Rating (Nm)	Allow Speed rpm	Max Bore (mm)	Min Bore (mm)	Cplg Weight G20 (kg)	Lube Weight (kg)	A	B	C	D	F	H	J	M	Gap
1010	1,140	8,000	50	13	4.54	0.0408	115.9	88.9	42.9	68.6	83.8	14.0	38.9	51	3
1015	2,350	6,500	65	20	9.07	0.0726	152.4	101.6	49.3	86.4	105.2	19.0	47.8	61	3
1020	4,270	5,600	78	26	15.90	0.1130	177.8	127.0	62.0	105.2	126.5	19.0	59.4	77	3
1025	7,470	5,000	98	32	29.50	0.2127	212.7	158.9	77.0	130.6	154.9	21.8	71.6	92	5
1030	12,100	4,400	111	39	43.10	0.3630	239.7	187.4	91.2	152.4	180.3	21.8	83.8	107	5
1035	18,500	3,900	134	51	68.00	0.5440	279.4	218.9	106.4	177.8	211.3	28.4	97.5	130	6
1040	30,600	3,600	160	64	97.50	0.9070	317.5	247.3	120.6	209.6	245.4	28.4	111.3	145	6
1045	42,000	3,200	183	77	136.00	1.0400	346.1	277.7	134.9	235.0	274.1	28.4	122.9	166	8
1050	56,600	2,900	200	89	191.00	1.7700	388.9	314.3	153.2	254.0	305.8	38.1	140.7	183	8
1055	74,000	2,650	220	102	249.00	2.2200	425.4	344.3	168.1	279.4	334.3	38.1	158.0	204	8
1060	90,400	2,450	244	115	306.00	3.1800	457.2	384.4	188.2	304.8	366.0	25.4	169.2	229	8
1070	135,000	2,150	289	127	485.00	4.3500	527.0	<b>451.5</b>	220.7	355.6	424.9	28.4	195.6	267	10

\* Coupling Weight is without Bore Machining. Measurements in millimetres.

## Lubrication & Handling

### Lubricant

- ▶ Grease the Internal gear teeth and crown gear teeth and fill enough lubricant Grease.
- ▶ Supplement and Replacement: Add grease every month or every 240-250 hours operating. Renew all the contaminated grease every 3 month or every 4000 hours operating
- ▶ Selection: Allowable temperature of grease is from 17°C to 70°C. Refer to the table under Selection of Lubricant that shows the coupling RPM allowed fix the listed grease.

Company/Oil	Grease # 1	Grease # 0
Gulf Oil Corp.	Gulfcrown Grease EP #1	Gulfcrown Grease EP #0
Shell Oil Corp.	Alvanvia Grease EP #1	Alvania Grease EP-RO
Texaco Inc.	Multifak EP - 1	Multifak EP - 0
Mobil Oil Corp.	Mobilux EP - 1	Mobilux EP - 0

Note: Lubricants listed in this manual are typical products.

### Lubricant Filming

- ▶ Place the Lube plug holes 2EA horizontal level.  
Fill up Lubricant until it overflows from the opposite hole.
- ▶ Supplement every month, or 240-250 hours operating.
- ▶ Replace completely all the contaminated lubricant, every 3 months or every 4,000 hours operating.

## Selection of Lubricant

CST <40°C	CST >40°C	Shell	Mobil	Michang	Buhmwoo	Gulf	Fujkosan Nipponkoju	Houghton	Hanil	Caltex	
68	315	omala 68	Mobilgear 626	Pio Gear EP 68	Buhmwoo Gearlube BG-68	Gulf EP Lubricant R 68	Hirax ME GO 300	MP Gear Oil 68	Nico Gear SP 68	Daphne CE compound 68C	Meropa Lubricant 68
100	465	omala 68		Pio Gear EP 68	Buhmwoo Gearlube BG-100	Gulf EP Lubricant HD 100	Hirax ME GO 500	MP Gear Oil 100	Nico Gear SP 100	Daphne CE compound 100S	Meropa Lubricant 100
150	700	omala 150	Mobilgear 629	Pio Gear EP 150	Buhmwoo Gearlube BG-150	Gulf EP Lubricant R 150, HD 100	Hirax ME GO 700	MP Gear Oil 150	Nico Gear SP 150	Daphne CE compound 150S	Meropa Lubricant 150 Synthetic Gear Lube
150	700	omala 220	Mobilgear 630	Pio Gear EP 220	Buhmwoo Gearlube BG-220	Gulf EP Lubricant R 220, HD 220	Hirax ME GO 1000	MP Gear Oil 220	Nico Gear SP 220	Daphne CE compound 220S	Meropa Lubricant 220
320	1500	omala 320	Mobilgear 632	Pio Gear EP 320	Buhmwoo Gearlube BG-320	Gulf EP Lubricant R 320, HD 320	Hirax ME GO 1500	MP Gear Oil 320	Nico Gear SP 320	Daphne CE compound 320S	Meropa Lubricant 320

Gear coupling lubricant selection chart.

## Installation

KCP Gear Couplings are designed to provide a mechanical connection between the rotating shafts of mechanical equipment, using gear mesh accommodate inherent misalignment while transmitting the power and torque between the connected shaft.

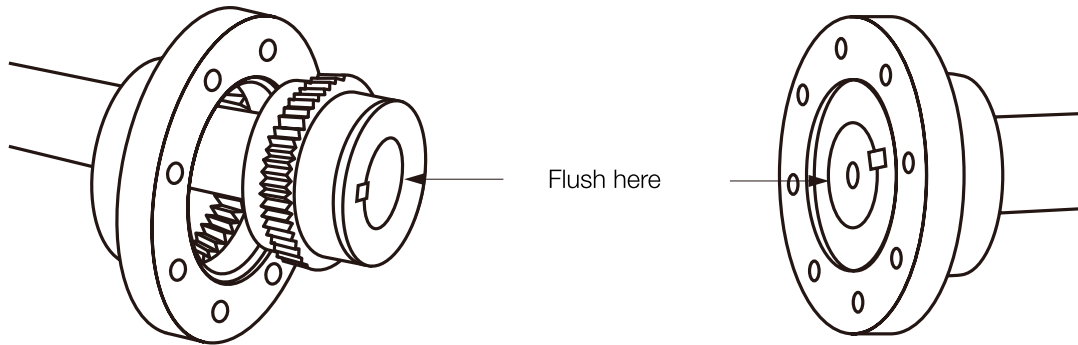

### 1. Mount Flanged Sleeves, Seals and Hub

- ▶ Examine the coupling assembly to insure there is no visible damage.
- ▶ Clean the hub bores and shafts using lint free cloth. Remove any nicks or burrs.
- ▶ When assembled, the keys should have a close side to side fit in the keyways in the hub and shaft with a slight clearance over the top of the keys.
- ▶ Place the flanged sleeves with oil rings on shafts before mounting flex hubs.

### 3. Straight Bore with interference Fit

- ▶ Accurately measure the bore and shaft diameters to assure proper fit.
- ▶ Install the keys in the shaft.
- ▶ heat the hub (135°C) in an oven until the bore is efficiently larger than the shaft.
- ▶ When the hub expanded, install it on the shaft to the desired axial position.

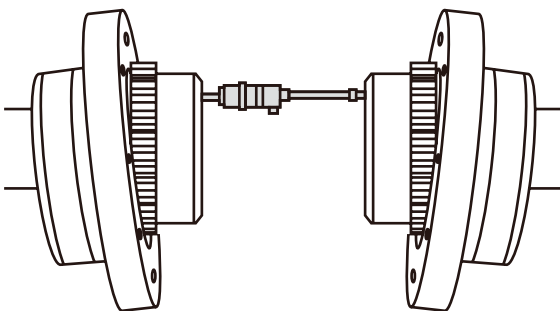

### 2. Straight Bore with Clearance / Slip Fit

- ▶ Install the keys in the shaft.
- ▶ Check to be sure that the set screws in the hub do not protrude into the keyway or the bore. Remove or back out the set screw to provide clearance during assembly.
- ▶ Slide the hub up the shaft to the desired axial position.
- ▶ Assemble and tighten the set screws using a calibrated torque wrench.

### 4. Taper Bore

- ▶ Check for acceptable contact pattern between the hub and the shaft.
- ▶ Put the hub on the shaft, keeping the keyways aligned.
- ▶ Lightly tap the face of the hub with a soft mallet. The resultant position will provide a starting point for the hub axial draw up.
- ▶ Use a depth micrometer to measure the distance from the shaft end to the hub face, and record the dimension.
- ▶ Mount a dial indicator to read axial hub advancement. Alternatively, the indicator can be positioned to contact the end of the hub.
- ▶ Remove the hub and install the keys in the shaft.
- ▶ Heat the hub (177°C) in an oven until the bore is sufficiently larger than the shaft. Do not exceed 260°C.
- ▶ When the hub expanded, install it quickly on the shaft to the "zero" set point. Continue to advance the hub up the taper to the desired axial position.

### 5. Shaft Alignment

- ▶ Use an inside micrometer or a spacer bar equal in thickness and at 90° intervals to measure the distance between hubs to gap.
- ▶ The "Angular Misalignment" value is the maximum difference between the measurements X and Y taken at opposite ends of the flanges.

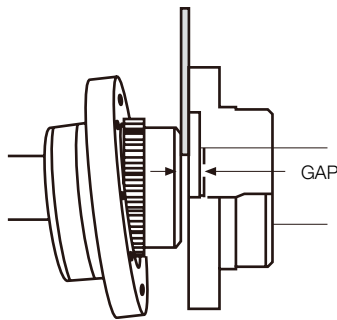
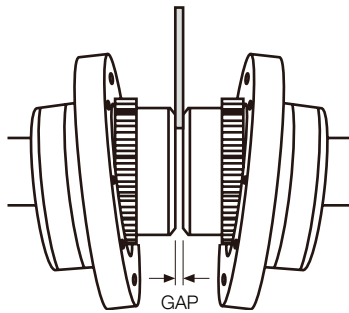

### 6. Sleeve Installation

- ▶ Insert gasket between flanges and gap disc into counter bore of each rigid hub for floating shaft assemblies, and bolt flanges together.
- ▶ Check the alignment of the coupling. Determine "W" by measuring distances "W"max and "W"min between flex hub and sleeve using a depth micrometer or feeler gauges. The difference between "W"max and "W"min must not exceed the "W" value.

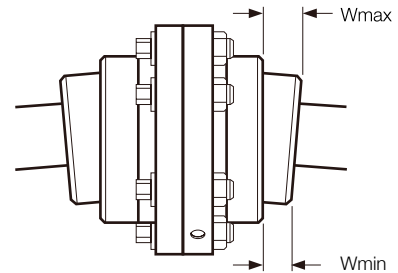
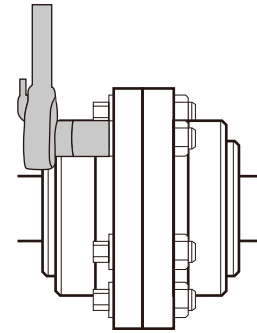

### Annual Maintenance

1. Check alignment. If the maximum operating misalignment values are exceeded, realign the coupling.
2. Inspect oil-ring and gasket to determine if replacement is required.
3. Re-lubricate coupling if using general purpose grease until an excess appears at an open hole.

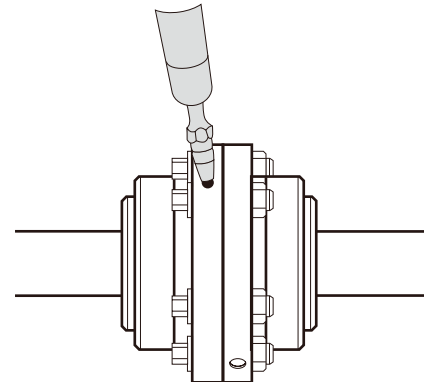

## Alignment Data

To improve the service life of the coupling, shafts should be aligned to minimize deflection of the flexing elements. Shaft alignment is required in the axial, parallel, and angular directions, with each of these values not to exceed the recommended installation limits. Shaft alignment can be measured using various established methods, including Laser Alignment, Reverse Dial Indicator, and Rim and Face.

### Parallel Misalignment

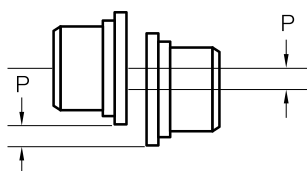

### Angular Misalignment

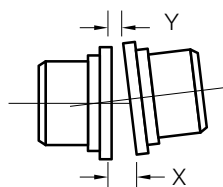

Size	Recommended Installation		Operating		Fastener Tightening Torque Values (Nm)
	Parallel Offset-P Max (mm)	Angular (X-Y) Max (mm)	Parallel Offset-P Max (mm)	Angular (X-Y) Max (mm)	
1010G	0.05	0.15	0.66	1.80	12
1020G	0.08	0.23	1.02	2.74	102
1030G	0.13	0.33	1.52	3.99	203
1040G	0.18	0.46	2.13	5.49	339
1050G	0.23	0.56	2.72	6.65	339
1060G	0.28	0.66	3.35	9.98	339
1080G	0.41	0.81	2.46	4.83	-
1100G	0.48	1.02	2.97	6.15	-
1120G	0.58	1.24	3.51	7.49	-
1140G	0.64	1.45	3.81	8.64	-
1045G	0.20	0.51	2.39	6.15	339
1055G	0.28	0.61	3.12	7.32	339
1070G	0.33	0.79	3.94	9.32	339
1090G	0.43	0.91	2.64	5.49	-
1110G	0.56	1.14	3.30	6.81	-
1130G	0.61	1.32	3.61	7.98	-
1150G	0.69	1.55	4.17	9.32	-
1180G	0.74	1.83	4.22	9.65	-
1220G	0.99	2.21	5.87	13.31	-

## Selection of Puller Holes

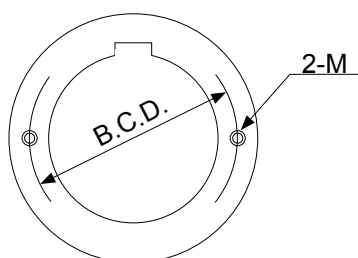

Size	B.C.D. (mm)	Bolt Size	Size	B.C.D. (mm)	Bolt Size
1010	52.32	M10 x 1.5 x 13	1040	180.98	M16 x 2 x 20
1015	69.85	M10 x 1.5 x 13	1045	200.03	M16 x 2 x 20
1020	88.9	M10 x 1.5 x 13	1050	215.9	M20 x 2.5 x 22
1025	112.78	M10 x 1.5 x 13	1055	238.13	M20 x 2.5 x 22
1030	128.52	M10 x 1.5 x 13	1060	263.53	M20 x 2.5 x 22
1035	152.40	M12 x 1.75 x 16	1070	311.15	M24 x 3 x 30



KCP Tapered Grid Couplings are shaft-to-shaft couplings that are of compact size, yet can handle torque capacity due to their high strength hardened alloy steel construction. The tapered grids are designed with a trapezoidal cross section and are tempered for spring hardness. Through a high-precision operation called shot peening, the surface molecules are compressed by high-velocity steel micro beads. The compression of the molecules results in dramatic increase in strength rating and provides reserve strength for a longer part life.

The tapered grids are accessible through the unit's removable cover. It is extremely easy to fit the trapezoidal grids into the slots of the hub, compared to fitting rectangular grids. There is no need for the equipment to be moved (hence downtime) so that couplings can be installed. Due to their compact size, the tapered grids can simply be placed directly in the slots of the hub. Finally, the practical split cover can be placed using standard tools.



## Protection Against Shaft Misalignment

The tapered grids are free to rock, pivot, and float within the hub teeth. This provides generous capacity for misalignment without producing the detrimental side loads on the bearings that are often created when couplings are misaligned.

## Protection Against Shock & Vibratory loads

KCP Tapered Grid Couplings are able to deflect torsionally when subjected to normal shock or vibratory loads, so they are able to handle changing load conditions. The system truly is a shock absorber for rotary motion, relying on the predictable resilience of the grid for torsional flexibility. The tapered grids "tune" the drive system. Due to their spring hardness, the grids absorb impact by spreading the impact energy over time. The grids can also damp vibration and reduce the peak or shock loads experienced by the rest of the system.

### Parallel Misalignment

- ▶ The movement of the grid in the lubricated grooves accommodates parallel misalignment and permits full functioning of the grid-groove action in damping out shock and vibration.

### Angular Misalignment

- ▶ Under angular misalignment, the grid-groove design permits a rocking and sliding action of the lubricated grid and hubs without any loss of power through the resilient grid.

### End Floating

- ▶ Unrestrained end float of driving and driven members is permitted because the grid slides freely in the lubricated grooves.

### Torsional Flexibility

- ▶ Torsional flexibility is the advantage of KCP Taper Grid Couplings, providing flexible accommodation to changing load conditions.

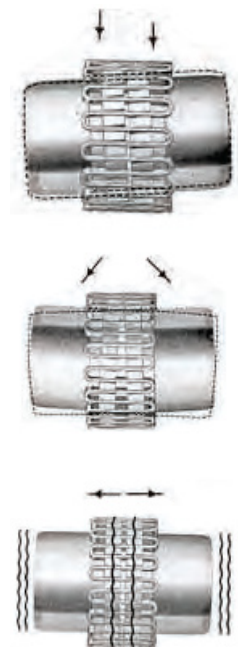



## Vibration & Shock

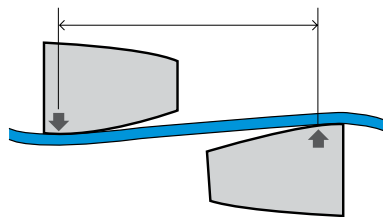
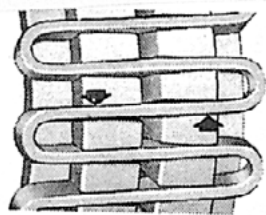
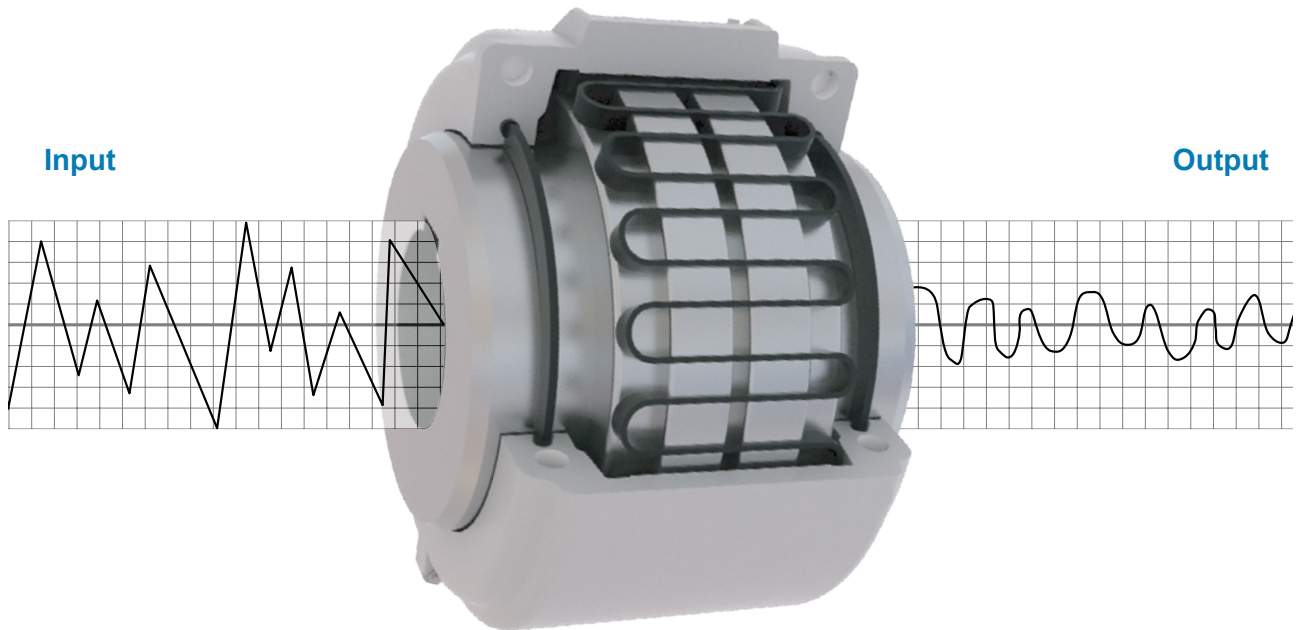

### Light Load

The grid contacts near the outer edges of the hub teeth. A long span between the points of contact remains free to flex under load.

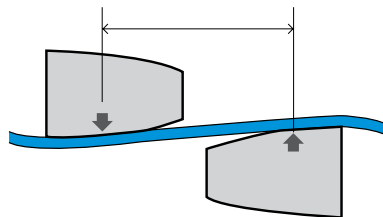
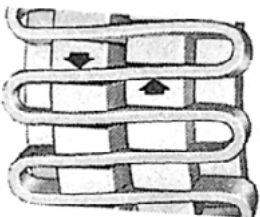

### Normal Load

As the load increases, the distance between the contact points on the hub teeth is shortened, but a free span still remains to cushion the load.

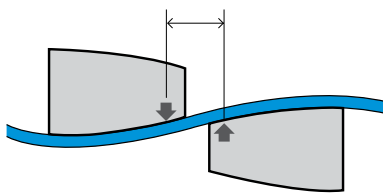
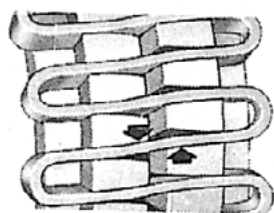

### Shock Load

The coupling is flexible within its rated capacity. Under extreme overloads, the grid bears fully on the hub teeth and transmits full load directly.

## Misalignment Capacity

Accurate alignment results in the maximum life and minimum maintenance for the coupling and the connected machinery. The amount of time for a coupling to reach its maximum operating limits is a function of load, operating speed, and lubrication. Maximum operating values listed in the table below are based on the allowable RPM listed on the catalogue. Values listed are based on the use of the specified gaps, use of standard coupling components, standard assemblies, and catalogue allowable speeds. Values may be combined for an installation or operating condition. Parallel misalignment is the distance between the centers of each shaft. Angular misalignment is dimension X minus dimension Y as shown in the drawing below. End float is the axial movement of the hubs within the covers as measured from "0" gap. This measure assumes zero angular and zero parallel misalignment.

**Parallel Misalignment**

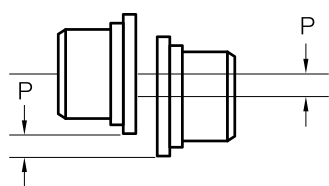

**Angular Misalignment**

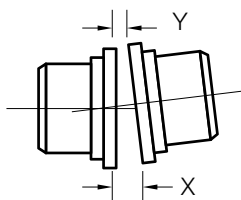

**End Float**

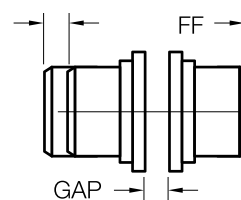

Coupling Size	Recommended Installation		Operating		Fastener Tightening Torque Values (Nm)
	Parallel Offset P Max (mm)	Angular (1/16°) X - Y Max (mm)	Parallel Offset-P Max (mm)	Angular (1/4°) X - Y Max (mm)	
1020	0.15	0.08	0.3	0.25	3
1030	0.15	0.08	0.3	0.30	3
1040	0.15	0.08	0.3	0.33	3
1050	0.20	0.10	0.4	0.41	3
1060	0.20	0.13	0.4	0.46	3
1070	0.20	0.13	0.4	0.51	3
1080	0.20	0.15	0.4	0.61	3
1090	0.20	0.18	0.4	0.71	3
1100	0.25	0.20	0.5	0.84	5
1110	0.25	0.23	0.5	0.91	5
1120	0.28	0.25	0.56	1.02	6
1130	0.28	0.30	0.56	1.19	6
1140	0.28	0.33	0.56	1.35	6
1150	0.30	0.41	0.6	1.57	6
1160	0.30	0.46	0.6	1.78	6
1170	0.30	0.51	0.6	2.01	6
1180	0.38	0.56	0.76	2.26	6
1190	0.38	0.61	0.76	2.46	6
1200	0.38	0.69	0.76	2.72	6

## Selection of Puller Holes

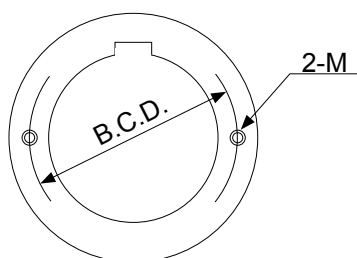

Coupling Size	B.C.D. (mm)	Bolt Size	Coupling Size	B.C.D. (mm)	Bolt Size
1070	74	M8	1150	227.5	M20
1080	89.5	M8	1160	260	M20
1090	106	M10	1170	306	M24
1100	121.5	M10	1180	341	M30
1110	136.5	M10	1190	373	M30
1120	150.5	M12	1200	414	M30
1130	185	M16	1210	540	M30
1140	205	M16	1220	570	M30

## Components

### Hubs

The grid coupling hubs are made from high tensile alloy steel and is precision machined to ensure superior performance and long life.

The hub attaches to the shafts of the machinery, providing a secure and stable connection point.



Component						
1020H-H	1030H-H	1040H-H	1050H-H	1060H-H	1070H-H	1080H-H
1090H-H	1100H-H	1110H-H	1120H-H	1130H-H	1140H-H	1150H-H

### Spring Element

The spring element in a grid coupling is a flexible, metallic grid-shaped component made of high-strength alloy steel. It is tempered to spring hardness and precision shot peened to increase its fatigue strength.

This grid-like structure fits between the teeth of the coupling hubs, connecting the two shafts.



Component						
1020H-G	1030H-G	1040H-G	1050H-G	1060H-G	1070H-G	1080H-G
1090H-G	1100H-G	1110H-G	1120H-G	1130H-G	1140H-G	1150H-G

## T10 Type - H (Horizontal Split Aluminium Cover)

The Type H cover is a horizontal split aluminium cover that is the best choice for limited spaces. It allows easy access to the grid spring and is suitable for reversing applications. The lightweight, die-cast aluminium grid cover enhances its practicality and ease of use.

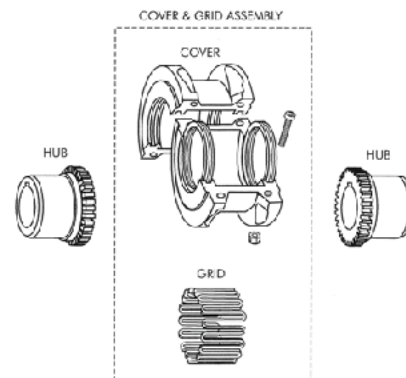
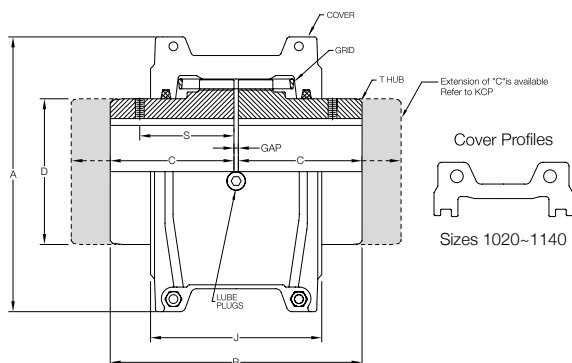
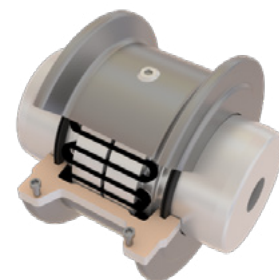

Size	Torque Rating (Nm)	Allow Speed (rpm)	Max Bore (mm)	Min Bore (mm)	Cplg Weight (kg)	Lube Weight (kg)	Dimensions (mm)							Size
							A	B	C	D	J	S	GAP	
1020	52	4,500	28	13	1.92	0.0272	101.0	98.2	47.6	39.7	67.8	39.1	3	1020
1030	149	4,500	35	13	2.58	0.0408	109.0	98.2	47.6	49.2	71.9	39.1	3	1030
1040	249	4,500	43	13	3.34	0.0544	116.0	104.6	50.8	57.2	72.0	40.1	3	1040
1050	435	4,500	50	13	5.44	0.0680	137.8	123.6	60.3	66.7	81.6	44.7	3	1050
1060	684	4,350	56	20	7.44	0.0862	147.0	130.0	63.5	76.2	97.9	52.3	3	1060
1070	994	4,125	67	20	10.40	0.113	162.2	155.4	76.2	87.3	99.2	53.8	3	1070
1080	2,050	3,600	80	27	17.90	0.172	193.0	180.8	88.9	104.8	118.4	64.5	3	1080
1090	3,730	3,600	95	27	25.60	0.254	212.0	199.8	98.4	123.8	127.4	71.6	3	1090
1100	6,280	2,440	110	42	42.00	0.426	250.7	246.2	120.6	142.1	156.6	-	5	1100
1110	9,320	2,250	120	42	54.30	0.508	270.0	259.0	127.0	160.3	162.6	-	5	1110
1120	13,700	2,025	140	61	81.20	0.735	306.4	304.4	149.2	179.4	191.7	-	6	1120
1130	19,900	1,800	170	67	121.00	0.907	343.8	329.8	161.9	217.5	195.5	-	6	1130
1140	28,600	1,650	200	67	178.00	1.130	383.8	374.4	184.2	254.0	201.7	-	6	1140

\* Coupling Weight is without Bore Machining. Measurements in millimetres.

## T10 Type - H (Horizontal Split Aluminium Cover) Large

The Type H cover is a horizontal split aluminium cover that is the best choice for limited spaces. It allows easy access to the grid spring and is suitable for reversing applications. The lightweight, die-cast aluminium grid cover enhances its practicality and ease of use.



Size	Torque Rating (Nm)	Allow Speed (rpm)	Max Bore (mm)	Min Bore (mm)	Cplg Weight (kg)	Lube Weight (kg)	Dimensions (mm)						Size
							A	B	C	D	J	GAP	
1150	39,800	1,500	215	108	234	1.95	453.1	371.8	182.9	269.2	271.5	6	1150
1160	55,900	1,350	240	121	317	2.81	501.9	402.2	198.1	304.8	278.4	6	1160
1170	74,600	1,225	280	134	448	3.49	566.9	437.8	215.9	355.6	307.3	6	1170
1180	103,000	1,100	300	153	619	3.76	629.9	483.6	238.8	393.7	321.1	6	1180
1190	137,000	1,050	335	153	776	4.40	675.6	524.2	259.1	436.9	325.1	6	1190
1200	186,000	900	360	178	1058	5.62	756.9	564.8	279.4	497.8	355.6	6	1200
1210	249,000	820	390	178	1424	10.50	844.6	622.6	304.8	533.4	431.8	13	1210
1220	336,000	730	420	203	1785	16.10	920.8	663.2	325.1	571.5	490.2	13	1220
1230	435,000	680	450	203	2267	24.00	1,003.3	703.8	345.4	609.6	546.1	13	1230
1240	559,000	630	480	254	2950	33.80	1,087.1	749.6	368.3	647.7	647.7	13	1240
1250	746,000	580	-	254	3833	50.10	1,181.1	815.6	401.3	711.2	698.5	13	1250
1260	932,000	540	-	254	4682	67.20	1,260.9	876.6	431.8	762.0	762.0	13	1260

\* Coupling Weight is without Bore Machining. Measurements in millimetres.

## T20 Type V (Vertical Split Steel Cover)

The KCP T20 Type V cover is a vertical steel cover, ideal for high operating speeds. It allows easy access to the grid spring and features a steel grid cover for enhanced strength.

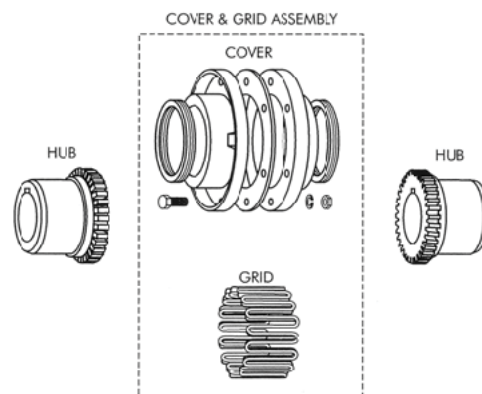
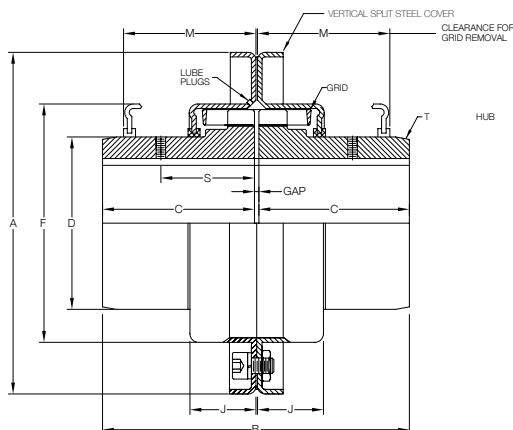

Size	Torque Rating (Nm)	Allow Speed (rpm)	Max Bore (mm)	Min Bore (mm)	Cplg Weight (kg)	Lube Weight (kg)	Dimensions (mm)								Size
							A	B	C	D	F	J	M	GAP	
1020	52	6,000	28	13	1.94	0.0272	112.3	98.2	47.6	39.7	64.3	23.9	47.8	3	1020
1030	149	6,000	35	13	2.58	0.0408	121.8	98.2	47.6	49.2	73.8	24.9	47.8	3	1030
1040	249	6,000	43	13	3.35	0.0544	129.8	104.6	50.8	57.2	81.8	25.9	50.8	3	1040
1050	435	6,000	50	13	5.32	0.0680	148.8	123.6	60.3	66.7	97.6	30.5	60.5	3	1050
1060	684	6,000	56	20	7.01	0.0862	163.1	130.0	63.5	76.2	111.1	31.8	63.5	3	1060
1070	994	5,500	67	20	10.20	0.1130	174.2	155.4	76.2	87.3	122.3	33.5	66.5	3	1070
1080	2,050	4,750	80	27	17.60	0.1720	201.2	180.8	88.9	104.8	149.2	43.7	88.9	3	1080
1090	3,730	4,000	95	27	25.40	0.2540	232.9	199.8	98.4	123.8	168.3	47.0	95.2	3	1090
1100	6,280	3,600	110	42	42.00	0.4260	267.9	246.2	120.6	142.1	198.0	59.7	120.7	5	1100
1110	9,320	3,000	120	42	54.40	0.5080	286.9	259.0	127.0	160.3	216.3	62.7	124.0	5	1110
1120	13,700	2,700	140	61	81.80	0.7350	320.2	304.4	149.2	179.4	245.5	73.7	142.7	6	1120
1130	19,900	2,400	170	67	122.00	0.9070	379.0	329.8	161.9	217.5	283.8	74.9	146.0	6	1130
1140	28,600	2,200	200	67	180.00	1.1300	417.1	374.4	184.2	254.0	321.9	78.2	155.4	6	1140
1150	39,800	2,000	215	108	230.00	1.9500	476.2	371.8	182.9	269.2	374.4	107.3	203.2	6	1150
1160	55,900	1,750	240	121	321.00	2.8100	533.4	402.2	198.1	304.8	423.9	115.3	215.9	6	1160
1170	74,600	1,600	280	134	448.00	3.4900	584.2	437.8	215.9	355.6	474.7	120.1	226.1	6	1170
1180	103,000	1,400	300	153	591.00	3.7600	630.0	483.6	238.8	393.7	546.0	130.0	-	6	1180
1190	137,000	1,300	335	153	761.00	4.4000	685.0	524.2	259.1	436.9	589.0	135.0	-	6	1190
1200	186,000	1,100	360	178	1021.00	5.6200	737.0	564.8	279.4	497.8	652.0	145.0	-	6	1200

\* Coupling Weight is without Bore Machining. Measurements in millimetres.

## Lubrication

Choose high-quality lubricant for KCP Taper Grid Couplings for good performance and long life.

### Grease

- ▶ Grease on the grid and hub teeth before assembling covers
- ▶ Fill up grease through the lub plug of the assembled coupling.

### Supplement

- ▶ Every three month Every 240~250 hours operating, you should add grease.

### Replacement

- ▶ Every 3 months, or every 4,000 hours operating you should replace all the deteriorated grease.

### Selection

- ▶ Choose grease according to the ambient temperature range in the table below.

## Common Industrial Lubricants (NYGL Grade #2)

Manufacture	Ambient Temperature Range	
	0° F to 150° F (-18° C TO 66° C)	-30° F to 100° F (-34° C TO 38° C)
Amoco Oil Co.	Amolith Grease #2	Amolith Grease #2
Atlantic Richfield Co.	Litholene HEP 2	Litholene HEP 2
Chevron U.S.A. Inc.	Chevron Dura-Lith EP-2	Chevron Dura-Lith EP-2
Cities Service Co.	Citgo HEP-2	Citgo HEP-2
Conoco Inc.	EP Conolith #2	EP Conolith #2
Exxon Company, U.S.A.	Ronex MP	Ronex MP
Gulf Oil Corp.	Gulfcrown Grease #2	Gulfcrown Grease #2
E.F. Houghton & Co.	Cosmolube #2	Cosmolube #1
Imperial Oil Ltd.	Esso MP Grease H	Lotemp EP
Keystone Div. (Pennwalt)	#81 Light	#84 Light
Mobil Oil Corp.	Mobilux EP111	Mobilux #1
Phillips Petroleum Co.	IB & RB Grease	Philube IB & RB Grease
Shell Oil Co.	Alvania Grease #2	Alvania Grease #2
Standard Oil Co. (OH)	Factran #2	Factran #2
Sun Oil Company	Prestige 42	Prestige 42
Texaco Lubricants	Starplex HD 2	Multifac EP2
Union Oil Co. (CA)	Union Undoba #2	Union Undoba #2
Valvoline Oil Co.	Val-Lith EP #2	Val-Lith EP #2



## Installation

Requirements are wrenches, a straight edge and feeler gauges to install KCP Taper Grid Couplings. Taper Grid Coupling size from 1020 to 1090 are furnished for a clearance fit with a setscrew over the keyway. Larger sizes (from 1100 and up) are furnished for an interference fit without a setscrew.

### Clearance fit Hubs

Clean all parts using a non-flammable solvent. Check hubs, shafts and key ways for burrs. Install keys. Mount hubs with the flange face flush with shaft ends (or as otherwise specified). Tighten setscrews. Do not heat clearance fit hubs.

### Interference Fit Hubs

Furnished without setscrews.

#### 1. Mount Seals and Hubs

Lock out starting switch of prime mover. Clean metal parts using a non-flammable solvent. Lightly coat seals with grease and place on shafts before mounting hubs. Heat interference fit hubs. Seal keyways to prevent leakage. Mount hubs on their corresponding shafts so that the hub face is flush with the end of the shaft (unless otherwise indicated).

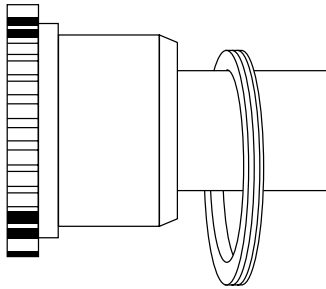

#### 2. Gap and Alignment

Use a spacer bar equal in thickness to the gap between shafts (Page 11-12) Insert bar and same depth at 90° intervals and measure clearance between bar and hub face with feelers. The difference in minimum and maximum measurements must not exceed the angular installation limits.

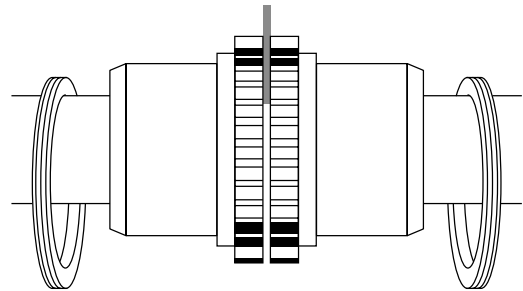

#### 3. Offset Alignment

Align a straight edge so that it rests squarely on both hubs as shown in the diagram. Check with feelers. The clearance must not exceed the parallel offset installation limits. Tighten all foundation bolts and repeat Steps 2 and 3. Realign coupling if necessary.

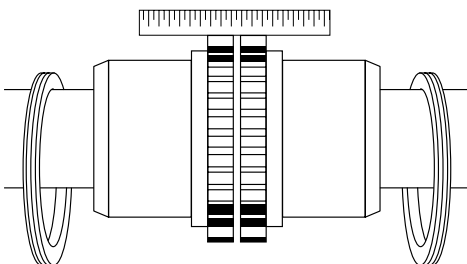

#### 4. Insert Grid

Pack the gap and grooves with specified lubricant before inserting grid. When grids are furnished in two or more segments, install them so that all cut ends extend in the same direction. This will assure correct contact between the grid and any non-rotating pins in each half of the covers. Spread the grid just enough so that it passes over the coupling teeth. Seat with a soft mallet.

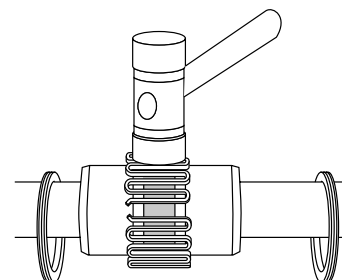



### 5. Pack

Pack any spaces between and around the grid with as much lubricant as possible. Wipe off any excess so that any remaining lubricant is flush with top of grid. Position hub seals to line up with the grooves in the cover. Position gaskets on lower cover half flange and assemble the two covers so that the match marks are on the same side. If shafts are not horizontally level, or if the coupling is to be used vertically, assemble cover halves with the lug so that the match marks are up or are on the high side. Push gaskets in against the seals as far as possible. Secure cover halves with fasteners and tighten to torque. Make sure gaskets stay in position while the fasteners are tightened.

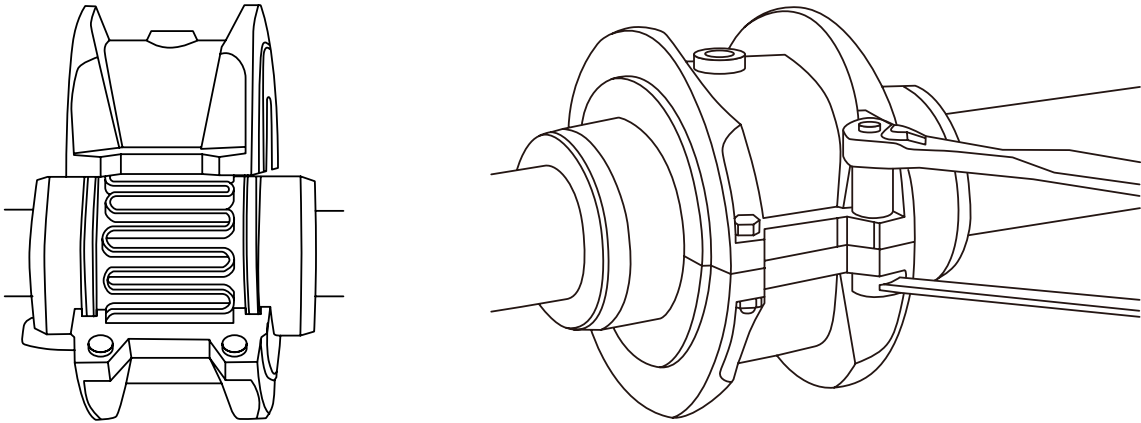

## Annual Maintenance

### Items to perform annually

1. Check alignment. If the maximum operating misalignment limits are exceeded, realign the coupling to the recommended installation limits.
2. Check that all fasteners are tightened to torque.
3. Inspect Oil Seal and Gasket to determine if replacement is required. Replace if the Seal and Gasket is leaking grease.
4. Disassemble the coupling and inspect for wear. Replace any worn parts. Clean grease from coupling and repack with new grease. Install coupling using a new gasket as instructed in this manual.

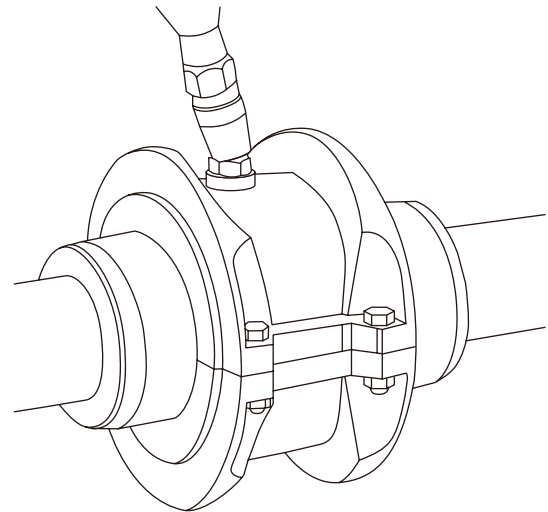

# Rigid Couplings

Also known as a sleeve, compression and flange coupling, the rigid coupling provides a solid connection between two shafts, for high precision and torque.

## Our range

- ▶ Clamp & Split Couplings
- ▶ RM Rigid Couplings



Rigid couplings are available in one and two piece clamp designs, with and without keyways in steel or stainless steel. Clamp style rigid couplings wrap around the shaft, providing high torsional holding power without the shaft damage and fretting that occurs when set screw style couplings are used. Two-piece clamp styles also allow for disassembly and maintenance without removal of other machine components and feature opposing hardware for a balanced design.

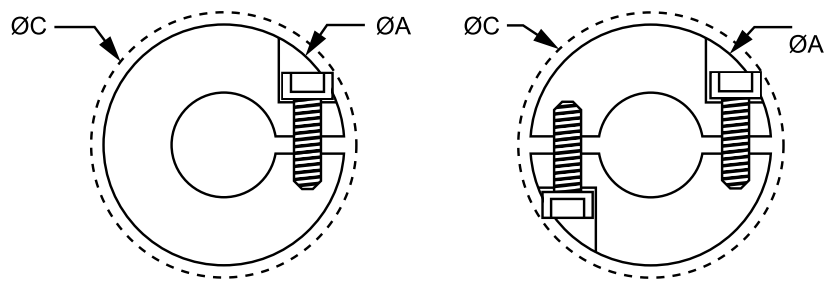
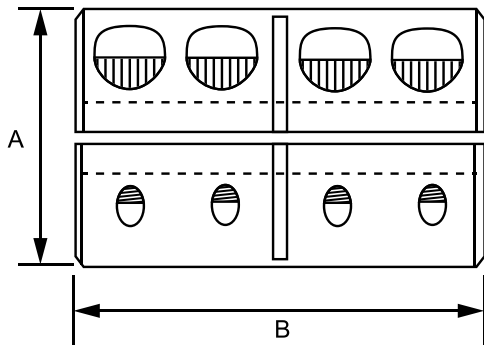

Part No.		Bore (mm)	A	B	C
One Piece Split	Two Piece Split				
MCLX-3-3*	MSPX-3-3	3.0	15.0	22.0	15.0
MCLX-4-4	MSPX-4-4	4.0	15.0	22.0	15.0
MCLX-5-5	MSPX-5-5	5.0	15.0	22.0	15.0
MCLX-6-6	MSPX-6-6	6.0	18.0	30.0	21.5
MCLX-8-8	MSPX-8-8	8.0	24.0	35.0	27.1
MCLX-10-10	MSPX-10-10	10.0	29.0	45.0	33.0
MCLX-12-12	MSPX-12-12	12.0	29.0	45.0	33.0
MCLX-14-14	MSPX-14-14	14.0	34.0	50.0	39.4
MCLX-15-15	MSPX-15-15	15.0	34.0	50.0	39.4
MCLX-16-16	MSPX-16-16	16.0	34.0	50.0	39.4
MCLX-20-20	MSPX-20-20	20.0	42.0	65.0	48.9
MCLX-25-25	MSPX-25-25	25.0	45.0	75.0	51.5
MCLX-30-30	MSPX-30-30	30.0	53.0	83.0	58.7
MCLX-35-35	MSPX-35-35	35.0	67.0	95.0	74.7
MCLX-40-40	MSPX-40-40	40.0	77.0	108.0	84.0
MCLX-50-50	MSPX-50-50	50.0	85.0	124.0	94.2

Metric clamp and split coupling specification table.

Rigid couplings are available in one and two piece clamp designs, with and without keyways in steel or stainless steel. Clamp style rigid couplings wrap around the shaft, providing high torsional holding power without the shaft damage and fretting that occurs when set screw style couplings are used. Two-piece clamp styles also allow for disassembly and maintenance without removal of other machine components and feature opposing hardware for a balanced design.

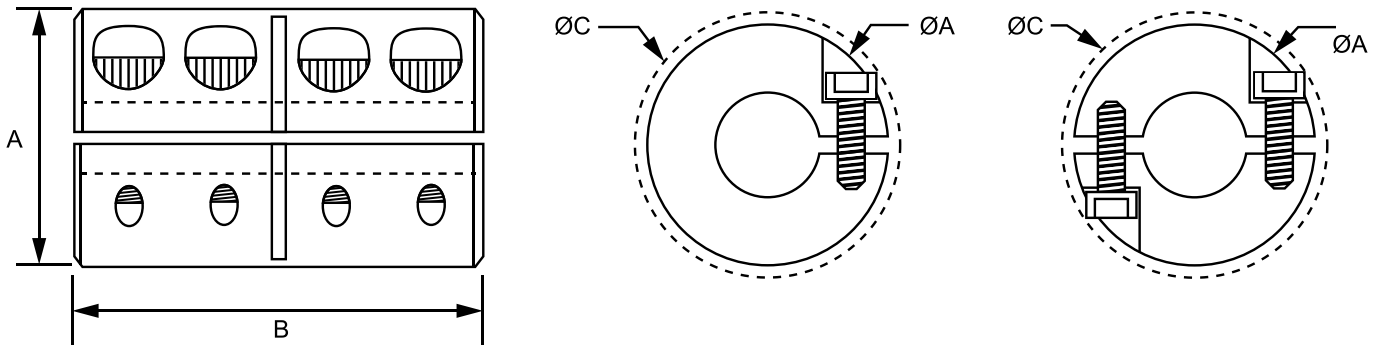

Part No.		Bore (Inches)	A	B	C
One Piece Split	Two Piece Split				
CLX-4-4	SPX-4-4	6.4 (1/4")	15.9	25.4	20.7
CLX-6-6	SPX-6-6	9.5 (3/8")	22.2	34.9	26.2
CLX-8-8	SPX-8-8	12.7 (1/2")	28.6	44.5	33.7
CLX-10-10	SPX-10-10	15.9 (5/8")	33.3	50.8	38.5
CLX-12-12	SPX-12-12	19.1 (3/4")	38.1	57.2	46.8
CLX-14-14	SPX-14-14	22.2 (7/8")	41.3	63.5	49.1
CLX-16-16	SPX-16-16	25.4 (1")	44.5	76.2	52.0
CLX-18-18	SPX-18-18	28.6 (1 1/8")	47.6	79.4	55.4
CLX-20-20	SPX-20-20	31.8 (1 1/4")	52.4	82.6	58.1
CLX-22-22	SPX-22-22	34.9 (1 3/8")	63.5	92.1	70.4
CLX-24-24	SPX-24-24	38.1 (1 1/2")	66.7	98.4	73.3
CLX-28-28	SPX-28-28	44.5 (1 3/4")	79.4	114.3	85.5
CLX-32-32	SPX-32-32	50.8 (2")	85.7	123.8	94.4

Imperial clamp and split coupling specification table.

RM Rigid couplings are used to rigidly connect two shafts. Rigid couplings are often used to facilitate ease-of-maintenance or simply to aid machine assembly. TaperFit bushes provide a secure fit on the driving and driven shafts, ensuring installation and removal is simple.

### Selection Procedure

- ▶ Select a size of RM Rigid Coupling to fit the larger of the driving or driven shafts.
- ▶ For severe applications, select the next size up RM Rigid Coupling.

Note: HF or FF assemblies can be used on horizontal shafts, only FF assemblies are to be used on vertical shafts.



Coupling Assembly HF

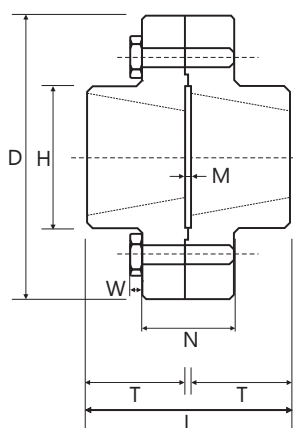

Coupling Assembly FF

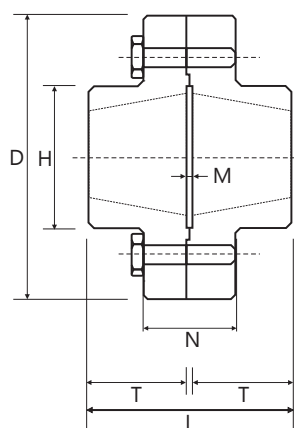

Dimensions	RM12	RM16	RM25	RM30	RM35	RM40	RM45	RM50
TF Bush Size: F & H Flanges	1210*	1615*	2517	3030	3535	4040	4545	5050
Maximum Bore: F & H Flanges	32	42	65	75	90	100	110	125
D - Outside Diameter	118	127	178	216	248	298	330	362
H - Hub Diameter	83	80	123	146	178	210	230	266
L - Assembled Length	57	83	97	159	185	210	235	260
M - Gap	7	7	7	7	7	7	7	7
N - Outer Length	35	43	51	65	75	76	86	92
W - Wrench Clearance (H Flange only)	38	38	48	54	67	79	86	92
Total Weight (kg)	3.5	4.5	11	23	38	64	88	155

All values are in mm unless otherwise stated.

### Ordering instructions

- ▶ Couplings are supplied as complete assemblies in either HF or FF Configuration (e.g a RM25 configured as a HF is specified RM25HF).
- ▶ Couplings require Bushes which must be ordered as separate items (specifying bush size and the required bores).  
All dimensions are in mm unless otherwise stated.

# TRANSDRIVE®

## DRIVE PERFORMANCE

Need more information about  
TransDrive products, customised  
products and services, get in touch.

[info@transdrive.com.au](mailto:info@transdrive.com.au)  
[transdrive.com.au](http://transdrive.com.au)

Supplier

