



# MOTOR CATALOGUE

DISTRIBUTED BY



**CHAIN & DRIVES**  
COMPLETE BEARINGS  
& POWER TRANSMISSION

**SERVICE & SUPPORT**

Wangara, WA      Welshpool, WA      Arndell Park, NSW  
+61 8 9303 4966    +61 8 6314 1155    +61 2 9674 8611  
support@chainanddrives.com.au    salesnsw@chainanddrives.com.au

[chainanddrives.com.au](http://chainanddrives.com.au)

**Quality. Service. Range**





Shanghai Top Motor Company, one of the leading motor manufacturers in China have recently established a commercial operation in Australia.

Techtop Australia Pty Ltd, based in the outer eastern suburbs of Melbourne, will import and distribute the internationally recognised "TECHTOP" brand of electric motors.

Founded by well-respected Directors, Rohan Pollard and Jeff Aird, Techtop Australia combines local market knowledge with leading overseas manufacturing capabilities

to provide its customers with the very latest and highest quality products.

Techtop Australia's extensive range covers single and three phase TEFC electric motors in both Aluminium and Cast Iron.

The company's strength is based on its professional and enthusiastic staff whom are constantly multi-tasking to ensure customer service is held at the forefront of the business. Techtop Australia have product experienced staff who take a genuine interest in their customers' requirements.

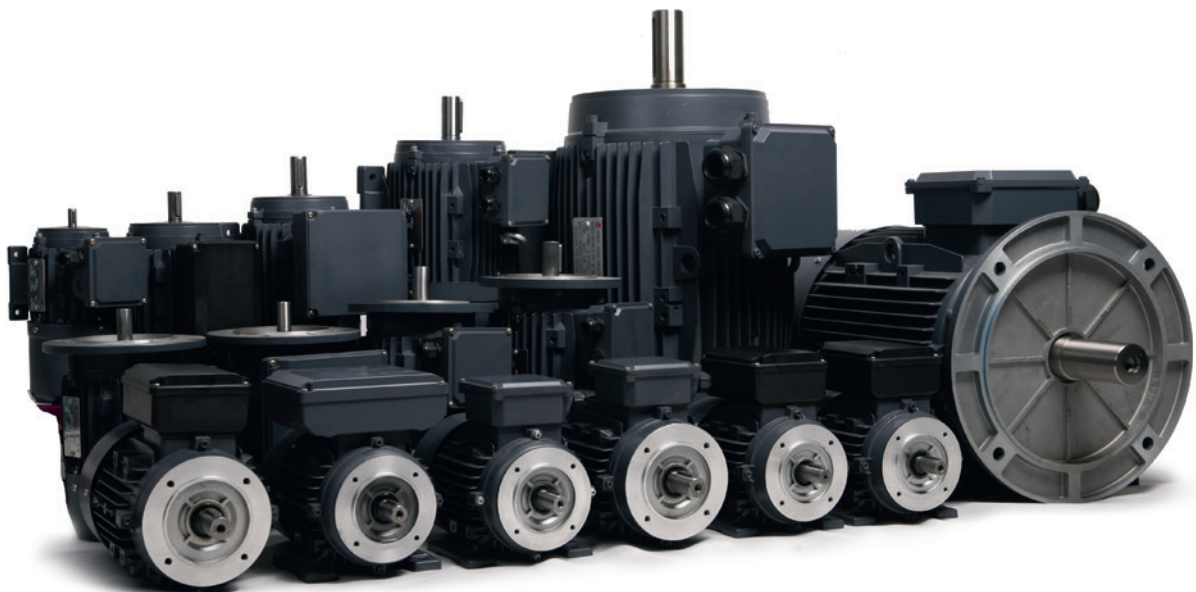

# TABLE OF CONTENTS

## Single Phase Motors

Page



### TMY PERMANENT SPLIT CAPACITOR

TM Series Introduction ..... 4

TMY Performance Data ..... 5

TMY Dimensional Data ..... 6



### TML CAP START / CAP RUN

TML Performance Data ..... 5

TML Dimensional Data ..... 7

## Three Phase Motors



### TAI ALUMINIUM

Introduction ..... 8-9

Performance Data ..... 10

Dimensional Data ..... 11



### TAIB ALUMINIUM BRAKE

Introduction ..... 12

Brake Data ..... 12

Dimensional Data ..... 13

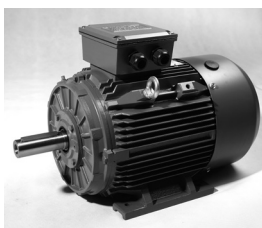

### TCI CAST IRON

Introduction ..... 14-16

Performance Data ..... 17-18

Dimensional Data ..... 19

## TM Series – Aluminium Single Phase

0.06kW to 3.7kW – Sizes 56 to 112

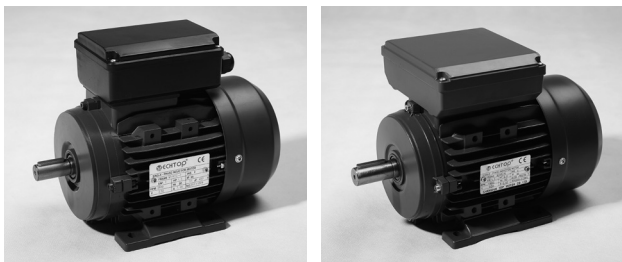

Techtop’s TM series are ideally suited to general purpose applications and are available in both permanent split capacitor (TMY) and cap/start–cap/run (TML) series.

### Operating parameters

Standard TM series motors are designed with the following parameters:

- ⚡ 220V to 240V, 50Hz supply
- ⚡ Continuous (S1) duty
- ⚡ Ambient temperatures up to 40°C
- ⚡ Installation up to 1000 MASL

### Standards

Dimensions and rated outputs for the TM series conform to Australian Standard AS/NZS 1359 and International Standards IEC 60034 and IEC 60072.

### Insulation class

TM motors are insulated with Class F materials and limited to Class B temperature rise.

### IP Protection

The standard degree of enclosure protection is IP 55 (increased IP protection is available). Shafts are fitted with an oil seal as standard.

### Multi-mount design

As standard, TM series motors are fitted with detachable feet. The multi-mount design allows for the motor feet to be removed and repositioned to either side to produce a side mounted terminal box.

### Fan & Gearbox application

TM series motors are low weight design and come standard with a drilled and tapped hole in the shaft which makes this series ideal for fan applications. This motor series is also ideally suited for fitting to aluminium gearboxes.

### Terminal box

The terminal box is manufactured from aluminium and is mounted on top of the motor as standard.

### Bearings

Bearings fitted are high quality NSK deep groove ball bearings that are sealed for life.

Frame Size	Bearing Size DE/NDE
56	6201 ZZ
63	6201 ZZ
71	6202 ZZ
80	6204 ZZ
90	6205 ZZ
100	6206 ZZ
112	6206 ZZ

### Surface Finish

As standard TM motors are painted with high quality alkyd enamel with the final colour being RAL 7024 Graphite Grey. Other colours are available upon request.

### Part Number Logic

Detailed below is the part number logic which should be specified when placing orders. The part number is composed in accordance with the following example:

T	A	4	B	0	1	1	3	TML
1	2	3	4	5-7			8	9-11

Position 1	Position 5 to 7	
T = Techtop	Output kW	
Position 2	Position 8	
A = Aluminium	Mounting position	
2 = 2 Pole	1 = V1	3 = B3
4 = 4 Pole	4 = B3/5	5 = B5
Position 3	6 = B3/B14A	7 = B14A
2 = 2 Pole	8 = B14B	9 = B3/B14B
4 = 4 Pole	A = B5R	B = B3/B5R
Position 4	Position 9 to 11	
A = less than 0.99kW	TML = CS/CR series	
B = 1.0kW to 9.9kW	TMY = PSC series	

**TMY DATA**

Output kW	Full Load Speed [RPM]	Frame Size	Shaft Dia [mm]	Current @ 240v		Efficiency	Power Factor	Torque			Capacitor Run Capacitor [mfd/volt]	Weight Foot Mount [Kg]
				Full Load [A]	Locked Rotor [%]			Full Load [%]	Full Load [Nm]	Locked Rotor [% FLT]		
0.09	2760	56A	9	0.76	380	54.0	0.94	0.3	0.65	160	4/450	2.9
0.12	2770	56B	9	0.94	410	58.0	0.92	0.4	0.65	160	6/450	3.2
0.18	2780	63A	11	1.3	380	62.0	0.95	0.6	0.60	170	10/450	4.0
0.25	2780	63B	11	1.7	400	65.0	0.95	0.9	0.60	170	12/450	4.5
0.37	2800	71A	14	2.4	400	67.0	0.95	1.3	0.60	170	16/450	5.1
0.55	2810	71B	14	3.3	430	70.0	0.98	1.9	0.55	170	24/450	7.2
0.75	2810	80A	19	4.4	430	72.0	0.98	2.5	0.35	170	25/450	9.6
1.1	2820	80B	19	6.2	430	75.0	0.98	3.7	0.33	170	35/450	11.0
1.5	2820	90S	24	8.1	460	76.0	0.98	5.1	0.30	180	45/450	14.0
2.2	2820	90L	24	12.2	470	77.0	0.98	7.5	0.30	180	60/450	16.5
0.06	1360	56A	9	0.57	420	48.0	0.92	0.4	0.75	160	4/450	3.5
0.09	1370	56B	9	0.80	360	51.0	0.92	0.6	0.75	160	6/450	3.8
0.12	1380	63A	11	0.99	340	55.0	0.92	0.8	0.65	160	10/450	4.0
0.18	1390	63B	11	1.4	370	57.0	0.92	1.2	0.65	150	10/450	4.6
0.25	1400	71A	14	1.8	420	61.0	0.94	1.7	0.50	150	14/450	5.7
0.37	1400	71B	14	2.4	360	62.0	0.94	2.5	0.50	150	16/450	6.7
0.55	1400	80A	19	3.8	380	64.0	0.95	3.8	0.35	170	20/450	8.2
0.75	1410	80B	19	4.8	400	68.0	0.95	5.1	0.33	170	25/450	9.0
1.1	1410	90S	24	6.6	440	71.0	0.98	7.5	0.33	180	40/450	14.5
1.5	1420	90L	24	8.7	440	73.0	0.98	10.1	0.33	180	45/450	16.2

**TML DATA**

Output kW	Full Load Speed [RPM]	Frame Size	Shaft Dia [mm]	Current @ 240v		Efficiency	Power Factor	Torque			Capacitor		Weight Foot Mount [Kg]
				Full Load [A]	Locked Rotor [%]			Full Load [%]	Full Load [Nm]	Locked Rotor [% FLT]	Break Down [% FLT]	Start Capacitor [mfd/volt]	
0.37	2780	71A	14	2.3	620	70.0	0.95	1.3	250	170	75/250	12/450	5.3
0.55	2790	71B	14	3.3	580	73.0	0.95	1.9	250	170	100/250	16/450	7.4
0.75	2800	80A	19	4.4	660	74.0	0.97	2.6	250	170	100/250	20/450	9.5
1.1	2810	80B	19	6.2	620	76.0	0.97	3.7	250	170	150/250	30/450	11.2
1.5	2810	90S	24	8.3	640	78.0	0.97	5.1	250	180	200/300	40/450	14.0
2.2	2810	90L	24	12	600	79.0	0.97	7.5	220	180	250/300	50/450	17.0
3	2830	100L	28	15.9	570	80.0	0.98	10.1	220	200	350/300	60/450	25.0
0.18	1320	63A	11	1.41	470	55.0	0.99	1.3	250	150	40/450	12/450	4.9
0.25	1380	71A	14	1.9	520	61.0	0.92	1.7	250	160	50/250	14/450	5.9
0.37	1380	71B	14	2.7	540	63.0	0.92	2.6	250	150	75/250	16/450	6.9
0.55	1400	80A	19	3.6	530	67.0	0.94	3.8	250	170	100/250	20/450	9.6
0.75	1410	80B	19	4.5	630	73.0	0.94	5.1	250	170	120/250	25/450	10.8
1.1	1410	90S	24	6.5	590	75.0	0.95	7.5	220	180	150/250	35/450	13.5
1.5	1420	90L	24	8.7	610	76.0	0.95	10.1	220	180	200/300	40/450	16.5
2.2	1430	100LA	28	12.1	600	78.0	0.97	14.7	220	180	350/300	50/450	24.0
3	1440	100LB	28	16.3	560	79.0	0.97	19.9	220	180	500/300	60/450	30.0
3.7	1440	112M	28	19.8	580	80.0	0.97	24.5	200	200	500/300	60/450	36.0

### MOTOR OUTLINE DIMENSIONS

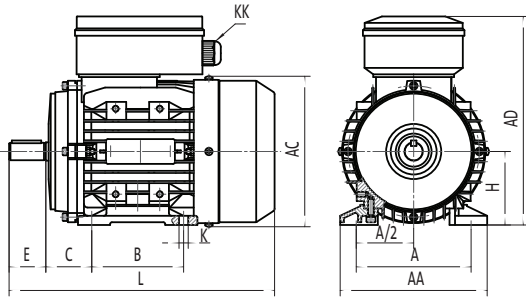

**B3**

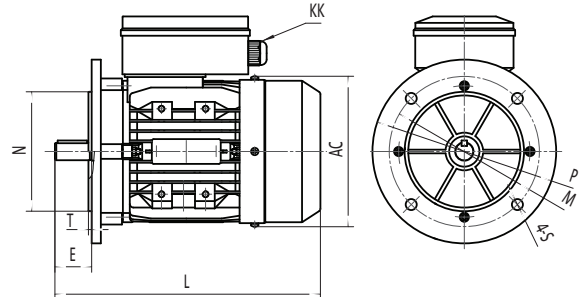

**B5**

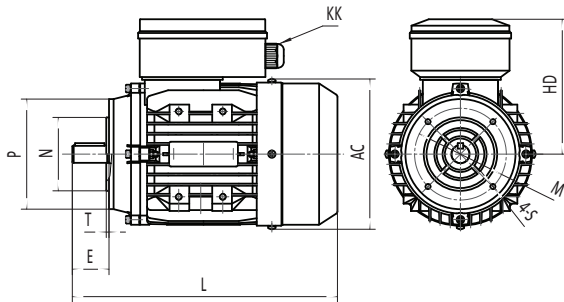

**B14**

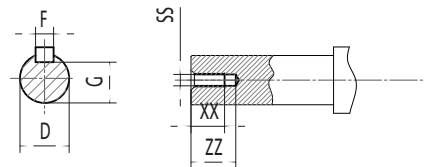

**SHAFT**

### TMY DATA

Frame Size	Foot Mounting				Shaft								General				
	H	A	B	C	D	E	F	G	K	SS	XX	ZZ	AA	AD	HD	AC	L
TMY 56	56	90	71	36	9	20	3	7.2	5.8	M3	9	12	110	144	88	117	196
TMY 63	63	100	80	40	11	23	4	8.5	7	M4	10	14	120	181	118	130	220
TMY 71	71	112	90	45	14	30	5	11	7	M5	12	17	132	196	125	147	241/255
TMY 80	80	125	100	50	19	40	6	15.5	10	M6	16	21	160	226	146	163	290
TMY 90S	90	140	100	56	24	50	8	20	10	M8	19	25	175	243	153	183	312
TMY 90L	90	140	125	56	24	50	8	20	10	M8	19	25	175	243	153	183	337/367
TMY 100L	100	160	140	63	28	60	8	24	12	M10	22	30	198	265	165	205	369/387

Frame Size	KK	B5					B14A					B5R					B14B					
		N	M	P	S	T	N	M	P	S	T	N	M	P	T	S	N	M	P	T	S	
TMY 56	1-M16*1.5	80	100	120	4-7	3	50	65	80	M5	2.5											
TMY 63	1-M20*1.5	95	115	140	4-10	3	60	75	90	M5	2.5						80	100	120	3	M6	
TMY 71	1-M20*1.5	110	130	160	4-10	3.5	70	85	105	M6	2.5	95	115	140	3	10	95	115	140	3	M8	
TMY 80	1-M20*1.5	130	165	200	4-12	3.5	80	100	120	M6	3	110	130	160	3.5	10	110	130	160	3.5	M8	
TMY 90	1-M20*1.5	130	165	200	4-12	3.5	95	115	140	M8	3	110	130	160	3.5	10	110	130	160	3.5	M8	
TMY 100	1-M20*1.5	180	215	250	4-15	4	110	130	160	M8	3.5	130	165	200	3.5	12	130	165	200	3.5	M10	

### MOTOR OUTLINE DIMENSIONS

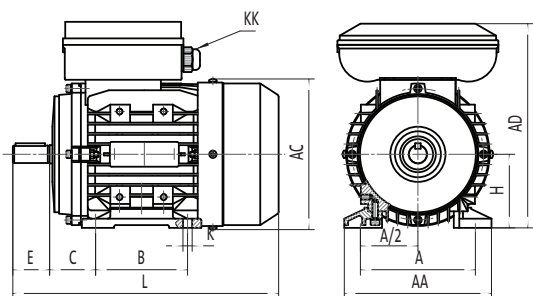

**B3**

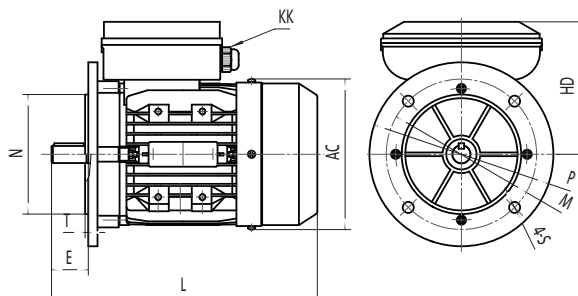

**B5**

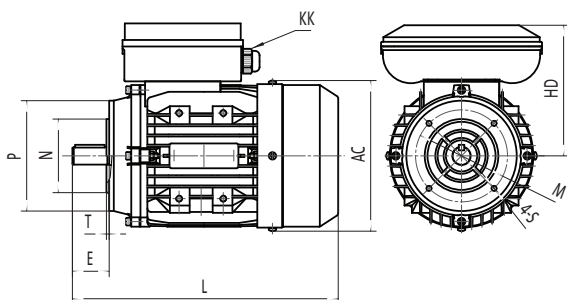

**B14**

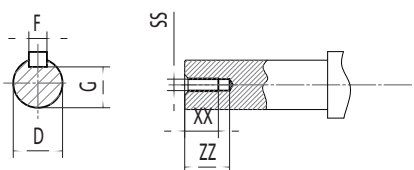

**SHAFT**

### TML DATA

Frame Size	Foot Mounting				Shaft								General				
	H	A	B	C	D	E	F	G	K	SS	XX	ZZ	AA	AD	HD	AC	L
TML 63	63	100	80	40	11	23	4	8.5	7	M4	10	14	120	179	116	130	215
TML 71	71	112	90	45	14	30	5	11	7	M5	12	17	132	194	123	147	255
TML 80	80	125	100	50	19	40	6	15.5	10	M6	16	21	160	223	143	163	290
TML 90S	90	140	100	56	24	50	8	20	10	M8	19	25	175	240	150	183	335
TML 90L	90	140	125	56	24	50	8	20	10	M8	19	25	175	240	150	183	365
TML 100L	100	160	140	63	28	60	8	24	12	M10	22	30	198	271	171	205	405(423)
TML 112M	112	190	140	70	28	60	8	24	12	M10	22	30	220	297	185	229	435

Frame Size	KK	B5					B14A					B5R					B14B					
		N	M	P	S	T	N	M	P	S	T	N	M	P	T	S	N	M	P	T	S	
TML 63	1-M20*1.5	95	115	140	4-10	3	60	75	90	M5	2.5											
TML 71	1-M20*1.5	110	130	160	4-10	3.5	70	85	105	M6	2.5	95	115	140	3	10	95	115	140	3	M8	
TML 80	1-M20*1.5	130	165	200	4-12	3.5	80	100	120	M6	3	110	130	160	3.5	10	110	130	160	3.5	M8	
TML 90	1-M20*1.5	130	165	200	4-12	3.5	95	115	140	M8	3	110	130	160	3.5	10	110	130	160	3.5	M8	
TML 100	1-M20*1.5	180	215	250	4-15	4	110	130	160	M8	3.5	130	165	200	3.5	12	130	165	200	3.5	M10	
TML 112	1-M25*1.5	180	215	250	4-15	4	110	130	160	M8	3.5	130	165	200	3.5	12	130	165	200	3.5	M10	



## TAI Series – Aluminium Three Phase

0.06kW to 37kW – Frame 56 to 200L



Techtop's TAI aluminium series motors are suitable for all industrial applications where optimal design performance and low weight are key factors.

### Operating parameters

Standard TAI series motors are designed with the following parameters:

- ⚡ 380V to 415V, 50Hz & 440V to 480V 60Hz supply
- ⚡ Continuous (S1) duty
- ⚡ Ambient temperatures up to 40°C
- ⚡ Installation up to 1000 MASL

### Connection

- ⚡ 230V Delta / 400V Star (3kW & below)
- ⚡ 400V Delta / 690V Star (4kW & above)

### Standards

Dimensions and rated outputs for the TAI series conform to Australian Standard AS/NZS 1359 and International Standards IEC 60034 and IEC 60072.

### Efficiency

The TAI range of motors complies with MEPS2 requirements of AS/NZS 1359.5:2004 with many ratings meeting High Efficiency levels of the same standard. TAI motors also meet European IE2 (High Efficiency) levels as set down in IEC 60034-30 international standards. Motors are tested in accordance with Test Method A of AS/NZS 1359.102.3 as per IEC 60034-2-1.

### Insulation class

TAI motors are insulated with Class F materials and limited to Class B temperature rise. The windings are spike resistant making them suitable for use with VVVF drives.

### Thermistors

As standard all TAI series motors from 160 frame and above are fitted with one set of PTC thermistors. The thermistor termination is located in the main terminal box and has a trip temperature of 150°C as standard. Additional 130°C thermistors can be fitted as an option for alarm connection. Thermistors are available as an option for smaller frame sizes.

### IP Protection

The standard degree of enclosure protection is IP 55 (increased IP protection is available). Shafts are fitted with an oil seal as standard on flange mount and a V ring seal on foot mount.

### Multi-mount design

As standard, TAI series motors are fitted with detachable feet. The multi-mount design allows for the motor feet to be removed and repositioned to either side to produce a side mounted terminal box.

Alternatively the feet can be removed and the motor mounted from any of the 16 mounting pads.

### Fan & Gearbox application

TAI series motors are low weight design and come standard with a drilled and tapped hole in the shaft which makes this series ideal for fan applications. This motor series is also ideally suited for fitting to aluminium gearboxes.

*\*Optional B5R flange is available for gearbox fitment – B5R flanges are one frame size smaller than standard B5 flanges.*

### Terminal box

The terminal box is manufactured from aluminium and is mounted on top of the motor as standard. Terminal box is separate to the motor body and can be rotated in 90° increments.



## Surface Finish

As standard TAI motors are painted with high quality alkyd enamel with the final colour being RAL 7024 Graphite Grey. Other colours are available upon request.

## Bearings

Bearings fitted are high quality NSK deep groove ball bearings that are sealed for life.

Frame Size	Bearing	
Aluminium	D.E.	N.D.E
56	6201 ZZ	
63	6202 ZZ	
71	6202 ZZ	
80	6204 ZZ	
90	6205 ZZ	
100	6206 ZZ	
112	6306 ZZ	6206 ZZ
132	6308 ZZ	6208 ZZ
160	6309 ZZ	6209 ZZ
180	6311 ZZ	6211 ZZ
200	6312 ZZ	6212 ZZ

## Conduit Entries

Frame Size	Entry Size	Number of Entries
56	M20 x 1.5	1
63	M20 x 1.5	1
71	M20 x 1.5	1
80	M25 x 1.5	2
90	M25 x 1.5	2
100	M20 x 1.5	2
112	M25 x 1.5	2
132	M25 x 1.5	2
160	M32 x 1.5	2
180	M32 x 1.5	2
200	M50 x 1.5	2

## Part Number Logic

Detailed below is the part number logic which should be specified when placing orders. The part number is composed in accordance with the following example:

T	A	4	B	0	2	2	5	TAI	B
1	2	3	4	5-7		8	9-11	12-14	

Position 1	Position 5 to 7	
T = Techtop	Output kW	
Position 2	Position 8	
A = Aluminium	Mounting position	
C = Cast iron	1 = V1	3 = B3
Position 3	4 = B3/5	5 = B5
2 = 2 Pole	6 = B3/B14A	7 = B14A
4 = 4 Pole	8 = B3/B14B	9 = B14B
6 = 6 Pole	A = B5R	B = B3/B5R
8 = 8 Pole	Position 9 to 11	
Position 4	TAI = Aluminium 3 PH	
A = less than 0.99kW	TCl = Cast iron 3 PH	
B = 1.0kW to 9.9kW	Position 12 to 14	
C = 10.0kW to 99.9kW	BHR = Brake motor with hand release	
D = 100kW to 999kW		

**TAI DATA**

Output kW	Full Load Speed [RPM]	Frame Size	Current @400v		Efficiency		Power Factor		Torque				Noise Level dB (A)	Weight Foot Mount [Kg]
			Full Load [A]	Locked Rotor [%]	Full Load [%]	3/4 Load [%]	Full Load [%]	3/4 Load [%]	Full Load [Nm]	Locked Rotor [% FLT]	Pull Up [% FLT]	Break Down [% FLT]		
0.06	1370	56A	0.30	314	50.9	46.6	0.56	0.48	0.42	320	302	319	56	2.9
0.09	2715	56A	0.32	329	53.5	49.6	0.76	0.65	0.32	228	212	239	58	2.6
	1375	56B	0.41	315	52.6	48.7	0.60	0.51	0.62	285	259	280	56	3.2
	840	63A	0.43	250	46.3	44.1	0.65	0.55	1.01	213	197	208	54	4.2
	665	71A	0.53	233	43.1	38.7	0.57	0.50	1.29	241	235	257	52	5.6
0.12	2700	56B	0.36	378	61.6	60.6	0.79	0.68	0.43	249	213	234	58	3.0
	1300	63A	0.51	292	54.6	52.1	0.62	0.52	0.88	302	272	279	55	3.7
	830	63B	0.56	237	48.0	46.5	0.65	0.55	1.38	219	190	205	54	4.5
	650	71B	0.62	259	47.7	44.5	0.59	0.50	1.75	252	247	262	52	6.0
0.18	2710	63A	0.55	375	60.7	58.6	0.78	0.66	0.63	244	207	236	58	4.0
	1275	63B	0.67	288	56.8	57.3	0.68	0.57	1.35	234	217	228	56	3.7
	880	71A	0.66	291	57.8	56.4	0.68	0.57	1.95	227	209	224	55	5.6
	690	80A	0.82	291	55.0	51.4	0.58	0.49	2.48	223	202	248	53	8.3
0.25	2715	63B	0.71	394	65.6	64.4	0.78	0.67	0.88	271	196	232	60	4.2
	1365	71A	0.75	388	63.0	61.7	0.76	0.68	1.74	205	184	224	58	5.0
	850	71B	0.84	293	59.7	61.2	0.72	0.61	2.79	195	187	205	56	6.0
	680	80B	1.05	307	58.7	55.6	0.58	0.49	3.46	230	207	248	54	9.3
0.37	2770	71A	1.04	503	62.8	60.5	0.82	0.73	1.28	288	188	257	61	5.2
	1370	71B	1.03	428	67.2	66.3	0.77	0.66	2.60	229	190	228	60	5.8
	900	80A	1.32	318	61.2	58.8	0.66	0.55	3.89	197	189	227	56	7.8
	700	90S	1.41	309	64.4	61.5	0.59	0.50	4.98	195	176	225	53	11.4
0.55	2800	71B	1.41	504	71.3	69.9	0.79	0.69	1.88	302	181	269	61	6.0
	1410	80A	1.63	449	71.5	70.1	0.68	0.58	3.72	233	190	259	59	8.3
	900	80B	1.85	346	65.8	64.4	0.65	0.54	5.79	217	198	234	58	9.1
	700	90L	2.1	338	65.3	62.9	0.58	0.49	7.46	195	179	235	57	13.9
0.75	2880	80A	1.76	687	80.1	80.2	0.79	0.71	2.5	292	196	302	64	9.5
	1420	80B	1.94	550	81.1	81.5	0.69	0.60	5.0	303	270	310	60	10.5
	940	90S	2.22	444	76.3	75.7	0.65	0.54	7.6	225	196	252	58	13.0
	690	100LA	2.21	363	72.3	73.3	0.68	0.58	10.4	177	175	213	55	21.0
1.1	2880	80A	2.39	758	81.2	81.3	0.82	0.74	3.6	283	186	285	64	10.4
	1420	90S	2.57	618	82.8	83.8	0.75	0.67	7.4	296	247	297	60	14.3
	950	90L	2.98	487	78.4	78.7	0.69	0.60	11.0	207	180	245	59	16.0
	690	100LA	3.17	390	74.8	75.2	0.67	0.57	15.1	198	192	230	55	25.0
1.5	2880	90S	3.19	690	83.1	83.5	0.83	0.75	5.0	276	187	308	68	13.5
	1440	90L	3.44	713	85.5	86.1	0.76	0.68	9.9	316	240	313	60	18.0
	945	100LA	3.71	472	80.1	82	0.74	0.66	15.1	172	161	225	59	20.0
	700	112M	4.18	403	78.4	79.3	0.68	0.59	20.4	182	180	212	55	25.4
2.2	2890	90L	4.61	811	84	84.4	0.83	0.75	7.2	300	222	318	68	16.2
	1440	100LA	4.55	726	85.8	86.6	0.82	0.76	14.6	260	218	305	62	23.4
	950	112M	5.36	547	82.8	83.9	0.73	0.64	22.0	220	181	271	59	26.3
	710	132S	5.95	420	80.0	80.6	0.67	0.58	29.4	186	174	233	55	44.0
3	2900	100L	5.59	920	87.0	87.6	0.90	0.87	9.9	309	249	351	71	22.3
	1445	100LB	6.27	760	86.0	86.6	0.80	0.73	19.8	239	244	325	62	26.3
	960	132S	6.42	601	85.5	86.6	0.76	0.70	29.6	188	157	258	63	43.0
	715	132M	7.8	529	82.7	83.1	0.70	0.61	39.9	231	203	274	58	51.0
4	2915	112M	7.56	960	87.4	87.7	0.89	0.84	13.1	332	208	365	71	28.7
	1440	112M	8.17	781	87.5	88.2	0.82	0.75	26.4	257	231	335	66	35.2
	960	132MA	9.21	583	84.7	85.6	0.74	0.68	39.6	200	165	257	63	52.0
	710	160MA	9.90	477	83.5	84.5	0.7	0.61	53.5	189	172	240	58	60.0
5.5	2910	132SA	10.3	823	87.8	88.3	0.89	0.85	18.0	244	195	343	75	45.4
	1460	132SA	11.0	856	88.1	88.5	0.83	0.77	35.9	217	193	350	67	49.4
	960	132MB	12.4	654	86.3	87.5	0.75	0.69	54.5	240	184	261	67	58.5
	715	160MB	13.3	505	85.1	86.1	0.7	0.62	73	209	185	263	64	82.0
7.5	2920	132SA	13.9	1029	89.2	89.6	0.89	0.86	24.5	314	202	366	75	50.0
	1450	132M	14.3	823	89.5	90.4	0.85	0.82	49.4	299	117	295	70	62.3
	960	160M	16.0	688	87.7	88.7	0.77	0.70	74.1	257	187	288	64	74.0
	710	160L	17.6	596	86.5	87.4	0.71	0.63	99.9	271	158	295	64	92.0
11	2945	160MA	19.7	831	90.5	90.6	0.89	0.86	35.6	267	152	345	79	79.0
	1460	160M	21.3	698	89.7	90.5	0.83	0.79	71.8	254	176	279	71	83.0
	970	160L	23.4	641	89.4	90.0	0.76	0.70	108.2	228	131	239	69	93.0
	730	180L	24.1	637	89.2	89.6	0.74	0.67	143.6	201	180	273	64	129.0
15	2950	160MB	26.0	939	92.5	92.7	0.90	0.86	48.5	260	186	343	79	91.0
	1460	160L	28.2	829	91.4	91.9	0.84	0.80	97.6	251	164	288	73	102.0
	975	180L	29.2	768	90.4	90.9	0.82	0.78	146.8	242	170	283	69	130.0
	730	200L	31.9	723	90.6	91.0	0.75	0.68	195.6	263	205	318	66	168.0
18.5	2950	160L	31.9	978	91.9	91.2	0.91	0.88	59.9	325	186	338	79	103.0
	1460	180M	33.2	774	91.5	91.9	0.88	0.83	120.4	238	185	298	73	119.0
	980	200LA	36.9	853	91.2	91.2	0.81	0.74	179.4	207	139	320	69	149.0
	22	2950	180M	39.5	865	92.3	92.6	0.87	0.85	71.2	274	160	316	84
	1460	180L	39.4	768	91.7	92.3	0.88	0.84	143.4	242	170	283	73	129.0
	980	200LB	42.6	1031	91.9	92.1	0.83	0.78	213.5	313	156	342	69	162.0
30	2955	200LA	52.9	703	92.0	92.3	0.90	0.88	96.9	205	104	254	86	158.0
	1470	200L	54.2	946	92.9	93.2	0.86	0.82	194.5	325	233	370	75	169.0
37	2950	200LA	63.7	954	92.1	91.8	0.91	0.89	119.5	287	134	348	86	182.0

**MOTOR OUTLINE DIMENSIONS**

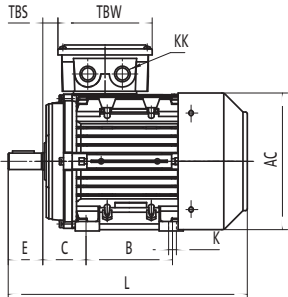

**B3**

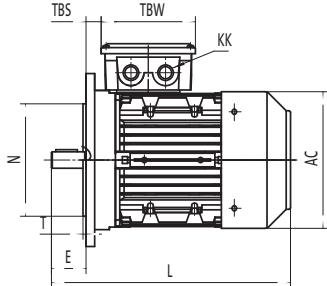
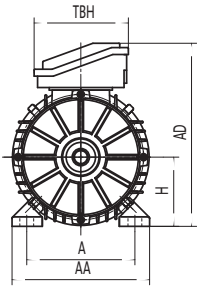

**B5**

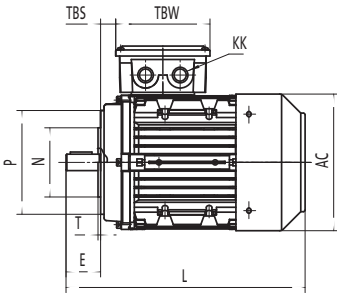
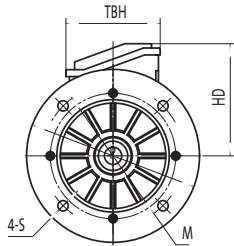

**B14**

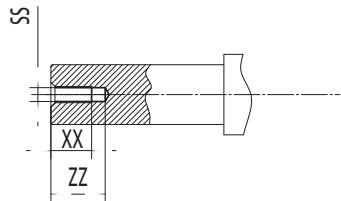
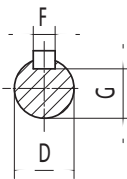
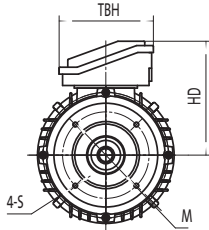

**SHAFT**

**TAI**

Frame Size	Foot Mounting					Shaft							General								
	H	A	B	C	D	E	F	G	K	SS	XX	ZZ	AA	AD	HD	AC	L	TBS	TBW	TBH	
TAI 56	56	90	71	36	9	20	3	7.2	6	M3	9	12	112	150	94	110	195	16.5	83	83	
TAI 63	63	100	80	40	11	23	4	8.5	7	M4	10	14	124	169	106	122	215	10	98	98	
TAI 71	71	112	90	45	14	30	5	11	7	M5	12	17	140	185	114	138	245	16	98	98	
TAI 80	80	125	100	50	19	40	6	15.5	9	M6	16	21	160	214	134	158	280	18.5	109	109	
TAI 90S/L	90	140	100/125	56	24	50	8	20	10	M8	19	25	175	233	143	177	315/340	20.5	109	109	
TAI 100L	100	160	140	63	28	60	8	24	12	M10	22	30	200	260	160	200	377	29	118	118	
TAI 112M	112	190	140	70	28	60	8	24	12	M10	22	30	230	283	171	220	400	30	118	118	
TAI 132S/M	132	216	140/178	89	38	80	10	33	12	M12	28	37	255	322	190	261	460/498	34	118	118	
TAI 160M/L	160	254	210/254	108	42	110	12	37	15	M16	36	45	314	391	231	313	616/662	64	148	148	
TAI 180M/L	180	279	241/279	121	48	110	14	42.5	15	M16	36	45	340	440	260	368	730	73	190	190	
TAI 200L	200	318	305	133	55	110	16	49	19	M20	42	53	390	460	260	368	745	85	190	190	

Frame Size	B5					B14A					B5R					B14B				
	N	M	P	S	T	N	M	P	S	T	N	M	P	T	S	N	M	P	T	S
TAI 56	80	100	120	4-7	3	50	65	80	M5	2.5										
TAI 63	95	115	140	4-10	3	60	75	90	M5	2.5										
TAI 71	110	130	160	4-10	3.5	70	85	105	M6	2.5	95	115	140	3	10	95	115	140	3	M8
TAI 80	130	165	200	4-12	3.5	80	100	120	M6	3	110	130	160	3.5	10	110	130	160	3.5	M8
TAI 90	130	165	200	4-12	3.5	95	115	140	M8	3	110	130	160	3.5	10	110	130	160	3.5	M8
TAI 100	180	215	250	4-15	4	110	130	160	M8	3.5	130	165	200	3.5	12	130	165	200	3.5	M10
TAI 112	180	215	250	4-15	4	110	130	160	M8	3.5	130	165	200	3.5	12	130	165	200	3.5	M10
TAI 132	230	265	300	4-15	4	130	165	200	M10	3.5	180	215	250	4	15	180	215	250	4	M12
TAI 160	250	300	350	4-19	5	180	215	250	M12	4										
TAI 180	250	300	350	4-19	5															
TAI 200	300	350	400	4-19	5															

## TAIB Brake Motors

0.37kW to 7.5kW



Based on our standard TAI range the TAIB series is stocked from 0.37kW to 7.5kW in 4 pole only with larger ratings and polarities available upon request.

### Fail Safe Design

TAIB brake motors are fitted with Intorq brand brakes and are “fail to safe” design, as the brake will engage when the power is disconnected.

### Brake Connection

The TAIB three phase motor is fitted with a DC brake and half wave rectifier mounted directly in the terminal box for ease of connection to the AC supply.

### Hand Release

As standard, all TAIB brake motors are fitted with an emergency hand release.

### Mounting Arrangements

TAIB motors are available in identical mounting arrangements to that of our standard TAI aluminium series.

## Brake Motor Data

kW	Frame Size	Intorq Brake Model	Braking Torque (Nm)	Holding Torque (Nm)	Braking Torque (%) of full load torque	Braking Time (ms)	Release Time (ms)
0.37	71B-4	BFK-457-06	4	6	154%	19	37
0.55	80A-4	BFK-457-08	8	12	216%	35	42
0.75	80B-4	BFK-457-08	8	12	160%	35	42
1.1	90S-4	BFK-457-10	16	23	216%	60	100
1.5	90L-4	BFK-457-10	16	23	162%	60	100
2.2	100LA-4	BFK-457-12	32	46	219%	53	135
3	100LB-4	BFK-457-12	32	46	162%	53	135
4	112M-4	BFK-457-14	60	95	227%	57	240
5.5	132S-4	BFK-457-16	80	125	223%	50	275
7.5	132M-4	BFK-457-16	80	125	162%	50	275



### MOTOR OUTLINE DIMENSIONS

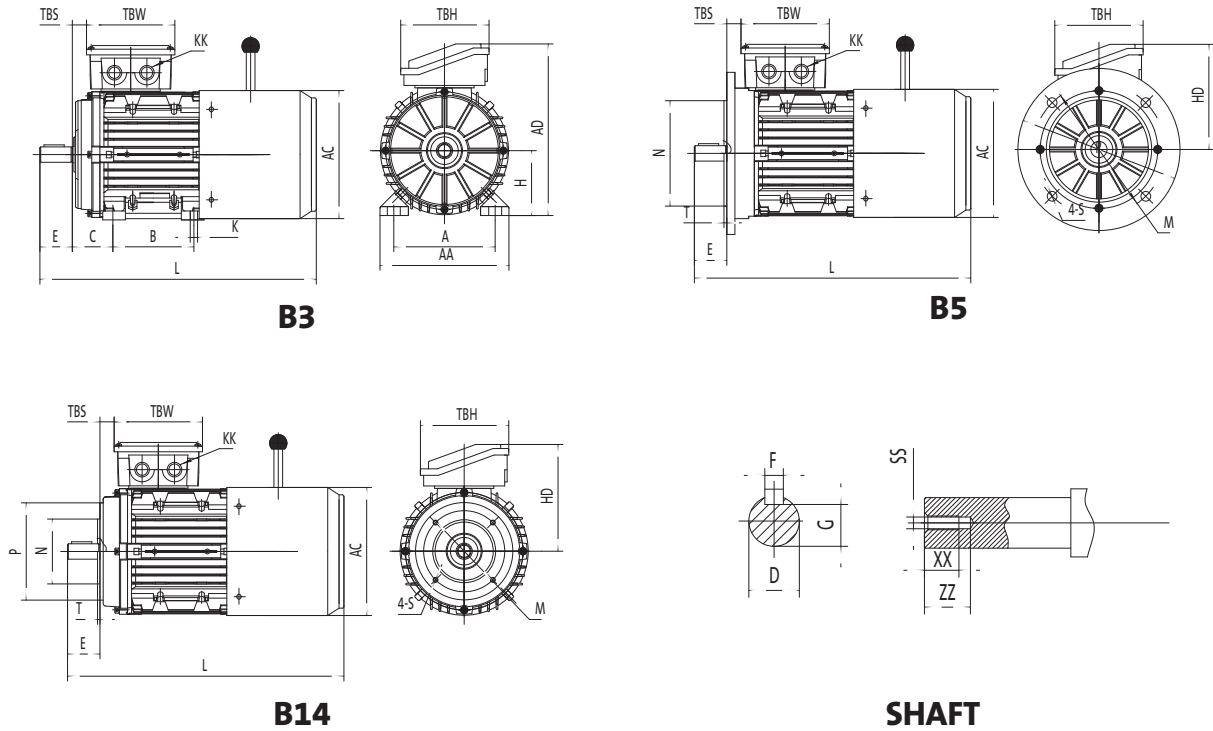

### TAIB

Frame Size	Foot Mounting				Shaft								General							
	H	A	B	C	D	E	F	G	K	SS	XX	ZZ	AA	AD	HD	AC	L	TBS	TBW	TBH
TAIB 80	80	125	100	50	19	40	6	15.5	9	M6	16	21	160	214	134	158	341	18.5	109	109
TAIB 90S/L	90	140	100/125	56	24	50	8	20	10	M8	19	25	175	233	143	177	366/391	20.5	109	109
TAIB 100L	100	160	140	63	28	60	8	24	12	M10	22	30	200	260	160	200	440	29	118	118
TAIB 112M	112	190	140	70	28	60	8	24	12	M10	22	30	230	283	171	220	465	30	118	118
TAIB 132S/M	132	216	140/178	89	38	80	10	33	12	M12	28	37	255	322	190	261	543/581	34	118	118

Frame Size	B5					B14A					B5R					B14B				
	N	M	P	S	T	N	M	P	S	T	N	M	P	T	S	N	M	P	T	S
TAIB 80	130	165	200	4-12	3.5	80	100	120	M6	3	110	130	160	3.5	10	110	130	160	3.5	M8
TAIB 90S/L	130	165	200	4-12	3.5	95	115	140	M8	3	110	130	160	3.5	10	110	130	160	3.5	M8
TAIB 100L	180	215	250	4-15	4	110	130	160	M8	3.5	130	165	200	3.5	12	130	165	200	3.5	M10
TAIB 112M	180	215	250	4-15	4	110	130	160	M8	3.5	130	165	200	3.5	12	130	165	200	3.5	M10
TAIB 132S/M	230	265	300	4-15	4	130	165	200	M10	3.5	180	215	250	4	15	180	215	250	4	M12

## TCI Series – Cast Iron Three Phase

0.75kW to 315kW – Frame 80 to 355

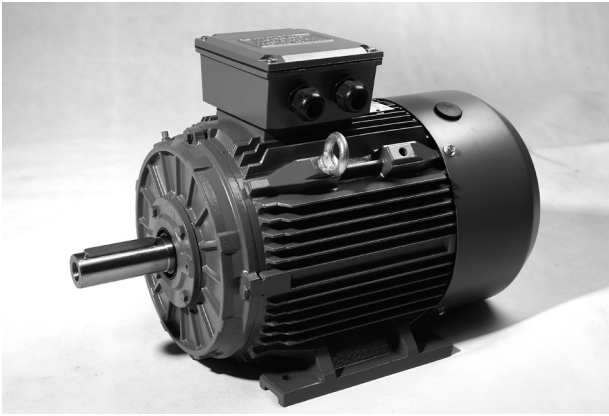

Techtop's TCI cast iron series motors combine superior electrical characteristics, high quality design and the robust strength of cast iron, making this series ideal for all industrial applications.

### Operating parameters

Standard TCI series motors are designed with the following parameters:

- ⚡ 380V to 415V, 50Hz & 440V to 480V 60Hz supply
- ⚡ Continuous (S1) duty
- ⚡ Ambient temperatures up to 40°C
- ⚡ Installation up to 1000 MASL

### Connection

- ⚡ 230V Delta / 400V Star (3kW & below)
- ⚡ 400V Delta / 690V Star (4kW & above)

### Standards

Dimensions and rated outputs for the TCI series conform to Australian Standard AS/NZS 1359 and International Standards IEC 60034 and IEC 60072.

### Efficiency

The TCI range of motors complies with MEPS2 requirements of AS/NZS 1359.5:2004 with many ratings meeting High Efficiency levels of the same standard. TCI motors also meet European IE2 (High Efficiency) levels as set down in IEC 60034-30 international standards. Motors are tested in accordance with Test Method A of AS/NZS 1359.102.3 as per IEC 60034-2-1.

### Insulation class

TCI motors are insulated with Class F materials and limited to Class B temperature rise. The windings are spike resistant making them suitable for use with VVVF drives.

### Thermistors

As standard all TCI series motors from 160 frame and above are fitted with one set of PTC thermistors. The thermistor termination is located in the main terminal box and has a trip temperature of 150°C as standard. Additional 130°C thermistors can be fitted as an option for alarm connection. Thermistors are available as an option for smaller frame sizes.

### IP Protection

The standard degree of enclosure protection is IP 55 (increased IP protection is available). Shafts are fitted with an oil seal as standard.

### Multi-mount design

TCI series motors from frame size 80 to 280 are fitted with detachable feet. The multi-mount design allows for the motor feet to be removed and repositioned to either side to produce a side mounted terminal box.

### Terminal box

The terminal box is manufactured from cast iron and is mounted on top of the motor as standard. Terminal box is separate to the motor body and can be rotated in 90° increments.

### Surface Finish

As standard TCI motors are painted with high quality alkyd enamel with the final colour being RAL 7024 Graphite Grey. Other colours are available upon request.

## Radial and Axial Loads

The table below details the permissible force that can be applied to the motor shaft and are applicable for horizontal mounting only.

The values shown are calculated on a basic bearing life of L10 of 40,000 hours.

Frame Size	Permissible Radial Load (N)				Permissible Axial Load (N)			
	2 Pole	4 Pole	6 Pole	8 Pole	2 Pole	4 Pole	6 Pole	8 Pole
80	470	595	690	750	395	540	655	635
90	485	625	720	785	420	570	685	690
100	710	890	1035	1150	570	780	940	1075
112	950	1240	1420	1580	790	1085	1310	1520
132	1420	1820	2100	2325	1160	1590	1915	2210
160	1800	2350	2720	3040	1480	2035	2450	2810
180	2490	3200	3780	4215	1990	2710	3270	3760
200	2915	3750	4350	4835	2225	3065	3710	4235
225	3270	4000	4700	5210	2460	3390	4130	4750
250	3590	4650	5400	5980	2725	3780	4575	5225
280	3700	8100	9375	10300	3280	4560	5590	6375
315 (2P)	4500	-	-	-	3825	-	-	-
315 (4/6/8)	-	15800	17950	19750	-	4855	5895	6780
355 (2P)	4560	-	-	-	3980	-	-	-
355 (4/6/8)	-	22145	25360	27890	-	6135	7395	8555

## Grease

TCI bearings are lubricated with lithium based bearing grease suitable for operation in ambient temperatures from -20°C to +55°C.

Bearings are prepacked with grease but it is recommended to lubricate the bearings one hour after commissioning.

## Recommended Bearing Maintenance

Frame Size	Bearing	Grease	Interval Hours			
		Qty (g)	2P	4P	6P	8P
160	6309 C3	15	6600	11000	14000	16200
180	6311 C3	18	6100	10600	14000	15250
200	6312 C3	20	5200	10200	14100	15000
225	6313 C3	25	4900	9600	13600	15000
250	6314 C3	38	2600	9200	13200	14600
280	6316 C3	42	2100	9000	12800	14000
315 (2P)	6317 C3	44	2000	-	-	-
315 (4/6/8)	NU/6319 C3	48	-	6400	9300	12000
355 (2P)	6319 C3	48	1900	-	-	-
355 (4/6/8)	NU/6322 C3	68	-	4400	8300	11000

### Bearings

Bearings fitted are high quality NSK bearings with C3 diametrical clearances. As standard, frame sizes 80 to 132 have sealed for life deep groove ball bearings. Frame sizes 160 to 355 have regreasable bearings with facilities to replenish the grease during operation. Grease nipples are fitted to the top of the end shields with a grease relief fitted at the bottom.

### Bearing Size

Frame Size	Bearing	
	Cast Iron	N.D.E
80	6204 ZZ C3	
90	6205 ZZ C3	
100	6206 ZZ C3	
112	6306 ZZ C3	
132	6308 ZZ C3	
160	6309 C3	
180	6311 C3	
200	6312 C3	
225	6313 C3	
250	6314 C3	
280	6316 C3	
315 (2P)	6317 C3	
315 (4/6/8)	NU319 C3	6319 C3
355 (2P)	6319 C3	
355 (4/6/8)	NU322 C3	6322 C3

### Vibration

Vibration levels are within Level N (normal) limits of vibration severity as per IEC 60034 – 14:1996 and AS 1359.114 which are listed below:

Frame Size	Maximum vibration (mm/sec)
80-132	1.8
160-225	2.8
250-355	3.5

### Noise Level

Noise levels comply with the limits shown in IEC 60034.9 and AS1359.109 standards. TCI sound pressure levels are shown in the technical data on pages 17 and 18 of this catalogue.

### Conduit Entries

Frame Size	Entry Size	Number of Entries
80	M20 x 1.5	2
90	M20 x 1.5	2
100	M20 x 1.5	2
112	M25 x 1.5	2
132	M25 x 1.5	2
160*	M32 x 1.5	2
180*	M32 x 1.5	2
200*	M50 x 1.5	2
225*	M50 x 1.5	2
250*	M50 x 1.5	2
280*	M50 x 1.5	2
315*	M63 x 1.5	2
355*	M63 x 1.5	2

\*Frames fitted with 1 X M20 cable gland for thermistor termination.

### Part Number Logic

Detailed below is the part number logic which should be specified when placing orders. The part number is composed in accordance with the following example:

<b>T</b>	<b>A</b>	<b>4</b>	<b>B</b>	<b>0</b>	<b>2</b>	<b>2</b>	<b>5</b>	<b>TAI</b>	<b>B</b>
1	2	3	4		5-7		8	9-11	12-14

<b>Position 1</b>	<b>Position 5 to 7</b>	
T = Techtop	Output kW	
<b>Position 2</b>	<b>Position 8</b>	
A = Aluminium	Mounting position	
C = Cast iron	1 = V1	3 = B3
<b>Position 3</b>	4 = B3/5	5 = B5
2 = 2 Pole	6 = B3/B14A	7 = B14A
4 = 4 Pole	8 = B3/B14B	9 = B14B
6 = 6 Pole	A = B5R	B = B3/B5R
8 = 8 Pole	<b>Position 9 to 11</b>	
<b>Position 4</b>	TAI = Aluminium 3 PH	
A = less than 0.99kW	TCI = Cast iron 3 PH	
B = 1.0kW to 9.9kW	Position 12 to 14	
C = 10.0kW to 99.9kW	BHR = Brake motor with hand release	
D = 100kW to 999kW		





















## TCI Data

Output kW	Full Load Speed [RPM]	Frame Size	Shaft Dia [mm]	Current @400v		Efficiency		Power Factor		Torque				Noise Level dB (A)	Weight Foot Mount [Kg]
				Current Full Load [A]	Locked Rotor [%]	Full Load [%]	3/4 Load [%]	Full Load [%]	3/4 Load [%]	Full Load [Nm]	Locked Rotor [%FLT]	Pull Up [%FLT]	Break Down [%FLT]		
0.75	2880	80A	19	1.76	687	80.1	80.2	0.79	0.71	2.5	292	196	302	64	16
	1420	80B	19	1.94	550	81.1	81.5	0.69	0.60	5	303	270	310	60	18
	940	90S	24	2.22	444	76.3	75.7	0.65	0.54	7.6	225	196	252	58	20
	690	100LA	28	2.21	363	72.3	73.3	0.68	0.58	10.4	177	175	213	55	34
1.1	2880	80A	19	2.39	758	81.2	81.3	0.82	0.74	3.6	283	186	285	64	17
	1420	90S	24	2.57	618	82.8	83.8	0.75	0.67	7.4	296	247	297	60	22
	950	90L	24	2.98	487	78.4	78.7	0.69	0.60	11	207	180	245	59	29
	690	100LA	28	3.17	390	74.8	75.2	0.67	0.57	15.1	198	192	230	55	35
1.5	2880	90S	24	3.19	690	83.1	83.5	0.83	0.75	5.0	276	187	308	68	21
	1440	90L	24	3.44	713	85.5	86.1	0.76	0.68	9.9	316	240	313	60	26
	945	100LA	28	3.71	472	80.1	82	0.74	0.66	15.1	172	161	225	59	34
	700	112M	28	4.18	403	78.4	79.3	0.68	0.59	20.4	182	180	212	55	42
2.2	2890	90L	24	4.61	811	84	84.4	0.83	0.75	7.2	300	222	318	68	22
	1440	100LA	28	4.55	726	85.8	86.6	0.82	0.76	14.6	260	218	305	62	36
	950	112M	28	5.36	547	82.8	83.9	0.73	0.64	22	220	181	271	59	40
	710	132S	38	5.95	420	80.0	80.6	0.67	0.58	29.4	186	174	233	55	68
3	2900	100L	28	5.59	920	87.0	87.6	0.90	0.87	9.9	309	249	351	71	35
	1445	100LB	28	6.27	760	86.0	86.6	0.80	0.73	19.8	239	244	325	62	37
	960	132S	38	6.42	601	85.5	86.6	0.76	0.70	29.6	188	157	258	63	65
	715	132M	38	7.8	529	82.7	83.1	0.70	0.61	39.9	231	203	274	58	77
4	2915	112M	28	7.56	960	87.4	87.7	0.89	0.84	13.1	332	208	365	71	47
	1440	112M	28	8.17	781	87.5	88.2	0.82	0.75	26.4	257	231	335	66	51
	960	132MA	38	9.21	583	84.7	85.6	0.74	0.68	39.6	200	165	257	63	67
	720	160MA	42	10.8	600	84.2	84.0	0.63	0.58	53.8	250	200	280	58	116
5.5	2910	132SA	38	10.3	823	87.8	88.3	0.89	0.85	18	244	195	343	75	61
	1460	132SA	38	11.0	856	88.1	88.5	0.83	0.77	35.9	217	193	350	67	65
	960	132MB	38	12.4	654	86.3	87.5	0.75	0.69	54.5	240	184	261	67	68
	720	160MB	42	14.9	600	85.8	84.7	0.63	0.61	74.0	230	190	260	64	147
7.5	2920	132SA	38	13.9	1029	89.2	89.6	0.89	0.86	24.5	314	202	366	75	66
	1450	132M	38	14.3	823	89.5	90.4	0.85	0.82	49.4	299	117	295	70	77
	980	160M	42	17.5	855	89.7	89.4	0.71	0.63	73.0	331	194	336	67	122
	720	160L	42	18.6	600	87.2	86.9	0.67	0.64	100.1	240	190	270	64	147
11	2950	160MA	42	19.5	858	89.9	90.2	0.91	0.89	35.6	260	93	302	79	115
	1470	160MA	42	20.4	838	91.7	91.7	0.86	0.81	71.3	287	203	329	71	127
	975	160L	42	23.8	818	89.4	89.7	0.75	0.68	107.5	309	140	152	70	146
	730	180L	48	23.8	660	88.8	88.7	0.75	0.69	145.9	230	200	280	64	183
15	2950	160MB	42	26.2	901	91.8	92.1	0.92	0.9	48.4	257	132	316	79	148
	1470	160L	42	27.4	881	91.1	91.5	0.88	0.84	97.4	253	177	316	73	142
	980	180L	48	31.4	882	89.6	88.9	0.77	0.70	145.7	267	153	322	69	185
	730	200L	55	30.6	660	90.0	90.1	0.78	0.76	198.9	220	200	290	66	240
18.5	2950	160L	42	32.0	976	92.1	92.6	0.92	0.91	59.8	302	140	332	79	174
	1470	180M	48	33.2	786	91.8	92	0.88	0.84	120.1	254	194	311	73	158
	980	200LA	55	36.9	853	91.2	91.2	0.81	0.74	179.4	207	139	320	69	232
	730	225S	60	38.7	660	90.7	90.4	0.76	0.72	243.7	220	200	320	66	315
22	2950	180L	48	39.1	843	91.2	91	0.90	0.88	71.2	266	163	330	84	177
	1465	180L	48	38.9	767	91.9	92.5	0.89	0.86	143.1	225	155	269	73	183
	980	200LB	55	42.6	1031	91.9	92.1	0.83	0.78	213.5	313	156	342	69	250
	740	225M	60	43.5	660	91.2	91.4	0.80	0.78	289.7	210	190	310	67	348
30	2955	200LA	55	52.9	703	92.0	92.3	0.90	0.88	96.9	205	104	254	86	233
	1480	200LA	55	57.2	814	92.5	92.7	0.82	0.76	193.5	237	191	295	75	242
	985	225M	60	54.9	815	91.9	92.4	0.86	0.83	290.5	264	151	257	72	335
	740	250M	65	61.5	660	92.1	91.6	0.76	0.71	392.4	210	190	270	69	397
37	2955	200LA	55	64.9	759	92.7	93.1	0.90	0.88	119.6	244	144	260	86	246
	1475	225S	60	65.4	743	92.8	93.4	0.89	0.87	239.1	222	147	243	75	315
	980	250M	65	68.7	646	93.2	93.3	0.85	0.82	359.2	186	135	232	72	398
	740	280S	75	73.5	660	92.7	92.5	0.78	0.74	484.0	210	180	250	69	500
45	2955	225M	55	77.6	744	93.2	93.4	0.91	0.89	145.2	273	113	251	88	322
	1475	225M	60	85.1	695	93.1	92.9	0.83	0.78	290.5	207	187	333	75	352
	985	280S	75	81.5	850	92.7	93.0	0.86	0.82	434.7	284	156	272	75	505
	740	280M	75	88.9	660	93.2	93.1	0.78	0.77	584.7	200	180	250	69	594

**TCI Data continued**

Output kW	Full Load Speed [RPM]	Frame Size	Shaft Dia [mm]	Current @400v		Efficiency		Power Factor		Torque				Noise Level dB (A)	Weight Foot Mount [Kg]
				Current Full Load [A]	Locked Rotor [%]	Full Load [%]	3/4 Load [%]	Full Load [%]	3/4 Load [%]	Full Load [Nm]	Locked Rotor [%FLT]	Pull Up [%FLT]	Break Down [%FLT]		
55	2970	250M	60	93.3	892	94.5	94.3	0.91	0.90	176.8	302	142	299	88	420
	1480	250M	65	98.7	805	93.6	93.9	0.86	0.83	354.4	264	167	268	77	420
	985	280M	75	99.0	897	93.5	93.6	0.87	0.83	531.3	321	181	311	75	596
	740	315S	80	107.2	750	93.7	93.1	0.79	0.76	709.8	200	180	240	73	1025
75	2970	280S	65	125.3	898	93.9	93.9	0.93	0.93	241.0	256	105	281	90	572
	1480	280S	75	127.7	756	94.9	95.2	0.90	0.89	482.5	254	211	237	80	570
	980	315S	80	128.9	790	94.4	94.1	0.89	0.86	730.8	210	190	250	77	809
	740	315M	80	145.2	770	94.4	94.0	0.79	0.75	967.8	200	180	230	75	1108
90	2970	280M	65	148.3	1009	94.5	94.3	0.93	0.92	289.1	294	123	302	90	637
	1485	280M	75	152.9	860	94.4	94.8	0.92	0.90	578.7	297	229	260	80	658
	980	315M	80	152.3	800	94.8	94.2	0.90	0.88	877.0	200	180	230	77	962
	740	315LA	80	171.5	780	94.7	94.5	0.80	0.78	1161.4	200	180	220	75	1155
110	2980	315S	65	185.5	770	95.1	95.2	0.90	0.88	357.3	190	170	225	91	1008
	1485	315S	80	185.1	780	95.3	95.1	0.91	0.89	709.8	210	180	230	83	1049
	980	315LA	80	185.5	770	95.1	95.3	0.90	0.87	1071.9	200	180	235	78	989
132	2980	315M	65	219.5	760	95.4	95.2	0.91	0.89	428.7	190	160	220	91	1062
	1485	315M	80	219.2	780	95.5	95.2	0.91	0.90	851.7	210	190	240	85	1108
	980	315LB	80	224.4	800	95.4	95.1	0.89	0.87	1286.2	200	175	230	79	1082
160	2980	315LA	65	268.7	780	95.5	95.4	0.90	0.90	518.8	205	180	240	91	1222
	1485	315LA	80	265.2	790	95.7	95.5	0.91	0.91	1032.4	200	180	230	86	1222
	985	355MA	100	265.5	760	95.6	95.3	0.91	0.89	1559.0	220	195	238	84	1580
	745	355MB	100	287.3	780	95.7	95.4	0.84	0.82	2050.9	200	180	235	81	1740
200	2985	315LB	65	339.7	790	95.5	95.2	0.89	0.88	648.5	215	170	240	91	1240
	1490	315LB	80	335.2	770	95.7	95.6	0.90	0.90	1290.5	200	180	235	88	1190
	985	355MB	100	336.0	760	95.6	95.7	0.90	0.88	1948.8	210	190	245	84	1760
	745	355LB	100	350.8	770	95.7	95.5	0.86	0.85	2563.6	205	185	235	81	1990
250	2985	355M	75	419.8	780	95.5	95.2	0.90	0.89	810.6	200	180	240	94	1780
	1490	355M	100	423.7	790	95.7	95.4	0.89	0.87	1613.0	230	190	260	91	1820
	985	355LB	100	424.1	780	95.6	95.2	0.89	0.86	2436.0	210	190	250	87	1990
315	2985	355LB	75	535.0	740	95.5	95.6	0.89	0.86	1021.4	225	195	240	94	1900
	1490	355LB	100	527.9	755	95.7	95.4	0.90	0.88	2032.5	230	185	255	91	1955

Mounting Arrangements												
Frame Size	B3	B5	B3/B5	V1	V3	V5	V6	B6	B7	B8	V1/V5	V3/V6
												
56-200	✓	✓	✓	✓	✓	✓	✓	✓	✓	✓	✓	✓
225-250	✓	✓	✓	✓	-	-	-	-	-	-	-	-
280-355	✓	-	✓	✓	-	-	-	-	-	-	-	-
Frame Size	B14	B3/B14	V18	V19	V5/V18	V6/V19						
												
56-160	✓	✓	✓	✓	✓	✓						

Maximum starting time (seconds)					
Frame Size	Method	2 Pole	4 Pole	6 Pole	8 Pole
56-71	D.O.L	20	28	44	-
80	D.O.L	15	26	40	40
90	D.O.L	10	15	25	30
100	D.O.L	12	14	18	40
112	D.O.L	10	10	18	35
132	D.O.L	14	12	12	25
160-315	D.O.L	15	15	20	22
355	Star-Delta	45	45	60	65

Starts per hour				
Frame Size	2 Pole	4 Pole	6 Pole	8 Pole
56-71	22	40	40	-
80-90	18	35	40	40
100-132	12	22	25	25
160-180	10	18	22	22
200	6	12	12	12
225	5	10	10	10
250	4	8	8	8
280	3	6	6	8
315	3	4	6	6
355	2	3	3	3

**MOTOR OUTLINE DIMENSIONS**

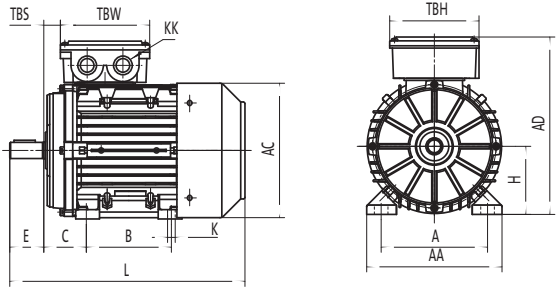

**B3**

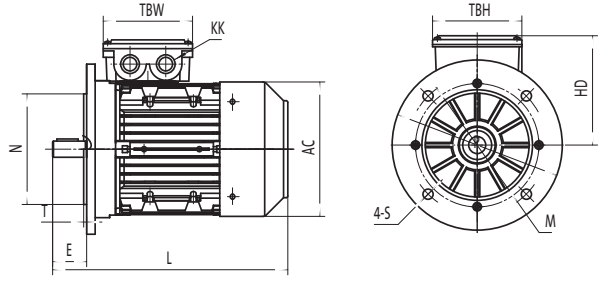

**B5**

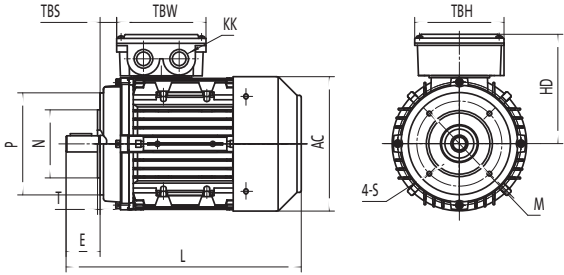

**B14**

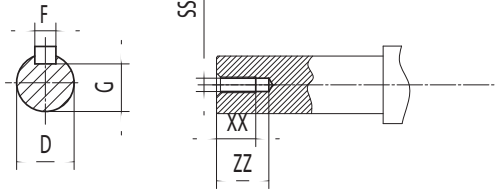

**SHAFT**

Frame Size	Foot Mounting				Shaft					General								
	H	A	B	C	D	E	F	G	K	AA	AD	HD	AC	L	TBS	TBW	TBH	
80	80	125	100	50	19	40	6	15.5	9	154	209	129	158	290	48	105	105	
90S/L	90	140	100/125	56	24	50	8	20	10	178	231	150	176	320/345	49	114	114	
100	100	160	140	63	28	60	8	24	12	203	251	151	199	385	76	114	114	
112	112	190	140	70	28	60	8	24	12	231	292	180	220	405	73	134	134	
132S/M	132	216	140/178	89	38	80	10	33	12	264	330	198	259	457/505	62	134	134	
160M/L	160	254	210/254	108	42	110	12	37	15	316	404	244	313	605/650	91	162	162	
180M/L	180	279	241/279	121	48	110	14	42.5	15	361	442	262	360	687/725	160/180	162	187	
200L	200	318	305	133	55	110	16	49	19	392	500	300	399	769	193	186	233	
225S	4,8	225	356	286	149	60	140	18	53	19	438	557	332	465	810	199	186	233
225M	2	225	356	311	149	55	110	16	49	19	438	557	332	465	805	212	186	233
	4,6,8	225	356	311	149	60	140	18	53	19	438	557	332	465	835	212	186	233
250M	2	250	406	349	168	60	140	18	53	24	484	616	366	506	915	234	218	260
	4,6,8	250	406	349	168	65	140	18	58	24	484	616	366	506	915	234	218	260
280S/M	2	280	457	368/419	190	65	140	18	58	24	557	673/690	393/410	559	984/1035	265/277	218/245	260/280
	4,6,8	280	457	368/419	190	75	140	20	67.5	24	557	673/690	393/410	559	984/1035	265/277	218/245	260/280
315S	2	315	508	406	216	65	140	18	58	28	628	825	510	682	1205	200	290	350
	4,6,8	315	508	406	216	80	170	22	71	28	628	825	510	682	1235	200	290	350
315M/L	2	315	508	457/508	216	65	140	18	58	28	628	825	510	682	1355	200	290	350
	4,6,8	315	508	457/508	216	80	170	22	71	28	628	825	510	682	1385	200	290	350
355M/L	2	355	610	560/630	254	75	140	20	67.5	28	740	1010	655	820	1500	140	330	380
	4,6,8	355	610	560/630	254	100	210	28	90	28	740	1010	655	820	1570	140	330	380

Frame Size	B5					Frame Size	B14A				
	N	M	P	S	T		N	M	P	S	T
80-90	130	165	198	4-12	3.5	80	80	100	118	M6	3
100-112	180	215	250	4-15	4	90	95	115	138	M8	3
132	230	265	300	4-15	4	100-112	110	130	158	M8	3.5
160-180	250	300	350	4-19	5	132	130	165	198	M10	3.5
200	300	350	400	4-19	5						
225	350	400	450	8-19	5						
250-280	450	500	550	8-19	5						
315	550	600	660	8-24	6						
355	680	740	800	8-24	6						



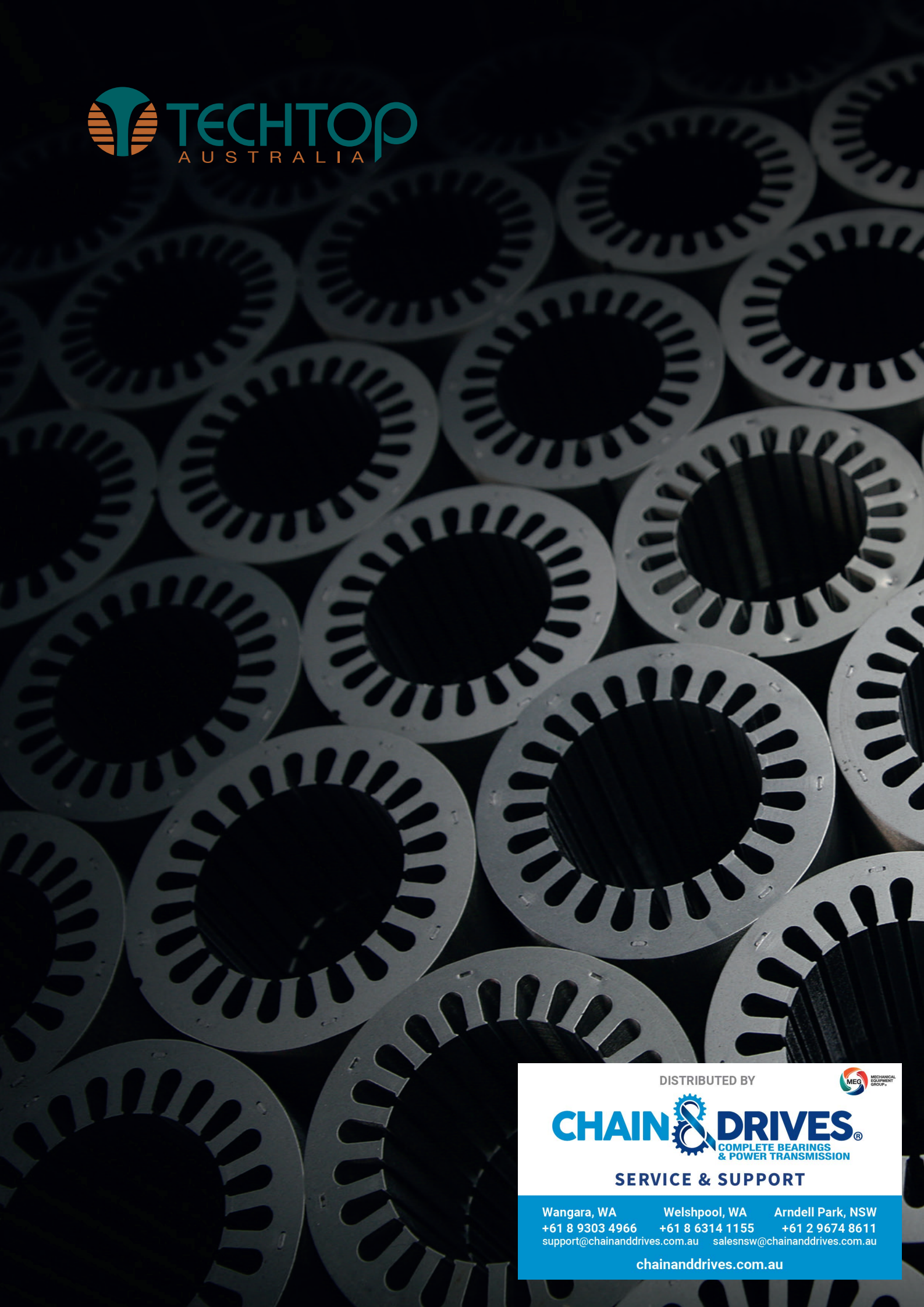

DISTRIBUTED BY



**CHAIN & DRIVES**<sup>®</sup>  
COMPLETE BEARINGS  
& POWER TRANSMISSION

**SERVICE & SUPPORT**

Wangara, WA      Welshpool, WA      Arndell Park, NSW  
+61 8 9303 4966    +61 8 6314 1155    +61 2 9674 8611  
support@chainanddrives.com.au    salesnsw@chainanddrives.com.au

[chainanddrives.com.au](http://chainanddrives.com.au)