

CHAIN & DRIVES®

√VARIACTO®

AKTIVIERT DEN ERFINDERGEIST

iwis

wir bewegen die welt

iwis antriebssysteme



www.variacto.com

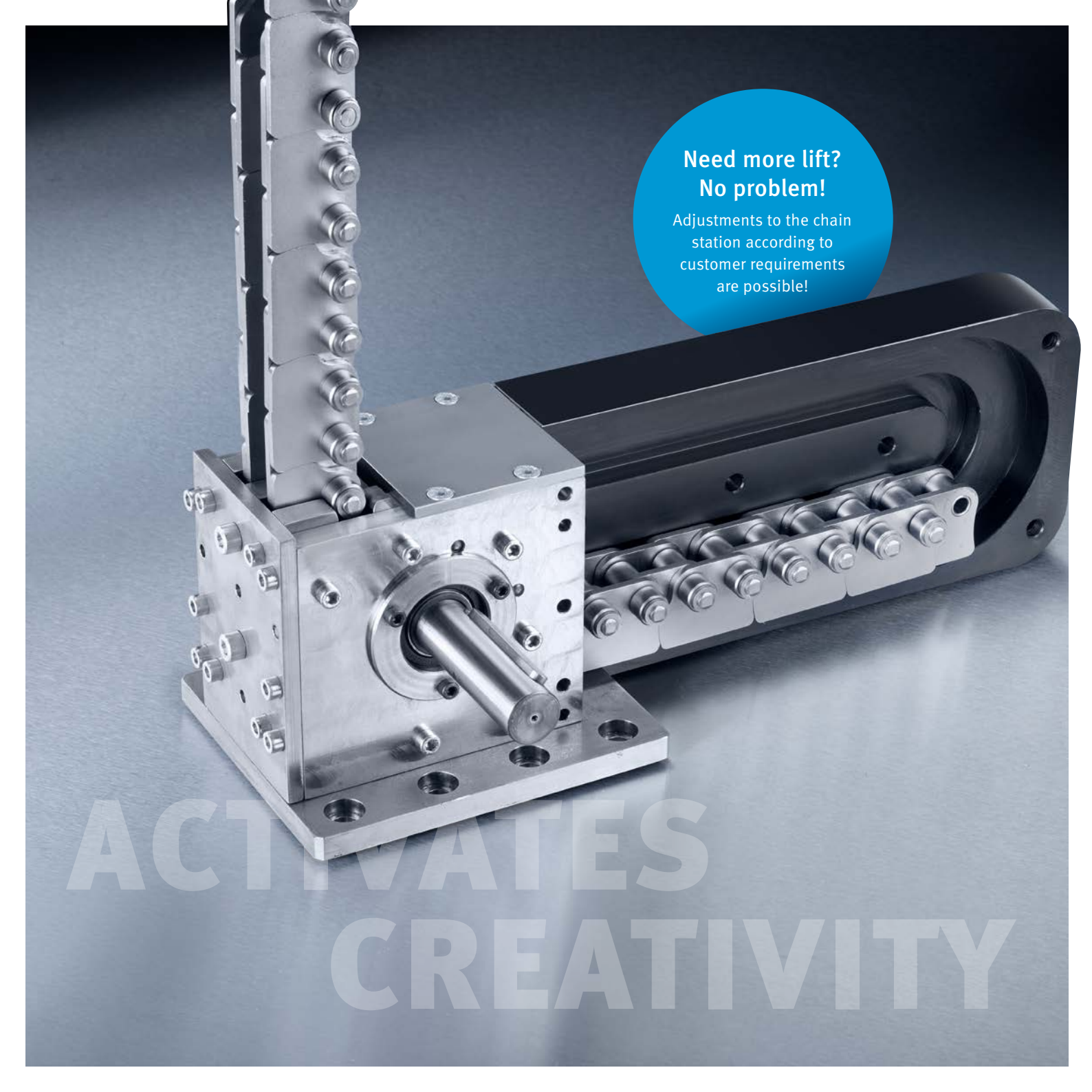

**Need more lift?
No problem!**

Adjustments to the chain
station according to
customer requirements
are possible!

**ACTIVATES
CREATIVITY**

Pioneering in Drive Technology

With **VARIACTO**[®], entirely new solution approaches arise. With this unique push-pull chain drive, you achieve more goals than before – pushing farther and higher. Change the drive type with **VARIACTO**[®] and optimize the use of space in your system layout. **VARIACTO**[®] opens up numerous new possibilities, whether in vertical or horizontal thrust. Thanks to its flexible use, **VARIACTO**[®] outperforms conventional linear drives.



Minimal Space Requirement

With **VARIACTO**[®], you only need minimal space. The low housing height and the redirection of the chain by 90° in the drive unit or 180° in the chain station enable uniquely flat designs and open up new possibilities in construction. With the minimal height of the drive, you can still move heavy loads over long distances. Unlike traditional linear drives, the space of the drive is decoupled from the space requirement of the chain lifting element.



Maximum Performance

iwis push-pull chains are based on well-tested roller chains and are thus optimized for maximum performance and efficiency. With a compact push-pull chain drive, users can move large loads with minimal effort. Thanks to the clever redirection of the chain, the combination of load-free feeding and a thrust phase with maximum load is achieved.



(nearly) Unlimited Range

Limited drive technology is a thing of the past. Move heavy loads individually over long distances with the **VARIACTO**[®] push-pull chain drive. While conventional linear drives are strictly limited in their range, the **VARIACTO**[®] push-pull chain drive overcomes distances of up to 15 meters, depending on the design.

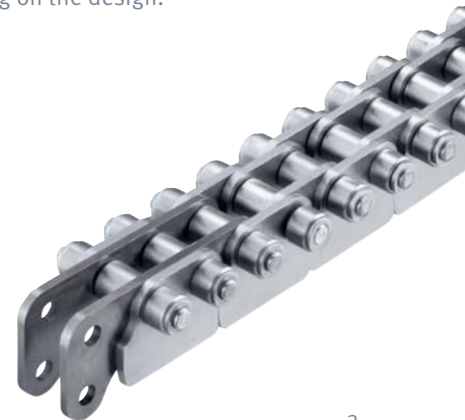



Product Extensions

VARIACTO® can be integrated into existing applications and easily adapted. A wide selection of initial lubricants ensures successful operation even in challenging environments. The modular chain station can be easily expanded to accommodate the required chain length. Various options for connecting the chain to the application ensure compatibility with your machine.



An Alternative to Conventional Drives

In comparison to conventional drives, **VARIACTO®** is a very clean and quiet solution. Since the drive does not include hydraulic or pneumatic lines, and hydraulic aggregates are not necessary, there is no risk of leakage. Noise from pumps and compressed air leakage is also eliminated.



Sustainable Drive Solution

The **VARIACTO®** push-pull chain drive is a mechanical system with high efficiency and suitability for direct electric drive. Problematic materials are not used in the production of the system. The high wear resistance and maintenance-friendly design of **VARIACTO®** ensure sustainable operation throughout its entire lifespan.

New Paths. Thinking Ahead.

Unable to reach your goal via a straight line? With **VARIACTO®**, we can bypass construction-related obstacles by redirecting the chain up to 180° as needed. Contact us regarding this type of custom solution.

Application Areas

Stage Technology (Lift Platform, Stage Platforms)

Pallet Trucks

Lift Platforms (Scissor Lifts)

Automatic Tool Change Applications



NEW GOALS: HIGHER AND FARTHER



About iwis

With our dedicated push-pull chain development and testing facility in Munich, Germany, iwis has continuously increased its expertise in the development of push-pull chain drives.

Linear Drive Technology: Rethinking Familiar Paths

Performance Data	VARIACTO L
Push-Pull Chain	M1611RSCUS
Chain Pitch	1" / 25.40 mm
Chain Tensile Strength (Pull)	90,000 N
Chain Tensile Strength (Push)	105,000 N (at 670 mm free length)
Max. Dynamic Load	10,000 N / Approx 1,000 kg
Max. Stroke Unguided	Standard 500 mm / Up to 700 mm
Max. Stroke Guided	15 meters
Min. Height	142 mm
Max. Speed	100 mm/s

Performance Data	VARIACTO L
Number of Sprocket Teeth	8
Dimensions (500 mm Stroke)	450 x 150 x 148 mm
Chain Weight	6.6 kg per meter (4.7 kg for 500 mm stroke)
Drive and Station Weight	13.6 kg
Max. Speed	28.8 rpm (at 100 mm/s stroke)
Max. Torque	331.9 Nm (at 10 kN load)
Compliance	RoHS, REACH
Declaration of Conformity	according to the Machinery Directive, EG2006/42/EG, Annex II B

Dimensions

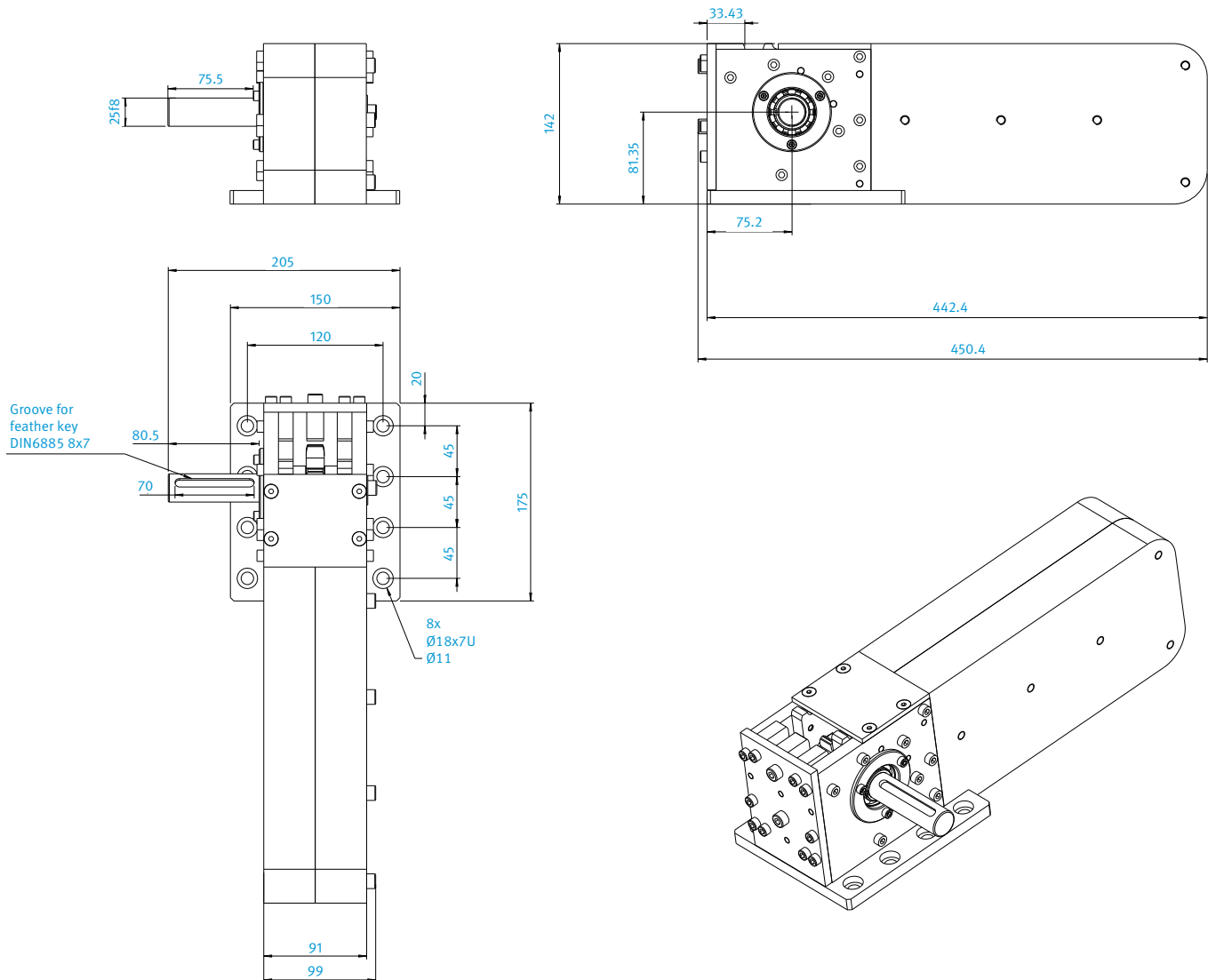

iwis

wir bewegen die welt



DISTRIBUTED BY



CHAIN & DRIVES
COMPLETE BEARINGS
& POWER TRANSMISSION

SERVICE & SUPPORT

Wangara, WA	Welshpool, WA	Arndell Park, NSW
+61 8 9303 4966	+61 8 6314 1155	+61 2 9674 8611
support@chainanddrives.com.au	salesnsw@chainanddrives.com.au	

chainanddrives.com.au