



Omega Elastomeric Couplings Catalog

Metric



DISTRIBUTED BY



CHAIN & DRIVES
COMPLETE BEARINGS
& POWER TRANSMISSION

SERVICE & SUPPORT

Wangara, WA
+61 8 9303 4966
support@chainanddrives.com.au

Welshpool, WA
+61 8 6314 1155
salesnsw@chainanddrives.com.au

Arndell Park, NSW
+61 2 9674 8611
salesnsw@chainanddrives.com.au

chainanddrives.com.au

Table of Contents

DESCRIPTION	PAGE
Omega® Elastomeric Couplings Overview	3
Selection Procedures	4
Typical Service Factors – Motor and Turbine Driven Equipment	5
CLOSE-COUPLED COUPLINGS	
Omega Close-Coupled Design with Straight Bore Hubs.	6
Omega Close-Coupled Design with Taper-Lock Bushed Hubs	7
SPACER COUPLINGS	
Omega Spacer Design with Straight Bore Hubs	8
Omega Spacer Design with Taper-Lock Bushed Hubs	9
Omega Extended Spacer Design.	10
ADDITIONAL COUPLINGS AND TECHNICAL DATA	
Special Designs	11
Adjustability	11
Ordering Instructions	12
Element and Hub Part Numbers	13
Bore Specifications	14

Rexnord Omega Elastomeric Couplings

Lowest Total Cost of Ownership

The unique split-in-half flex element and reversible hubs significantly decrease total costs by reducing inventory and assembly time.

Rexnord Omega Couplings are non-lubricated, material-flexing couplings utilizing a specially formulated polyurethane material engineered for maximum durability, strength and fatigue resistance. Omega couplings can operate in horizontal or vertical applications without additional components.

Easy installation and visual maintenance inspection make these couplings a perfect selection for a broad array of industrial applications.

Features and Benefits

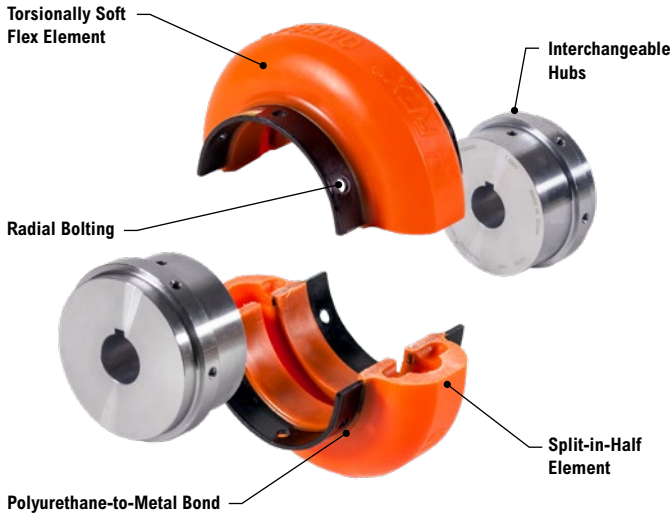

- **Torsionally Soft Flex Element** cushions shock loads and vibration, extending equipment life.
- **Split-in-Half Element** design allows for simplified assembly and disassembly without disturbing hubs or connected equipment.
- **Polyurethane-to-Metal Bond** eliminates assembly and slippage problems associated with mechanically clamped designs.
- **Interchangeable Hubs** between close coupled and spacer coupling elements. Hubs have identical bolting patterns which allows for reduced inventory, and are reversible to accommodate a variety of shaft spacing arrangements. Hubs are available in carbon steel, 303-304 stainless steel, or with electroless nickel plating.

Element Spacer Design Options

Omega Coupling elements are offered in Close Coupled (E), Spacer (ES), and Half Spacer (E/ES) designs to accommodate a variety of standard and non-standard Distance Between Shaft Ends (DBSE). Spacer elements offer multiple radial bolting holes to allow for different shaft spacing arrangements while limiting the quantity of parts required. Extended spacer adapters are supplied when shaft spacing requirements require a greater DBSE than the standard spacer element can provide.

Element Options

Standard Orange



- General purpose applications requiring the highest misalignment capacity

Heavy Duty Yellow (HDY)



- 25% greater torque capacity over Standard Orange catalog ratings allows for possible coupling downsizing
- Interchangeable with existing hubs

Hydrolytically Stable Urethane (HSU)



- Ideal for hot and humid conditions, acidic or alkaline environments
- Anti-corrosive element shoe coating available with HSU-J for improved corrosion resistance in highly caustic or acidic environments
- 12-16 year shelf life
- Interchangeable with existing hubs

Misalignment Capacity

Omega Standard Orange and HSU elements maintain their service life for any combination of parallel and angular misalignment measurements which fall on or below the line of the respective size. For Omega HDY, permissible misalignment values are shown in the yellow region and below the corresponding coupling size dotted line.

Coupling alignment is directly related to smooth, efficient equipment operation.

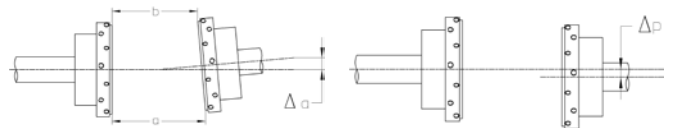
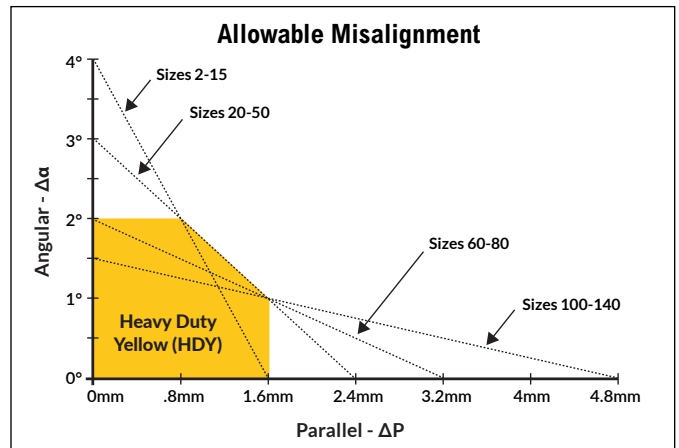

Angular Misalignment

Parallel Misalignment

Rexnord is the leading coupling provider in the industry with a full-line of available solutions supported by trained customer service and application engineering professionals focused on our coupling product lines. For more information, visit rexnord.com, or contact (866)-REXNORD.

Selection Procedures

1. **Determine Operating Torque:** $\left(\text{Torque (Nm)} = \frac{\text{KW} \times 9550}{\text{RPM}} \right)$

2. **Multiply by Service Factor:**

Select the proper Service Factor from Table on **page 5**.

3. **Select the Coupling Size:**

Select coupling size from **Table 2** with a capacity equal to or greater than determined in Step 2.

4. **Follow steps 5 & 6 below.**

OR

1. **Determine KW/100 RPM:** $\left(\text{kW/100 rpm} = \frac{\text{Kilowatt} \times 100/\text{RPM}}{\text{RPM}} \right)$

2. **Determine Service Factor:**

Select the proper Service Factor from Table on **page 5**. If not listed, see Load Classification Table on **page 5**. Remember to consider both driver and driven equipment and temperature requirements.

3. **Multiply KW/100 by the service factor to get equivalent KW/100 RPM.**

4. **Select the Coupling Size:**

From **Table 1**, with a rating equal to or greater than the equivalent KW/100 RPM determined in Step 3.

5. **Check Limiting Conditions:**

Be sure that the operating speed of the coupling does not exceed maximum RPM listed on **pages 8-11**.

6. **Select Desired Hub Type:**

Select desired hub type and check maximum allowable coupling bore.

Table 1

Size		Equivalent KW/100 RPM
Standard	Spacer	
E2M	ES2M	0,23
E3M	ES3M	0,43
E4M	ES4M	0,65
E5M	ES5M	1,10
E10M	ES10M	1,72
E15M	ES15M	2,13
E20M	ES20M	2,72
E30M	ES30M	4,31
E40M	ES40M	6,51
E50M	ES50M	9,05
E60M	ES60M	14,79
E70M	ES70M	26,07
E80M	ES80M	46,70
E100M	N/A	100,52
E120M	N/A	148,91
E140M	N/A	402,09





Table 2

Torque Capacity			
Size	Continuous Torque (Nm)	Size	Continuous Torque (Nm)
2	21,5	40	622
3	41,2	50	864
4	62,2	60	1 412
5	105	70	2 486
10	164	80	4 464
20	260	100	9 605
30	412	120	19 221
		140	38 443

Peak torque capacity of element is 250% of above continuous ratings.

Service Factors

Service Factors (S.F.) are a means of classifying different equipment and applications into various load classifications. Due to variations in application of equipment, service factors are used to adjust equipment ratings to accommodate for variable loading conditions. This is a general guide. More specific factors are given on **page 5**.

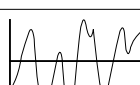
	Load Classifications	Service Factors
	Continuous service and running loads vary only slightly.	1,0
	Torque loading varies during operation of the equipment.	1,5
	Torque loading varies during operation, frequent stop/start cycles are encountered.	2,0
	For shock loading and substantial torque variations.	2,5
	For heavy shock loading or light reversing drives.	3,0
	Reversing torque loads do not necessarily mean reversal of rotation. Depending upon severity of torque reversal, such loads must be classified between "medium" and "extreme."	Consult Rexnord

Omega Element Temperature Range (Ambient) ①	
-40°F	-40°C
to	
+200°F	+93°C

High Temperature Service Factor Adjustment ①	
Ambient Temp.	S.F. Adjust.
66°C	0,25
74°C	0,50
82°C	0,75
93°C	1,00

① Added to application service factor.

The service factor adjustment for high temperature is in addition to the service factor consideration for the driver and driven equipment. However, if high temperatures are typical for a specific application, maximum temperature consideration is incorporated into the "typical" service factor listing on **page 5**, i.e., steel mill runout tables.

Typical Service Factors – Motor and Turbine Driven Equipment ^①

General Application	Typical Service Factor	Industry Application	Typical Service Factor	Industry Application	Typical Service Factor
AGITATORS		AGGREGATE PROCESSING, CEMENT		PULP & PAPER MILLS	
Vertical and Horizontal Screw Propeller, Paddle.....	1,5	Concrete Mixers.....	2,0	Agitator.....	1,5
BLOWERS		Crushers, Ore or Stone.....	3,0	Barking Drum.....	3,0
Centrifugal.....	1,0	Dryer, Rotary.....	2,0	Beater and Pulper.....	2,0
Lobe or Vane.....	1,5	Grizzly.....	3,0	Bleacher.....	1,0
CAR DUMPER AND PULLER	2,0	Hammermill.....	2,5	Calendar.....	2,5
COMPRESSORS		Mining Kilns.....	2,5	Chipper.....	3,5
Centrifugal.....	1,0	Tube, Rod and Ball Mills.....	2,5	Couch, Cylinder Dryer.....	2,0
Lobe or Vane.....	1,5	Tumbling Mill or Barrel.....	2,0	Felt Stretcher.....	1,0
Screw.....	1,25	BREWERY AND DISTILLING		Fourdrinier.....	2,0
Reciprocating.....	①	Bottling and Can Filling Machinery, Brew Kettle, Cooker, Mash Tub.....	1,0	Jordan.....	2,5
CONVEYORS		Scale Hopper (frequent peaks).....	2,0	Press.....	2,5
Apron, Assembly, Belt, Chain, Flight, Oven.....	1,5	FOOD INDUSTRY		Pulp Grinder.....	2,5
Reciprocating.....	②	Bottle and Can Filling.....	1,0	Stock Chests.....	1,5
Screw.....	1,25	Cereal Cooker.....	1,0	Stock Pump	
CRANES AND HOISTS		Dough Mixer, Meat Grinder.....	2,0	Centrifugal.....	1,25
Main Hoist – Medium Duty.....	2,0	LUMBER INDUSTRY		Reciprocating.....	2,5
Main Hoist – Heavy Duty.....	2,5	Band Resaw, Circular Resaw.....	2,0	Suction Roll.....	2,5
Skip Hoist.....	2,0	Edger, Head Rig, Hog, Log Haul.....	2,5	Winder.....	2,0
Bridge, Travel or Trolley.....	2,0	Planer.....	2,0	RUBBER INDUSTRY	
DREDGES		Rolls, Non-Reversing.....	2,0	Banbury Mixer.....	3,0
Cable Reel, Conveyor.....	2,0	Rolls, Reversing.....	2,5	Calendar.....	2,5
Cutter Head Drive, Jig Drive.....	3,0	Sawdust Conveyor.....	1,5	Cracker, Mix Mill, Plasticator, Refiner, Sheeter, Tire Building Machine.....	2,0
Pump, Screen, Drive, Stacker, Utility Winch.....	2,0	Slab Conveyor, Sorting Table.....	2,0	Tire and Tube Press Opener.....	1,0
DYNAMOMETER	1,0	OIL INDUSTRY		Tiber and Strainer.....	2,0
ELEVATORS		Chiller.....	1,0	Warming Mill.....	2,5
Bucket, Freight.....	2,5	POWER INDUSTRY		Washer.....	3,0
EXCITER, GENERATOR	1,0	Ash Handling Conveyors.....	1,5	STEEL INDUSTRY	
EXTRUDER, PLASTIC	2,0	Baghouse Air Handling Fans.....	1,5	Coilers.....	2,0
FANS		Ball Mill.....	2,5	Draw Benches.....	2,0
Centrifugal.....	1,0	Belt Conveyors.....	1,5	Edger Drives.....	2,0
Cooling Tower.....	2,0	Circulating pumps (centrifugal).....	1,0	Reel Drives.....	2,0
Forced Draft and Induced Draft.....	1,5	Coal Grinders and Crushers.....	2,5	Runout Tables (Non-Reversing).....	3,0
Large Mine.....	2,0	Coal Pulverizers and Hammermills.....	2,5	Runout Tables (Reversing).....	4,5
Propeller.....	1,5	Cooling Tower Fans.....	2,0	Soaking Pit Cover Drives.....	3,0
GENERATORS		FGD Slurry Pumps (centrifugal).....	1,0	Tube Conveyor Rolls.....	2,5
Even Load.....	1,0	Forced Draft Fan and Induced Draft Fan.....	1,5	Wire Drawing.....	2,0
Hoist or Railway Service.....	2,0	Primary Air, Recycling Fans.....	1,5	TEXTILE MILLS	
Welder Load.....	2,5	Traveling Water Screens.....	1,0	Batcher, Calendar, Card Machine, Dry Can.....	2,0
PRINTING PRESS	2,0			Dyeing Machinery.....	1,0
PUMPS				Loom.....	2,0
Centrifugal.....	1,0			Mangle, Napper, Soaper.....	1,5
Positive Displacement.....	1,5			Spinner, Tenter Frame.....	2,0
Gear, Lobe, Vane.....	1,5				
Reciprocating.....	②				
Progressive Cavity.....	1,25				
Peristaltic.....	1,5				
Screw.....	1,25				
SCREENS					
Air Washing.....	3,0				
Grizzly.....	1,0				
Coal and Sand (Rotary).....	2,0				
Vibrating.....	5,0				
SEWAGE DISPOSAL EQUIPMENT	1,5				
STOKER	1,5				

① The Service Factors listed are intended only as a general guide and for smooth power sources such as electric motors. For reciprocating prime movers, such as diesel or gas engines, add the following service factor:

For 8 or more cylinders, add 0,5

For 6 cylinders, add 1,0

For 4 cylinders, add 1,5

For less than 4 cylinders, consult Rexnord

Add 0,5 to service factor if drive is a hydraulic motor.

Omega Couplings are not recommended for turbine drives if the coupling cannot be protected from steam leakage or from speeds in excess of the coupling's published speed rating (pages 6-10).

② Consult Rexnord Engineering.

IMPORTANT NOTE: The coupling selection criteria is intended for the determination of the coupling and style only. It is also recommended that the system be analyzed for torsional and lateral stability using the specific coupling mass-elastic data available from Rexnord. This analysis is the responsibility of the user since the coupling is only a single component in the system.

SLEEVE BEARINGS: Drive systems sensitive to axial movement such as sleeve bearing motors require the use of a limited end float kit to maintain axial positioning. Consult Rexnord for design requirements and recommended installation practices.

CAUTION: Omega Couplings are not recommended for applications where both the driver and driven equipment are of reciprocating type. Contact Rexnord Application Engineering for review of Omega Coupling selection for reciprocating applications.

Omega Close-Coupled Design with Straight Bore Hubs

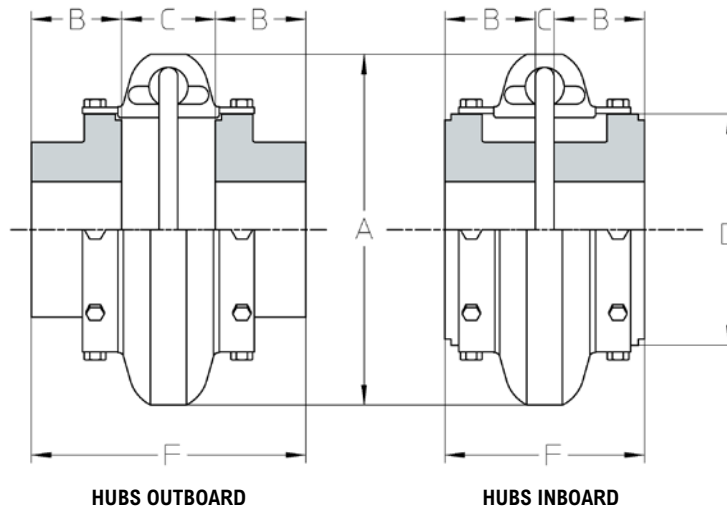

NOTE: Hub shoulder design varies per coupling size. Consult Rexnord for specific size assembly drawings.

Coupling Size	Minimum Bore (mm) ①	Recom. Max. Bore (mm)	Continuous Torque Rating (Nm)		Peak Torque Rating ③ (Nm)		Orange & HSU Element KW/100 RPM	Maximum RPM	Dimensions (mm)						Weight (kg) ⑤	
			Orange & HSU Element	HDY Element ②	Orange & HSU Element	HDY Element			A	B	C		D	F		
											(In) ④	(Out)		(In)		(Out)
E2M	13	28	22	28	55	69	0,23	6 600	89	24	36	48	47	82	96	0,54
E3M	13	34	41	51	103	128	0,43	6 600	102	38	8	34	59	97	109	1,09
E4M	13	42	62	78	155	194	0,65	6 600	116	38	8	34	66	97	119	1,36
E5M	13	48	105	131	263	328	1,10	6 600	137	44	8	47	80	109	135	2,45
E10M	13	55	164	205	410	513	1,72	6 600	162	44	8	47	93	109	141	3,72
E15M	13	55	203	254	508	634	2,13	6 600	162	44	8	47	93	109	141	3,76
E20M	21	60	260	325	650	813	2,72	6 600	184	50	13	60	114	117	165	5,90
E30M	21	75	412	515	1 030	1 288	4,31	5 800	210	58	12	61	138	132	179	9,53
E40M	26	85	622	778	1 555	1 945	6,51	5 000	241	63	8	68	168	141	195	15,9
E50M	26	90	864	1 080	2 160	2 700	9,05	4 200	279	70	11	86	207	156	226	24,5
E60M	31	105	1 412	1 765	3 530	4 410	14,79	3 800	318	82	8	87	222	183	252	32,7
E70M	31	120	2 486	3 108	6 215	7 770	26,03	3 500	356	85	18	96	235	203	279	39,0
E80M	31	155	4 460	5 575	11 150	13 938	46,70	2 000	406	114	17	127	286	267	375	77,1
E100M	48	171	9 600	12 000	24 000	30 000	100,52	1 900	533	140	44	95	359	324	375	111
E120M	48	190	19 220	24 025	48 050	60 000	201,26	1 800	635	152	57	124	448	362	429	193
E140M	48	229	38 440	48 050	96 100	120 125	402,51	1 500	762	178	76	127	530	432	483	338

- ① Minimum bore allows for smallest finished bore in a standard rough stock bore hub.
- ② HDY element continuous torque rating is 25% greater than orange and HSU elements.
- ③ Momentary Peak Torque overload is 250% of the allowable Continuous Torque Rating.
- ④ Minimum distance between shaft ends is 6mm.
- ⑤ With max bore hubs.

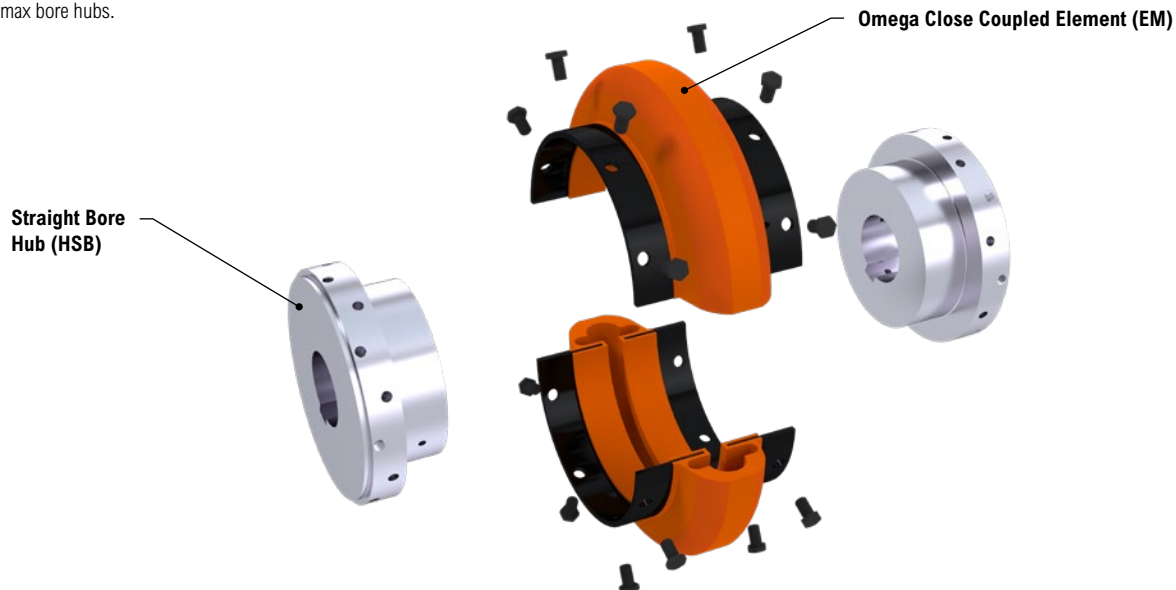

Omega Close-Coupled Design with Taper-Lock Bushed Hubs

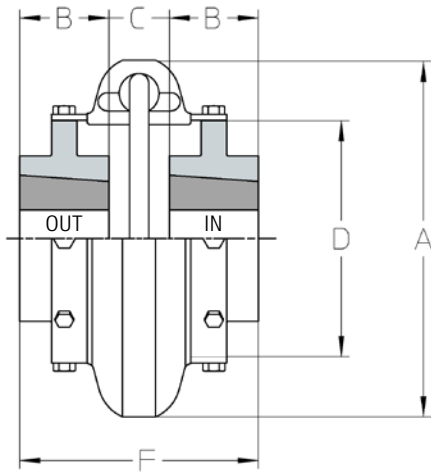

Sizes E3M - E80M (Symmetric Hub)

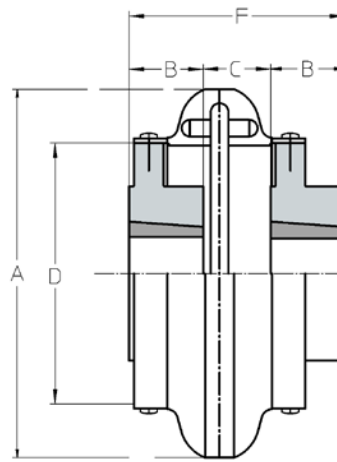

Sizes E100M - E140M (Asymmetric Hub)

Coupling Size	TL Bushing Number	Recom. Min. Bore (mm)	Recom. Max. Bore (mm) ①	Continuous Torque Rating (Nm)		Peak Torque Rating ③ (Nm)		Orange & HSU Element KW/100 RPM	Maximum RPM	Dimensions (mm)					Weight (kg) ④		
				Orange & HSU Element	HDY Element	Orange & HSU Element	HDY Element			A	B	C	D	F			
E3M	1008	13	25	41	51	103	128	0,43	6 600	102	22	43	59	87	0,82		
E4M	1008	13	25	62	78	155	194	0,65	6 600	116	22	43	66	87	1,18		
E5M	1210	13	32	105	131	261	328	1,10	6 600	137	25	52	80	102	1,81		
E10M	1610	13	42	164	205	410	513	1,72	6 600	162	25	52	93	102	2,72		
E15M	1610	13	42	203	254	509	634	2,13	6 600	162	25	52	93	102	2,77		
E20M	1610	13	42	260	325	650	813	2,72	6 600	184	25	64	114	114	4,08		
E30M	2012	13	50	412	515	1 030	1 288	4,31	5 800	210	32	65	138	129	6,17		
E40M	2517	13	65	622	778	1 555	1 945	6,51	5 000	241	45	60	168	150	9,89		
E50M	2517	13	65	864	1 080	2 160	2 700	9,05	4 200	279	45	76	207	166	14,3		
E60M	3020	24	80	1 412	1 765	3 530	4 410	14,79	3 800	318	51	84	222	186	21,1		
E70M	3535	31	95	2 486	3 108	6 215	7 770	26,03	3 500	356	89	60	235	238	30,3		
E80M	4040	37	105	4 460	5 575	11 150	13 938	46,70	2 000	406	102	95	286	299	37,2		
										(In) ⑤		(Out)		(In) ⑤		(Out)	
E100M	4545	50	115	9 600	12 000	24 000	30 000	100,52	1 900	533	114	38	152	359	267	381	113
E120M	5050	61	127	14 221 ②	14 221 ②	14 221 ②	14 221 ②	148,91 ②	1 800	635	127	51	181	448	305	435	185
E140M	7060	100	180	38 400	48 050	96 100	120 125	402,51	1 500	762	152	76	178	530	381	483	299

- ① With standard metric keyway. Consult bushing manufacturer for keyless bore options.
- ② Maximum bushing rating.
- ③ Momentary Peak Torque overload is 250% of the allowable Continuous Torque Rating.
- ④ Without Taper-Lock bushings.
- ⑤ Allow extra space between coupling ends and equipment for bushing assembly/disassembly. Reverse taper lock hubs are available for some sizes; consult Rexnord.

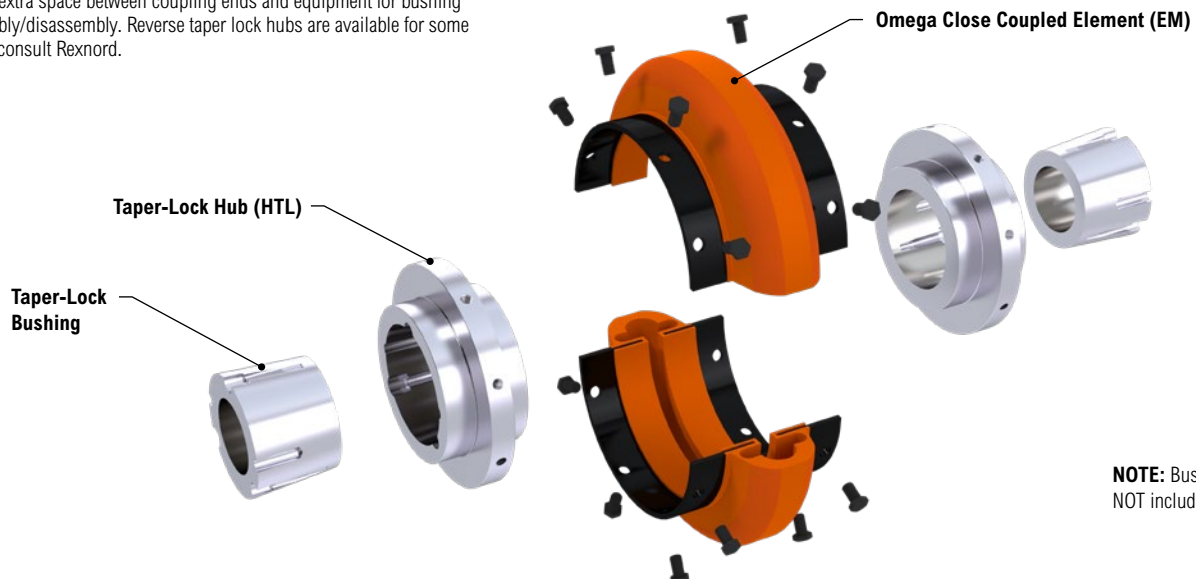

NOTE: Bushings are NOT included with hubs

Omega Spacer Design with Straight Bore Hubs

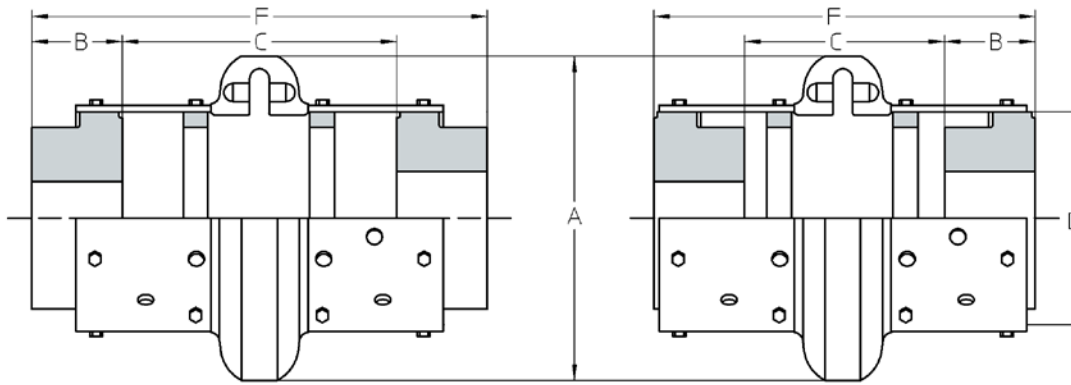

HUBS MOUNTED OUTBOARD

HUBS MOUNTED INBOARD

Coupling Size ①	Minimum Bore (mm) ②	Recom. Max. Bore (mm)	Continuous Torque Rating (Nm)		Peak Torque Rating ③ (Nm)		Orange & HSU Element KW/100 RPM	Max. RPM ④	Dimensions (in)						Weight (kg) ⑥	
			Orange & HSU Element	HDY Element	Orange & HSU Element	HDY Element			A	B	C		D	F		
											(In) ⑤	(Out)		(In)		(Out)
ES2-RM	13	28	22	28	55	69	0,23	6 600	89	24	91	100	47	146	150	1,04
ES3-RM	13	34	41	51	103	128	0,43	6 600	102	38	85	140	59	184	216	1,81
ES4-RM	13	42	62	78	155	194	0,65	6 600	116	38	85	140	66	184	216	2,31
ES5-RM	13	48	105	131	263	328	1,10	6 600	137	44	89	140	80	184	228	3,40
ES10-RM	13	55	164	205	410	513	1,72	6 600	162	44	89	140	93	184	228	4,67
ES15-RM	13	55	203	254	508	634	2,13	6 600	162	44	89	140	93	184	228	4,72
ES20M	21	60	260	325	650	813	2,72	4 800	184	50	67	180	114	238	280	7,08
ES30M	21	75	412	515	1 030	1 288	4,31	4 200	210	58	54	180	138	238	293	11,4
ES40M	26	85	622	778	1 555	1 945	6,51	3 500	241	63	41	180	168	238	307	18,1
ES50M	26	90	864	1 080	2 160	2 700	9,05	3 100	279	70	28	180	207	238	319	27,2
ES60M	31	105	1 412	1 765	3 530	4 410	14,79	2 800	318	82	66	250	222	318	415	38,1
ES70M	31	120	2 486	3 108	6 215	7 770	26,03	2 600	356	85	59	250	235	318	421	46,3
ES80M	31	229	4 460	5 575	11 150	13 938	46,70	1 800	406	114	37	250	286	318	478	81,6

① Suffix "R" designates high speed ring design. Rings are furnished standard for sizes ES2-RM to ES15-RM, optional for sizes ES20M to ES80M.

② Minimum bore allows for smallest finished bore in a standard rough stock bore hub.

③ Momentary Peak Torque overload is 250% of the allowable Continuous Torque Rating.

④ Spacer couplings furnished with optional high speed rings (sizes ES20M to ES80M) can be operated up to the maximum allowable speed of the standard close-coupled design of same size. See RPM Ratings on page 6.

⑤ Minimum shaft spacing is 6mm. See page 11 for additional details on allowable shaft engagement.

⑥ With max bore hubs.

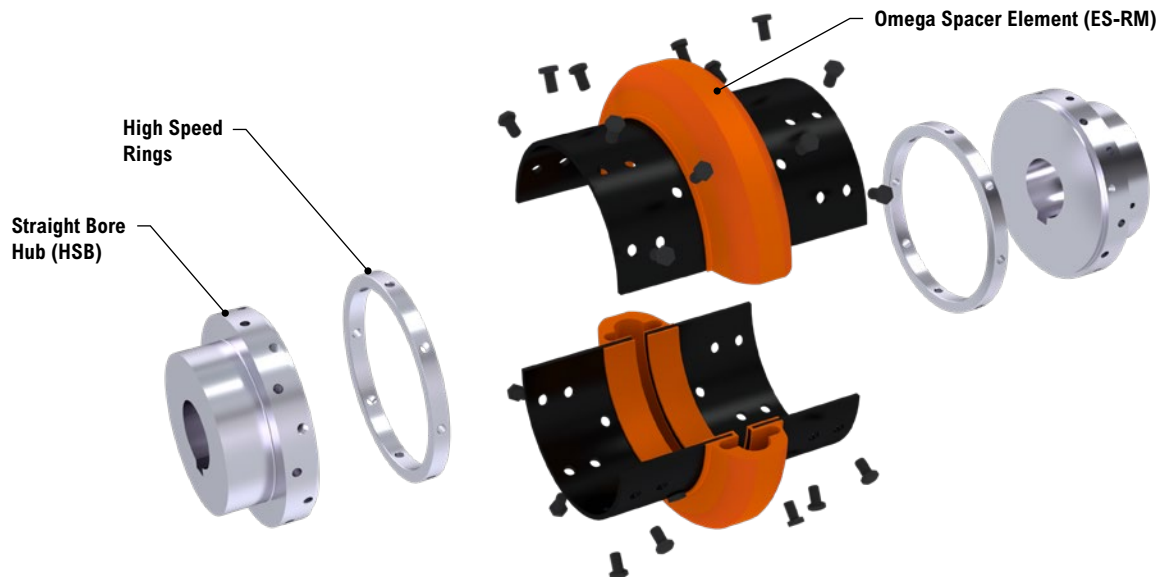

Omega Spacer Design with Taper-Lock Bushed Hubs

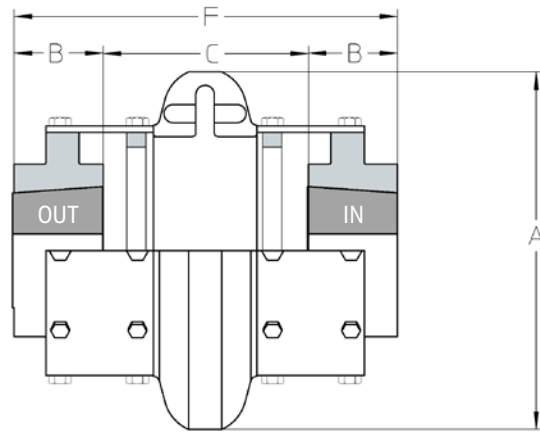

NOTE: Bushings are NOT included with hubs

Coupling Size ①	TL Bushing Number	Minimum Bore (mm)	Recom. Max. Bore (mm)	Continuous Torque Rating (Nm)		Peak Torque Rating ② (Nm)		Orange & HSU Element KW/100 RPM	Maximum RPM ③	Dimensions (mm)						Weight (kg) ⑤	
				Orange & HSU Element	HDY Element	Orange & HSU Element	HDY Element			A	B	C		D	F		
												(In) ④	(Out)		(In)		(Out)
ES3-RM	1008	13	25	41	51	103	128	0,43	6 600	102	22	97	137	59	184	184	1,45
ES4-RM	1008	13	25	62	78	155	194	0,65	6 600	116	22	97	137	66	184	184	1,91
ES5-RM	1210	13	32	105	131	263	328	1,10	6 600	137	25	97	133	80	184	184	2,72
ES10-RM	1610	13	42	164	205	410	513	1,72	6 600	162	25	94	133	93	184	184	3,58
ES15-RM	1610	13	42	203	254	508	634	2,13	6 600	162	25	94	133	93	184	184	3,63
ES20M	1610	13	42	260	325	650	813	2,72	4 800	184	25	123	172	114	238	238	5,40
ES30M	2012	13	50	412	515	1 030	1 288	4,31	4 200	210	32	117	165	138	238	238	8,16
ES40M	2517	13	65	622	778	1 555	1 945	6,51	3 500	241	45	104	153	168	238	244	12,2
ES50M	2517	13	65	864	1 080	2 160	2 700	9,05	3 100	279	45	104	153	207	238	244	17,0
ES60M	3020	24	80	1 412	1 765	3 530	4 410	14,79	2 800	318	51	155	223	222	318	326	27,5
ES70M	3535	31	95	2 486	3 108	6 215	7 770	26,03	2 600	356	89	117	185	235	318	364	36,9
ES80M	4040	37	105	4 460	5 575	11 150	13 938	46,70	1 800	406	102	104	172	286	318	377	42,3

- ① Suffix "R" designates high speed ring design. Rings are furnished standard for sizes ES2-RM to ES15-RM, optional for sizes ES20M to ES80M.
- ② Momentary Peak overload is 250% of the allowable Continuous Torque Rating.
- ③ Spacer couplings furnished with optional high speed rings (sizes ES20M to ES80M) can be operated up to the maximum allowable speed of the standard close-coupled design of similar size. See RPM Ratings on **page 6**.
- ④ Minimum shaft spacing is 6mm. See **page 11** for additional details on allowable shaft engagement.
- ⑤ Without Taper-Lock bushings.

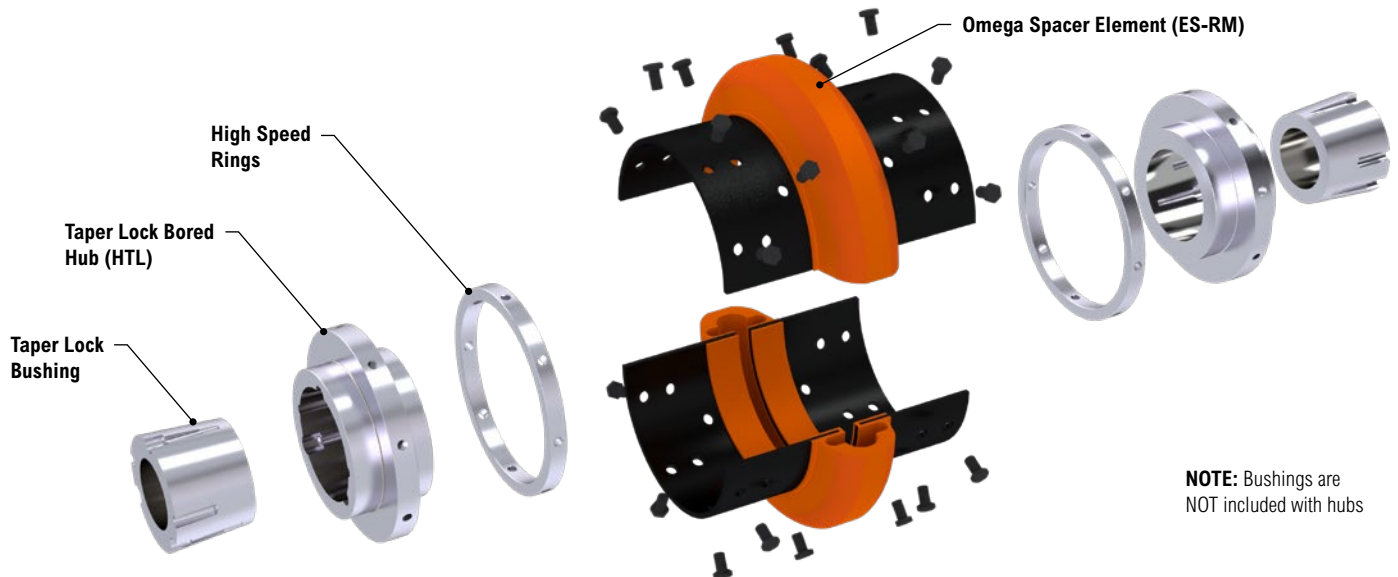

NOTE: Bushings are NOT included with hubs

Omega Extended Spacer Coupling

Rexnord Omega Extended Spacer Couplings are designed to connect equipment with shaft spacing requirements beyond the Omega Spacer Coupling capabilities. The extended spacer design can be an economic alternative to floating shaft couplings (i.e. stock pump applications).

Sleeve extensions (“SE”) are furnished in steel. They mount to regular Omega Spacer Elements and all Omega Coupling Hubs.

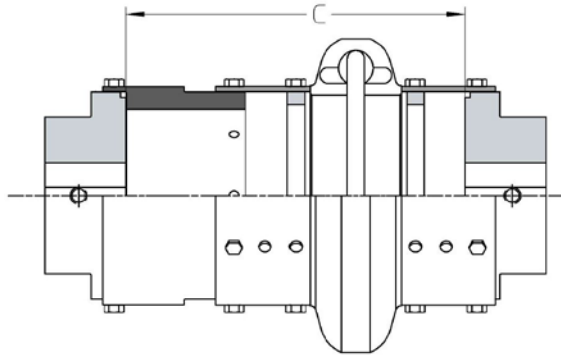

SINGLE EXTENSION

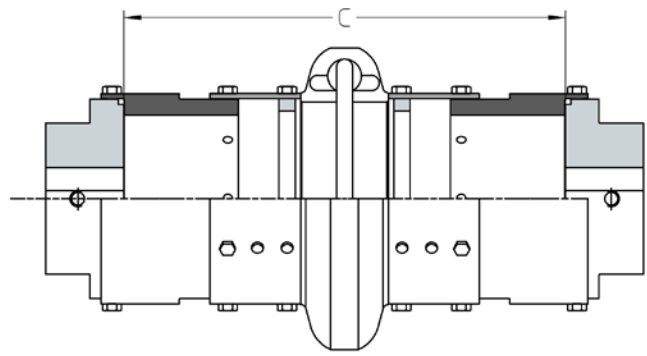

DOUBLE EXTENSION

Spacer Size	Max. RPM Standard	Max. RPM Matched Assembly ②	Maximum Spacing - “C” Dimension (mm) ①						Weight Of One SE (kg)
			With Straight Bore Hubs			With Taper-Lock Hubs			
			Max. Without SE	One SE	Two SE	Max. Without SE	One SE	Two SE	
ES3-RM	1 800	3 600	140	190	240	137	187	237	0,54
ES4-RM	1 800	3 600	140	190	240	137	187	237	0,64
ES5-RM	1 800	3 600	140	190	240	133	183	233	0,68
ES10-RM	1 800	3 600	140	190	240	133	183	233	0,73
ES15-RM	1 800	3 600	140	190	240	133	183	233	0,73
ES20M	1 800	3 600	180	250	320	172	242	312	1,68
ES30M	1 800	3 600	180	250	320	165	235	305	2,05
ES40M	1 800	3 500	180	250	320	153	223	293	2,40
ES50M	1 800	3 100	180	250	320	153	223	293	3,63
ES60M	1 800	2 800	250	367	484	223	340	457	9,43
ES70M	1 800	2 600	250	386	522	185	321	457	15,69
ES80M	1 500	1 800	250	393	536	172	315	458	20,96
E100M	1 500	1 800	95	228	361	152	285	418	34,47
E120M	1 500	1 800	124	251	378	181	308	435	36,88
E140M	1 200	1 500	127	267	407	178	318	458	55,34

① Maximum spacings shown are with hubs outboard and flush with shaft ends.

② Hub/sleeve extension assembly is precisely machined and matched to obtain higher speed rating. Specify “Matched Assembly” at time of quote.

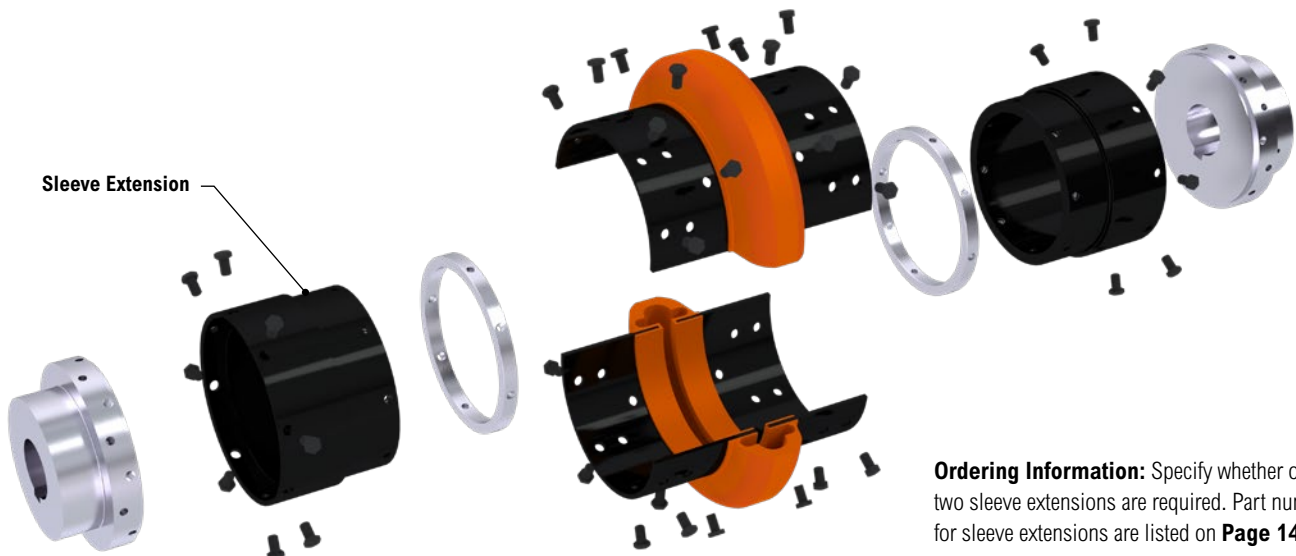

Ordering Information: Specify whether one or two sleeve extensions are required. Part numbers for sleeve extensions are listed on **Page 14**.

Special Designs

Omega E/ES Half Spacer Element

Option for a shorter element length than a standard ES spacer coupling.
Available in Standard Orange, HDY Yellow, or HSU Green materials.

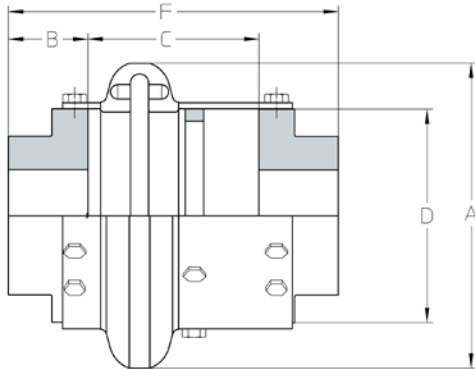

Coupling Size	Dimensions (mm)				Weight (kg) ②
	C		F		
	(In) ①	(Out)	(In)	(Out)	
E2M	61	76	114	123	0,79
E3M	54	81	140	156	1,45
E4M	49	81	140	166	1,84
E5M	55	88	147	175	2,93
E10M	51	88	147	182	4,20
E15M	48	99	147	182	4,24
E20M	37	123	178	224	6,49
E30M	28	126	185	237	10,47
E40M	28	131	190	250	17,00
E50M	15	138	197	272	25,85
E60M	37	177	250	333	35,40
E70M	33	185	260	356	42,62
E80M	28	208	292	435	79,35

① Minimum distance between shaft ends is 6mm.

② With maximum bore hubs.

Rexnord Positive Drive Coupling

Interlocking hubs to meet fail-safe requirements.

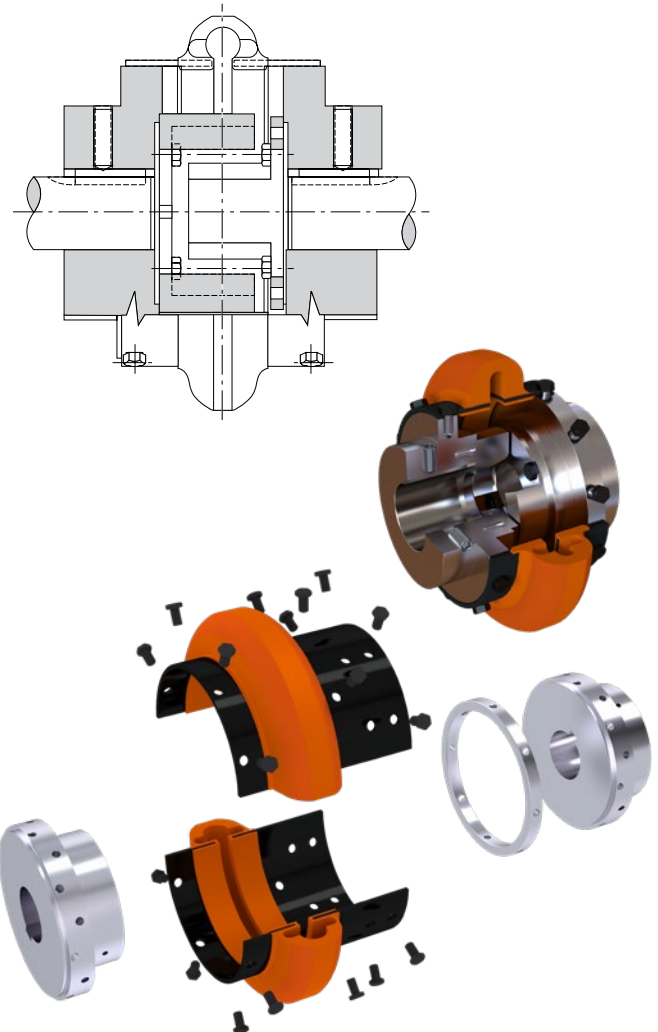

Electroless Nickel Plated Hubs

Omega Hubs can be supplied with electroless nickel plating, or machined in stainless steel material to provide advanced corrosion protection over standard carbon steel hubs for applications in harsh environments.

Adjustability

Shaft Spacing Options

The Rexnord Omega Spacer Coupling design (pages 8-9) provides additional spacing between hubs. There are no interfering center member components which allows shaft spacing as small as 6mm; however, for such small spacings, use of the standard Omega close coupled element would be recommended. The maximum shaft spacing for each coupling is shown on pages 8-9. Any ANSI, ISO, or DIN spacing between 6mm and the maximum listed can be achieved without additional parts. Hubs can be mounted on shafts as shown below.

Overhanging Hubs

Hubs can be mounted flush with the shaft end (Figure A), recessed behind the shaft end (Figure B) or overhang the shaft end (Figure C). Shaft engagement with the hub should be greater than or equal to 80% of the hub length through bore. Compression bushed hubs require 100% shaft engagement.

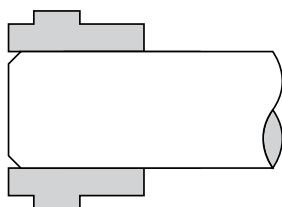

Figure A

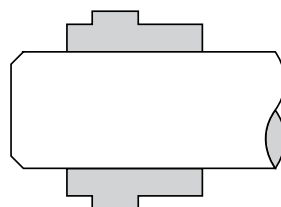

Figure B

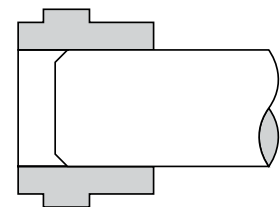

Figure C

Ordering Instructions

Standard and Spacer Couplings

When ordering a complete coupling, specify coupling size, type of element and hubs bores.

Element

[E2M – E140M] Close Coupled
[ES2-RM – ES80M] Spacer

Hub

[2MHRB – 140MHRB] Hub – Rough Bore
[2MHSB – 60MHSB] Hub – Stock Bore
[2MHCB – 140MHCB] Hub – Custom Bore (specify bore and keyway)
[3MHTL – 140MHTL] Hub – Taper-Lock® (bushing not included)

Order Example

Complete E50M close-coupled coupling with one finished bore 60mm HCB hub with standard keyway and one Taper-Lock hub less bushing.
Order description:

1 ea. E50M Element
1 ea. 50 HCB x 60mm Hub
1 ea. 50 MHTL

Spline Bores

When ordering a complete coupling, specify coupling size, type of element and hubs bores.

1. Number of Teeth – Ex. 14T
2. Pitch Fraction – Ex. 12/24 Pitch
3. Pressure Angle – 30° P.A.
4. Type of Tooth Shape – Ex. Involute or Straight Side
5. Type of Root – Ex. Fillet or Flat Root
6. Tolerance – Ex. Class I through VII
7. Type of Fit – Ex. Side Fit or Major Diameter Fit

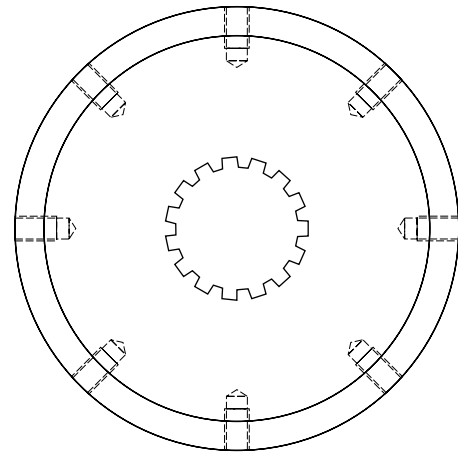

Tapered Bores

1. Drawing of HUB showing complete bore and keyway details.

— OR —

2. Drawing of SHAFT with dimensions shown below, allowing Rexnord to bore hubs to suit.

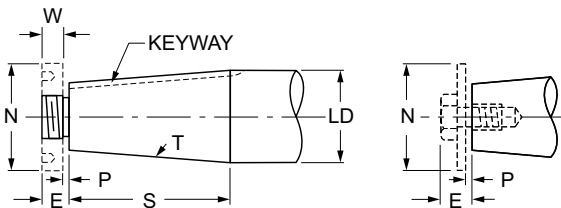

- (LD) Large diameter, specify in millimeters.
- (S) Length of taper, measure parallel to shaft centerline.
- (T) Taper per meter or millimeter (difference in diameter in one unit of length OR taper rate).
- (P) Clearance space for drawing hub up onto the tapered shaft. Usually 3mm-6mm depending on shaft size and taper.
- (N) Nut or keeper plate diameter

NOTE: Specify if keyway is parallel to taper or if parallel to shaft centerline. Specify keyway depth at larger diameter of taper if keyway is parallel to shaft centerline.

With connected equipment in fixed position, the following additional information is necessary:

Dimensions "V" and "X" must be given when one or both connected machines are fixed on their bases. Advise if dimension "X" is fixed, or if variable, between what limits.

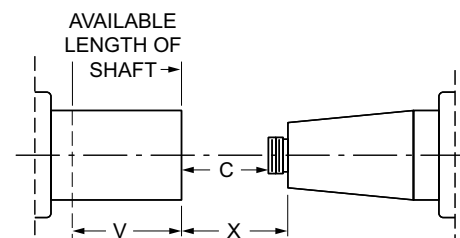

A fixed "X" dimension may require variable positioning on the shaft, allowing for the use of a standard straight bore hub. See illustrations below.

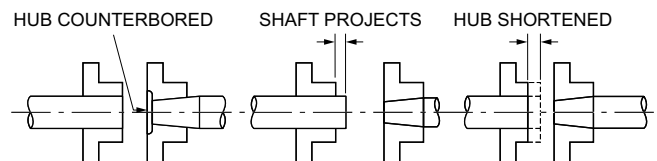

Element and Hub Part Numbers

Omega Metric Coupling Element Part Numbers

Size	Omega Coupling Elements					
	Close Coupled EM	Spacer ESM ^①	Close Coupled EM-HDY	Spacer ESM-HDY	Close Coupled EM-HSU	Spacer ESM-HSU
2M	10287702	10287813	10287703	10287814	10287704	10287815
3M	10287709	10287820	10287710	10287821	10287711	10287822
4M	10287716	10287827	10287717	10287828	10287718	10287829
5M	10287723	10287834	10287724	10287835	10287725	10287836
10M	10287730	10287841	10287731	10287842	10287732	10287843
15M	10287737	10287848	10287738	10287849	10287739	10287850
20M	10287744	10287855	10287745	10287856	10287746	10287857
30M	10287751	10287862	10287752	10287863	10287753	10287864
40M	10287758	10287869	10287759	10287870	10287760	10287871
50M	10287765	10287876	10287766	10287877	10287767	10287878
60M	10287772	10287883	10287773	10287884	10287774	10287885
70M	10313984	10287890	10287779	10287891	10287780	10287892
80M	10287785	10287897	10287786	10287898	10287787	10287899
100M	10287792	...	10287793	...	10287794	...
120M	10287799	...	10287800	...	10287801	...
140M	10287806	...	10287807	...	10287808	...

① High Speed Rings are furnished standard for sizes ES2-RM to ES15-RM, optional for sizes ES20M to ES80M.

Omega Metric Coupling Hub and Accessory Part Numbers

Size	Omega Hubs			Accessories			
	Rough Stock Bore		BSW Taper Lock Bushed Hub	Sleeve Extension	High Speed Rings ^①	Carbon Steel Capscrew Kit	Capscrew Quantity and Size
	Carbon Steel	Stainless Steel					
2M	10287901	10287903	10313589	10287505	Qty. 16 - M6-1.0 X 10
3M	10287904	10287906	10287950	10287976	10314450	10315706	Qty. 16 - M6-1.0 X 12
4M	10287907	10287909	10287951	10287978	10312742	10315706	Qty. 16 - M6-1.0 X 12
5M	10287910	10287912	10287952	10287980	10315336	10315706	Qty. 16 - M6-1.0 X 12
10M	10287913	10287916	10287953	10287982	10316537	10314444	Qty. 20 - M6-1.0 X 12
15M	10287919	10287921	10287954	10287974	10315400	10741705	Qty. 20 - M8-1.25 X 12
20M	10287922	10287924	10287955	10287984	10299687	10287672	Qty. 12 - M10-1.5 X 12
30M	10287925	10287918	10287956	10287986	10299688	10287672	Qty. 12 - M10-1.5 X 12
40M	10287926	10287928	10287957	10287988	10299689	10287674	Qty. 16 - M10-1.5 X 16
50M	10287929	10287931	10287958	10287990	10299690	10287674	Qty. 16 - M10-1.5 X 16
60M	10287932	10287934	10287959	10287992	10299691	10287676	Qty. 16 - M12-1.75 X 25
70M	10287935	10287937	10287960	10287994	10299692	10287676	Qty. 16 - M12-1.75 X 25
80M	10287938	10287940	10287961	10287996	10299693	10287676	Qty. 16 - M12-1.75 X 25
100M	10287941	10287943	10315708	10287998	...	10313747	Qty. 20 - M20-2.5 X 40
120M	10287944	10287946	10287963	10288000	...	10315204	Qty. 24 - M20-2.5 X 40
140M	10287947	10287949	10287964	10288002	...	10741766	Qty. 32 - M24-3 X 40

① High Speed Rings are furnished standard for sizes ES2-RM to ES15-RM, optional for sizes ES20M to ES80M.

Bore Specification

Recommended Bore Tolerances Steel Coupling Hubs - Millimeters

Shaft Diameter (ISO/R775-1969)		Bore Diameter Tolerance		
Nominal	Tolerance	Clearance	Transitional	Interference
6 to 30	j6 / k6 ①	F7	H7	M6
Over 30 to 50	k6	F7	H7	K6
Over 50 to 80	m6	F7	H7	K7
Over 80 to 100	m6	F7	H7	M7
Over 100 to 200	m6	F7	H7	P7
Over 200 to 355	m6	F7	H7	R7
Over 355 to 500	m6	F7	H7	R8

① Per DIN 748 - Differs from ISO/R775

Bore Tolerances

Omega metric bore hubs are supplied with an H7 transitional fit tolerance and single setscrew over the keyway as standard. Clearance, interference, or a custom bore tolerance can be supplied upon request.

Recommended Bores for Metric Shafts per ISO/R775 - 1969 (ANSI/AGMA 9112)

	Shaft Diameter	Clearance Fit		Transitional Fit		Interference Fit	
		Hub Bore	Fit	Hub Bore	Fit	Hub Bore	Fit
MM	j6 + 0,008 / - 0,003	F7 + 0,016 / + 0,034	+ 0,008 + 0,037	H7 + 0,000 / + 0,018	- 0,008 + 0,021	M6 - 0,015 / - 0,004	- 0,023 - 0,001
12	12,008/11,997	12,016/12,034	↓	12,000/12,018	↓	11,985/11,996	↓
14	14,008/13,997	14,016/14,034	↓	14,000/14,018	↓	13,985/13,996	↓
16	16,008/15,997	16,016/16,034	↓	16,000/16,018	↓	15,985/15,996	↓
18	18,008/17,997	18,016/18,034	↓	18,000/18,018	↓	17,985/17,996	↓
MM	j6 + 0,009 / - 0,004	F7 + 0,020 / + 0,041	+ 0,011 + 0,045	H7 + 0,000 / + 0,021	- 0,009 + 0,025	M6 - 0,017 / - 0,004	- 0,026 + 0,000
19	19,009/18,996	19,020/19,041	↓	19,020/19,041	↓	18,983/18,996	↓
20	20,009/19,996	20,020/20,041	↓	20,020/20,041	↓	20,983/20,996	↓
22	22,009/21,996	22,020/22,041	↓	22,020/22,041	↓	21,983/21,996	↓
24	24,009/23,996	24,020/24,041	↓	24,020/24,041	↓	23,983/23,996	↓
25	25,009/24,996	25,020/25,041	↓	25,020/25,041	↓	24,983/24,996	↓
28	28,009/27,996	28,020/28,041	↓	28,020/28,041	↓	27,983/27,996	↓
30	30,009/29,996	30,020/30,041	↓	30,020/30,041	↓	29,983/29,996	↓
>30	k6 + 0,018 / + 0,002	F7 + 0,025 / + 0,050	+ 0,007 + 0,048	H7 + 0,000 / + 0,025	- 0,018 + 0,023	K6 - 0,013 / + 0,003	- 0,031 + 0,001
32	32,018/32,002	32,025/32,050	↓	32,000/32,025	↓	31,987/32,003	↓
35	35,018/35,002	35,025/35,050	↓	35,000/35,025	↓	34,987/35,003	↓
38	38,018/38,002	38,025/38,050	↓	38,000/38,025	↓	37,987/38,003	↓
40	40,018/40,002	40,025/40,050	↓	40,000/40,025	↓	39,987/40,003	↓
42	42,018/42,002	42,025/42,050	↓	42,000/42,025	↓	41,987/42,003	↓
45	45,018/45,002	45,025/45,050	↓	45,000/45,025	↓	44,987/45,003	↓
48	48,018/48,002	48,025/48,050	↓	48,000/48,025	↓	47,987/48,003	↓
50	50,018/50,002	50,025/50,050	↓	50,000/50,025	↓	49,987/50,003	↓
>50	m6 + 0,030 / + 0,011	F7 + 0,030 / + 0,060	+ 0,000 + 0,049	H7 + 0,000 / + 0,030	- 0,030 + 0,019	K7 - 0,021 / + 0,009	- 0,051 - 0,002
55	55,030/55,011	55,030/55,060	↓	55,000/55,030	↓	54,975/55,009	↓
56	56,030/56,011	56,030/56,060	↓	56,000/56,030	↓	55,975/56,009	↓
60	60,030/60,011	60,030/60,060	↓	60,000/60,030	↓	59,975/60,009	↓
63	63,030/63,011	63,030/63,060	↓	63,000/63,030	↓	62,975/63,009	↓
65	65,030/65,011	65,030/65,060	↓	65,000/65,030	↓	64,975/65,009	↓
70	70,030/70,011	70,030/70,060	↓	70,000/70,030	↓	69,975/70,009	↓
71	71,030/71,011	71,030/71,060	↓	71,000/71,030	↓	70,975/71,009	↓
75	75,030/75,011	75,030/75,060	↓	75,000/75,030	↓	74,975/75,009	↓
80	80,030/80,011	80,030/80,060	↓	80,000/80,030	↓	79,975/80,009	↓
>80	m6 + 0,035 / + 0,013	F7 + 0,036 / + 0,071	+ 0,001 + 0,058	H7 + 0,000 / + 0,035	- 0,035 + 0,022	M7 - 0,035 / + 0,000	- 0,070 - 0,013
85	85,035/85,013	85,036/85,071	↓	85,000/85,035	↓	84,965/85,000	↓
90	90,035/90,013	90,036/90,071	↓	90,000/90,035	↓	89,965/90,000	↓
95	95,035/95,013	95,036/95,071	↓	95,000/95,035	↓	94,965/95,000	↓
100	100,035/100,013	100,036/100,071	↓	100,000/100,035	↓	99,965/100,000	↓
>100	m6 + 0,035 / + 0,013	F7 + 0,036 / + 0,071	+ 0,003 + 0,068	H7 + 0,000 / + 0,035	- 0,040 + 0,025	P7 - 0,059 / - 0,024	- 0,094 - 0,037
110	110,035/110,013	110,036/110,071	↓	110,000/110,035	↓	109,941/109,976	↓
120	120,035/120,013	120,036/120,071	↓	120,000/120,035	↓	119,941/119,976	↓
>120	m6 + 0,040 / + 0,015	F7 + 0,043 / + 0,083	+ 0,003 + 0,068	H7 + 0,000 / + 0,040	- 0,040 + 0,025	P7 - 0,068 / - 0,028	- 0,108 - 0,043
125	125,040/125,015	125,043/125,083	↓	125,000/125,040	↓	124,932/124,972	↓
130	130,040/130,015	130,043/130,083	↓	130,000/130,040	↓	129,932/129,972	↓
140	140,040/140,015	140,043/140,083	↓	140,000/140,040	↓	139,932/139,972	↓
150	150,040/150,015	150,043/150,083	↓	150,000/150,040	↓	149,932/149,972	↓
160	160,040/160,015	160,043/160,083	↓	160,000/160,040	↓	159,932/159,972	↓
170	170,040/170,015	170,043/170,083	↓	170,000/170,040	↓	169,932/169,972	↓
180	180,040/180,015	180,043/180,083	↓	180,000/180,040	↓	179,932/179,972	↓



OUR INNOVATION MOVES

DISTRIBUTED BY



SERVICE & SUPPORT

Wangara, WA	Welshpool, WA	Arndell Park, NSW
+61 8 9303 4966	+61 8 6314 1155	+61 2 9674 8611
support@chainanddrives.com.au	salesnsw@chainanddrives.com.au	
chainanddrives.com.au		

ALL AROUND THE GLOBE,



CUSTOMERS TRUST OUR PROVEN BRANDS.

WHY CHOOSE REXNORD?

When it comes to providing highly engineered products that improve productivity and efficiency for industrial applications worldwide, Rexnord is the most reliable in the industry. Commitment to customer satisfaction and superior value extend across every business function.

Delivering Lowest Total Cost of Ownership

The highest quality products are designed to help prevent equipment downtime and increase productivity and dependable operation.

Valuable Expertise

An extensive product offering is accompanied by global sales specialists, customer service and maintenance support teams, available anytime.

Solutions to Enhance Ease of Doing Business

Commitment to operational excellence ensures the right products at the right place at the right time.