

Mönninghoff

Pneumatic tooth brake

Type 679

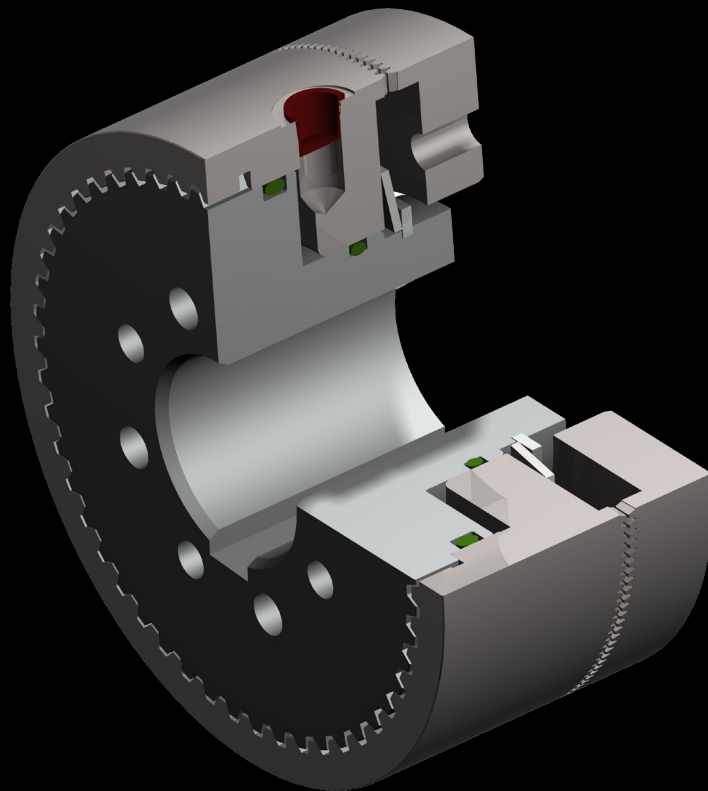

CHAIN & DRIVES[®]
COMPLETE BEARINGS
& POWER TRANSMISSION

POWER > SPEED > TORQUE

Pneumatic tooth brake - Type 679

Characteristics and features

- positive-locking transmission of torque without slip
- designs up to 1000 Nm possible
- no additional energy supply necessary
- oil running or dry running
- compressed-air is fed through the shifting ring
- not suitable for rotary use, because of the external compressed air connection
- engageable also at low relative speed
- high range of temperatures
- application-related customized tooth geometries
- synchronized switching with fixed engagement positions
- under certain circumstances available as torque limiter
- uncompromizing need for safety and reliability
- integrated, easy-to-assemble system solution
- condition monitoring on demand



Mönninghoff power transmission represents an infinite variant diversity that is applied by all areas of modern mechanical engineering.

Our technologies are mostly designed to operate under extreme conditions. We offer high precision products for medical robotics, fail-proof security for aerospace technology or synchronization solutions for the packaging or printing industry.

We thus address customers who have the highest standards for their own machines or systems. To them, we can offer highly complex, application-specific solutions.

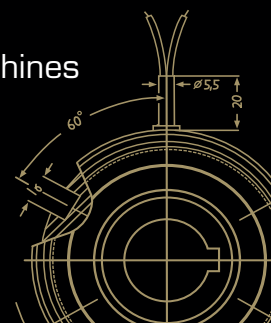

Pneumatic tooth brake - Type 679

Match code

Mönninghoff pneumatic tooth brakes are indicated by the following match code:

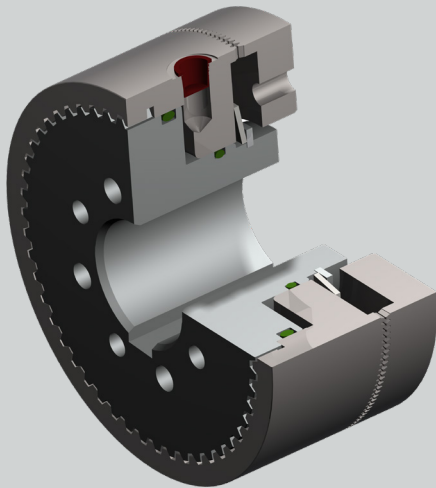

679 . A . 1 . B

- A** brake size
- B** indicator plate

Other individual characteristics:

- tothing geometries
- bore size with keyway

According to these characteristics, we design individual solutions concerning transmitted torque, engaging behavior or rotation speed.

Our engineers can assist with finding an application-specific brake at any time. Together, we can develop individual and innovative solutions for extreme operating conditions.

Ordering example

Mönninghoff pneumatic tooth brake
Type 679.15.1.4

Tothing	standard
Bore size d	30 mm H7 keyway acc. to DIN 6885/1

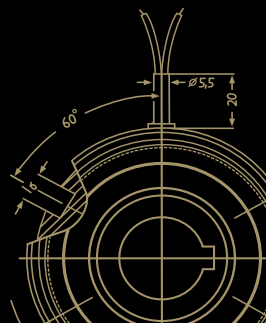

Pneumatic tooth brake - Type 679

Brake size

When dimensioning a Mönninghoff pneumatic tooth brake, several technical preconditions should be considered:

- for the selection of the correct size, not only the peak load but also the dynamic behavior of the drive have to be taken into account
- tooth brakes - contrary to friction brakes - must never be overloaded and safety factors must be considered
- generally, the selection of the correct brake is based on torque:

$$M = 9550 \frac{P}{n} \cdot K \text{ [Nm]}$$

$$M = (M_L + M_B) \cdot K \text{ [Nm]}$$

- the transmittable torque of the brake must always be higher than the largest possible occurring torque:

$$\text{Requirement } M_{\ddot{U}} > M$$

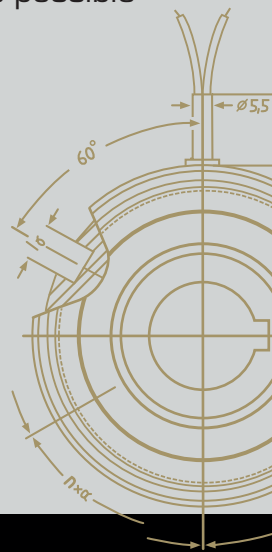

- P = power of motor [kW]
n = rotating speed [min^{-1}]
K = safety factor 1,5 ... 2,5
M = required torque
 M_L = load torque
 M_B = acceleration torque
 $M_{\ddot{U}}$ = nominal torque of brake (see enclosed chart)

Pneumatic tooth brake - Type 679

Brake size

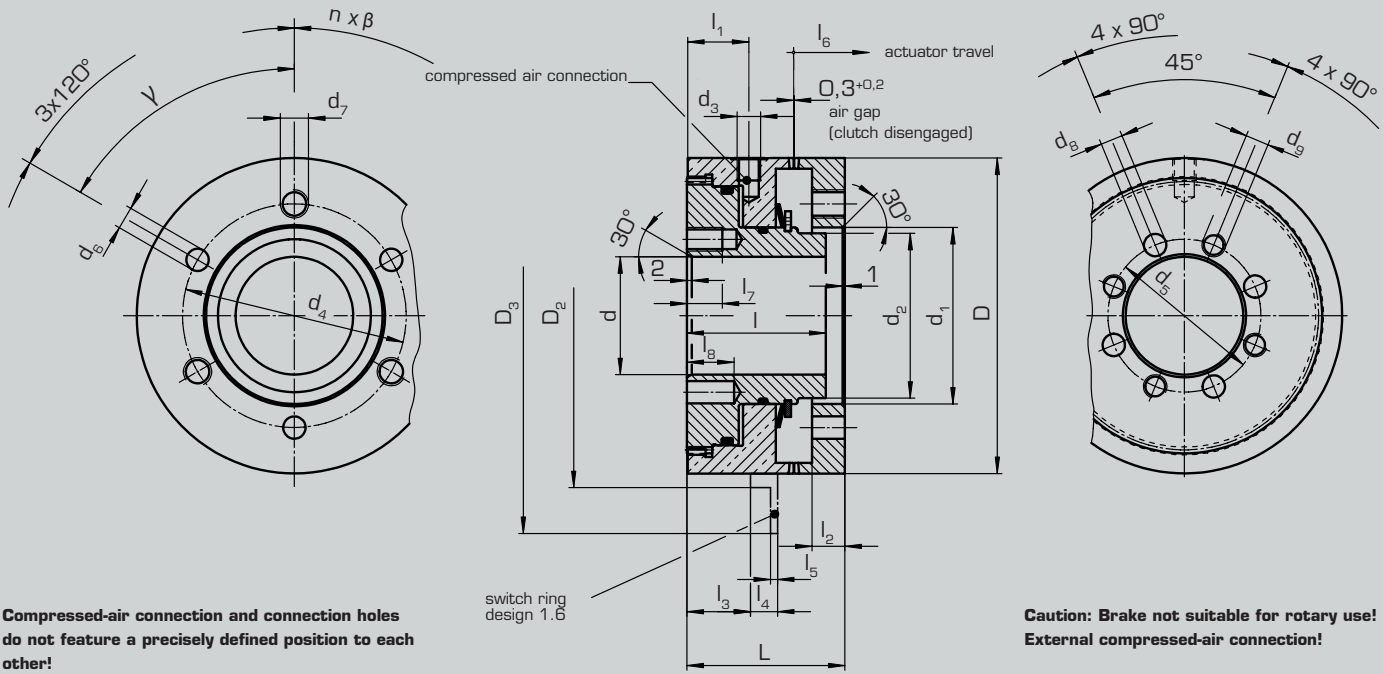

Compressed-air connection and connection holes do not feature a precisely defined position to each other!

Caution: Brake not suitable for rotary use!
External compressed-air connection!

Design 1.4

Technical data

Size		15	21	23	25	31
torque	[Nm]	80	180	300	500	1000
max. speed	[n/min ¹]	5000	4500	4000	4000	3000
operating pressure	min. p [bar]	5	6	4	5	5
axial force	engaged [N]	715	1225	1780	2540	3400
min. bore	keyway acc. to DIN 6885/1 d H7 [mm]	20	25	30	30	45
max. bore		30	35	40	50	65
dimensions	D [mm]	82	95	114	134	166
	D_2	90	107	126	146	178
	D_3	115	130	165	185	218
	d_1 H7	46	55	60	75	95
	d_2	42	50	55	70	90
	d_3	M5	M5	G 1/8	G 1/8	G 1/8
	d_4	60	72	80	95	120
	d_5	39	44	53	65	85
for locating pin	d_6/d_8	5,5/4,5	7,5/5,5	7,5/7,5	9,5/9,5	9,5/9,5
thread	d_7/d_9	M6/M5	M8/M6	M8/M8	M12/M10	M12/M10
	$n \times \beta$	3 x 120°	3 x 120°	3 x 120°	3 x 120°	6 x 60°
	γ	60°	60°	60°	60°	30°
	$L_{-0,2}$	39	46	55	67	80
	$l_{0,1}$	34	42	48	59	70
	l_1	15	18	23	26	35
	l_2	8,5	9,5	11,5	14	16
	l_3	15	17	20	24	30
	l_4	8,5	10	10	11,5	11,5
	l_5	2,5	3	3	3	3
actuator travel	min. l_6	1,1	1,2	1,3	1,6	1,9
	max. l_6	1,3	1,4	1,5	1,8	2,1
	l_7	10	12	12	15	20
	l_8	10	12	16	20	20

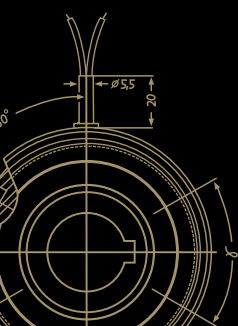

Pneumatic tooth brake - Type 679

Engagement plate

If in the the event of an overload the axial component from the torque is larger than the compressive force (spring force), the engaging ring will slip out of mesh. An engagement plate fitted to the brake operates a no-contact switch (proximity switch) and switches the brake off without any residual torque.

Compressed air feed

- nominal pressure between 4 and 5 bar
- the compressed air connection point is located on the circumference of the shifting ring, which is provided with a plug to protect against contamination
- compressed air connection and connection holes do not feature a precisely defined position to each other

Compressed air treatment



- treated compressed air with solid particle size of max. 40 µm
- to the standard ISO 8573-1 Class 5
- water and oil content must meet the same standard

Toothing geometries

Mönninghoff brakes offer a large variety of application-specific designs of toothing.

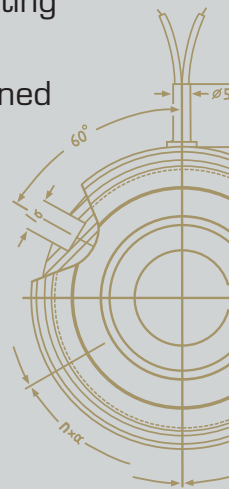
The amount of possible geometries or fixed points is endless and our engineers can help to design an optimized version at any time.

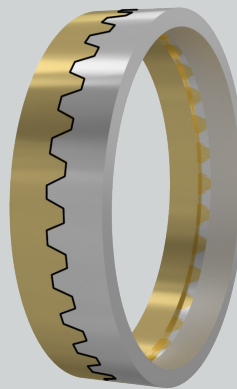

	<p>Standard</p> <ul style="list-style-type: none">• transmits torque in both directions with little backlash• also available backlash free• with increased flank angle also available as torque limiter with fixed position engagement	 <p>Saw (counter-) clockwise</p> <ul style="list-style-type: none">• transmits nominal torque in both directions• in reverse direction approx. 10% of torque can be transmitted• can be engaged at higher speeds
--	---	---

Pneumatic tooth brake - Type 679

Switching characteristics

They can be used in oil or dry operation without any major changes in the engagement properties provided there are oils available with a maximum viscosity of $25 \times 10^{-6} \text{m}^2/\text{s}$ at 50°C .

At a glance

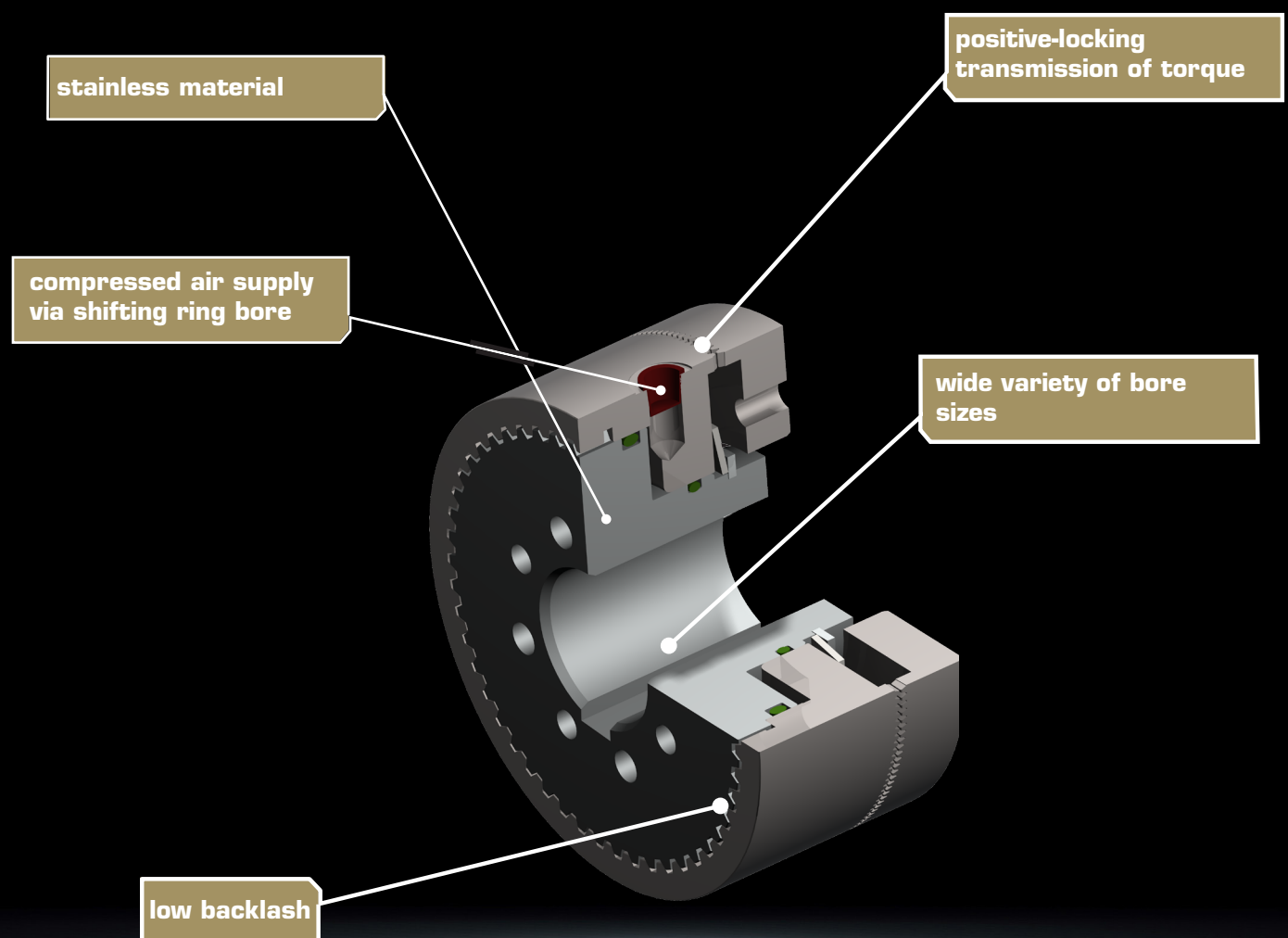

System solutions

You need more?

Mönninghoff clutches can be combined with a variety of many other power transmission elements. Such complex high-tech systems can solve any application-specific tasks and can fulfill any customer-specific wishes.

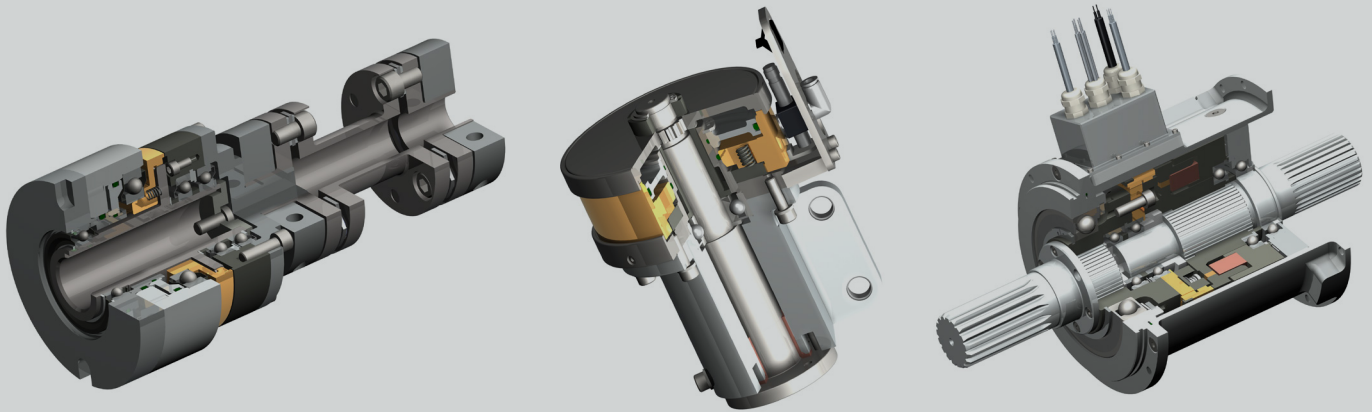

In many cases, a combination of different drive elements is needed to solve the applications particular problems and difficulties. Being not just supplier but technological partner to our customers, our extensive engineering is part of extraordinary and challenging power transmission projects.

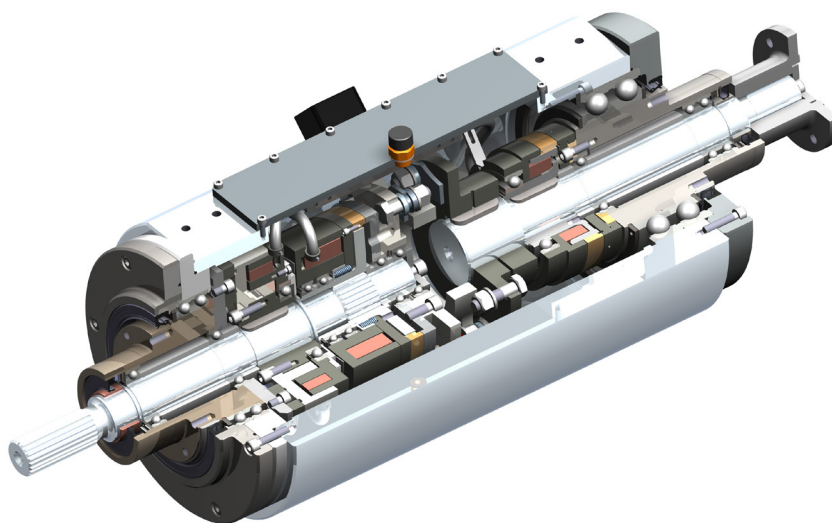

**Our product is the know-how,
with hardware as an added bonus.**

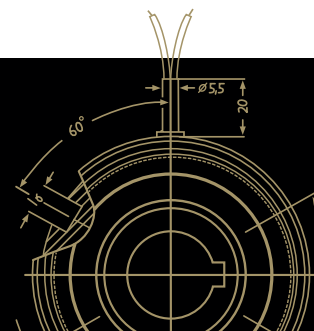

Driven by excellence

Why Mönninghoff

- intensive dialog with our customers' engineers
- decades of experience and competence
- deep understanding for all areas of mechanical engineering
- highly modern and flexible machine park
- enthusiasm for quality
- flexibility, inventiveness and communication skills of our employees
- commitment to Germany and Bochum as industrial location



Helps you find a customer-specific power transmission solution for extraordinary circumstances.



For the competent processing and smooth handling of your orders and delivery dates.



Feels committed to protect and preserve the high value of your machine and to secure its availability.

CHAIN & DRIVES®

WA LOCATIONS

Unit 1 / 45 Inspiration Drive, Wangara WA 6065
(08) 9303 4966

Unit 16 / 51-53 Kewdale Road, Welshpool WA 6106
(08) 6314 1155

support@chainanddrives.com.au

NSW LOCATION

Unit 7 / 70 Holbeche Road, Arndell Park NSW 2148
(02) 9674 8611

salesnsw@chainanddrives.com.au



A Mechanical Equipment Group Company