

Mönninghoff

**SecMatic torque
limiter
Type 587**

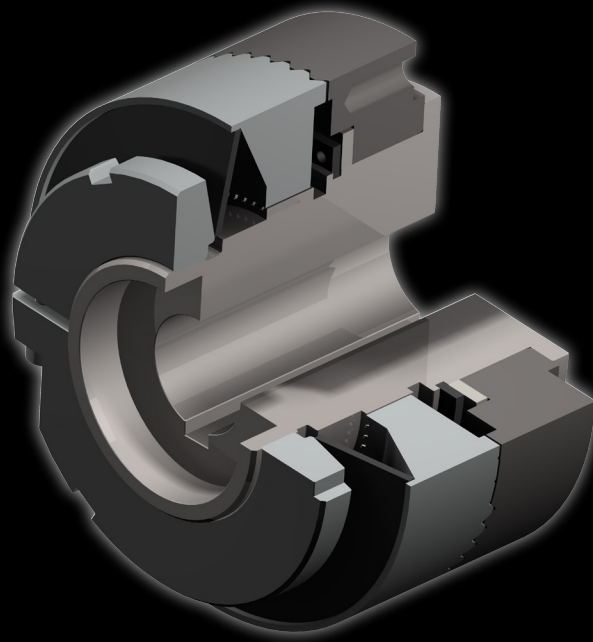

CHAIN & DRIVES
COMPLETE BEARINGS
& POWER TRANSMISSION

POWER > SPEED > TORQUE

SecMatic torque limiter - Type 587

Characteristics and features

- particularly developed for the increasing safety demands of high-tech systems
- extremely high switching accuracy for static and dynamic loads
- compact design allows easy integration
- special coating ensures consistent torque and a long service life
- slip-free torque transmission
- automatic re-engaging
- maintenance-free
- safe due to sealed design

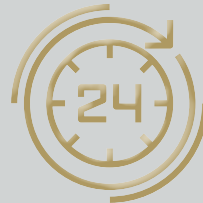

Mönninghoff power transmission represents an infinite variant diversity that is applied by all areas of modern mechanical engineering.

Our technologies are mostly designed to operate under extreme conditions. We offer high precision products for medical robotics, fail-proof security for aerospace technology or synchronization solutions for the packaging or printing industry.

We thus address customers who have the highest standards for their own machines or systems. To them, we can offer highly complex, application-specific solutions.

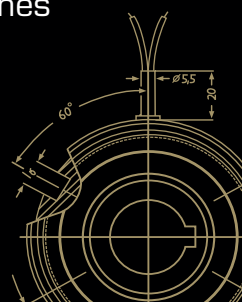

SecMatic torque limiter - Type 587

Match code

Mönninghoff SecMatic torque limiters are indicated by the following match code:

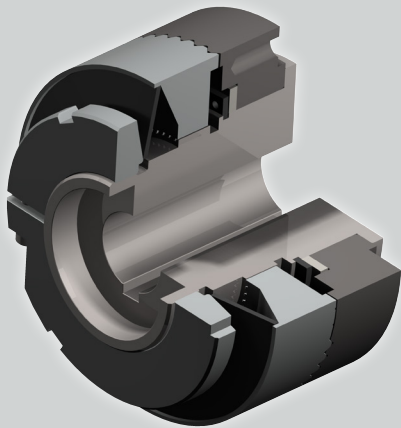

587 . A . 3 . B

- A** clutch size
- B** design of armature

Other individual characteristics:

- toothing geometries
- bore size with keyway

According to these characteristics, we design individual solutions concerning transmitted torque, engaging behavior or rotation speed.

Our engineers can assist with finding an application-specific clutch at any time. Together, we can develop individual and innovative solutions for extreme operating conditions.

Ordering Example

Mönninghoff SecMatic torque limiter
Type 587.23.3.5

Nominal torque T_K	200 Nm
Bore d	40 mm H7, keyway acc. to DIN 6885/1
Toothing	TwinArc, right

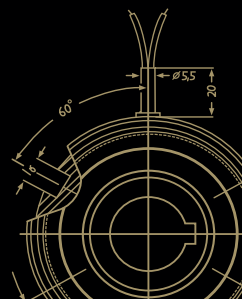

SecMatic torque limiter - Type 587

Clutch size

When dimensioning a Mönninghoff SecMatic torque limiter, several technical preconditions should be considered:

- the overload torque should be at least 20% larger than the average torque
- for the selection of the correct size, not only the peak load but also the dynamic behavior of the drive have to be taken into account, especially for starting or slowing down
- generally, the selection of the correct clutch is based on torque:

$$T_K = (T_a + T_L) \times K \quad [\text{Nm}]$$

T_K	=	overload torque
T_a	=	starting torque
T_L	=	load torque
K	=	service factor 1,2 to 3

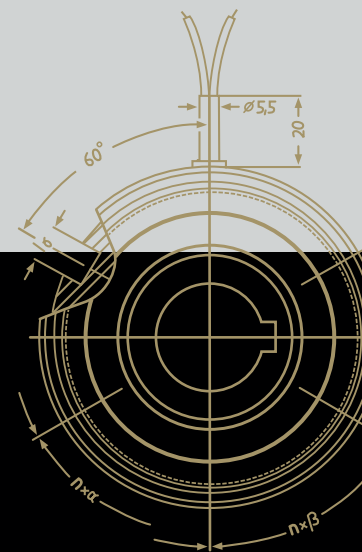

SecMatic torque limiter - Type 587

Clutch size

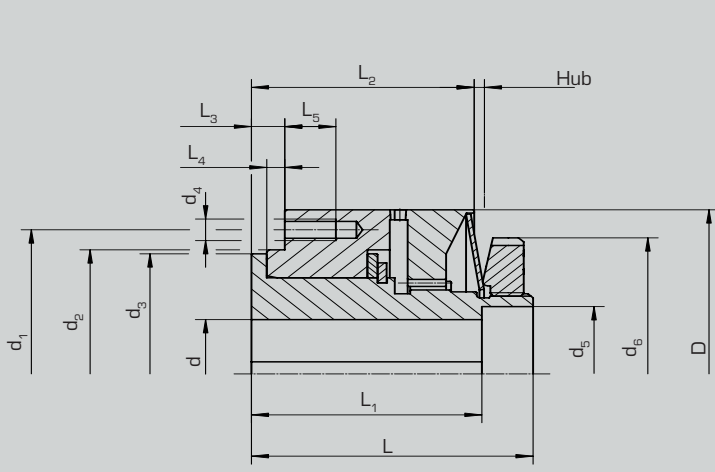

Design 3.1

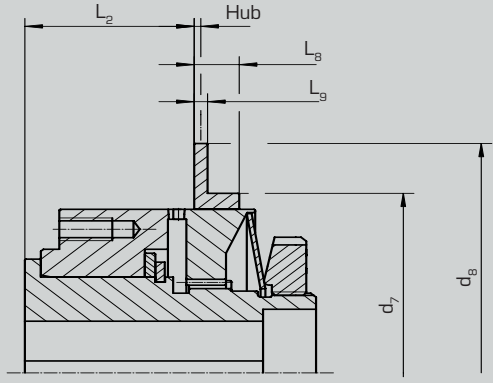

Design 3.5 with switch plate

Technische Daten

Size		12	13	15	21	23	25	31	32	
torque	T_{K1} [Nm]	5 - 30	10 - 60	25 - 120	50 - 225	100 - 450	200 - 900	400 - 1800	800 - 2400	
max. speed	n [min ⁻¹]	250								
inertia	design 3.1	0,36	0,53	1,03	2,43	5,62	12	34,2	62,5	
	design 3.5	0,44	0,63	1,37	3,17	7,4	14,85	40,2	82,4	
weight	design 3.1	0,82	0,92	1,44	2,2	3,6	5,8	9,9	13,5	
	design 3.5	0,88	0,98	1,54	2,4	4	6,3	10,5	15,2	
stroke	[mm]	0,53	0,69	0,8	0,9	1,02	1,27	1,6	1,9	
bore H7	keyway acc. to DIN 6885/1	d min.	8	10	12	14	18	24	28	45
		d max.	12	15	22	30	40	45	65	80
	keyway acc. to DIN 6885/3	d max.	15	18	25	35	45	50	70	85
dimensions	D	[mm]	57	67	82	95	114	134	166	195
	d ₁		50	57	72	85	101	117	148	172
	d ₂ H7		42	47	62	75	90	100	130	150
	d ₃		40	45	60	72	86	96	128	148
	d ₄	6 x 60°	M4	M5	M5	M6	M8	M10	M12	M12
	d ₅		20	23	30	41	51	56	85	104
	d ₆		45	56	68	80	95	110	140	160
	d ₇		64	74	90	107	126	146	178	215
	d ₈		85	90	115	130	165	185	218	250
	L		45	47	55	67	72	87	95	106
	L ₁		38	40	45	55	60	75	80	90
L ₂		37	37	44	52	57	68	76	88	
L ₃		6	6	6,5	7	8	9	11	13	
L ₄		2,7	2,7	2,7	2,7	3,7	3,7	4,5	8	
L ₅		8	8	10	10	12	15	20	20	
L ₇		28	28	32	38	42	50	55	62	
L ₈		6	6	8,5	10	10	11,5	11,5	16	
L ₉		2	2	2,5	3	3	3	3	6	

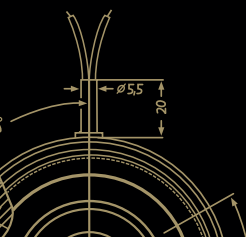

SecMatic torque limiter - Type 587

Belleville spring

An important characteristic of the SecMatic torque limiter is the special belleville spring, which has a negative characteristic in the operating range

- i.e the axial force of the spring decreases on disengagement
- as a result the tooth flank can be straight

Toothing

The SecMatic Type 587 is a reengaging clutch, which slides into the engagement position on every revolution

- fixedpoint shifting is mandatory at one position whilst in serveral positions it is possible to a certain extent
- operating speeds are limited
- matching the shape of tooth to the particular spring element used prevents microscopic movements of the clutch under critical load and fretting corrosion

Special feature: TwinArc-toothform

- makes it possible to transfer different torques in both direction of rotation owing to extremely different flank angles
- only available with single position engagement
- when ordering, the required direction of drive must be specified

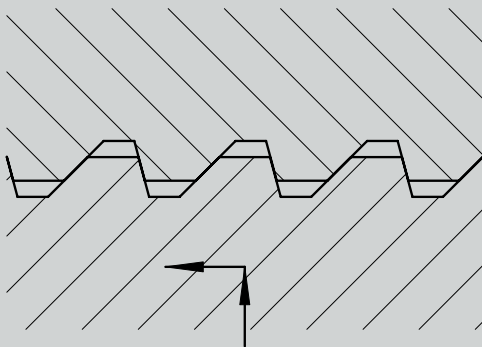

TwinArc clockwise

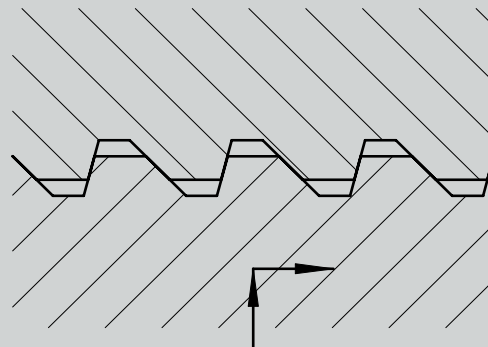

TwinArc counter clockwise

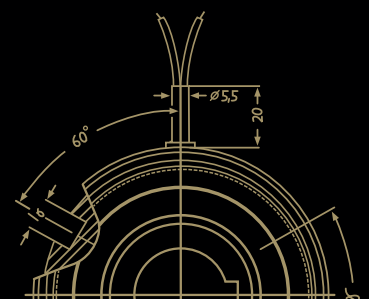

SecMatic torque limiter - Type 587

At a glance

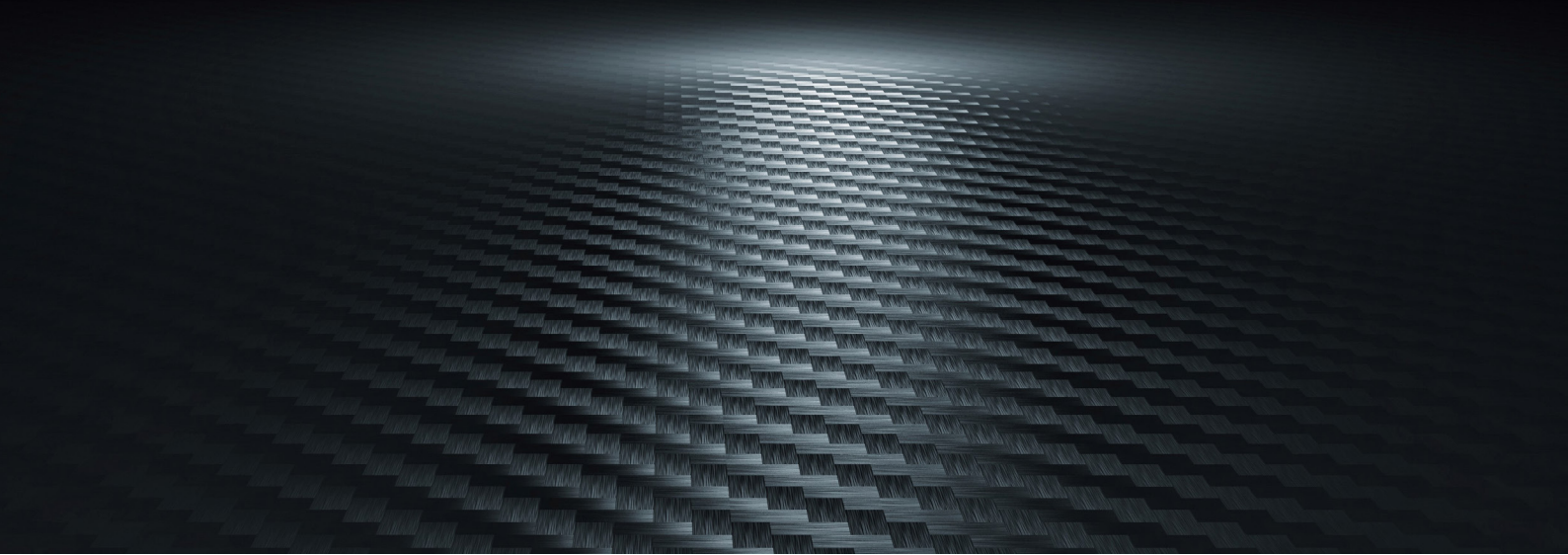
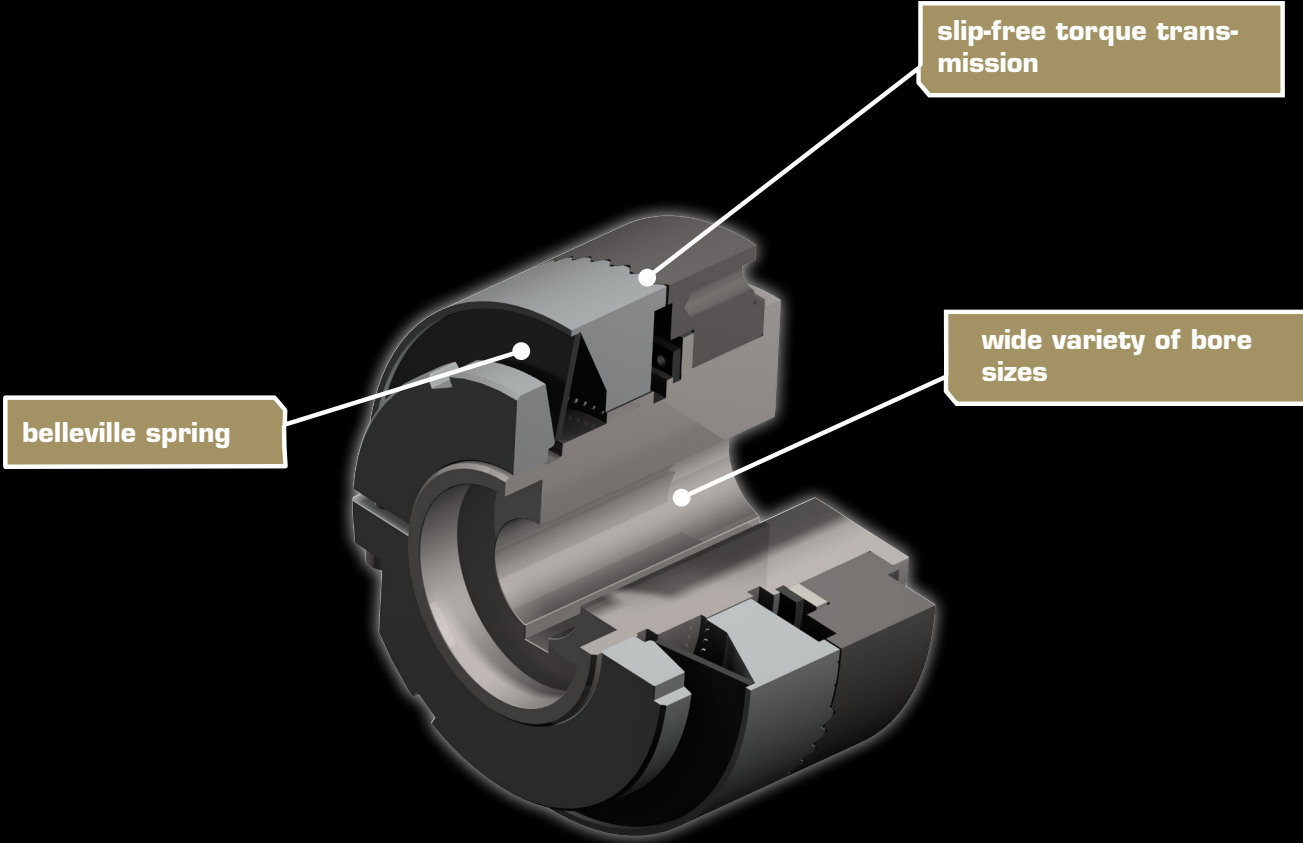

System solutions

You need more?

Mönninghoff clutches can be combined with a variety of many other power transmission elements. Such complex high-tech systems can solve any application-specific tasks and can fulfill any customer-specific wishes.

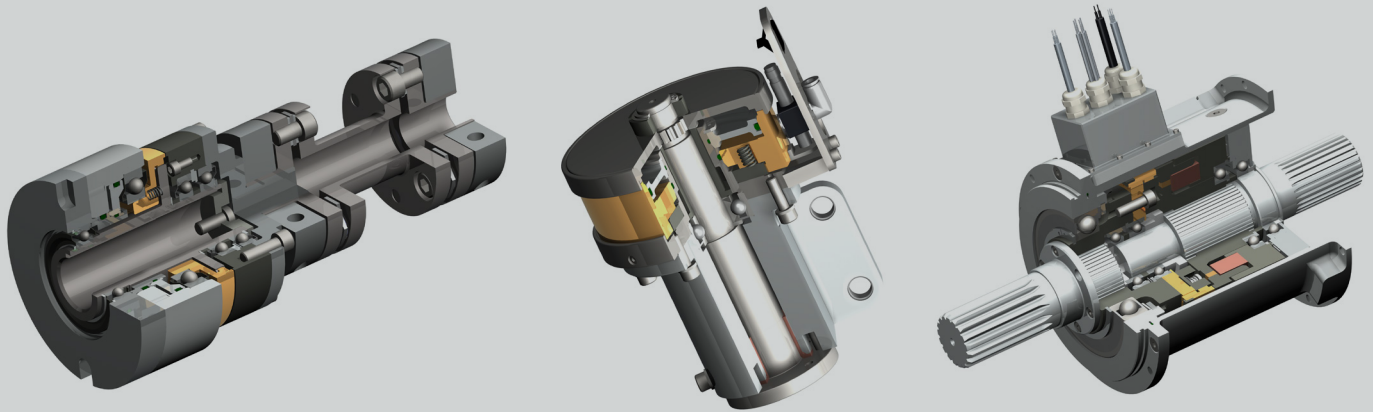

In many cases, a combination of different drive elements is needed to solve the applications particular problems and difficulties. Being not just supplier but technological partner to our customers, our extensive engineering is part of extraordinary and challenging power transmission projects.

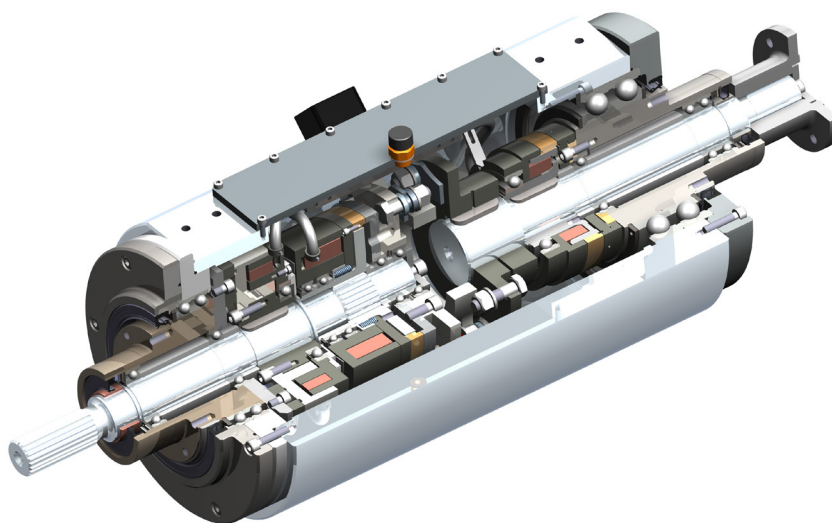

**Our product is the know-how,
with hardware as an added bonus.**

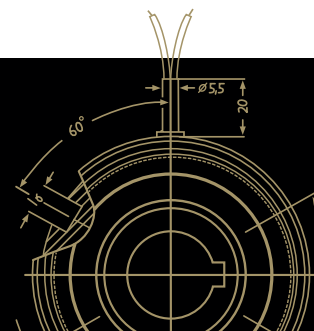

Driven by excellence

Why Mönninghoff

- intensive dialog with our customers' engineers
- decades of experience and competence
- deep understanding for all areas of mechanical engineering
- highly modern and flexible machine park
- enthusiasm for quality
- flexibility, inventiveness and communication skills of our employees
- commitment to Germany and Bochum as industrial location



Helps you find a customer-specific power transmission solution for extraordinary circumstances.



For the competent processing and smooth handling of your orders and delivery dates.



Feels committed to protect and preserve the high value of your machine and to secure its availability.

CHAIN & DRIVES®

WA LOCATIONS

Unit 1 / 45 Inspiration Drive, Wangara WA 6065
(08) 9303 4966

Unit 16 / 51-53 Kewdale Road, Welshpool WA 6106
(08) 6314 1155

support@chainanddrives.com.au

NSW LOCATION

Unit 7 / 70 Holbeche Road, Arndell Park NSW 2148
(02) 9674 8611

salesnsw@chainanddrives.com.au



A Mechanical Equipment Group Company