

Mönninghoff

Bistable tooth clutch

Type 556

M1

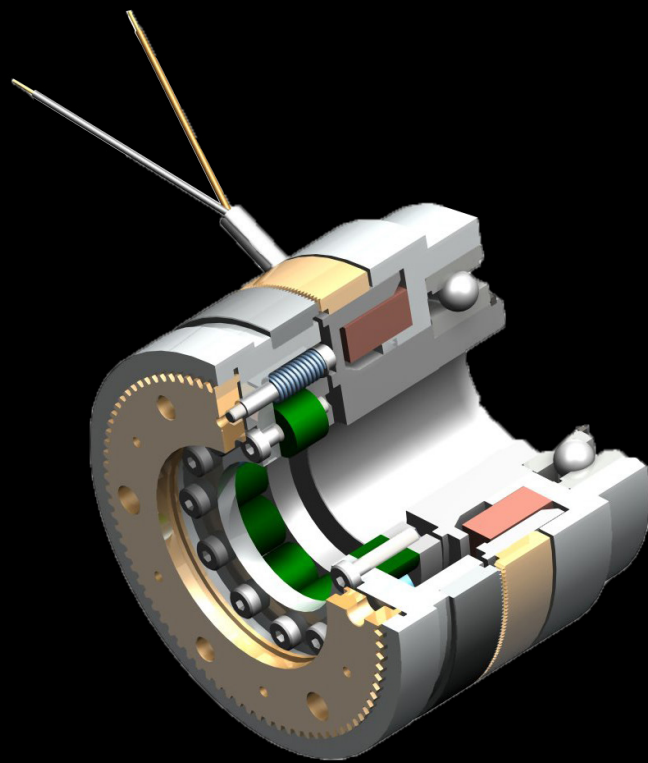

CHAIN & DRIVES[®]
COMPLETE BEARINGS
& POWER TRANSMISSION

POWER > SPEED > TORQUE

Bistable tooth clutch - Type 556 M1

Characteristics and features

- up to 99% energy savings and low emission
- highest level of safety and no unintended opening or closing during power off
- short current pulse to change the switch position
- keeps the position currentless
- slip-free, form-locking transmission of torque
- engageable at low relative speed
- short cycle times
- detection of switching position can be monitored with standard sensor
- application-related customized toothing geometry
- also available as bistable tooth brake
- integrated, easy-to-assemble system solution
- free release in case of overload
- unique and patented (DE 10 2014 110 117)



Mönninghoff power transmission represents an infinite variant diversity that is applied by all areas of modern mechanical engineering.

Our technologies are mostly designed to operate under extreme conditions. We offer high precision products for medical robotics, fail-proof security for aerospace technology or synchronization solutions for the packaging or printing industry.

We thus address customers who have the highest standards for their own machines or systems. To them, we can offer highly complex, application-specific solutions.

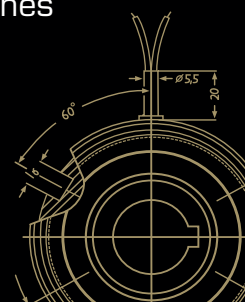

Bistable tooth clutch - Type 556 M1

Match code

Mönninghoff bistable tooth clutches are indicated by the following match code:

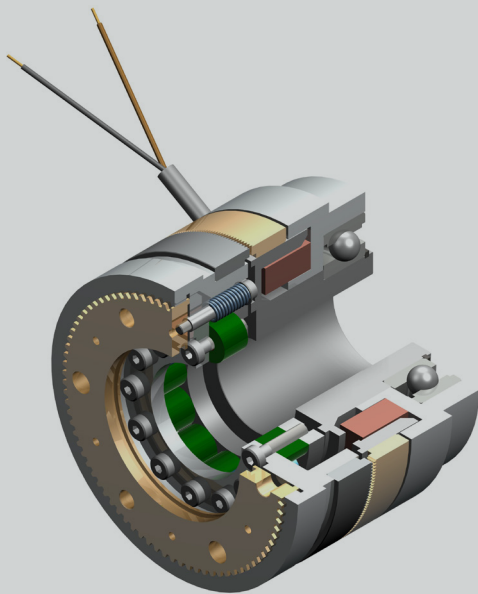

556 . A . B

- A** clutch size
- B** design of stator

Other individual characteristics:

- tothing geometry
- voltage
- bore size with keyway

According to these characteristics, we design individual solutions concerning transmitted torque, engaging behavior or rotation speed.

Our engineers can assist with finding an application-specific clutch at any time. Together, we can develop individual and innovative solutions for extreme operating conditions.

Ordering example

Mönninghoff bistable electromagnetic tooth clutch
Type 556.21.3

tothing	standard, no single position
voltage	24 Vdc
bore size d	20 mm H7, keyway acc. to DIN 6885/1

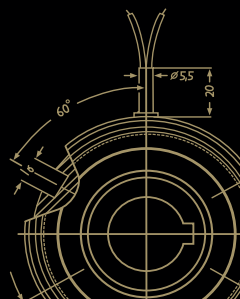

Bistable tooth clutch - Type 556 M1

Clutch size

When dimensioning a Mönninghoff tooth clutch, several technical preconditions should be considered:

- for the selection of the correct size, not only the peak load but also the dynamic behavior of the drive have to be taken into account
- tooth clutches - contrary to friction clutches - must never be overloaded and safety factors must be considered
- generally, the selection of the right clutch is based on torque:

$$M = 9550 \frac{P}{n} \cdot K \text{ [Nm]}$$

$$M = (M_L + M_B) \cdot K \text{ [Nm]}$$

- the transmittable torque of the clutch must always be higher than the largest possible occurring torque:

$$\text{Requirement } M_{\ddot{U}} > M$$

- P = power of motor [kW]
 n = rotating speed [min^{-1}]
 K = safety factor 1,5 ... 2,5
 M = required torque
 M_L = load torque
 M_B = acceleration torque
 $M_{\ddot{U}}$ = nominal torque of clutch (see enclosed chart)

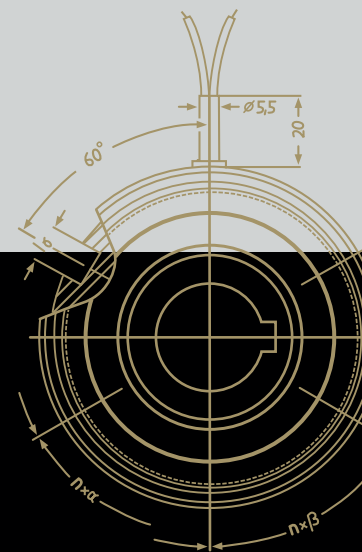

Bistable tooth clutch - Type 556 M1

Clutch size

Also available as a special design are stator type 1 (flange mounted with flying leads), type 2 (flange mounted with plug and socket) and type 4 (bearing mounted with plug and socket).

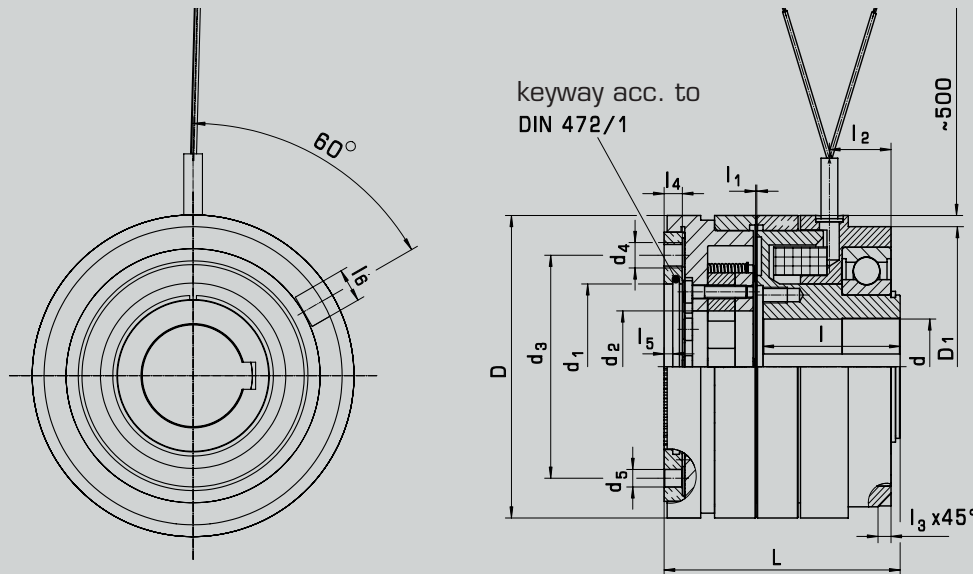

Type 3, bearing mounted with flying leads

Technical data

Size		15	21	23	
torque	[Nm]	50	100	250	
max. speed dry running	[1/min]	1000	1000	1000	
input power	[W]	98,8	116	164,6	
number of teeth		260	290	280	
dimensions	D	[mm]	82	95	114
	D ₁		75	88	105
	d H7		10...25	20...32	25...40
	d ₁ H7		42	52	62
	d ₂		25,5	35	51
	d ₃		60	70	80
	d ₄		M6 (3 x 120°)	M8 (3 x 120°)	M8 (3 x 120°)
	d ₅		4,5 (3 x 120°)	5,5 (3 x 120°)	7,8 (3 x 120°)
	L		71,8	77,5	85
	l		42	45	50
	l ₁ ±0,1		0,3	0,4	0,4
	l ₂		18	20	24
	l ₃		6	6	6
	l ₄		4,6	6	6,5
	l ₅		4,05	5	5,5
	l ₆		8	10	10

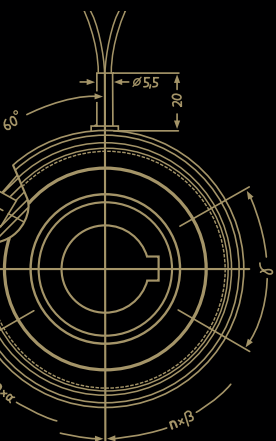

Bistable tooth clutch - Type 556 M1

Toothing geometries

Mönninghoff clutches offer a large variety of application-specific designs of toothing.

The amount of possible geometries or fixed points is endless and our engineers can help to design an optimized version at any time.

Toothing examples

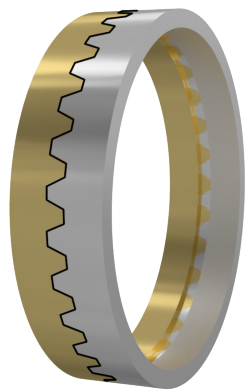

Standard

- transmits torque clockwise or counter-clockwise with little backlash
- also available backlash free
- with increased flank angle also available as torque limiter with fixed position engagement



Spaced

- transmits torque clockwise or counter-clockwise with large amount of backlash
- can be engaged at higher speeds



Saw (counter-) clockwise

- transmits nominal torque clockwise or counter-clockwise
- in reverse direction only 10% of torque can be transmitted
- can be engaged at higher speeds



Stepped (counter-) clockwise

- transmits nominal torque clockwise or counter-clockwise
- in reverse direction only 20% of torque can be transmitted with little backlash
- can be engaged at higher speeds

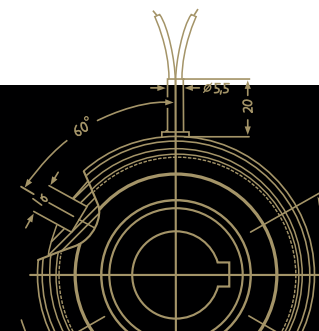

Bistable tooth clutch - Type 556 M1

Technical features

- carefully designed combination of electromagnetic coil, permanent magnets and pressure springs
- for detection of switching position, there is a slot on the armature of the clutch that can be monitored by a standard sensor
- force of the permanent magnets is designed to also transmit the nominal torque of clutch
- only a short current pulse is needed to change the switch position

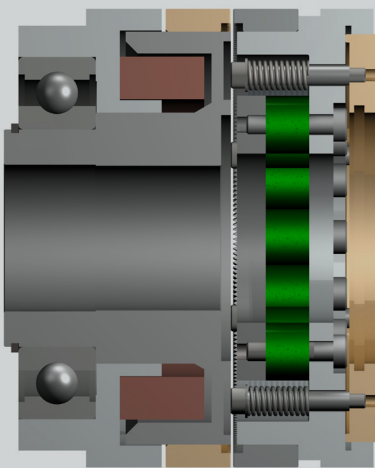

1. Clutch disengaged:
spring force

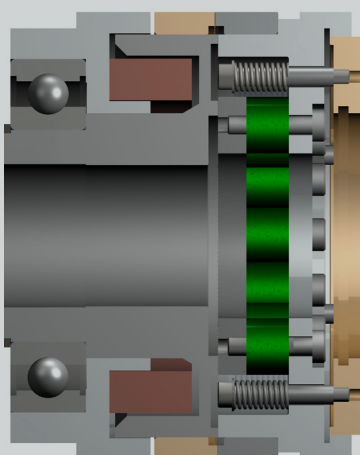

2. Clutch engages:
combination of permanent- and electro-
magnetic force through short current pulse
3. Clutch remains engaged:
permanent magnets hold clutch engaged
4. Clutch disengages:
electromagnetic force after short current pulse on
electromagnetic coil (polarity reversal)

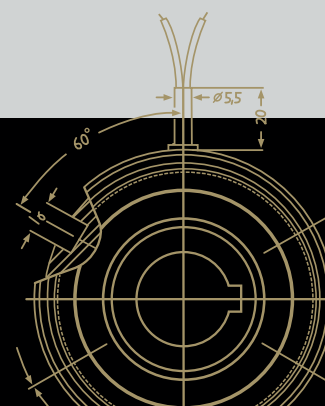

Bistable tooth clutch - Type 556 M1

Voltage

- standard voltage is 24 Vdc
- special voltages between 6 and 196 Vdc on request
- the permissible voltage tolerance is -10% to +5% according to VDE 0580
- in order to avoid induced voltage peaks, it is recommended to use varistors at high switching frequencies

At a glance

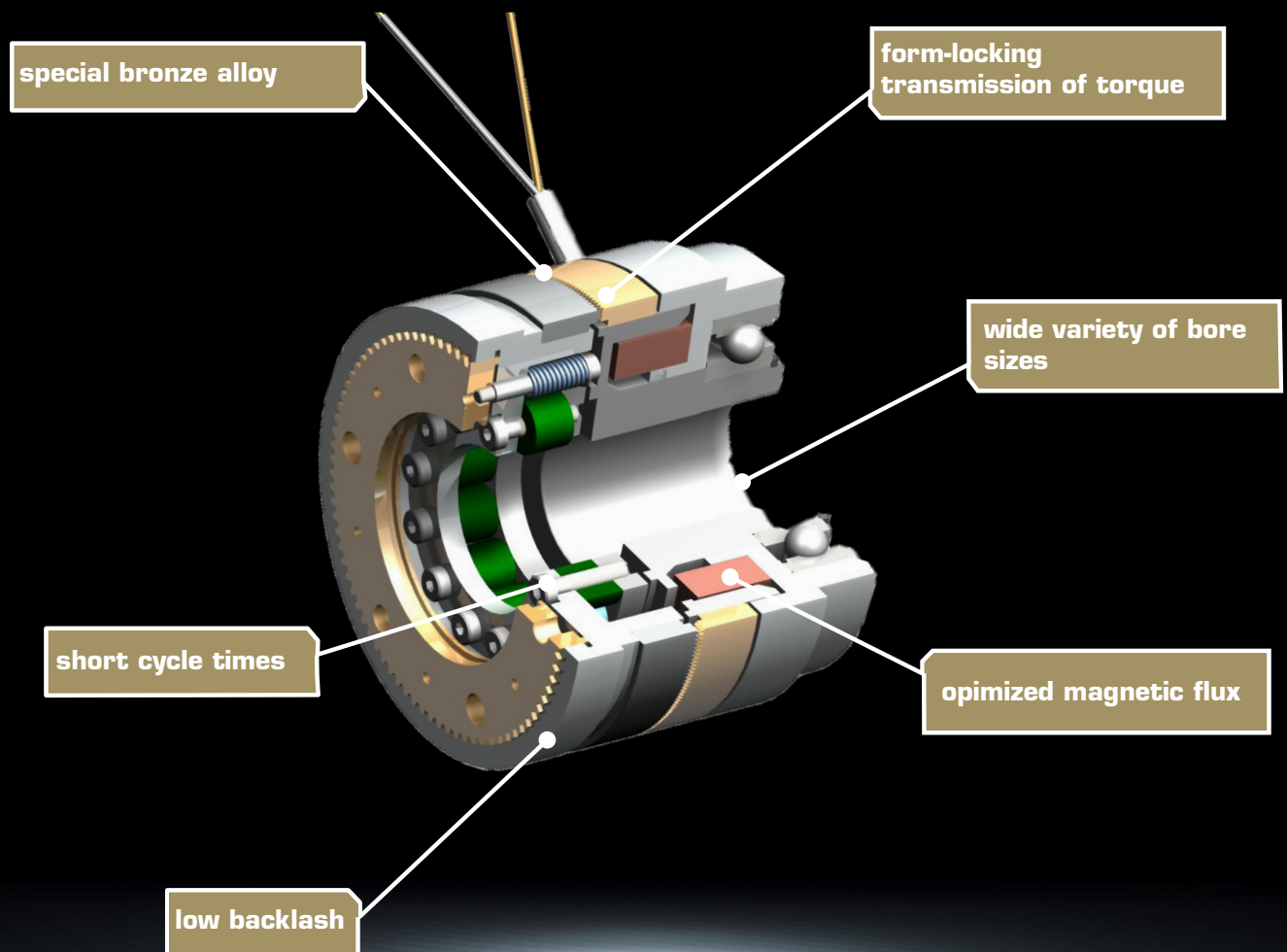

System solutions

You need more?

Mönninghoff clutches can be combined with a variety of many other power transmission elements. Such complex high-tech systems can solve any application-specific tasks and can fulfill any customer-specific wishes.

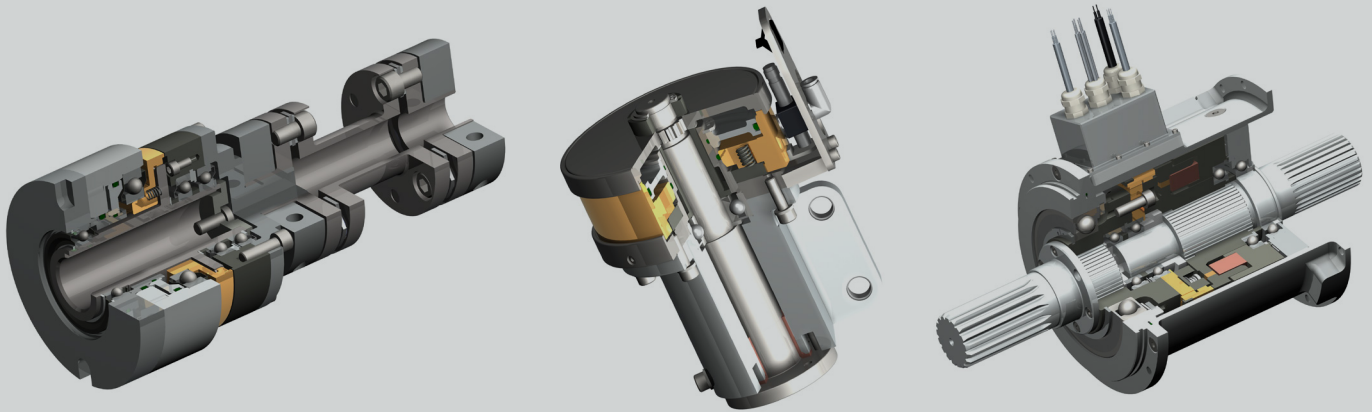

In many cases, a combination of different drive elements is needed to solve the applications particular problems and difficulties. Being not just supplier but technological partner to our customers, our extensive engineering is part of extraordinary and challenging power transmission projects.

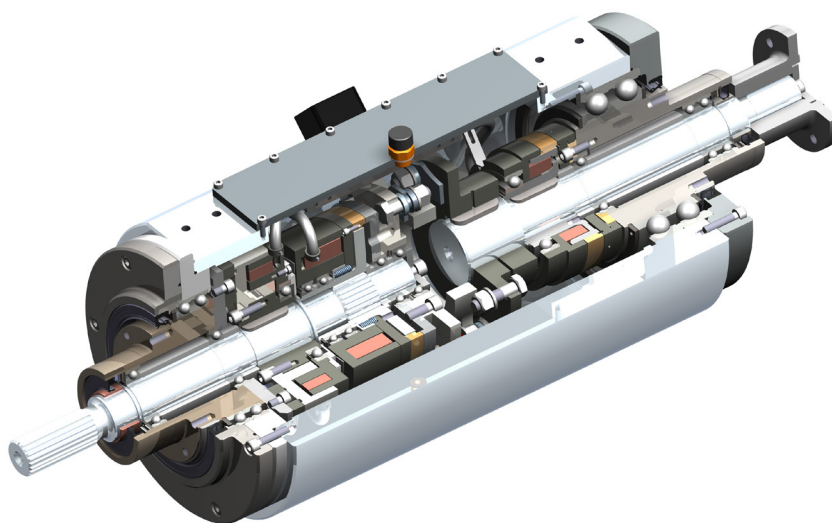

**Our product is the know-how,
with hardware as an added bonus.**

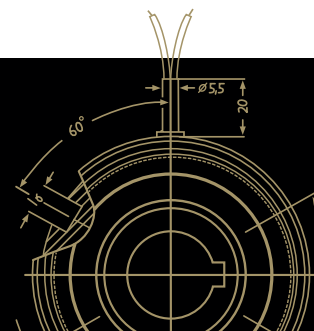

Driven by excellence

Why Mönninghoff

- intensive dialog with our customers' engineers
- decades of experience and competence
- deep understanding for all areas of mechanical engineering
- highly modern and flexible machine park
- enthusiasm for quality
- flexibility, inventiveness and communication skills of our employees
- commitment to Germany and Bochum as industrial location



Helps you find a customer-specific power transmission solution for extraordinary circumstances.



For the competent processing and smooth handling of your orders and delivery dates.



Feels committed to protect and preserve the high value of your machine and to secure its availability.

CHAIN & DRIVES®

WA LOCATIONS

Unit 1 / 45 Inspiration Drive, Wangara WA 6065
(08) 9303 4966

Unit 16 / 51-53 Kewdale Road, Welshpool WA 6106
(08) 6314 1155

support@chainanddrives.com.au

NSW LOCATION

Unit 7 / 70 Holbeche Road, Arndell Park NSW 2148
(02) 9674 8611

salesnsw@chainanddrives.com.au



A Mechanical Equipment Group Company