

Mönninghoff

Electromagnetic spring-applied tooth clutch Type 548

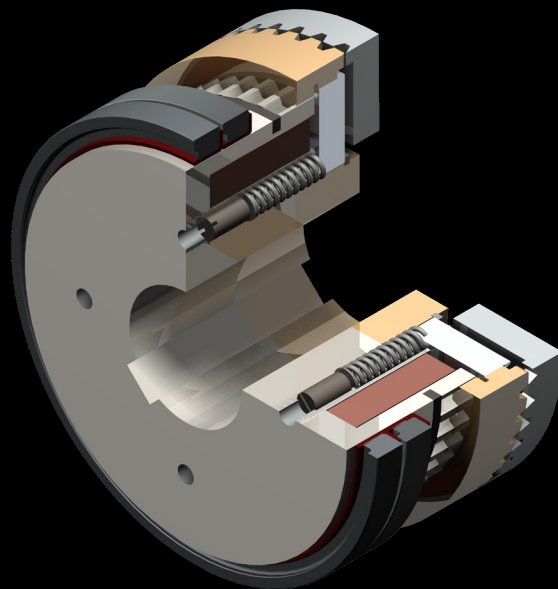

CHAIN & DRIVES
COMPLETE BEARINGS
& POWER TRANSMISSION

POWER > SPEED > TORQUE

Electromagnetic spring-applied tooth clutch - Type 548

Characteristics and features

- high torque transfer despite compact dimensions
- form-locking transmission of torque without slip
- engageable also at low relative speed
- operating at high range of temperatures
- easy control via direct current
- anti-magnetic toothing for optimized magnetic flux
- application-related customized tooth geometries
- short cycle times
- current supply with two slip rings
- oil running or dry running
- synchronized switching with fixed engagement positions
- offers uncompromised safety and reliability
- integrated, easy-to-assemble system solution
- condition monitoring on demand



Mönninghoff power transmission represents an infinite variant diversity that is applied by all areas of modern mechanical engineering.

Our technologies are mostly designed to operate under extreme conditions. We offer high precision products for medical robotics, fail-proof security for aerospace technology or synchronization solutions for the packaging or printing industry.

We thus address customers who have the highest standards for their own machines or systems. To them, we can offer highly complex, application-specific solutions.

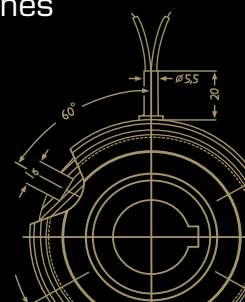

Electromagnetic spring-applied tooth clutch - Type 548

Match code

Mönninghoff spring-applied tooth clutches are indicated by the following match code:

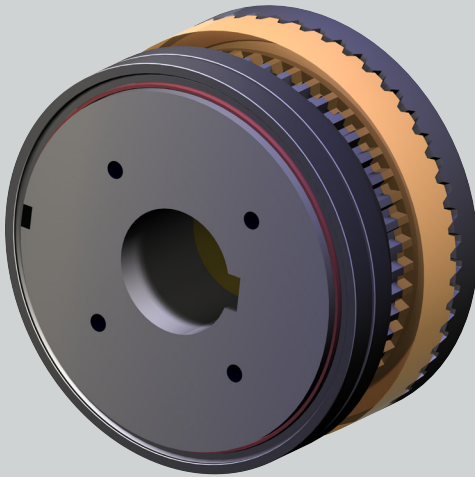

548 . A . 2 . 1

A clutch size

Other individual characteristics:

- tothing geometry
- voltage
- bore size with keyway

According to these characteristics, we design individual solutions concerning transmitted torque, engaging behavior or rotation speed.

Our engineers can assist with finding an application-specific clutch at any time. Together, we can develop individual and innovative solutions for extreme operating conditions.

Ordering example

Mönninghoff spring-applied tooth brake
Type 548.14.2.1

tothing	standard
voltage	24 Vdc
bore size d	20 mm H7, keyway acc. to DIN 6885/1

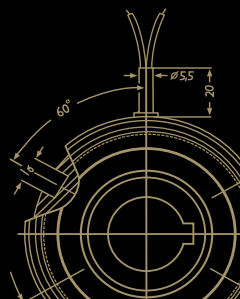

Electromagnetic spring-applied tooth clutch - Type 548

Clutch size

When dimensioning a Mönninghoff tooth clutch, several technical preconditions should be considered:

- for the selection of the correct size, not only the peak load but also the dynamic behavior of the drive have to be taken into account
- tooth clutches - contrary to friction clutches - must never be overloaded and safety factors must be considered
- generally, the selection of the correct clutch is based on torque:

$$M = 9550 \frac{P}{n} \cdot K \text{ [Nm]}$$

$$M = (M_L + M_B) \cdot K \text{ [Nm]}$$

- the transmittable torque of the clutch must always be higher than the largest possible occurring torque:

$$\text{Requirement } M_{\ddot{U}} > M$$

- P = power of motor [kW]
 n = rotating speed [min^{-1}]
 K = safety factor 1,5 ... 2,5
 M = required torque
 M_L = load torque
 M_B = acceleration torque
 $M_{\ddot{U}}$ = nominal torque of clutch (see enclosed chart)

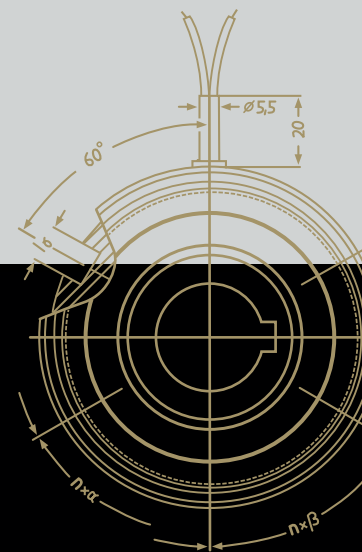

Electromagnetic spring-applied tooth clutch - Type 548

Clutch size

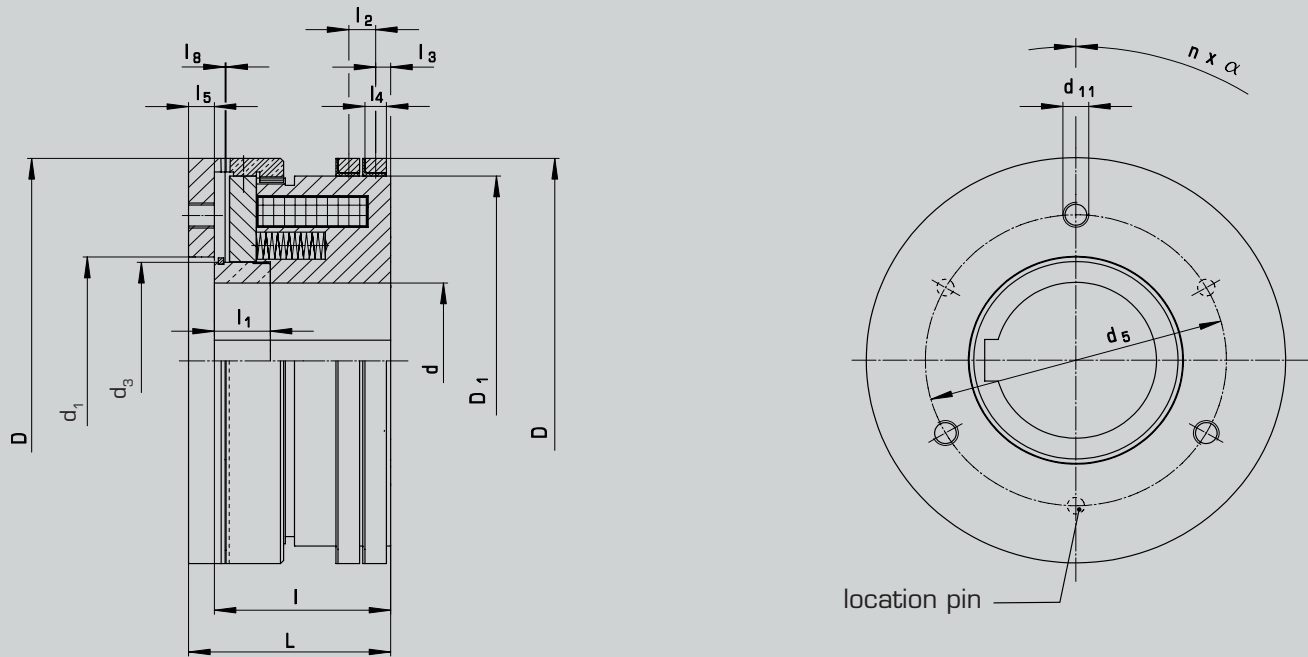

Spring-applied clutch with two slip rings

Technical data

Size		08	14	17	22	23	31	32	
torque	[Nm]	10	40	80	180	350	1000	2200	
max. speed	[min ⁻¹]	4500	3600	3000	2500	2100	1800	1400	
input power	[W]	18,6	38,8	58	81,5	100,6	162,1	195,1	
spring force	[N]	90	200	450	650	850	2300	5700	
number of teeth	normal	260	388	392	356	195	301	220	
	saw	30	36	38	40	40	-	-	
bore d ^{H7}	keyway acc. to DIN 6885/1	min.	10	15	15	20	25	47	65
		max.	15	32	40	45	60	75	85
	keyway acc. to DIN 6885/1	max.	-	35	-	-	-	-	-
dimensions	D	[mm]	67	95	114	134	166	195	240
	D ₁		70	85,5	100	120	150	178	218
	d ₁ H7		32	52	62	70	90	100	120
	d ₃		24	45	55	60	80	95	101,7
	d ₅		46	70	80	95	120	140	150
	d ₁₁	vvv	M5	M8	M12	M12	M12	M12	M12
	L		38	51	60	65	78	94	117
	l _{0,1}		34	46	54	60	68	82	101
	l ₁		13	20	20	25	24,5	26	31
	l ₂		10	10	9	12	12,5	12,5	14,5
l ₃		5	6,5	6,5	8	7	7	8	
l ₄		6	8	8	10	10	10	10	
l ₅		5	6,5	8	8	10	12	16	
l _{8-0,1}		0,2	0,2	0,2	0,3	0,3	0,4	0,4	

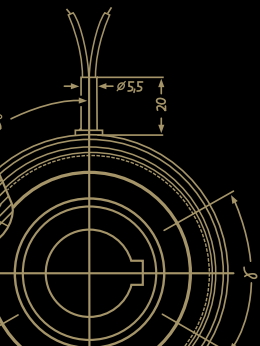

Electromagnetic spring-applied tooth clutch - Type 548

Toothing geometries

Mönninghoff clutches offer a large variety of application-specific designs of toothing.

The amount of possible geometries or fixed points is endless and our engineers can help to design an optimized version at any time.

Toothing examples



Standard

- transmits torque in both directions with little backlash
- also available backlash free
- with increased flank angle also available as torque limiter with fixed position engagement



Saw - left / right

- transmits nominal torque clockwise or counter-clockwise
- in reverse direction about 10% of torque can be transmitted
- can be engaged at higher speeds

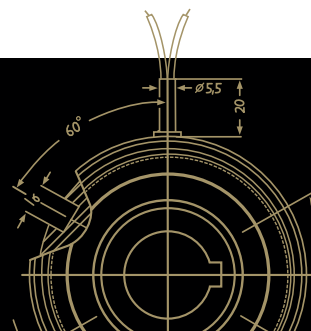

Electromagnetic spring-applied tooth clutch - Type 548

Voltage

- standard voltage is 24 Vdc
- special voltages between 6 and 196 Vdc on request
- spring applied (normally on)
- the permissible voltage tolerance is -10% to +5% according to VDE 0580
- in order to avoid induced voltage peaks, it is recommended to use varistors at high switching frequencies
- to ensure fast and safe release, it is recommended to pulse the coil with a high d.c. voltage

At a glance

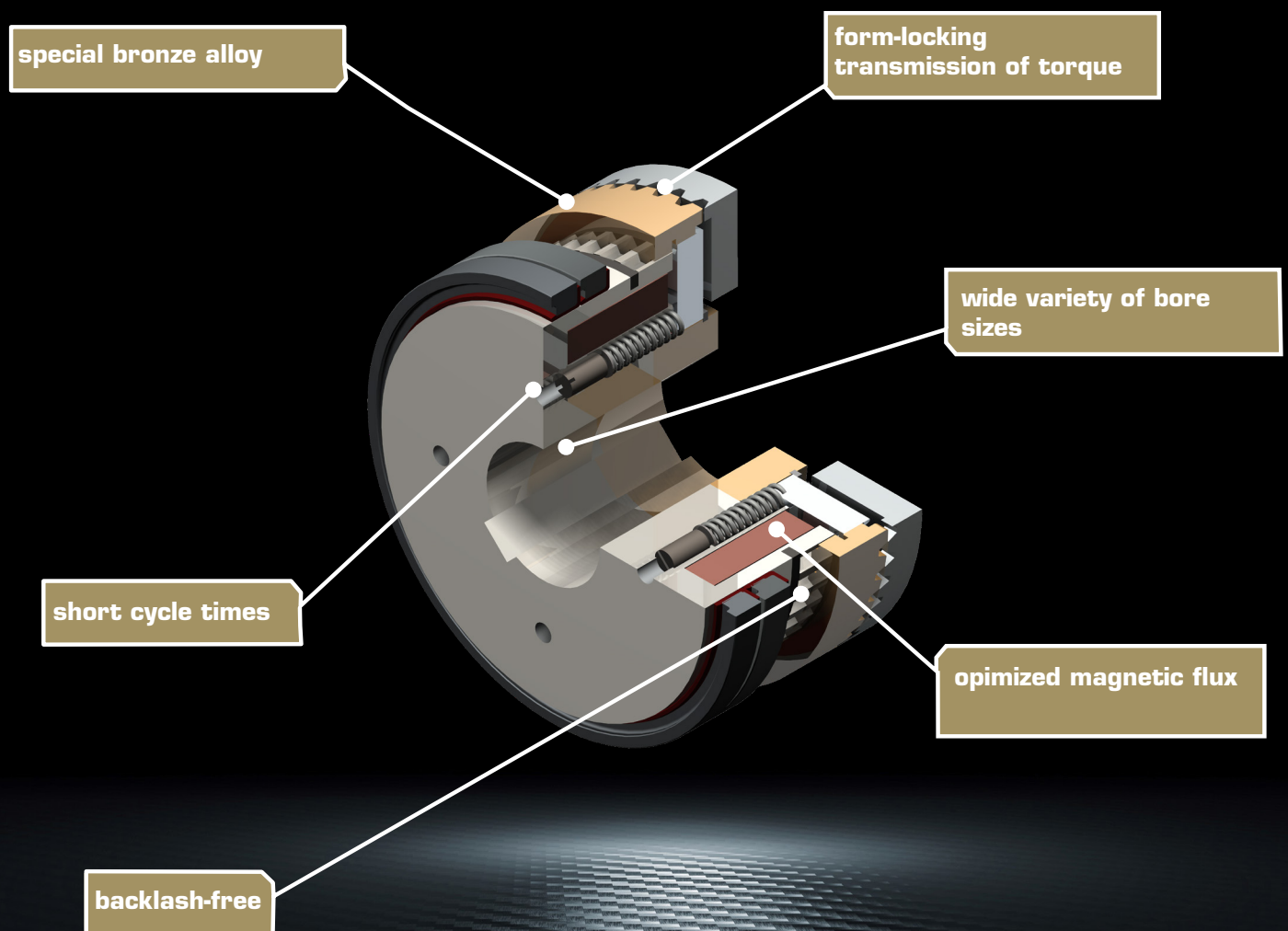

System solutions

You need more?

Mönninghoff clutches can be combined with a variety of many other power transmission elements. Such complex high-tech systems can solve any application-specific tasks and can fulfill any customer-specific wishes.

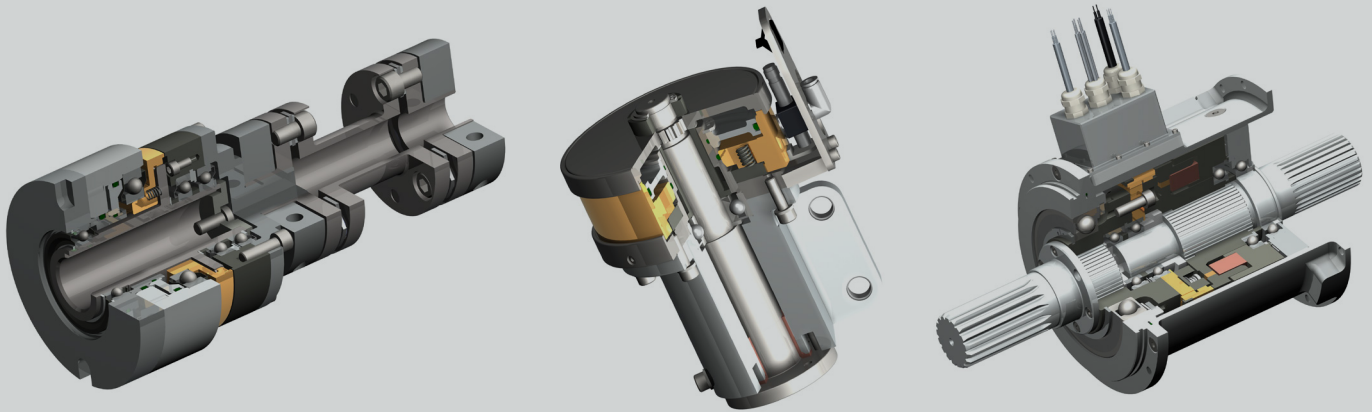

In many cases, a combination of different drive elements is needed to solve the applications particular problems and difficulties. Being not just supplier but technological partner to our customers, our extensive engineering is part of extraordinary and challenging power transmission projects.

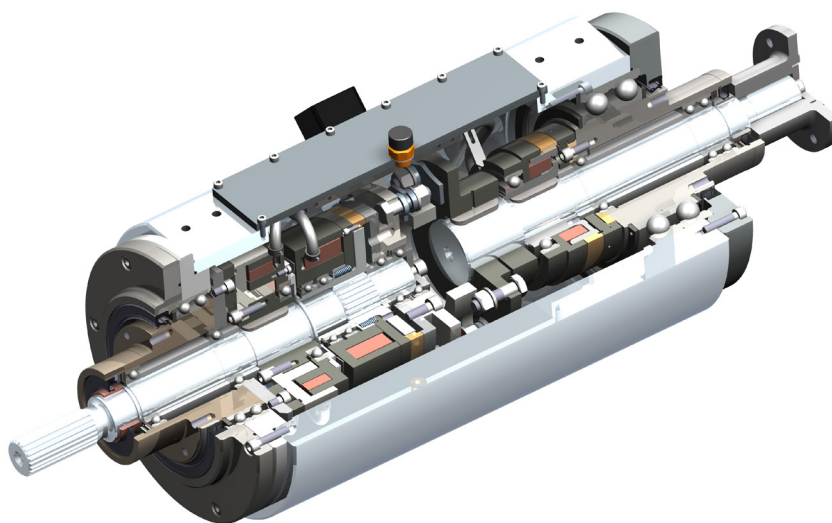

**Our product is the know-how,
with hardware as an added bonus.**

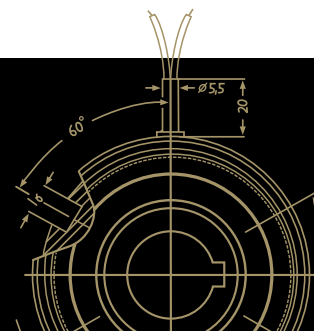

Driven by excellence

Why Mönninghoff

- intensive dialog with our customers' engineers
- decades of experience and competence
- deep understanding for all areas of mechanical engineering
- highly modern and flexible machine park
- enthusiasm for quality
- flexibility, inventiveness and communication skills of our employees
- commitment to Germany and Bochum as industrial location



Helps you find a customer-specific power transmission solution for extraordinary circumstances.



For the competent processing and smooth handling of your orders and delivery dates.



Feels committed to protect and preserve the high value of your machine and to secure its availability.



WA LOCATIONS

Unit 1 / 45 Inspiration Drive, Wangara WA 6065
(08) 9303 4966

Unit 16 / 51-53 Kewdale Road, Welshpool WA 6106
(08) 6314 1155

support@chainanddrives.com.au

NSW LOCATION

Unit 7 / 70 Holbeche Road, Arndell Park NSW 2148
(02) 9674 8611

salesnsw@chainanddrives.com.au



A Mechanical Equipment Group Company