

**Mönninghoff**

# Electromagnetic tooth clutch Type 543

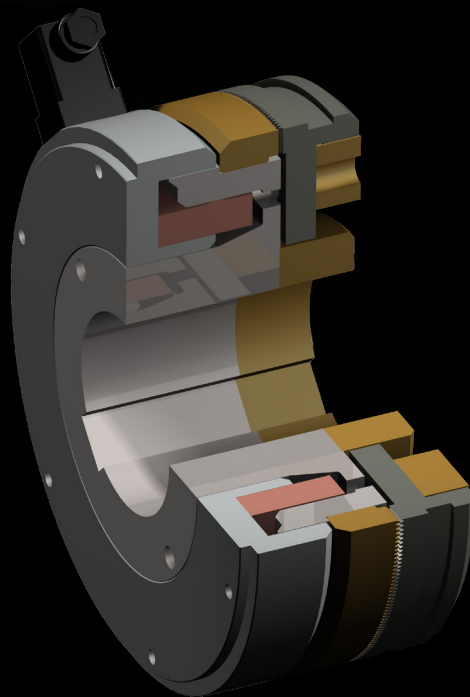

**CHAIN & DRIVES**  
COMPLETE BEARINGS  
& POWER TRANSMISSION

POWER > SPEED > TORQUE

## Electromagnetic tooth clutch - Type 543

### Characteristics and features

- high torque transfer despite compact dimensions
- positive-locking transmission of torque without slip
- engageable also at low relative speed
- high range of temperatures
- easy control via direct current
- anti-magnetic toothing for optimized magnetic flux
- current supply via plug and socket
- application-related customized tooth geometries
- short cycle times
- oil or dry running
- synchronized switching with fixed engagement positions
- uncompromizing need for safety and reliability
- integrated, easy-to-assemble system solution
- condition monitoring on demand



Mönninghoff power transmission represents an infinite variant diversity that is applied by all areas of modern mechanical engineering.

Our technologies are mostly designed to operate under extreme conditions. We offer high precision products for medical robotics, fail-proof security for aerospace technology or synchronization solutions for the packaging or printing industry.

We thus address customers who have the highest standards for their own machines or systems. To them, we can offer highly complex, application-specific solutions.

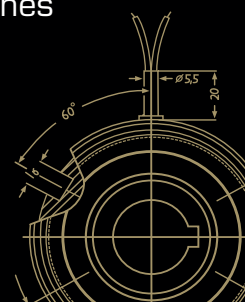

## Electromagnetic tooth clutch - Type 543

### Match code

Mönninghoff tooth clutches are indicated by the following match code:

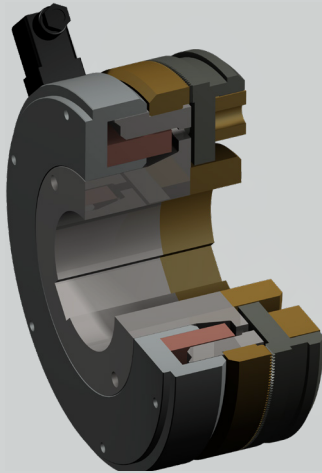

**543 . A . 2 . 4**

**A** clutch size

Other individual characteristics:

- tothing geometries
- voltage
- bore size with keyway

According to these characteristics, we design individual solutions concerning transmitted torque, engaging behavior or rotation speed.

Our engineers can assist with finding an application-specific clutch at any time. Together, we can develop individual and innovative solutions for extreme operating conditions.

### Ordering example

Mönninghoff tooth clutch  
Type 543.36.2.4

Tothing	standard
Voltage	24 Vdc
Bore size d	130 mm H7, keyway acc. to DIN 6885/1

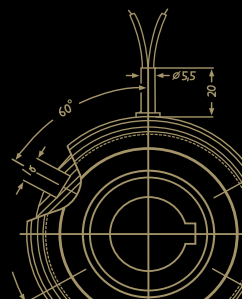

## Electromagnetic tooth clutch - Type 543

### Clutch size

When dimensioning a Mönninghoff tooth clutch, several technical preconditions should be considered:

- for the selection of the correct size, not only the peak load but also the dynamic behavior of the drive have to be taken into account
- tooth clutches - contrary to friction clutches - must never be overloaded and safety factors must be considered
- generally, the selection of the correct clutch is based on torque:

$$M = 9550 \frac{P}{n} \cdot K \text{ [Nm]}$$

$$M = (M_L + M_B) \cdot K \text{ [Nm]}$$

- the transmittable torque of the clutch must always be higher than the largest possible occurring torque:

$$\text{Requirement } M_{\ddot{U}} > M$$

- $P$  = power of motor [kW]  
 $n$  = rotating speed [ $\text{min}^{-1}$ ]  
 $K$  = safety factor 1,5 ... 2,5  
 $M$  = required torque  
 $M_L$  = load torque  
 $M_B$  = acceleration torque  
 $M_{\ddot{U}}$  = nominal torque of clutch (see enclosed chart)

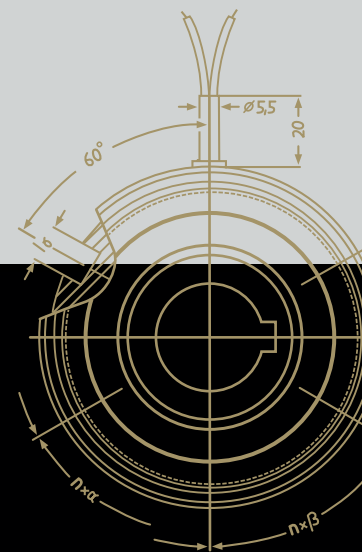

## Electromagnetic tooth clutch - Type 543

### Clutch size

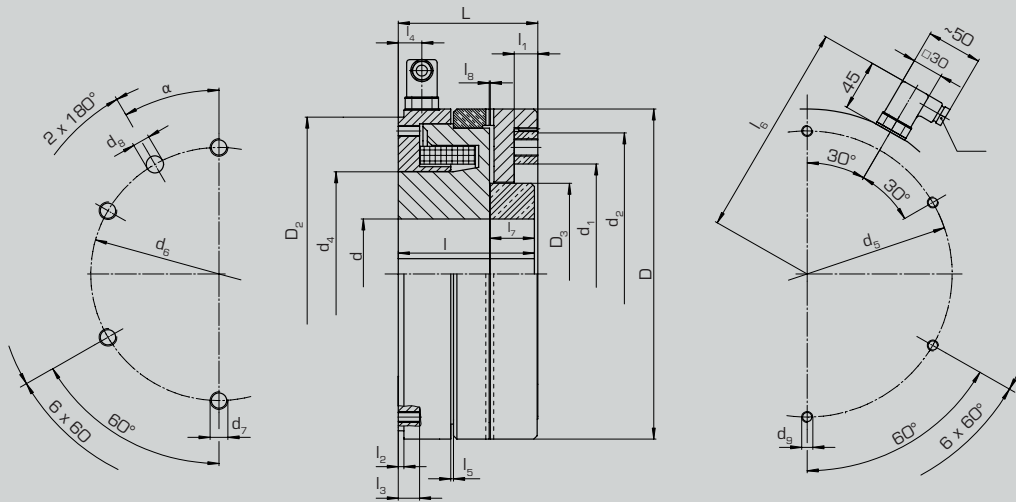

Tooth clutch with plug and socket

### Technical data

Size		33	36	41
torque	[Nm]	3200	6000	10000
max. speed	[min <sup>-1</sup> ]	2400	2000	1600
input power	[W]	83,5	176	288
inertia	rotor	102	258	593
	armature	86	199	598
weight	[kg]	33	55	102
number of teeth	standard	190	190	144
	saw	72	-	-
bore	keyway acc. to DIN 6885/1	60 - 110	75 - 135	80 - 140
	keyway acc. to DIN 6885/2	-	140	-
dimensions	D	250	300	360
	D <sub>2</sub> <sup>H8</sup>	235	285	340
	D <sub>3</sub>	130	165	168
	d <sub>1</sub> <sup>H7</sup>	160	200	230
	d <sub>2</sub>	219	259	309
	d <sub>3</sub>	147	186	210
	d <sub>5</sub>	220	260	310
	d <sub>6</sub>	190	230	270
	d <sub>7</sub>	M16	M16	M20
	d <sub>8</sub> predrilled	12,5	15,5	19,5
	d <sub>9</sub>	M8	M10	M12
	L	110	125	160
	l	107	122	156
	l <sub>1</sub>	21	21	30
	l <sub>2</sub>	5	5	6
	l <sub>3</sub>	15	19	28
l <sub>4</sub>	13	21	28	
l <sub>5</sub> ±0,5	1,7	2	3	
l <sub>6</sub>	-	195	225	
l <sub>7</sub>	35	40	56	
l <sub>8</sub> ±0,1	0,8	1	1	
α	[°]	30	30	40

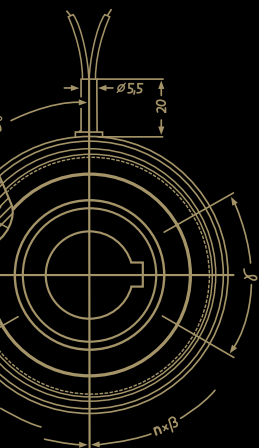

## Electromagnetic tooth clutch - Type 543

### Toothing geometries

Mönninghoff clutches offer a large variety of application-specific designs of toothing.

The amount of possible geometries or fixed points is endless and our engineers can help to design an optimized version at any time.

### Toothing examples

	<p><b>Standard</b></p> <ul style="list-style-type: none"><li>• transmits torque in both directions with little backlash</li><li>• also available backlash free</li><li>• with increased flank angle also available as torque limiter with fixed position engagement</li></ul>		<p><b>Spaced</b></p> <ul style="list-style-type: none"><li>• transmits torque in both directions with large amount of backlash</li><li>• can be engaged at higher speeds</li></ul>
	<p><b>Saw (counter-) clockwise</b></p> <ul style="list-style-type: none"><li>• transmits nominal torque in both directions</li><li>• in reverse direction approx. 10% of torque can be transmitted</li><li>• can be engaged at higher speeds</li></ul>		<p><b>Stepped (counter-) clockwise</b></p> <ul style="list-style-type: none"><li>• transmits nominal torque in both directions</li><li>• in reverse direction approx. 20% of torque can be transmitted with little backlash</li><li>• can be engaged at higher speeds</li></ul>

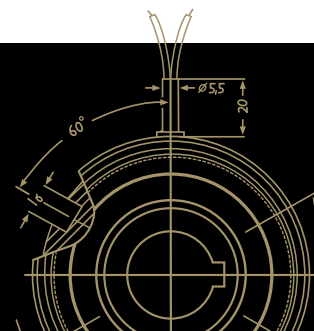

## Electromagnetic tooth clutch - Type 543

### Voltage

- standard voltage is 24 Vdc
- special voltages between 6 and 196 Vdc on request
- normally off clutch
- the permissible voltage tolerance is -10% to +5% according to VDE 0580
- in order to avoid induced voltage peaks, it is advisable to use varistors at unusually high switching frequency

### At a glance

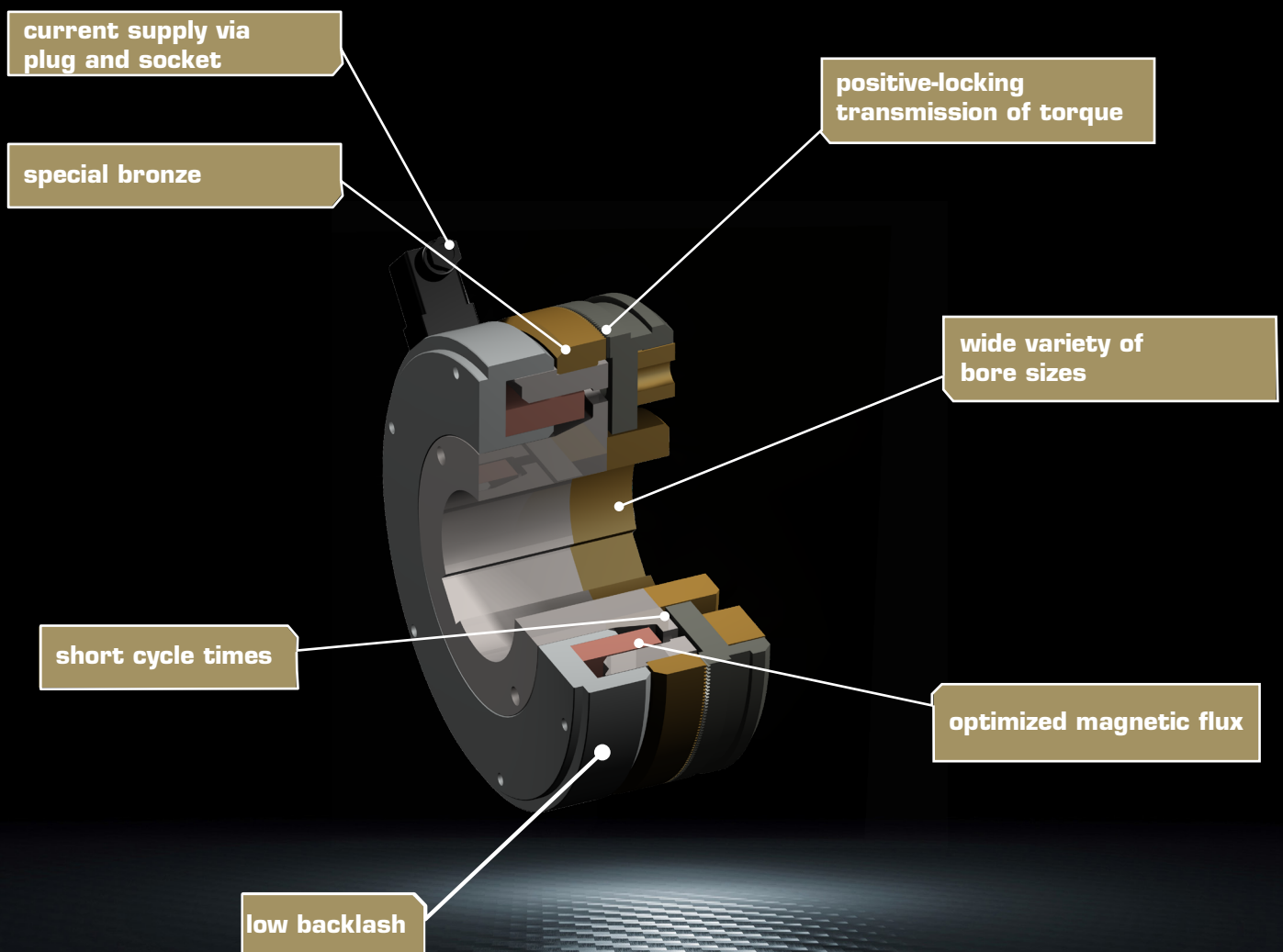

## System solutions

### You need more?

Mönninghoff clutches can be combined with a variety of many other power transmission elements. Such complex high-tech systems can solve any application-specific tasks and can fulfill any customer-specific wishes.

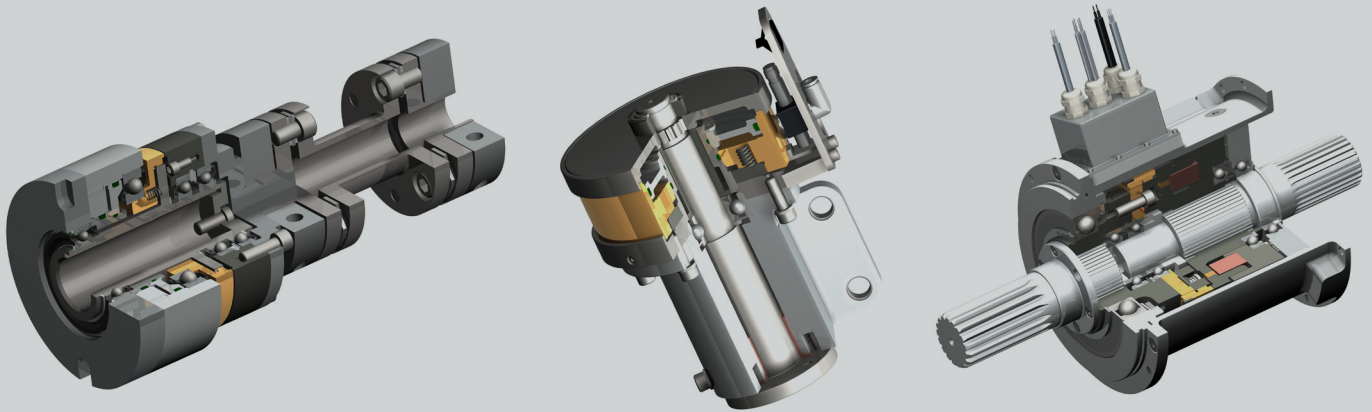

In many cases, a combination of different drive elements is needed to solve the applications particular problems and difficulties. Being not just supplier but technological partner to our customers, our extensive engineering is part of extraordinary and challenging power transmission projects.

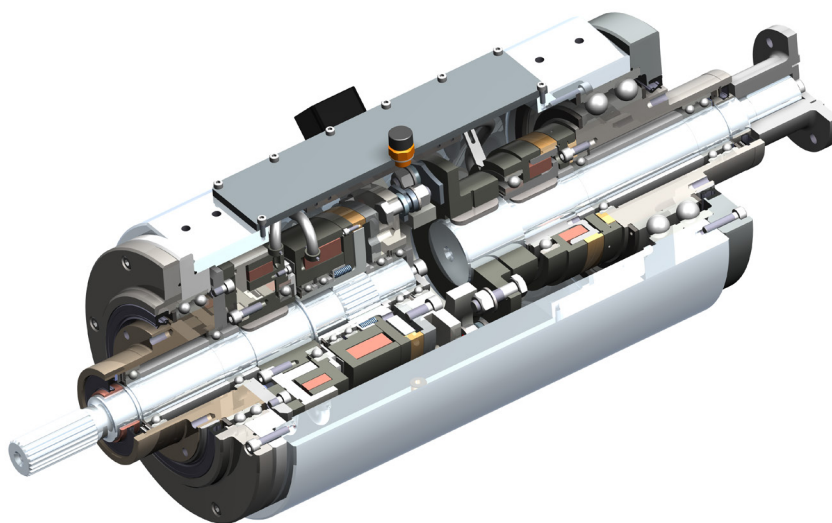

**Our product is the know-how,  
with hardware as an added bonus.**

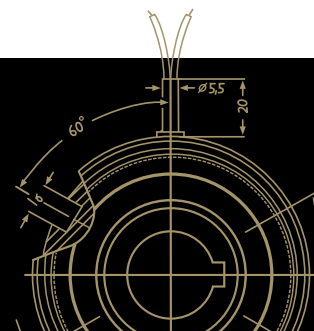



## Driven by excellence

### Why Mönninghoff

- intensive dialog with our customers' engineers
- decades of experience and competence
- deep understanding for all areas of mechanical engineering
- highly modern and flexible machine park
- enthusiasm for quality
- flexibility, inventiveness and communication skills of our employees
- commitment to Germany and Bochum as industrial location



Helps you find a customer-specific power transmission solution for extraordinary circumstances.



For the competent processing and smooth handling of your orders and delivery dates.



Feels committed to protect and preserve the high value of your machine and to secure its availability.



#### WA LOCATIONS

Unit 1 / 45 Inspiration Drive, Wangara WA 6065  
(08) 9303 4966

Unit 16 / 51-53 Kewdale Road, Welshpool WA 6106  
(08) 6314 1155

[support@chainanddrives.com.au](mailto:support@chainanddrives.com.au)

#### NSW LOCATION

Unit 7 / 70 Holbeche Road, Arndell Park NSW 2148  
(02) 9674 8611

[salesnsw@chainanddrives.com.au](mailto:salesnsw@chainanddrives.com.au)



A Mechanical Equipment Group Company