

Mönninghoff

Electromagnetic multiple-disc clutch Type 502

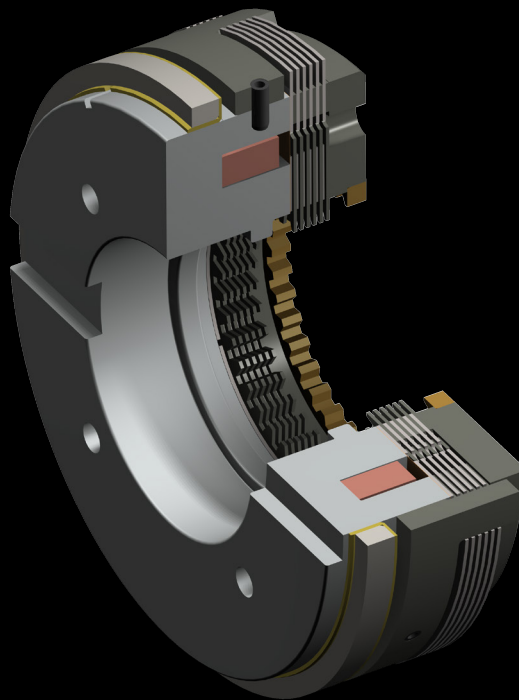

CHAIN & DRIVES
COMPLETE BEARINGS
& POWER TRANSMISSION

POWER > SPEED > TORQUE

Electromagnetic multiple-disc clutch - Type 502

Characteristics and features

- suitable for torque transmission with increasing differential speed between the drive elements
- high torque transfer despite compact dimensions
- designs up to 1600 Nm possible
- particularly suitable for shifting operations with a high energy exchange
- negligible wear due to special friction lining
- only oil running
- maintenance free
- suitable for applications in harsh environments
- reduced shift speeds due to adapted control
- also available as electromagnetic multiple-disc brake



Mönninghoff power transmission represents an infinite variant diversity that is applied by all areas of modern mechanical engineering.

Our technologies are mostly designed to operate under extreme conditions. We offer high precision products for medical robotics, fail-proof security for aerospace technology or synchronization solutions for the packaging or printing industry.

We thus address customers who have the highest standards for their own machines or systems. To them, we can offer highly complex, application-specific solutions.

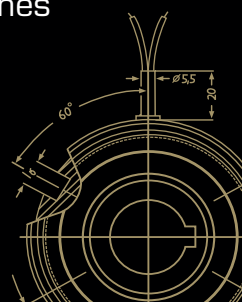

Electromagnetic multiple-disc clutch - Type 502

Match code

Mönninghoff multiple-disc clutches are indicated by the following match code:

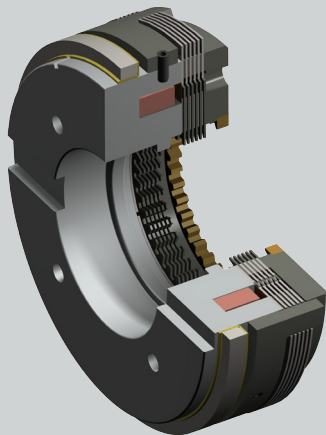

502 . A . B

A clutch size

B design

Other individual characteristics:

- voltage
- bore size with keyway

According to these characteristics, we design individual solutions concerning transmitted torque, engaging behavior or rotation speed.

Our engineers can assist with finding an application-specific clutch at any time. Together, we can develop individual and innovative solutions for extreme operating conditions.

Ordering example

Mönninghoff electromagnetic multiple-disc clutch
Type 502.21.1.1

Operating mode	dry running
Voltage	24 Vdc
Bore size d	30 mm H7, keyway acc to. DIN 6885/1

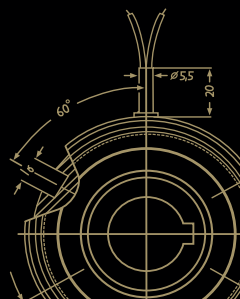

Electromagnetic multiple-disc clutch - Type 502

Clutch size

The selection of the correct size of a Mönninghoff electromagnetic multiple-disc clutch is determined by the required torque as well as the shift work.

- According to the required torque

$$M_s \geq M_{\text{erf}}$$

- According to the shift work

$$E_h \leq Q_h$$

The clutch must transfer load and acceleration torque (M_L ; M_b). The required safety is obtained by using a corresponding safety factor (K).

$$M_{\text{erf}} = (M_b \pm M_L) \cdot K$$

$$M_b = \frac{I \cdot \Delta n}{9,55 \cdot t} \quad [\text{Nm}]$$

$$Q_h = Q \cdot k_1 \cdot k_2 \quad [\text{Nm}]$$

$$E_h = \frac{I \cdot (\Delta n)^2 \cdot Z}{182,4} \quad [\text{Nm}]$$

If the load and acceleration torque cannot be determined, the required torque can be derived from the driving power, taking the required safety into consideration.

$$M_{\text{erf}} = 9550 \cdot \frac{P}{n} \cdot K \quad [\text{Nm}]$$

M_{erf}	= required torque
M_b	= acceleration torque
M_s	= shift torque
M_L	= output load torque
n	= speed of rotations [min^{-1}]
Δn	= differential speed of rotations [min^{-1}]
k_1	= correction factor
k_2	= correction factor

P	= driving power [kW]
K	= safety factor [1,2 to 4]
I	= moment of inertia [kgm^2]
Z	= number of shift operations per hour
Q	= amount of heat
E_h	= shift energy per hour [Nm]
t	= acceleration time [sec] based on t_1

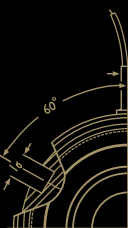

Electromagnetic multiple-disc clutch - Type 502

Determination of shift work

The energy that is lost in the clutch depends on the shift curve and the shift frequency. The correction factors for the permissible shift work per hour Q_n can be derived from the tables and graphs.

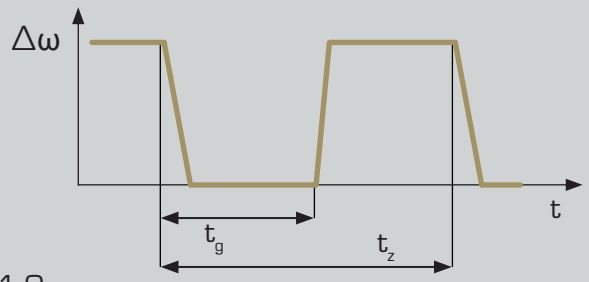

Course of a shift cycle
 t_g = time during which the clutch is closed
 t_z = total cycle time
 $\Delta\omega$ = differential angular velocity

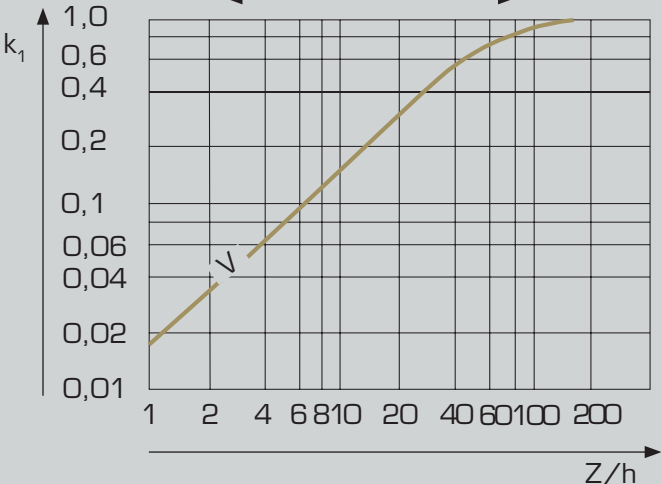

Correction factor k_1 as a function of the shift frequency per hour
 V valid for all sizes and types of clutches whose discs are surrounded by the field of force

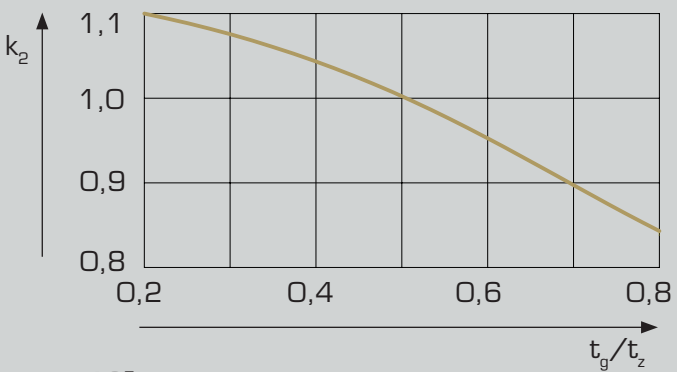

Correction factor k_2 as function t_g/t_z

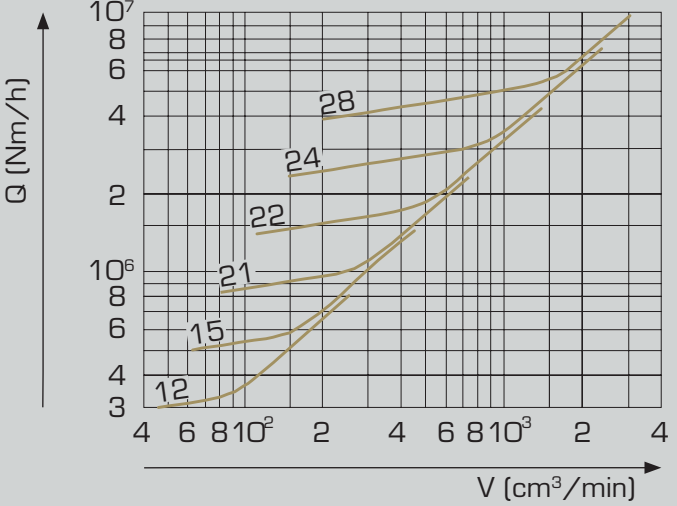

Amount of heat Q as function of the amount of cooling oil; valid for clutches whose discs are surrounded by the field of force

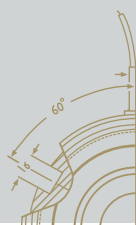

Electromagnetic multiple-disc clutch - Type 502

Switching

Electromagnetic clutches are inductances. Engagement and disengagement are subject to the laws of induction, i. e. the induction current increases according to an e-function.

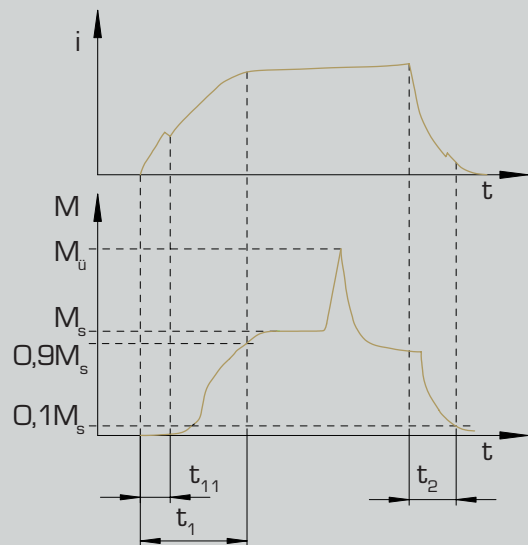

Shift speeds

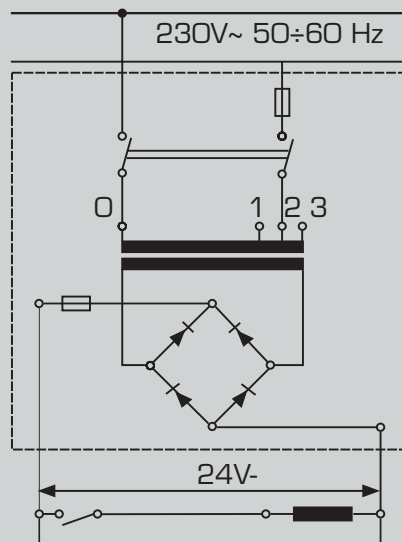

Shift diagram: normal shifting

- t_1 and t_2 can be electrically influenced by taking appropriate measures
- it is advisable to use direct current for shifting
- when determining the size, the engage time is considered to be approximately 30% of the total acceleration time, which normally results in additional safety

Technical data

Size	16	21	22	24	26	28	normal excitation (fast excitation 3 times)
shift speeds acc. to VDE 0580:2011-11							
t_1 [msec]	220/140	250/160	360/250	450/330	600/450	900/600	
t_2	70/60	90/80	110/100	200/180	250/220	400/350s	

i = induction current

M_u = torque to be transferred / static torque

M_s = torque to be shifted

t_1 = engage time

t_2 = disengage time

t_{11} = response delay



Electromagnetic multiple-disc clutch - Type 502

Clutch size

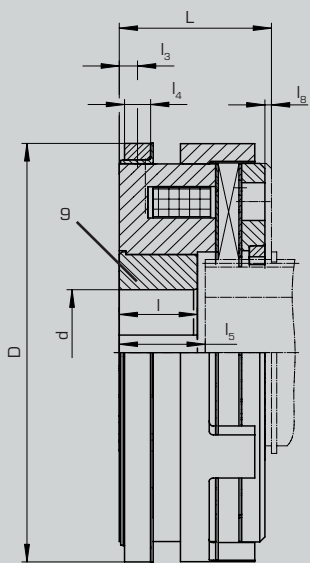

Type 1: with hub

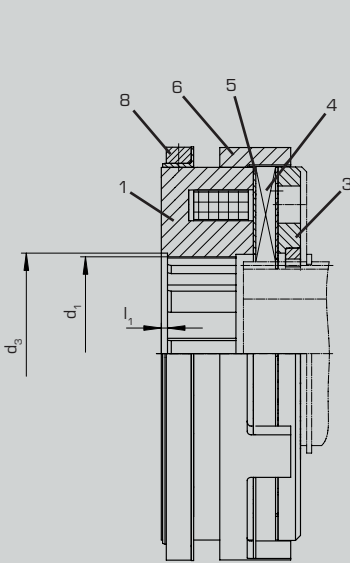

Type 1: without hub

- 1 Coilbody
- 3 Armature
- 4 Inner plate
- 5 Outer plate
- 6 Drive ring
- 8 Slip ring
- 9 Hub

120

Technical data

Size		12	15	21	22	24	28	
torque	M_s dyn [Nm]	25	60	120	250	480	960	
max. speed	[min ⁻¹]	3000	3000	2400	2000	2000	2000	
input power	[W]	18	30	30	45	66	88	
inertia	parts 1, 5, 6, 8, 9	1,1	3,0	6,8	16,8	39	93	
	parts 3, 4	0,18	0,5	1,45	4,8	11	34	
weight	[kg]	1,25	2,25	4	6,4	10,5	18	
number of plates	inner plate	4	5	5	5	6	6	
	outer plate	4	5	5	5	6	6	
min. bore	keyway acc. to DIN 6885/1 d H7	15	20	25	30	35	50	
max. bore		25	32	38	52	62	75	
number of keyways in the hub		1	1	2 x 180	2 x 180	4 x 90	4 x 90	
multikeyway	DIN 5462	d_1	8 x 36	8 x 46	8 x 52	10 x 72	10 x 82	10 x 102
			8 x 40	8 x 50	8 x 58	10 x 78	10 x 88	10 x 108
dimensions	D	[mm]	95	114	134	166	195	240
	d_1 H7		36	46	52	72	82	102
	d_3 H9		42	52	60	80	90	110
	L		36	45,5	52	58,5	68,5	77
	l-0,1		20	23	26	30	33,5	37
	l_1		1,5	2	2	2,5	3	3
	l_3		5,5	6	7	7	7	8,5
	l_4		8	8	10	10	10	10
	l_5		23	26	29	33	36,5	40
	l_6		1,2	1,8	2	2,5	3,5	5

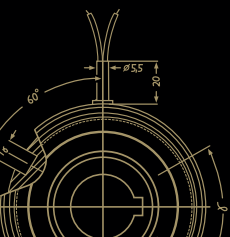

Electromagnetic multiple-disc clutch - Type 502

Clutch size

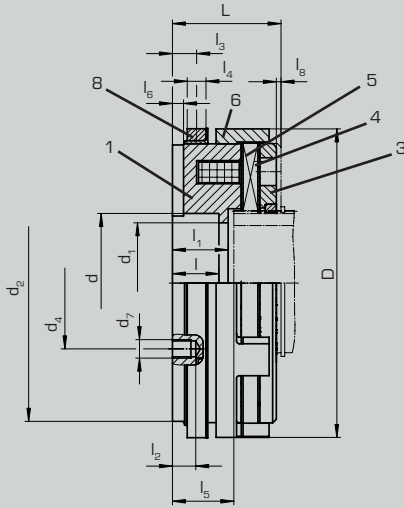

- 1 Coilbody
- 3 Armature
- 4 Inner plate
- 5 Outer plate
- 6 Drive ring
- 8 Slipring

Type 3

Technical data

Size		12	15	21	22	24	28
torque	$M_{e,dyn}$ [Nm]	25	60	120	250	480	960
max. speed	[min ⁻¹]	3000	3000	2400	2000	2000	2000
input power	[W]	18	30	30	45	66	88
inertia	parts 1, 5, 6, 8	1,5	3,7	7,23	19,3	40	95
	parts 3, 4	0,18	0,5	1,45	4,8	11	34
weight	[kg]	1,2	2	3,5	6,5	9,3	16,7
number of plates	inner plate	4	5	5	5	6	6
	outer plate	4	5	5	5	6	6
dimensions	D [mm]	95	114	134	166	195	240
	d K6	42	55	68	75	90	110
	d ₁	37	45	60	65	80	100
	d ₂	85,5	95	120	150	178	218
	d ₄	56	75	90	100	116	145
	d ₇	M6	M8	M8	M10	M10	M12
	L	38	49,5	55	58,5	69	80
	l ₃ +0,2	20	22	22	25	28	32
	l ₁	22	27	29	30	34	40
	l ₂	5	8	8	10	12	18
	l ₃	7,5	11	11	13	13	14,5
l ₄	8	8	10	10	10	10	
l ₅	25	30	32	33	37	43	
l ₆ +0,1	2,5	5	5	6	6	6	
l ₇ H7	12	14	16	20	20	25	
l ₈	1,2	1,8	2	2,5	3,5	5	

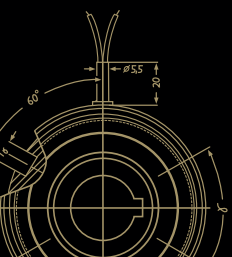

Electromagnetic multiple-disc clutch - Type 502

Clutch size

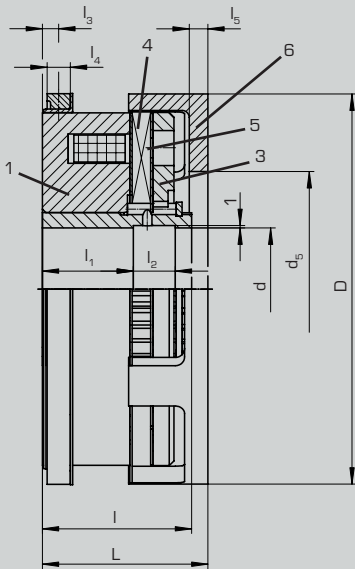

- 1 Coilbody
- 3 Armature
- 4 Inner plate
- 5 Outer plate
- 6 Drive ring

Type 4

120

Technical data

Size		12	15	21	22	24	28
torque	M_{s_dyn} [Nm]	25	60	120	250	480	960
	M_{s_stat}	40	100	200	400	800	1600
max. speed	[min ⁻¹]	3000	3000	2400	2000	2000	2000
input power	[W]	18	30	30	45	66	88
inertia	parts 1, 3, 4 [10 ⁻³ kgm ²]	1,2	3,2	7,4	20,5	48	117
	parts 5, 6	0,5	1,6	3	7	14,5	50
weight	[kg]	1,5	2,6	4,5	7,8	13,7	26,5
number of plates	inner plates	5	6	6	6	7	7
	outer plates	4	5	5	5	6	6
min. bore	keyway acc. to DIN 6885/1 d H7 [mm]	15	20	25	30	35	50
max. bore		25	32	40	50	60	75
dimensions	D [mm]	95	114	134	166	195	240
	d_5 H7	45	51	61	75	90	112
	L	46	55	61,5	71	85	90
	$l - 0,1$	41	49	56	64	76	80
	l_1	31	29	32	39	43	42
	l_2	10	14	14	18	20	20
	l_3	6	6	7	7	7	8,5
	l_4	8	8	10	10	10	10
l_5	5	6	6	8	9	10	

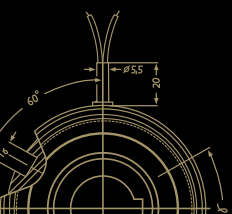

Electromagnetic multiple-disc clutch - Type 502

Inner driver

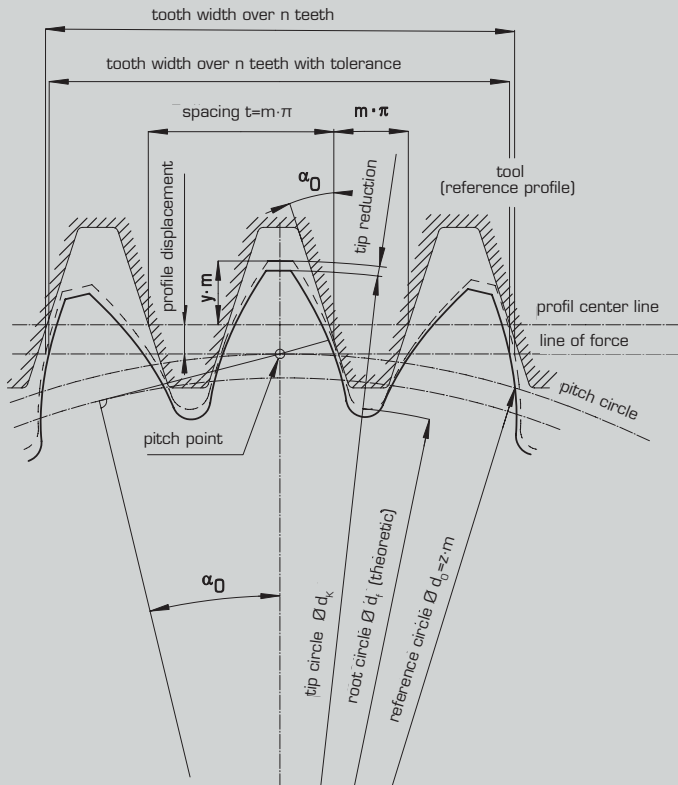

Gear specifications acc. to DIN 867

Index 1: design 1, 2 and 4 possess 28 teeth

Index 2: design 3 possesses 31 teeth

- the surface hardness of the driver is 59 - 62 HRC
- case depth can vary from 0,2 to 0,6 mm

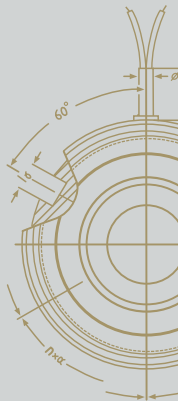

z = number of teeth

m = module

d_0 = reference diameter (= $z \cdot m$)

d_k = outside diameter

d_f = root diameter

α_0 = pressure angle (= 20°)

Technical data

Size		12	15	21	21	22	24	28
index				1	2			
number of teeth	z	27	27	28	31	27	33	42
module	m	1,5	1,75	2	2	2,5	2,5	2,5
outside diameter	$d_{k,0,2}$ [mm]	43,3	50,5	60,5	66,4	73,2	88,2	110,0
root diameter	d_f [mm]	37,65	43,96	52,64	58,68	63,40	78,40	98,15
tooth width	$Wn_{0,05}$ [mm]	16,37	19,11	22,01	22,10	27,51	27,72	34,48
number of measuring teeth over "n" teeth		4	4	4	4	4	4	5
profile displacement	x [mm]	+0,3	+0,31	+0,41	+0,42	+0,43	+0,43	-0,12
tooth length	l_{zmin} [mm]	12	18,5	21,5	21,5	23,5	30	33,0

Electromagnetic multiple-disc clutch - Type 502

Voltage

- standard voltage is 24 Vdc direct current
- special voltages as an example 48 Vdc on request

Technical characteristic

- must run in oil
- the arrangement of the discs between the pole faces and the armature requires the discs to be made of a ferromagnetic material with good friction and wear properties, which are obtained by hardening and nitriding
- residual magnetism resulting from the hardening process is eliminated by the special design of the discs
- the shape of the discs prevents the oil from building up when the temperature drops, thus avoiding shift delays
- clutches whose discs are surrounded by the field of force are particularly suitable for shifting operations with a high energy exchange
- require no maintenance

At a glance

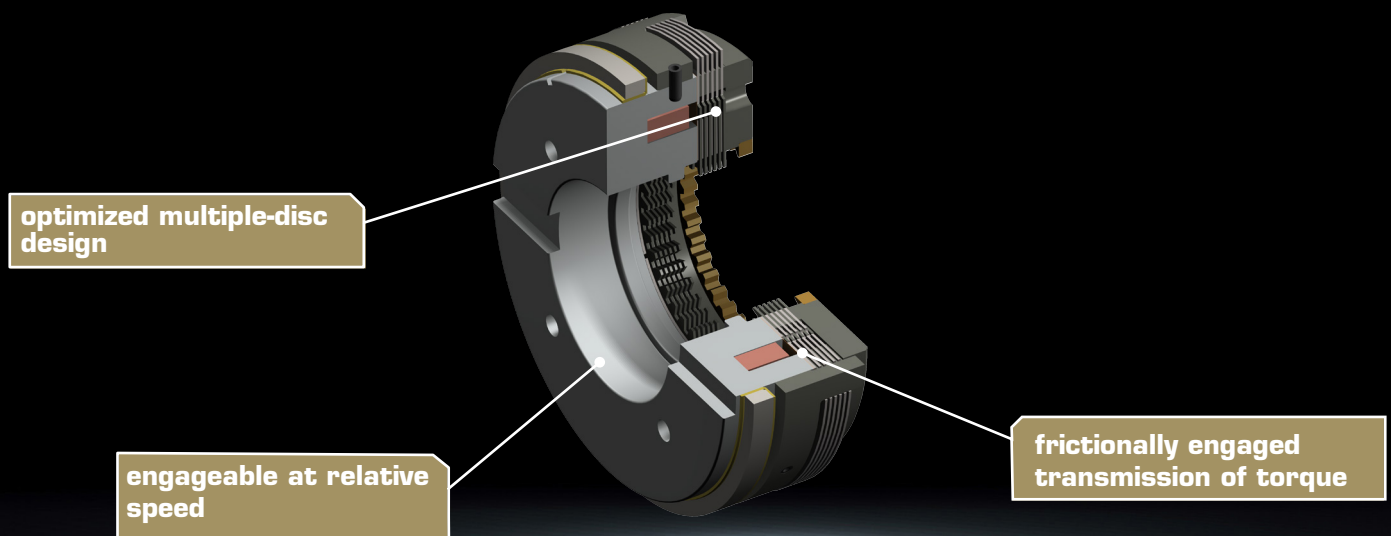

System solutions

You need more?

Mönninghoff clutches can be combined with a variety of many other power transmission elements. Such complex high-tech systems can solve any application-specific tasks and can fulfill any customer-specific wishes.

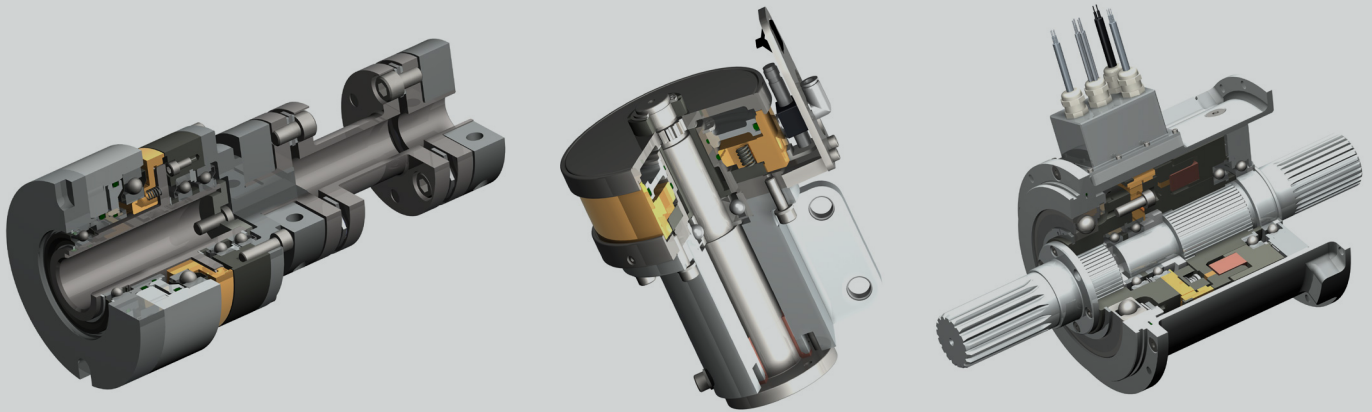

In many cases, a combination of different drive elements is needed to solve the applications particular problems and difficulties. Being not just supplier but technological partner to our customers, our extensive engineering is part of extraordinary and challenging power transmission projects.

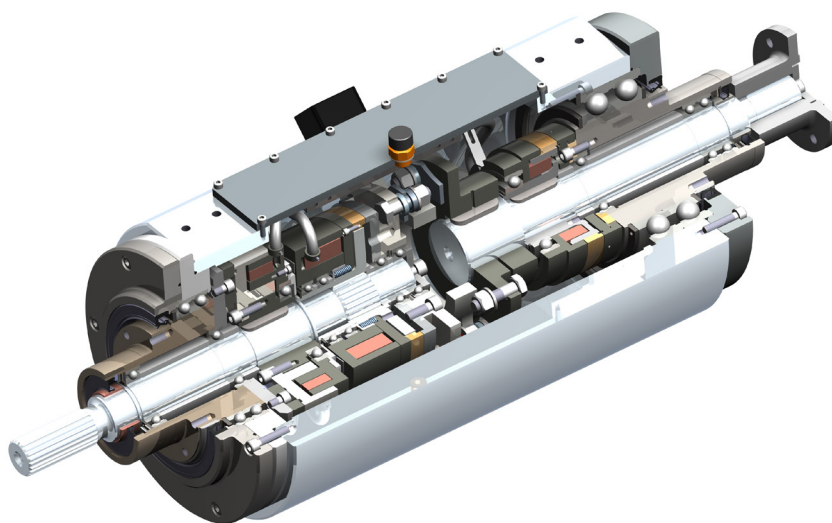

**Our product is the know-how,
with hardware as an added bonus.**

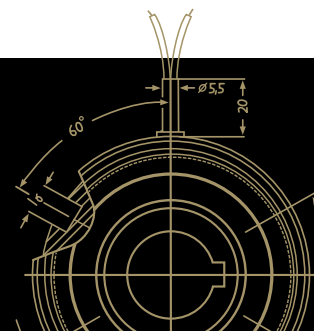

Driven by excellence

Why Mönninghoff

- intensive dialog with our customers' engineers
- decades of experience and competence
- deep understanding for all areas of mechanical engineering
- highly modern and flexible machine park
- enthusiasm for quality
- flexibility, inventiveness and communication skills of our employees
- commitment to Germany and Bochum as industrial location



Helps you find a customer-specific power transmission solution for extraordinary circumstances.



For the competent processing and smooth handling of your orders and delivery dates.



Feels committed to protect and preserve the high value of your machine and to secure its availability.



WA LOCATIONS

Unit 1 / 45 Inspiration Drive, Wangara WA 6065
(08) 9303 4966

Unit 16 / 51-53 Kewdale Road, Welshpool WA 6106
(08) 6314 1155

support@chainanddrives.com.au

NSW LOCATION

Unit 7 / 70 Holbeche Road, Arndell Park NSW 2148
(02) 9674 8611

salesnsw@chainanddrives.com.au



A Mechanical Equipment Group Company