

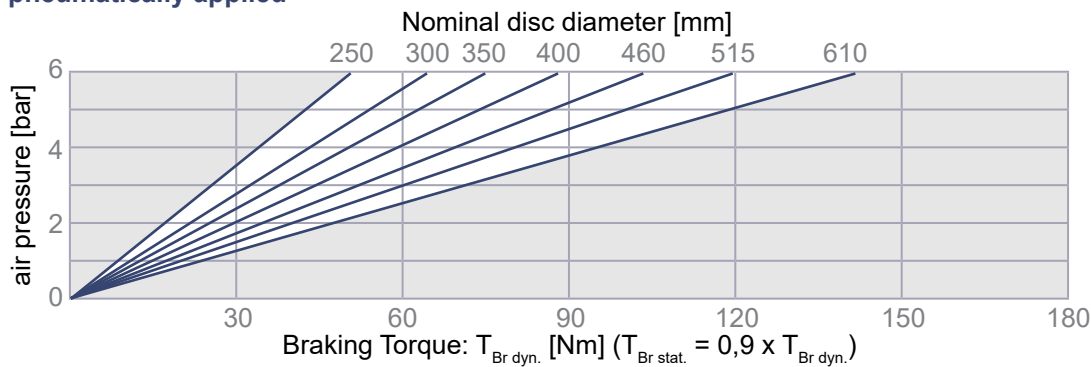

2D-drawing and dimensions see pg. 2

pneumatically applied



p_{max} : 8 bar

hydraulically applied

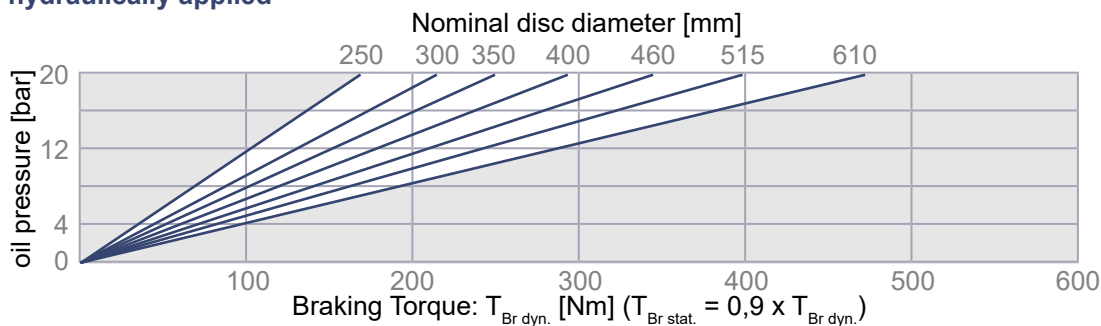

p_{max} : 20 bar

Subject to change without notice.

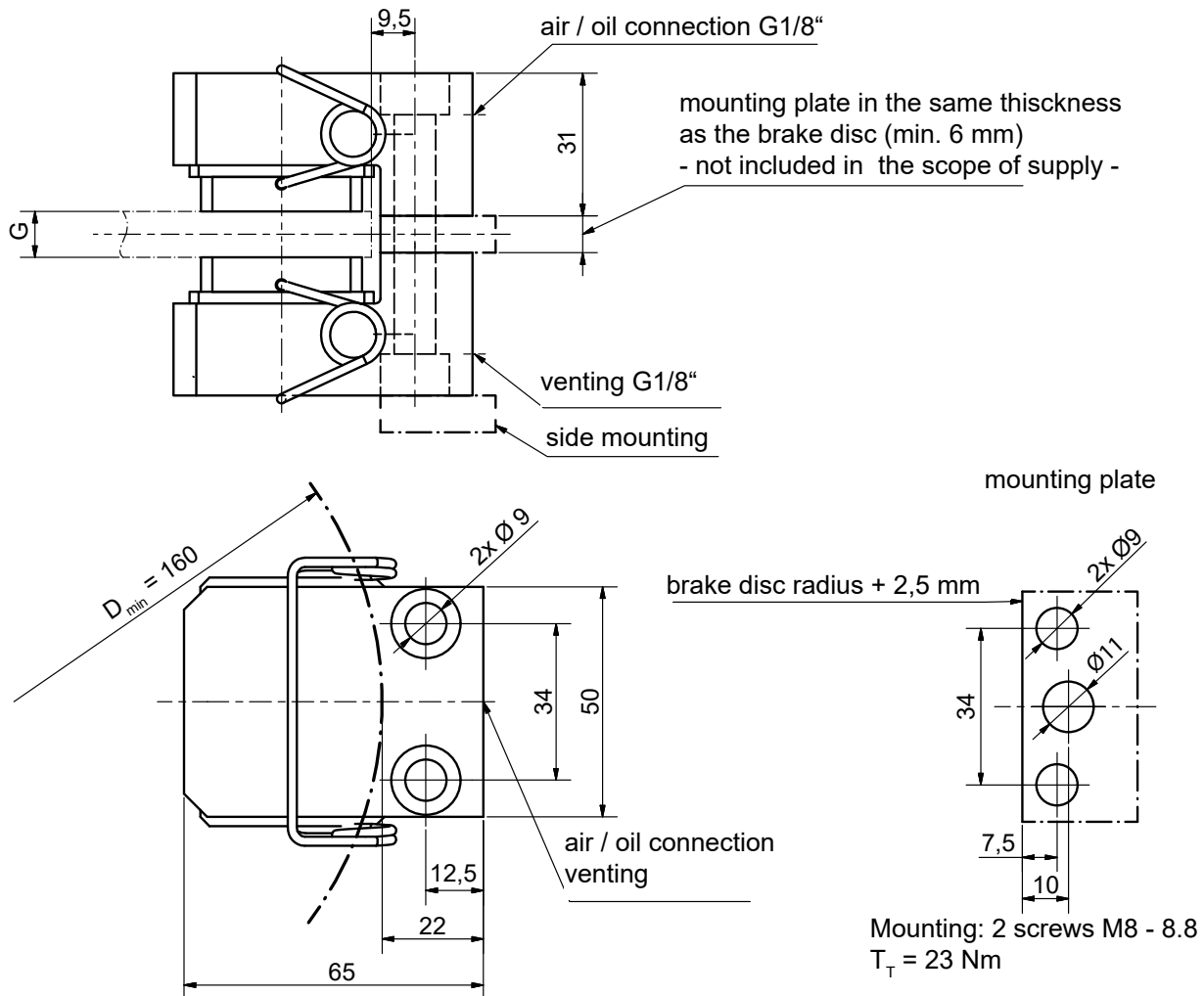

For G = 8 mm: EB 108, **Part-No. 12294**

For G = 15 mm: EB 115, **Part-No. 10811**

Further disc thicknesses and mounting plates for side mounting on request.

For use with mineral oil.

Subject to change without notice.

Elephant Brakes by Rietschoten Germany. Strong like an elephant. Smart like an elephant.

Deutsche van Rietschoten & Houwens GmbH · Junkersstraße 12 · 30179 Hannover · www.elephantbrakes.com