

An exploded view diagram of the INTORQ BFK455 brake assembly. The diagram shows the main circular brake disc with a central hub, several curved brake shoes, and various mounting hardware including bolts and nuts. The components are arranged in a perspective view, showing their relative positions and how they fit together.

INTORQ

setting the standard

INTORQ BFK455

Electromagnetically released spring-applied brake

Operating Instructions

This documentation applies to ...

BFK455-28 - double-disk version

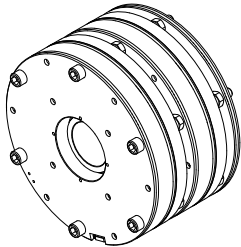

BFK455-001.iso/dms

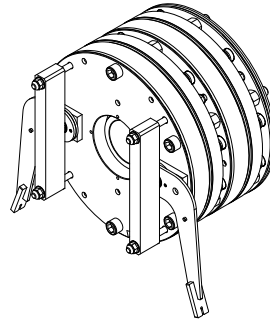

BFK455-020.iso/dms

Product key

Product key

INTORQ B FK □□□ - □□

A

B

C

D

Legend for the INTORQ BFK455 product key

A	Product group	Brakes
B	Product type	Spring-applied brake
C	Type	455
D	Size	28

Not coded: supply voltage, hub bore, options

Identification

Package label		Example	
Manufacturer	Bar code		
Type (see product key)	Type No.		
Name	Quantity per box		
Rated voltage	Rated torque		Packing date
Rated power	Hub diameter		
Additional information	CE designation		

BFK455-101.iso/dms

Nameplate		Example	
Manufacturer	CE designation		
Type (see product key)	Hub diameter		
Rated voltage	Rated power		Production date
Type No.	Rated torque		

BFK455-002.iso/dms

Notes

The brake is marked with the following labels, which have to be observed:

for holding voltage	for air gap setting
Lüftspannung: Release voltage: 205 V DC Haltespannung: Holding voltage: 103 V DC Nur mit BEG-561-255-030 betreiben! Only use with BEG-561-255-030! Nr./No.: 13346411	DE: Den nach der Erstinatallation eingestellten Luftspalt nicht verstellen! EN: Do not re-adjust air-gap after first installation! FR: Ne plus regler l'entrefer après la première installation!

Document history

Material number	Version	Description		
33000803	1.0	05/2011	TD09	First edition
33000803	1.1	05/2012	TD09	Change in telephone and fax number Front and back page new Addition of the EC type test number Supplemented by chapter "Project planning notes" Supplemented by chapter "Wear of spring-applied brakes"
33002468	2.0	03/2013	TD09	Amended by new chapter on hand-release installation Tables of dimensions and operating times were changed Amendment of the spare parts list and the spare parts order
33002468	3.0	05/2013	TD09	Limitation of the adjustability Note on the suppressor circuit added to the "Electrical installation" chapter Values for characteristic torque 2x2065 Nm added to "Dimensions" table

i Contents

1	Preface and general information	6
1.1	About these Operating Instructions	6
1.2	Terminology used	6
1.3	Conventions used	6
1.4	Abbreviations used	7
1.5	Notes used	8
1.6	Scope of supply	9
1.7	Disposal	9
1.8	Drive systems	9
1.9	Legal regulations	10
2	Safety instructions	11
2.1	General safety information	11
2.2	Application as directed	12
3	Technical data	13
3.1	Product description	13
3.2	Rated data	16
3.3	Rated data (selection data)	17
3.4	Friction work / operating frequency	19
3.5	Emission	20
4	Mechanical installation	21
4.1	Important notes	21
4.2	Necessary tools	21
4.3	Mounting	21
4.4	Installation	22
4.5	Manual release	28
4.6	Assembly of the cover ring	34
5	Electrical installation	35
5.1	Electrical connection	35
5.2	Bridge/half-wave rectifiers (option)	36
5.3	Electrical connection	38
6	Commissioning and operation	39
6.1	Important notes	39
6.2	Function checks before commissioning	39
6.3	Commissioning	40
6.4	During operation	41

i Contents



7	Maintenance/repair	42
	7.1 Wear of spring-applied brakes	42
	7.2 Inspections	43
	7.3 Maintenance operations	44
	7.4 Spare-parts list	46
	7.5 Spare parts order	47
8	Troubleshooting and fault elimination	48

1 Preface and general information

1.1 About these Operating Instructions

- These Operating Instructions will help you to work safely on and with the spring-applied brake with electromagnetic release. They contain safety instructions that must be followed.
- All persons working on or with the electromagnetically released spring-applied brakes must have the Operating Instructions available and observe the information and notes relevant for them.
- The Operating Instructions must always be in a complete and perfectly readable condition.

1.2 Terminology used

	Term	In the following text used for
	Spring-applied brake	Spring-applied brake with electromagnetic release
	Drive system	Drive systems with spring-applied brakes and other drive components

1.3 Conventions used

This documentation uses the following conventions to distinguish different types of information:

Spelling of numbers	Decimal separator	Point	The decimal point is always used. For example: 1234.56
	Symbols	Page reference	Reference to another page with additional information For example: □ 16 = see page 16
	Document reference	☺	Reference to another documentation with additional information For example: ☺ Operating instructions
	Wildcard	□	Wildcard for options, selections For example: BFK458-□□ = BFK458-10

1 Preface and general information

1.4 Abbreviations used

Abbreviation	Unit	Name
I	A	Current
I _H	A	Holding current at 20 °C and holding voltage
I _L	A	Release current at 20 °C and release voltage
I _N	A	Rated current at 20 °C and rated voltage
M _A	Nm	Tightening torque of the fixing screws
M _K	Nm	Rated torque of brake, rated value at a relative speed of 100 rpm
n _{max}	rpm	Maximum speed during the slipping time t ₃
P _H	W	Coil power during holding, through normal excitation and 20 °C
P _L	W	Coil power during release, through normal excitation and 20 °C
P _N	W	Rated coil power at rated voltage and 20 °C
Q	J	Heat/energy
Q _E	J	Max. permissible friction work per switching cycle, thermal rating of the brake
Q _R	J	Braking energy, friction work
Q _{Smax}	J	Max. permissible friction work during cyclic switching, depending on the operating frequency
R _N	Ohm	Rated coil resistance at 20 °C
S _h	1/h	Operating frequency, the number of repeated operations per unit time
S _{hue}	1/h	Transitional operating frequency, thermal rating of the brake
S _{hmax}	1/h	Maximum permissible operating frequency, depending on the friction work per operation
s _L	mm	Air gap, movement of armature plate by switching the brake
s _{LN}	mm	Rated air gap
s _{Lmin}	mm	Minimum air gap
s _{Lmax}	mm	Maximum air gap
t ₁	ms	Engagement time, the total of the reaction delay and torque rise time $t_1 = t_{11} + t_{12}$
t ₂	ms	Disengagement time, time from switching the stator until the torque has reduced to 0.1 M _K
t ₁₁	ms	Slipping time to standstill (after t ₁₁)
t ₁₁	ms	Delay time when connecting, time from disconnecting the voltage until the torque begins to rise
t ₁₂	ms	Rise time of braking torque, time from beginning of rise of torque until braking torque is reached
t _{ue}	S	Overexcitation time
U	V	Voltage
U _H	V DC	Holding voltage by change of voltage
U _L	V DC	Release voltage by change of voltage
U _N	V DC	Rated coil voltage for brakes which require automatic voltage changing, the rated coil voltage U _{rated} is the same as the release voltage U _L

1 Preface and general information

1.5 Notes used

The following pictographs and signal words are used in this documentation to indicate dangers and important information:

Safety instructions



Structure of safety instructions:

 **Danger!**
 Characterises the type and severity of danger



Note
 Describes the danger

Possible consequences:
 ■ List of possible consequences if the safety instructions are disregarded.

Protective measure:
 ■ List of protective measures to avoid the danger.

Pictograph and signal word	Meaning
 Danger!	Danger of personal injury through dangerous electrical voltage Reference to an imminent danger that may result in death or serious personal injury if the corresponding measures are not taken.
 Danger!	Danger of personal injury through a general source of danger Reference to an imminent danger that may result in death or serious personal injury if the corresponding measures are not taken.
 Stop!	Danger of property damage Reference to a possible danger that may result in property damage if the corresponding measures are not taken.

Application notes

Pictograph and signal word	Meaning
 Note!	Important note to ensure troublefree operation
 Tip!	Useful tip for simple handling
	Reference to another documentation

1 Preface and general information

1.6 Scope of supply

After receipt of the delivery, check immediately whether it corresponds to the accompanying papers. INTORQ does not grant any warranty for deficiencies claimed subsequently.

- Claim visible transport damage immediately to the forwarder.
- Claim visible deficiencies / incompleteness immediately to INTORQ GmbH & Co.KG.

1.7 Disposal

The spring-applied brake consists of different types of material.

- Recycle metals and plastics.
- Ensure professional disposal of assembled PCBs according to applicable environmental regulations.

1.8 Drive systems

Labelling

Drive systems and components are unambiguously designated by the indications on the nameplate.

Manufacturer: INTORQ GmbH & Co KG, Wülmser Weg 5, D-31855 Aerzen

- The spring-applied INTORQ brake is also delivered in single modules and individually combined to its modular design. The data - package labels, nameplate, and type code in particular - apply to one complete stator.
- If single modules are delivered, the labelling is missing.

1 Preface and general information

1.9 Legal regulations

Liability

- The information, data and notes in this documentation met the state of the art at the time of printing. Claims referring to products which have already been supplied cannot be derived from the information, illustrations and descriptions.
- We do not accept any liability for damage and operating interference caused by:
 - inappropriate use
 - unauthorised modifications to the product
 - improper working on and with the product
 - operating faults
 - disregarding the documentation

Warranty

- Terms of warranty: see terms of sale and delivery of INTORQ GmbH & Co. KG.
- Warranty claims must be made to INTORQ immediately after detecting defects or faults.
- The warranty is void in all cases where liability claims cannot be made.

2 Safety instructions

2.1 General safety information

- INTORQ components ...
 - ... must only be applied as directed.
 - ... must not be commissioned if they are noticeably damaged.
 - ... must not be technically modified.
 - ... must not be commissioned if they are mounted and connected incompletely.
 - ... must not be operated without the required covers.
 - ... can hold live as well as moving or rotary parts during operation according to their degree of protection. Surfaces may be hot.
- For INTORQ components ...
 - ... the documentation must always be kept at the installation site.
 - ... only permitted accessories are allowed to be used.
 - ... only original spare parts of the manufacturer are allowed to be used.
- All specifications of the corresponding enclosed documentation must be observed.
This is vital for a safe and trouble-free operation and for achieving the specified product features.
- Only qualified, skilled personnel are permitted to work on and with INTORQ components.
In accordance with IEC 60364 or CENELEC HD 384, qualified, skilled personnel are persons ...
 - ... who are familiar with the installation, mounting, commissioning, and operation of the product.
 - ... who have the qualifications necessary for their occupation.
 - ... who know and apply all regulations for the prevention of accidents, directives, and laws relevant on site.
- Risk of burns!
 - Surfaces may be hot during operation! Provide for protection against accidental contact.
- Risk of injury due to a rotating shaft!
 - Wait until the motor is at standstill before you start working on the motor.
- The friction lining and the friction surfaces must by no means have contact to oil or grease since even small amounts reduce the brake torque considerably.
- The brake is designed for operation under the environmental conditions that apply to IP54. Because of the numerous possibilities of using the brake, it is however necessary to check the functionality of all mechanical components under the corresponding operating conditions.

2 Safety instructions

2.2 Application as directed

- INTORQ components ...
 - ... are intended for use in machinery and systems.
 - ... must only be used for the purposes ordered and confirmed.
 - ... must only be operated under the ambient conditions prescribed in these Operating Instructions.
 - ... must not be operated beyond their corresponding power limits.

Any other use shall be deemed inappropriate!

Possible applications of the INTORQ spring-applied brake

- Humidity: no restrictions
 - In case of formation of condensed water and moisture: provide for appropriate ventilation to ensure that all components will dry quickly.
- Ambient temperature:
 - 5 °C to +40 °C
- At high humidity and low temperature:
 - Take measures to protect armature plate and rotor from freezing.
- Protect electrical connections against contact.

3 Technical data

3.1 Product description

Versions

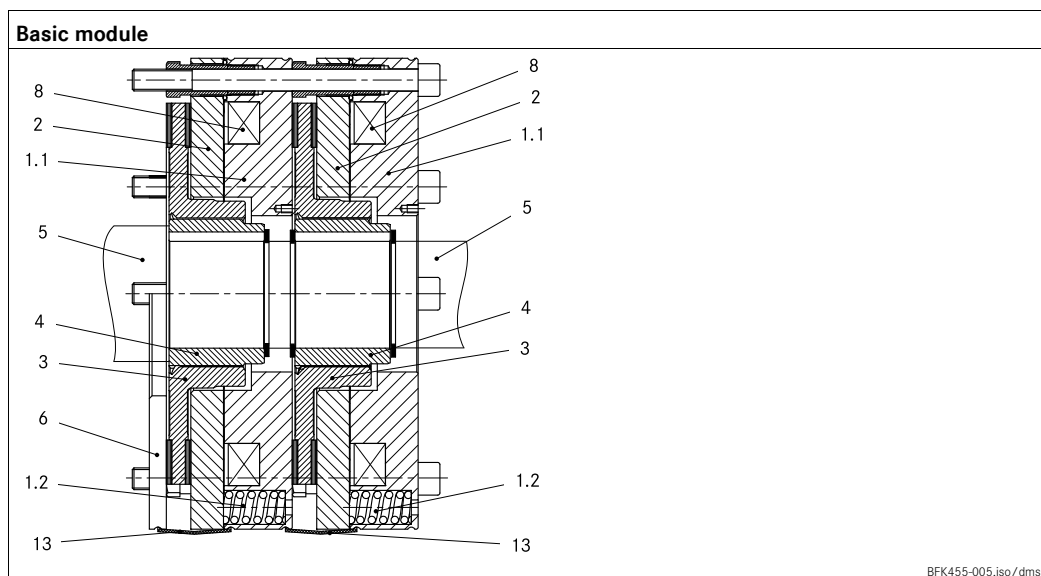

Fig. 1 Design of a BFK455 spring-applied brake

1.1	Stator	3	Complete rotor	6	Flange
1.2	Compression springs	4	Hub	8	Coil
2	Armature plate	5	Shaft	13	Cover ring

3.1.1 General information

The spring-applied brake is designed for the conversion of mechanical work and kinetic energy into heat. Due to the static brake torque, the brake can hold loads without speed difference. Emergency braking is possible at high speed. The more friction work, the higher the wear, (operating speeds 16).

The BFK455 spring-applied brake is a double disc brake with four friction surfaces. The braking torque is generated within two electrically and mechanically separated braking circuits by means of several compression springs (1.2) with friction locking. The braking circuits are released electromagnetically. Due to its division into two braking circuits, the brake is especially suitable for applications in the fields of lift technology and stage machinery. The brake is selected on the basis of the characteristic torque for one braking circuit. The second braking circuit meets the requirement for redundancy.

The braking circuits are divided by two separate armature plates (2) with the respective compression springs (1.2) assigned and electromagnetic coils (8). The separate connecting cables for each stator and armature plate render it possible to switch each braking circuit individually, 36.

3 Technical data

The switching status of the spring-applied brake is monitored by one microswitch (16) for each braking circuit. The associated switchgear rectifies the supply voltage (AC voltage) which is reduced after a short time while the brake is in the released state. Thus the mean electrical power of the brake is reduced.

The stator (1) is designed in temperature class F. The temperature limit of the coils (8) is 155 °C. The BFK455 spring-applied brake is designed for a maximum operating time of 60 % with a reduction of the holding current.

Certificate

Type	Characteristic torque [Nm]	EC type-examination certificate
BFK455-28	2 x 1100, 2 x 1200	ABV 881 / 1
	2 x 1700, 2 x 1800	
	2 x 2065	

3.1.2 Braking

During braking, the rotor (3), which is axially movable on the hub (4), is pressed against the friction surface - via the armature plates (2) - by means of the springs (1.2). The asbestos-free friction linings ensure a high braking torque with low wear. The braking torque is transmitted between hub (4) and rotor (3) via the splines.

3.1.3 Brake release

In braked state, there is an air gap s_L between the stator (1) and the armature plate (2). To release the brake, the coil of the stator (1) is excited with the DC voltage provided. The magnetic force generated attracts the armature plate (2) towards the stator (1) against the spring force. The rotor (3) is then released and can rotate freely.

3.1.4 Release monitoring

The spring-applied brake is equipped with one microswitch (16) each per braking circuit for monitoring the switching status. When the braking circuits are released, the microswitches (16) change over. This means that the operation of the drive against the applied brake can be excluded. The microswitches can be connected both as NO and NC contacts.

For checking the correct functioning of the microswitches, we recommend to check the switching status (see Tab. 6) both when the brake is released and when the brake is applied.

3.1.5 Encapsulated design (optional)

This design not only avoids the penetration of spray water and dust, but also the spreading of abrasion particles outside the brake. This is achieved by:

- a cover seal over the armature plate and rotor.

3 Technical data

3.1.6 Project planning notes

- The brakes are dimensioned in such a way that the given characteristic torques are reached safely after a short run-in process.
- Due to the fluctuating properties of the organic friction linings used and the alternating environmental conditions, deviations of the given braking torques may occur. These must be considered by corresponding safety measures in the dimensioning process. Especially with humidity and alternating temperatures, an increased breakaway torque may occur after a long downtime.
- If the brake is used as a pure holding brake without dynamic load, the friction lining must be reactivated regularly.

3 Technical data

3.2 Rated data

3.2.1 Dimensions

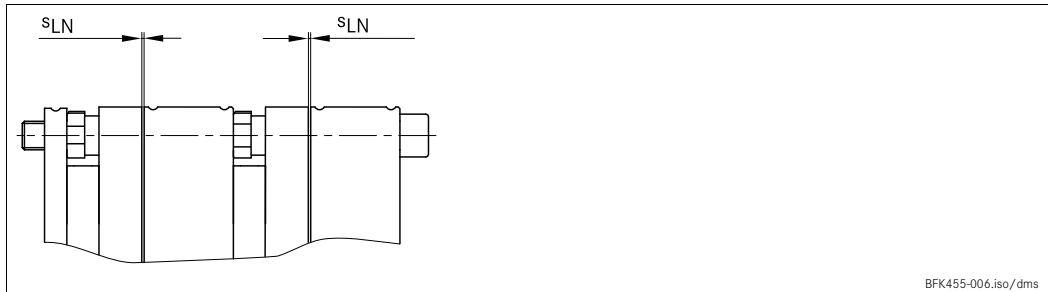

Type	Characteristic torque [Nm]	Air gap		Perm. wear [mm]	Rotor thickness		Mass of complete stator m [kg]
		$s_{LN}^{+0.05}$ [mm]	s_{Lmax} [mm]		min. [mm]	max. [mm]	
BFK455-28	2 x 1100	0.4	0.7	0.3	17.7	18	46
	2 x 1200						
	2 x 1700						
	2 x 1800						
	2 x 2065	0.6	0.2	17.8			

Type	Pitch circle		Fixing screws DIN 912		Minimum thread depth +1.0 mm		Tightening torque	
	Ø[mm]	Thread	without flange	with flange	without flange	with flange	without flange	with flange
			[mm]	[mm]	[mm]	[mm]	M_A [Nm]	M_A [Nm]
BFK455-28	314	M16	6 x M16x210	6 x M16x220	25	22.5	206	265

Tab. 1 Dimensions of the BFK455-28



Stop!

- The minimum thread depth of the end shield must be observed in any case, see Tab. 1
- If the required thread depth is not observed, the fixing screws may run into the thread root. As a result, the required preload force will no longer be built up and the brake will no longer be fixed securely!

3 Technical data

3.2.2 Electrical data

Type	Voltage		Power		Coil resistance	Current
	Release ±10%	Holding ±10%	Release	Holding	R _N ±5% [Ω]	I _L [A]
	U _L [V] DC	U _H [V] DC	P _N [W]	P _H [W]		
BFK455-28	103	52	2 x 434	2 x 108.5	2 x 24.5	2 x 4.21
	205	103	2 x 434	2 x 108.5	2 x 97	2 x 2.12
	360	180	2 x 434	2 x 108.5	2 x 298.6	2 x 1.21

Tab. 2 Coil power ratings of the BFK455-28

3.3 Rated data (selection data)

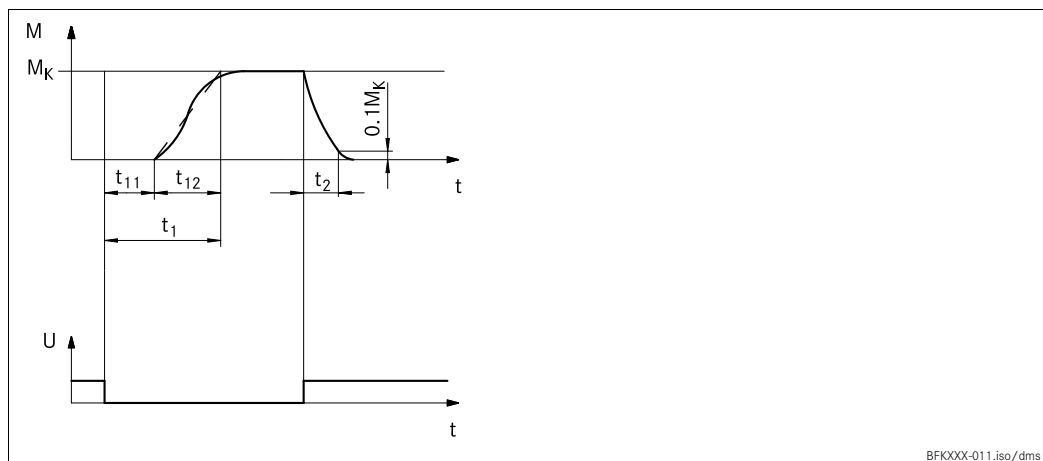

Fig. 2 Operating times of the spring-applied brakes

- t₁ Engagement time
- t₂ Disengagement time (up to M = 0.1 M_r)
- M_K Characteristic torque
- t₁₁ Reaction delay during engagement
- t₁₂ Rise time of the brake torque
- U Voltage

Type	Rated torque ¹⁾	Max. perm. switching energy QE [J]	Transition operating frequency S _{hue} [h ⁻¹]	Operating times [ms] ²⁾ at s _{LN} and 0.7 I _N				Max. speed ³⁾ n _{max.} [rpm]	
	M _K [Nm]			DC engagement ⁴⁾		Disengage			
				t ₁₁	t ₁₂	t ₁	t ₂		
BFK455-28	2 x 1100	360000	7	80	220	300	370	455	
	2 x 1200			60		280			
	2 x 1700			20		240			480
	2 x 1800			30		250			460
	2 x 2065								

1) Minimum brake torque when all components are run in with Δn=100 rpm
 2) Typical values
 3) Max. speed according to EC type-examination certificate (for higher speeds contact the manufacturer)
 4) Measured with induced voltage limitation -800 V DC

Tab. 3 Switching energy - operating frequency - operating times

3 Technical data

Engagement time

The transition from brake-torque free state to holding braking torque is not free of time lags.

Short brake engagement times are vital for emergency braking. DC switching together with a suitable spark suppressor must therefore be provided.

- The engagement times are valid for DC switching with a spark suppressor.
 - Spark suppressors are available for the rated voltages.
 - Connect the spark suppressors in parallel to the contact. If this is not admissible for safety reasons, e.g. with hoists and lifts, the spark suppressor can also be connected in parallel to the brake coil.
 - Circuit proposals:  36
- If the drive system is operated with a frequency inverter so that the brake will not be deenergised before the motor is at standstill, AC switching is also possible (not applicable to emergency braking).



Note!

If the drive system is equipped with a frequency inverter, the engagement times are greater by a factor of 5, approximately, connection  35.

Disengagement time

The disengagement time is the same for DC and AC switching. The disengagement times specified always refer to the control with overexcitation.

3 Technical data

3.4 Friction work / operating frequency

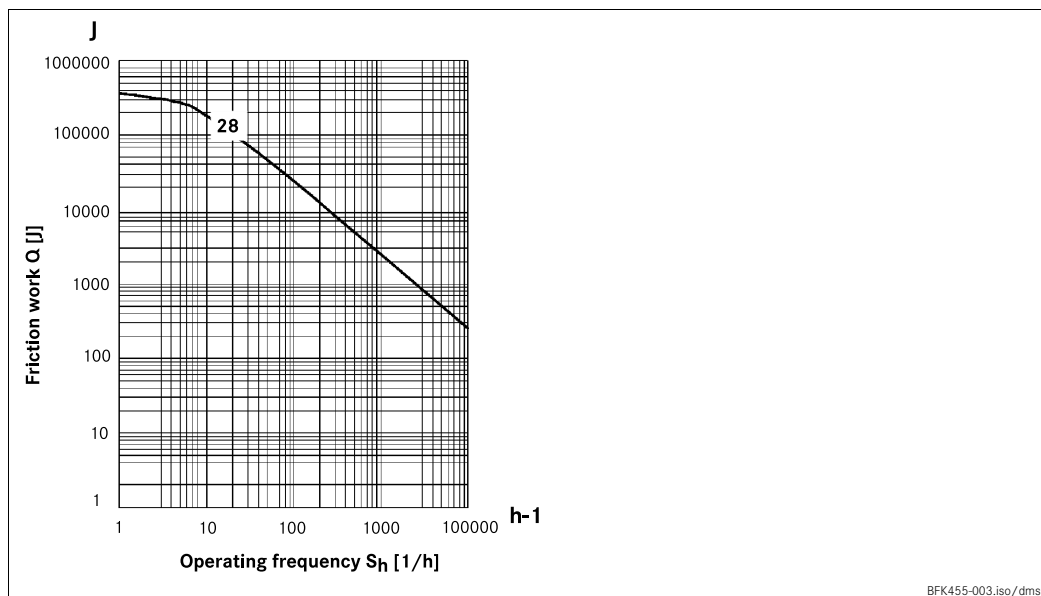

Fig. 3 Switching energy as a function of the operating frequency

$$S_{h\max} = \frac{-S_{hue}}{\ln\left(1 - \frac{Q_R}{Q_E}\right)} \quad Q_{s\max} = Q_E \left(1 - e^{\frac{-S_{hue}}{S_h}}\right)$$

The permissible operating frequency $S_{h\max}$ depends on the quantity of heat Q_R (see Fig. 3). If the operating frequency S_h is specified, the permissible quantity of heat $Q_{s\max}$ will result.

With high speed and friction work, the wear increases strongly, because very high temperatures occur at the friction faces for a short time.

3 Technical data

3.5 Emission

Electromagnetic compatibility

**Note!**

The user must ensure compliance with EMC Directive 2004/108/EC using appropriate controls and switching devices.

If an INTORQ rectifier is used for the DC switching of the spring-applied brake and if the operating frequency exceeds five switching operations per minute, the use of a mains filter is required.

If the spring-applied brake uses a rectifier of another manufacturer for the switching, it may become necessary to connect a spark suppressor in parallel with the AC voltage. Spark suppressors are available on request, depending on the coil voltage.

Heat

Since the brake converts kinetic energy as well as mechanical and electrical energy into heat, the surface temperature varies considerably, depending on the operating conditions and possible heat dissipation. Under unfavourable conditions, the surface temperature can reach 130 °C.

Noise

The switching noise during engagement and disengagement varies depending on the air gap "s_L" and the brake size.

Depending on the natural oscillation after installation, operating conditions and state of the friction faces, the brake may squeak during braking.

Others

The abrasion of the friction parts produces dust.

4 Mechanical installation



4.1 Important notes





Stop!

Toothed hub and screws must not be lubricated with grease or oil!

4.2 Necessary tools

Type	Torque key Insert for hexagon socket screws		Open-jawed spanner
			
	Measuring range [Nm]	Wrench size [mm]	Adjustment tubes - wrench size [mm]
BFK455-28	40 - 250	14	24

	Feeler gauge	Caliper gauge	Multimeter
			

4.3 Mounting

4.3.1 Important notes

Brake size	Minimum requirements for the counter friction face				
	Material ¹⁾	Evenness [mm]	Axial runout [mm]	Roughness	Others
28	S235 JR C15 EN-GJL-250	< 0.1	0.1	Rz10	<ul style="list-style-type: none"> ■ Threaded holes with minimum thread depth ≥ 16 ■ Free of grease and oil

¹⁾ In case of other materials please consult INTORQ.

Tab. 4 Counter friction face design of the end shield

The diameter of the shaft shoulder must not be bigger than the tooth root diameter of the hub.

4 Mechanical installation

4.3.2 Preparation

1. Unpack spring-applied brake.
2. Check for completeness.
3. Check nameplate data, especially rated voltage.

4.3.3 Overview

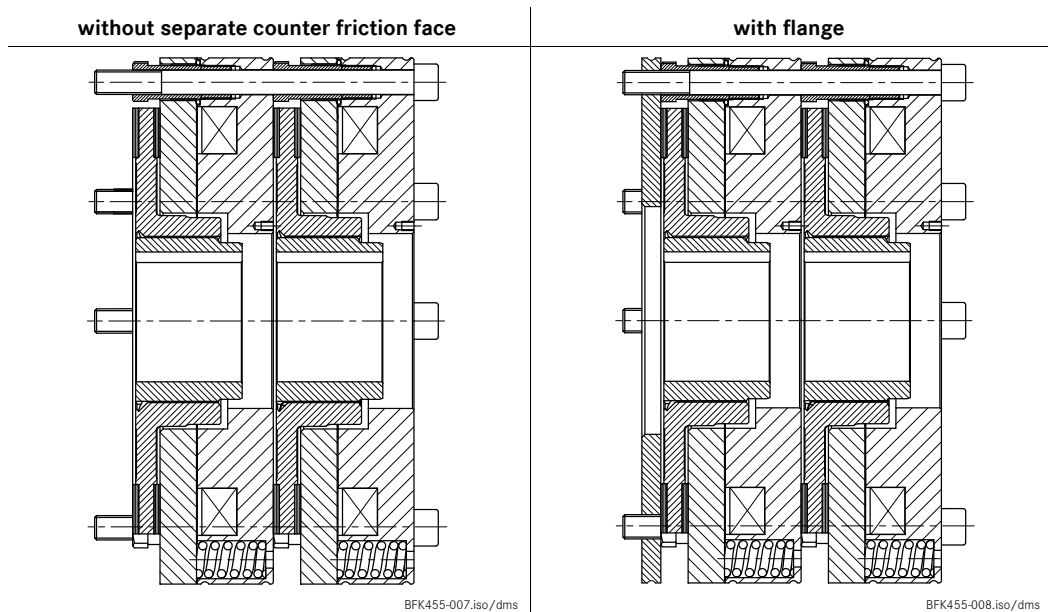

4.4 Installation



Stop!

Toothed hub and screws must not be lubricated with grease or oil!



Note!

When you have ordered a version with flange, attach the hub first (📖 23), then continue with the "Assembly of the counter friction faces".

4 Mechanical installation

Assembly of the first rotor

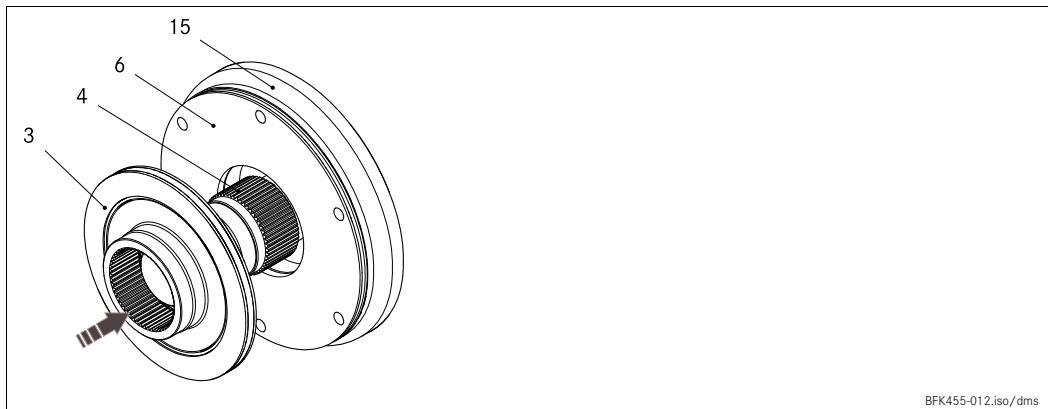

Fig. 5 Mounting of the rotor

3	Rotor	6	Flange	15	End shield
4	Hub				

6. Push the rotor (3) onto the hub (4) and check whether it can be moved by hand.



Stop!

Only in the case of rotors with mounting paste on their gear teeth:

- Remove cover films from both front ends of the rotor.
- Protect friction surfaces against contact with mounting paste!
- After the mounting, excessive mounting paste must be removed properly!

Installation of the second hub onto the shaft

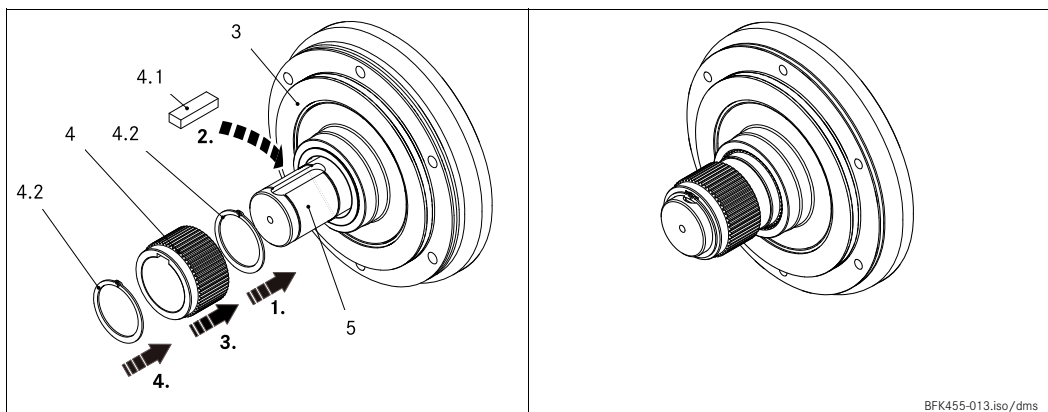

Fig. 6 Mounting of the second hub

4	Hub	3	Complete rotor	4.2	Circlip
5	Shaft	4.1	Keyway		

7. Insert second keyway (4.1) into the shaft (5) if required.
8. Press second hub (4) onto the shaft (5).
9. Secure hub (4) against axial displacement, e.g. by using a circlip (4.2).

4 Mechanical installation

Assembly of the first stator

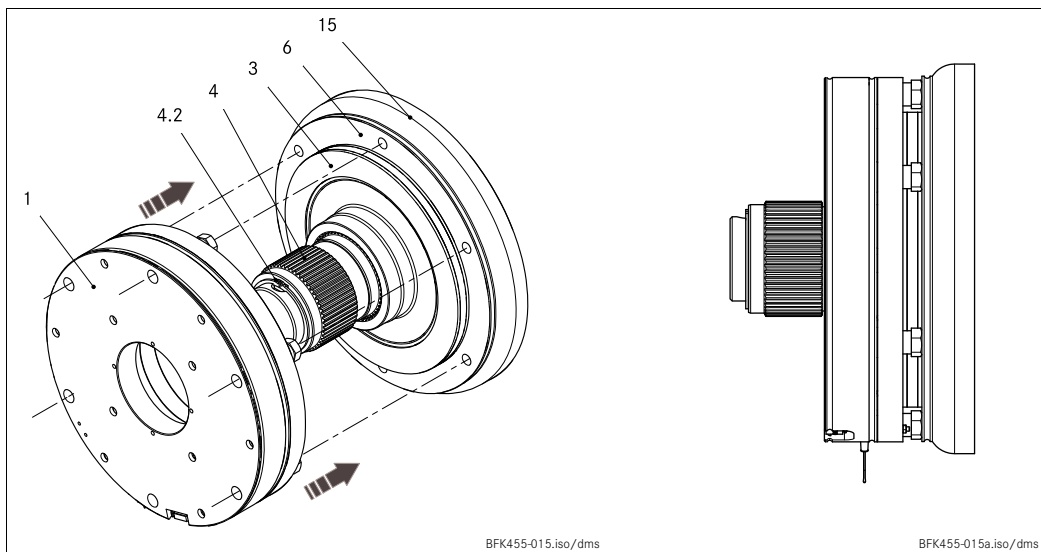

Fig. 7 Assembly of the stator

- | | | |
|-------------------|-------------|---------------|
| 1 Complete stator | 4 Hub | 6 Flange |
| 3 Complete rotor | 4.2 Circlip | 15 End shield |

10. Push the complete stator onto the shaft.
11. Align the through holes in the complete stator (1) to the threads of the fastening bore holes.

Assembly of the second rotor

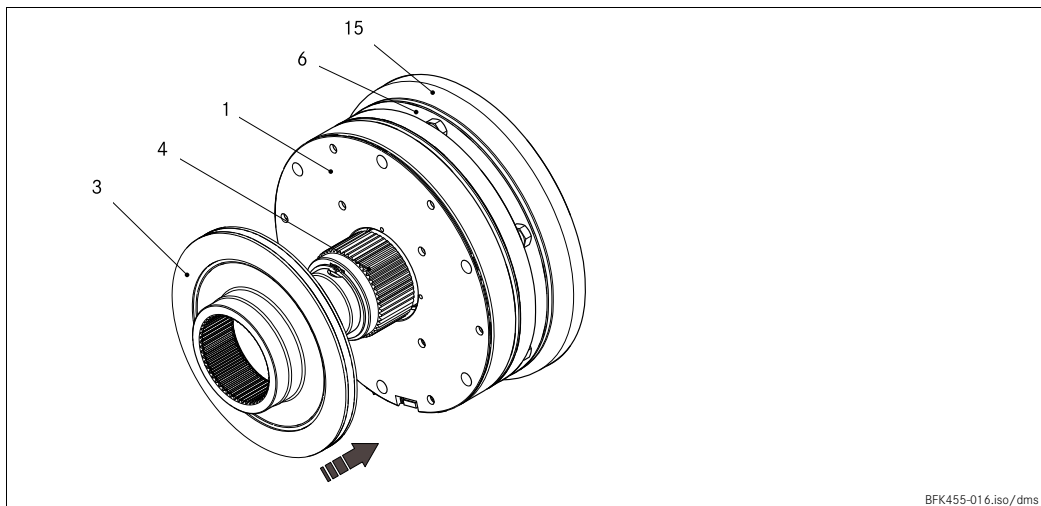

Fig. 8 Mounting of the rotor

- | | | |
|-------------------|----------|---------------|
| 1 Complete stator | 4 Hub | 15 End shield |
| 3 Complete rotor | 6 Flange | |

12. Push the complete rotor (3) onto the hub (4) and check whether it can be moved by hand.

4 Mechanical installation



Stop!

Only in the case of rotors with mounting paste on their gear teeth:

- Remove cover films from both front ends of the rotor.
- Protect friction surfaces against contact with mounting paste!
- After the mounting, excessive mounting paste must be removed properly!



Note!

If a manual release is to be installed, the required worksteps in chapter 4.5.2 Step 2 must be carried out **now!**

Assembly of the second stator

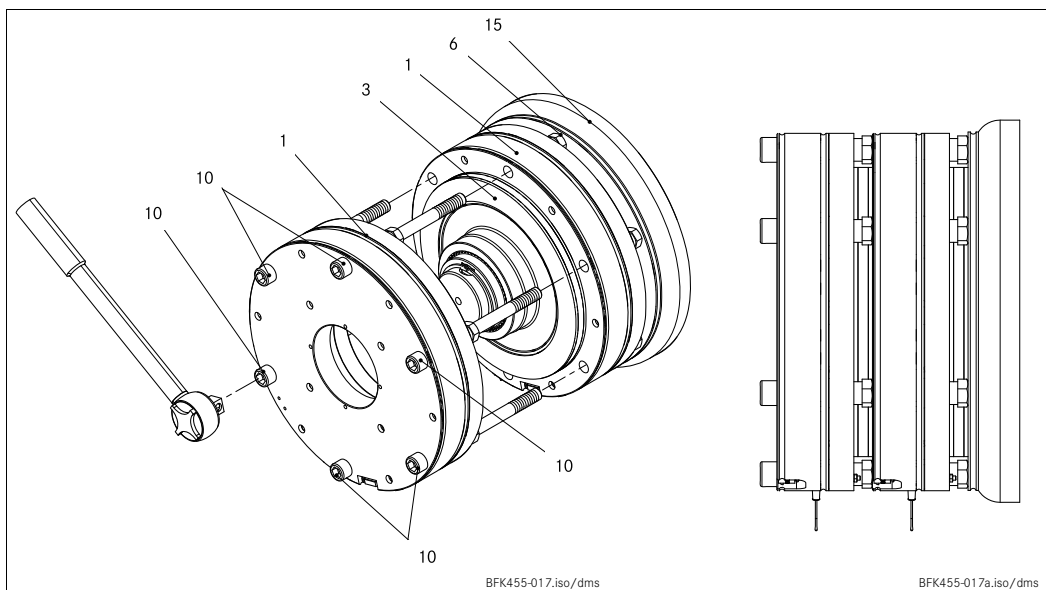

Fig. 9 Assembly of the stator

- | | | |
|-------------------|------------------|---------------|
| 1 Complete stator | 6 Flange | 15 End shield |
| 3 Complete rotor | 10 Fixing screws | |

13. Push the complete stator onto the shaft.
14. Align the through holes in the complete stator (1) to the threads of the fastening bore holes in the first stator.
15. Evenly tighten the brake with the six cheese-head screws (10) included in the scope of supply in several runs using a torque key.
16. Establish electrical connection and energise brake (📖 35).
17. Use a torque key to retighten the fixing screws (10) with the required tightening torque, 📖 16.
18. Switch off power.

4 Mechanical installation

4.4.2 Checking the air gap



Danger!

Disconnect voltage. The brake must be free of residual torque.

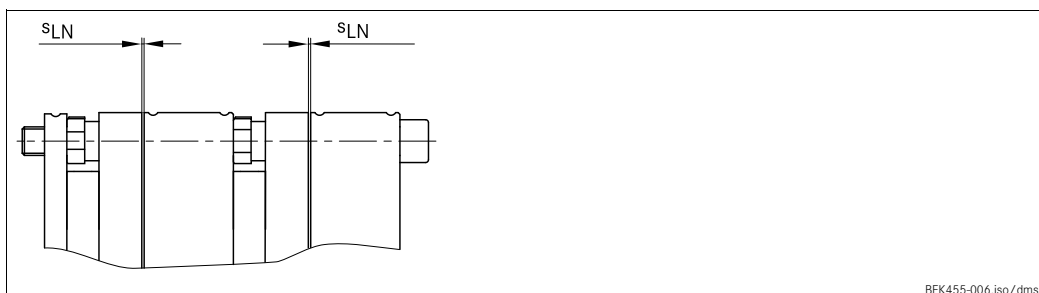

Fig. 10 Checking the air gap

1. Check the air gap near the screws (10) by means of a feeler gauge and compare the values to the values for "s_{LN}" in the table (16).



Note!

Do not insert feeler gauge more than 10 mm between armature plate (2) and stator (1.1)!

If the measured value "s_L" is outside the tolerance of "s_{Lrated}", set the dimension:

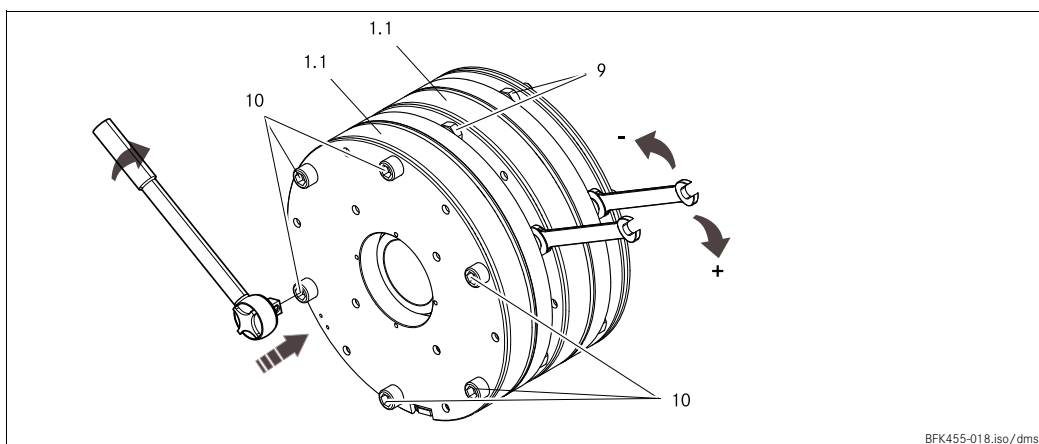

Fig. 11 Adjusting the air gap during the initial installation

1. Unbolt screws (10).





Note!

Correctly adjust the air gap using every 2nd screw (10) / sleeve bolt (9)! Turn the remaining three sleeve bolts just far enough into the stator to make sure that they do not touch the flange or the end shield. Repeat this process with the other three screws (10).

2. Slightly turn the sleeve bolts (9) using a spanner.

4 Mechanical installation

- If the air gap is too large, screw them into the stator (1.1).
 - If the air gap is too small, screw them out of the stator (1.1).
 - $\frac{1}{6}$ turn changes the width of the air gap by approx. 0.15 mm.
3. Tighten the screws (10), (for torques, see table  16).
 4. Check the air gap "s_L" near the screws (10) using a feeler gauge, ("s_{LN}" see table  16).
 5. If the difference between the measured air gap and "s_{LN}" is too large, repeat the readjustment.

4.5 Manual release



Note!

- The manual release is designed for activation via a Bowden cable.
- For activation without a Bowden cable, the lever has to be extended.
- The individual braking circuits can only be released electrically.

Manual release is installed along with the double spring-applied brake. The brake is deenergised during the process.

1. Mount first rotor (3), first complete stator (1), and second rotor (3A) according to chapter 4.4.1 steps 1. to 12.,  24 and 25.

4.5.1 Components of the hand-release

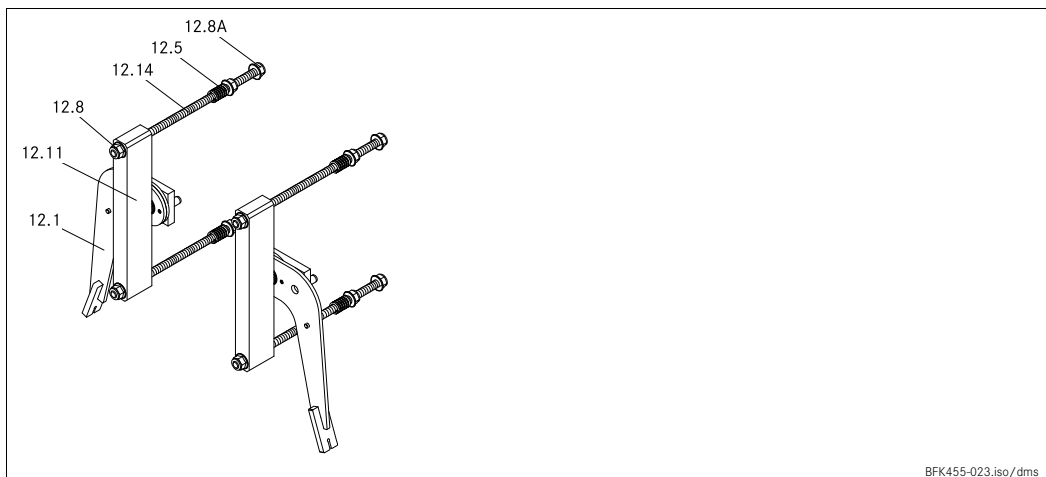

Fig. 12 Manual release

12.1	Manual release lever	12.8	Self-locking nut	12.14	Tension rod
12.5	Compression spring	12.11	Clip		

4 Mechanical installation

4.5.2 Assembly of the hand-release

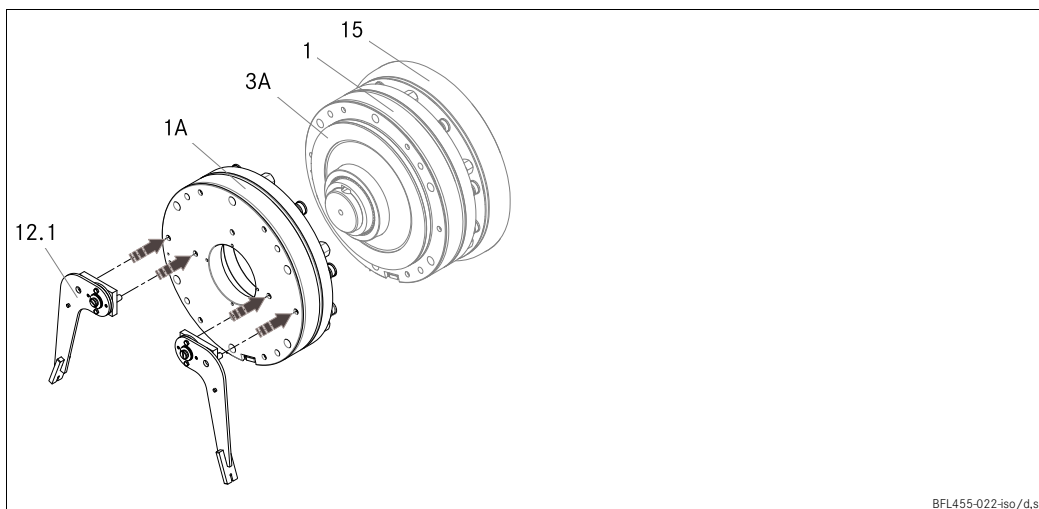

Fig. 13 Applying the manual release lever

2. Mount the two complete levers (12.1) to the second complete stator (1A). For this purpose, press the pins of the boards into the provided bore holes of the stator, use a tool if necessary.



Note!

The boards are not symmetrical. The pin with the greater distance to the axis of rotation must point to the outside. The levers also point to the outside.

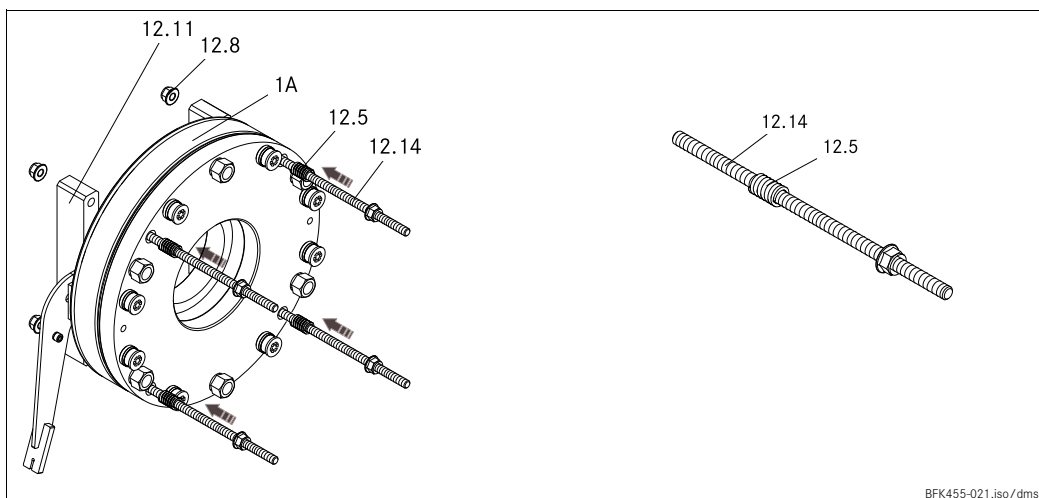

Fig. 14 Installation of the tension rods

3. Assemble four pre-assembled tension rods (12.14) with one spring (12.5) each. Carry out steps 4 and 5 separately for each side of every lever.
4. From the armature plate end, plug one pair of pre-assembled tension rods (12.14) each into the provided bore holes ($\text{\O}11$ mm) of the complete stator (1A). Insert the springs (12.5) of the tension rod into the clearing hole of the armature plate ($\text{\O}16.5$ mm) in the process.

4 Mechanical installation

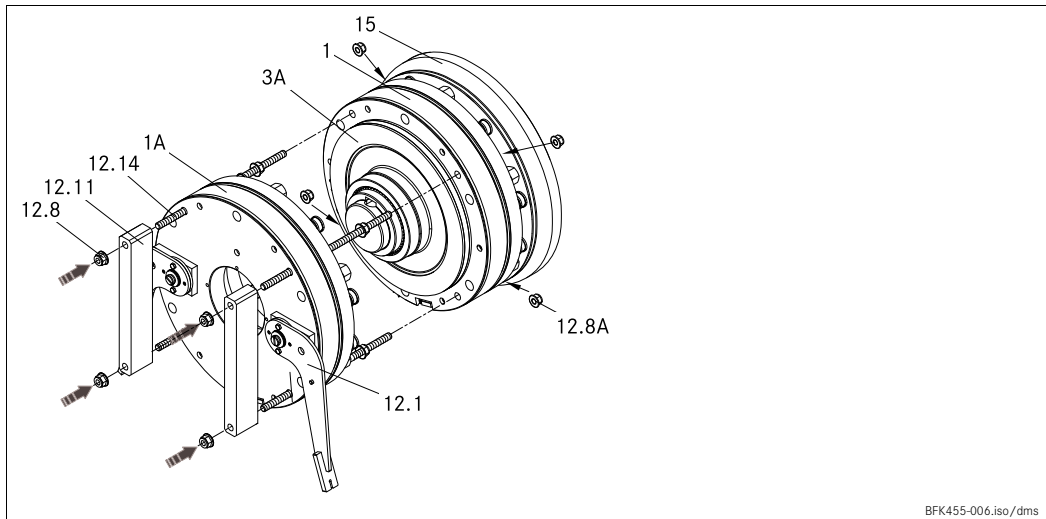

Fig. 15 Assembly parts

5. Attach the clips (12.11) with the bore holes ($\varnothing 12$ mm) to the tension rods (12.14) and tighten them with the self-locking nuts (12.8), the blind holes ($\varnothing 17$ mm) pointing in the direction of the stator and the screw heads of the complete manual release levers sinking into the clips (12.11).
6. Position the second complete stator (1A) in front of the complete stator (1). Insert the pre-assembled tension rods (12.14) into the through holes ($\varnothing 12$ mm) of the first complete stator (1) in the process.



Stop!

Tension rods must not be bent!

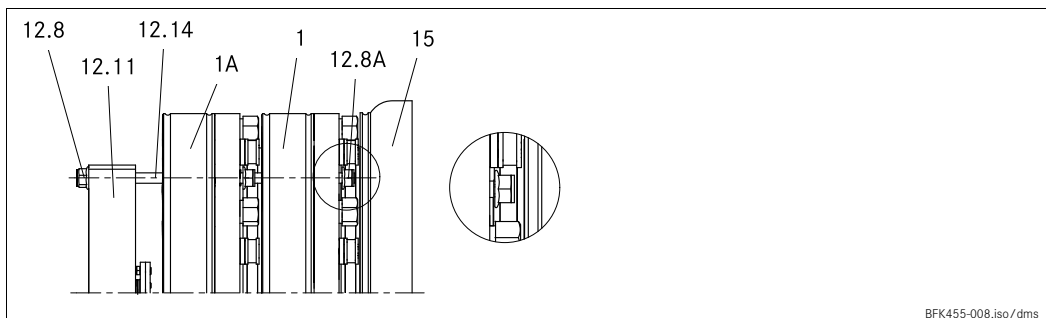



Fig. 16 Preassembly of the brake with manual release on the motor

7. Screw four self-locking nuts (12.8A) between the motor end shield and the complete stator (Pos.1) onto the tension rods (12.14) up to the point where the back side of the self-locking nut aligns with the top of the tension rod.
8. Evenly tighten the brake with the six cheese-head screws (10) included in the scope of supply in several runs using a torque key, Fig. 17.
9. Establish electrical connection and energise brake, 35.

4 Mechanical installation

10. Use a torque key to retighten the supplied fixing screws (10) with the required tightening torque,  16.
11. Switch off power.

4.5.3 Checking the air gap

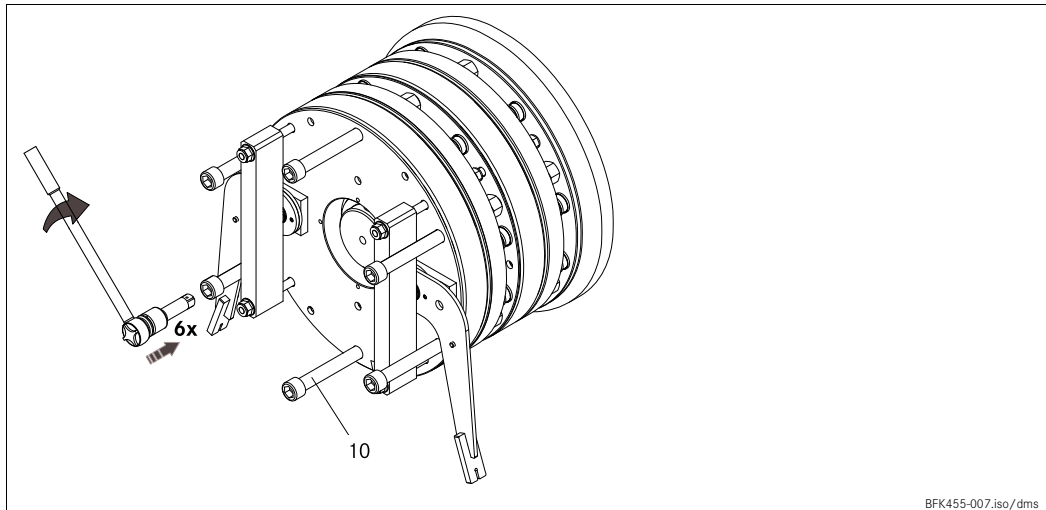

Fig. 17 Checking the air gap

12. Check the air gap by means of a feeler gauge and correct it if necessary ($s_{LN} = 0.4 \pm 0.05\text{mm}$), according to Fig. 10 and Fig. 11.

4 Mechanical installation

4.5.4 Setting the hand-release



Stop!

For setting the manual release, always lock the pre-assembled hexagon nut of the tension rod (12.14) against rotation and rotate the self-locking nuts at the ends of the tension rod only.

Carry out steps 13 and 14 separately for each side of every lever

13. Evenly tighten the self-locking nuts (Pos. 12.8) at the clips (12.11) up to the point where the nuts of the tension rod are in contact with the armature plate of the second stator (1A) (tangible resistance). Observe the parallel alignment of the clips (12.11) with the back side of the complete stator (1A) (check by means of a caliper gauge). In the case of deviations $X > 0.1\text{mm}$ (Fig. 18), correct the setting by loosening the self-locking nut (12.8) with the smaller measured value and by tightening the self-locking nut (12.8) with the greater measured value until the clips (12.11) are aligned in parallel with the back side of the brake, Fig. 18.
14. Evenly tighten the self-locking nuts on the motor end shield side up to the point where the nuts of the tension rod are in contact with the armature plate of the first stator (1) (tangible resistance).
15. Loosen the self-locking nuts (12.8) at the clips (12.11) by one revolution (360°).

Carry out steps 16 and 17 separately for each side of every lever

4 Mechanical installation

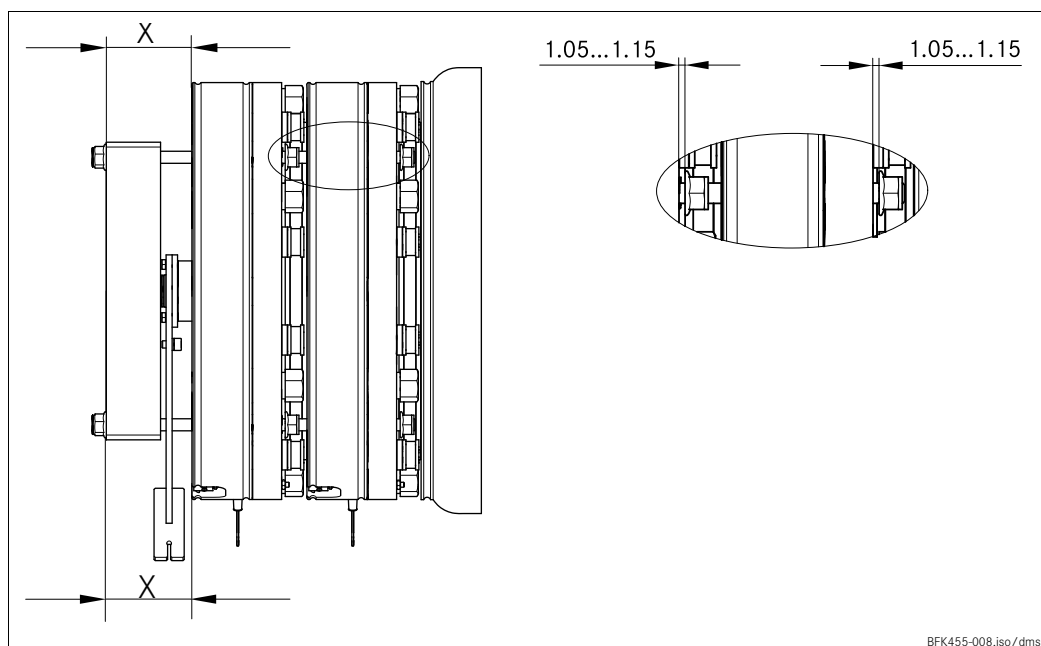

Fig. 18 Test dimensions and reference dimensions

16. Check of the correct setting (nominal dimension 1.05...1.15 mm):
 - For this purpose, position two feeler gauges of the same thickness (e.g. 1.1 mm) for each tension rod between the hexagon nuts and the complete stator and ensure that the feeler gauges can be easily moved.
17. Correct the setting if necessary until both feeler gauges can be moved by the same force.
18. Check the function of the manual release. For this purpose, attach pipe sections onto the levers and press them together to check whether the motor shaft can rotate freely.
19. Connect Bowden cable (not included in the scope of supply) and pull with approx. 420 N until the motor shaft can be freely rotated.

4 Mechanical installation

4.6 Assembly of the cover ring



Stop!

Brakes without flange require a groove at the end shield for the lip of the cover seal.

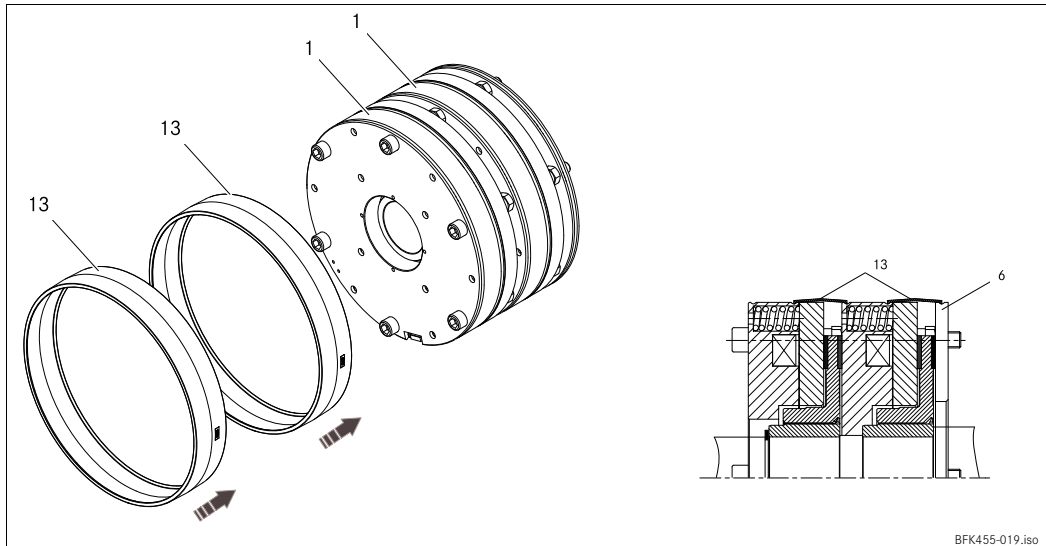

Fig. 19 Assembly of the cover ring

1 Complete stator 6 Flange 13 Cover ring

1. Disconnect electrical connection.
2. Pull cables through the cover rings (13).
3. Push cover rings (13) over the complete stators (1).
4. Press the lips of the first cover ring (13) into the groove of the complete stator (1) and flange (6) / end shield.
5. Press the lips of the second cover ring into the groove of the first and second complete stator (1).
6. Establish electrical connection again.



Stop!

Cover seal with condensation drain hole:
Attach cover seal such that condensate can run off through hole.

5 Electrical installation

5.1 Electrical connection

5.1.1 Important notes



Danger!

- Electrical connection must only be carried out by skilled personnel!
- Connections must only be made when the equipment is de-energised! Danger through unintended starts or electric shocks.



Stop!

- It must be ensured that the supply voltage corresponds to the nameplate data.
- Voltages must be adapted to the local environment!



Stop!

- If emergency switching off is carried out without the required suppressor circuit, the control unit may be destroyed.
- Observe the correct polarity of the suppressor circuit!



Stop!

- For checking the individual braking circuits, it must be possible to switch off the power supply separately for each braking circuit. For a new overexcitation during switch-on, switches K1/K3 must be opened, too.
- The suppressor circuit included in INTORQ switchgear BEG-561-□□□-□□□ (terminals 3 and 4) must not be used in lift or hoist applications. In this case, the suppressor circuit must be connected in parallel to the brake coil, 36.



Stop!

- Only operate the brake with holding current reduction to 25 % P_{max} !
- For this purpose, use e.g. INTORQ switching device BEG-561-□□□-□□□.

5 Electrical installation

5.1.2 Circuit proposals

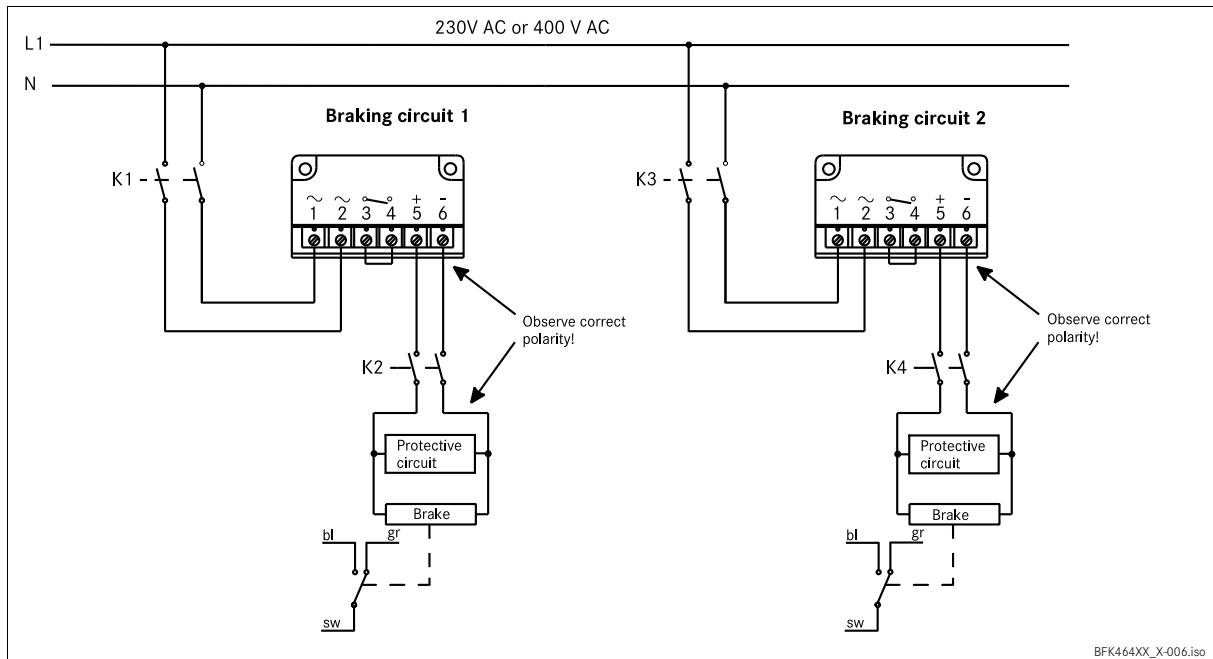

Fig. 20 INTORQ BFK455 connection diagram

Switch-on

- K2/K4 must be switched **before** or **at the same time** as K1/K3!

Switch-off

- Normal - AC switching
 - K2/K4 remain closed
 - K1/K3 open
- Emergency stop - DC switching
 - K1/K3 and K2/K4 are opened at the same time



Note!

Recommended current load of the microswitches

- DC current: 10 mA ... 100 mA at 12 V
- AC current: 10 mA ... 5 A at 12 V / max. 250 V
- Suppressor circuit: the limit voltage impacts the operating times, 17.

5.2 Bridge/half-wave rectifiers (option)

BEG-561-□□□-□□□

Bridge/half-wave rectifiers are used for the supply of electromagnetic spring-applied DC brakes which have been released for operation with such rectifiers. Any other use is only permitted with the explicit written approval of INTORQ.

Once a set overexcitation time has elapsed, the bridge/half-wave rectifiers switch over from bridge rectification to half-wave rectification.

5 Electrical installation

5.2.1 Assignment: Bridge/half-wave rectifier - brake size

Rectifier type	AC voltage	Coil voltage release/holding	Assigned brake
	[V AC]	[V DC]	
BEG-561-255-130	230 ±10%	205 / 103	BFK455-28 (205 V)
BEG-561-440-130	400 ±10%	360 / 180	BFK455-28 (360 V)

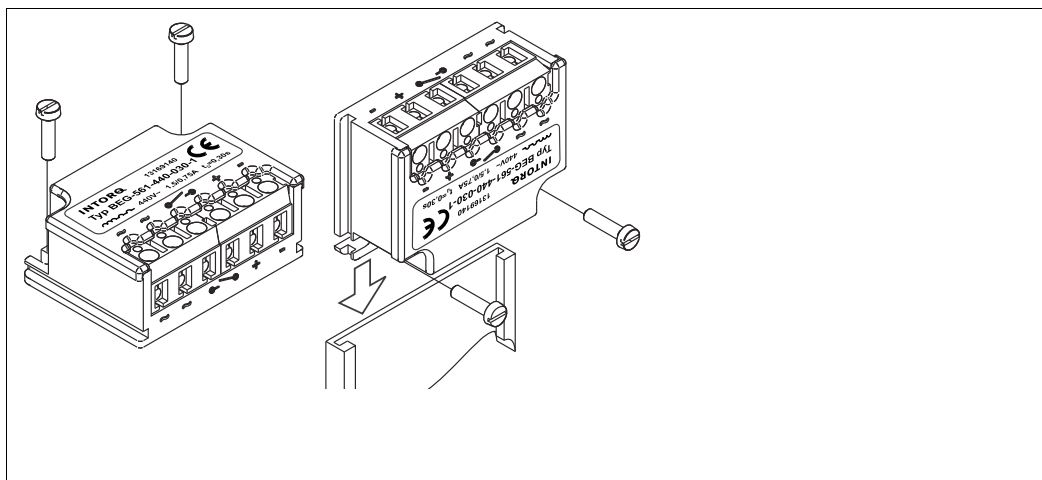

Fig. 21 BEG-561 attachment features

5.2.2 Technical data

Rectifier type	Bridge/half-wave rectifier
Output voltage for bridge rectification	0.9 x U ₁
Output voltage for half-wave rectification	0.45 x U ₁
Ambient temperature (storage/operation) [°C]	-25 ... +70

Type	Input voltage U ₁ (40 Hz ... 60 Hz)			Max. current I _{max.}		Overexcitation time t _{ov} (±20%)		
	min. [V ~]	rated [V ~]	max. [V ~]	bridge [A]	half-wave [A]	with U ₁ min [s]	with U ₁ rated [s]	with U ₁ max [s]
BEG-561-255-130	160	230	255	3.0	1.5	1.870	1.300	1.170
BEG-561-440-130	230	400	440	3.0	1.5	2.300	1.300	1.200

Input voltage U₁ (40 ... 60 Hz)

Tab. 5 Data for bridge/half-wave rectifier type BEG-561

5 Electrical installation

5.2.3 Permissible current load - ambient temperature

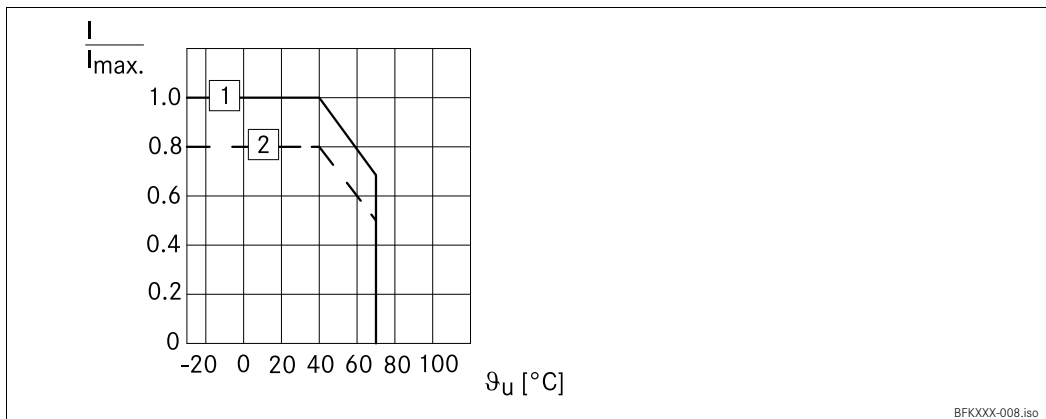

- 1 For screw assembly with metal surface (good heat dissipation)
- 2 For other assembly (e.g. glue)

5.3 Electrical connection



Danger!

The brake must only be electrically connected when no voltage is applied!



Tip!

Compare the coil voltage of the stator to the DC voltage of the installed rectifier.

6 Commissioning and operation

6.1 Important notes



Danger!

The live connections and the rotating rotor must not be touched.
The drive must not be running when checking the brake.

6.2 Function checks before commissioning

6.2.1 Operational check

Brake with microswitch



Danger!

The brake must be free of residual torque. The motor must not rotate.



Danger!

Live connections must not be touched.

1. The switching contact for the brake must be open.
2. Remove two bridges from the motor terminals to deenergise the motor.
 - Do not switch off the DC brake supply.



Stop!

If the brake is connected to the star point of the motor, the neutral conductor must also be connected to this point.

3. Apply DC voltage to the brake.
4. Measure the AC voltage at the motor terminals. It must be zero.
5. Close the switching contact for the brake.
 - The brake is released.
6. Measure the DC voltage at the brake:
 - The DC voltage measured after the overexcitation time (see bridge/half-wave rectifier,  36) must correspond to the holding voltage (see Tab. 5). A $\pm 10\%$ deviation is permissible.
7. Check air gap "s_L".
 - It must be zero and the rotor must rotate freely.
8. Check the switch position of the microswitch (see Tab. 6).

6 Commissioning and operation

9. Open the switching contact for the brake.
 - The brake is applied.
10. Check the switch position of the microswitch (see Tab. 6).
11. Switch off DC voltage for the brake.
12. Bolt bridges to the motor terminals.
13. If necessary, remove neutral conductor from star point (step 2).

Contact type	Connection	Brake released	Microswitch closed
NC contact	black / grey	yes	no
		no	yes
NO contact	black / blue	yes	yes
		no	no

Tab. 6 Switching status of microswitch

The preparations for commissioning are completed.

6.3 Commissioning

1. Switch on drive system.
2. Carry out a braking test.

6 Commissioning and operation

6.4 During operation

**Danger!**

The running rotor must not be touched.

**Danger!**

Live connections must not be touched.

- Check the brake regularly during operation. Take special care of:
 - unusual noises or temperatures
 - loose fixing elements
 - the condition of the electrical cables.
- The armature plate must be attracted and the rotor must move without residual torque.
- Measure the DC voltage at the brake.
 - The DC voltage measured after the overexcitation time (see bridge/half-wave rectifier,  36) must correspond to the holding voltage (see Tab. 5). A $\pm 10\%$ deviation is permissible.
- In the event of failures, refer to the troubleshooting table in chapter 8. If the fault cannot be eliminated, please contact the aftersales service.

7 Maintenance/repair

7.1 Wear of spring-applied brakes

INTORQ spring-applied brakes are wear-resistant and designed for long maintenance intervals. The friction lining and the mechanical brake components are subject to function-related wear. For safe and trouble-free operation, the brake must be checked at regular intervals or, if necessary, be replaced,  43.



Stop!

Braking torque reduction

The air gap must not be re-adjusted after it has been correctly adjusted during the initial installation of the brake on the motor! This could result in a reduction of the braking torque.

The following table describes the different causes of wear and their effects on the components of the spring-applied brake. The important influencing factors must be quantified so that the service life of the rotor and brake can be calculated and that the maintenance intervals to be prescribed can be specified precisely. The most important factors in this context are the applied friction energy, the initial speed of braking and the operating frequency. If several of the causes of friction lining wear occur in an application at the same time, the influencing factors are to be added together when the amount of wear is calculated.

Component	Cause	Effect	Influencing factors
Friction lining	Braking during operation	Wear of friction lining	Friction work
	Emergency stops		
	Overlapping wear during start and stop of drive		
	Active braking via the drive motor with support of brake (quick stop)		Number of start/stop cycles
	Starting wear in case of motor mounting position with vertical shaft, even when the brake is not applied		
Armature plate and counter friction face	Rubbing of brake lining	Run-in of armature plate and counter friction face	Friction work
Splining of brake rotor	Relative movements and shocks between brake rotor and brake shaft	Wear of splining (primarily on the rotor side)	Number of start/stop cycles
Brake support	Load alternation and jerks in the backlash between armature plate, sleeve bolts and guide bolt	Breaking of armature plate, sleeve bolts and guide bolt	Number of start/stop cycles, braking torque
Springs	Axial load cycle and shear stress of springs through radial backlash on reversal of armature plate	Reduced spring force or fatigue failure	Number of switching operations of brake

Tab. 7 Causes for wear

7 Maintenance/repair



7.2 Inspections

To ensure safe and trouble-free operation, spring-applied brakes must be checked and maintained at regular intervals. Servicing can be made easier if good accessibility of the brakes is provided in the plant. This must be considered when installing the drives in the plant.

Primarily, the necessary maintenance intervals for industrial brakes result from the load during operation. When calculating the maintenance interval, all causes for wear must be taken into account, [42]. For brakes with low loads such as holding brakes with emergency stop, we recommend a regular inspection at a fixed time interval. To reduce the cost, the inspection can be carried out along with other regular maintenance work in the plant if necessary.

If the brakes are not maintained, failures, production losses or damage to the system may occur. Therefore, a maintenance concept adapted to the particular operating conditions and brake loads must be defined for every application. For the spring-applied brakes, the maintenance intervals and maintenance operations listed in the below table must be provided. The maintenance operations must be carried out as described in the detailed descriptions.

7.2.1 Maintenance intervals

Type BFK455-28	Time interval	
	for service brakes: <ul style="list-style-type: none"> ■ according to service life calculation ■ or else every six months ■ after 4000 operating hours at the latest 	for holding brakes with emergency stop: <ul style="list-style-type: none"> ■ at least every two years ■ after 1 million cycles at the latest
	Maintenance	
	Inspections if brake is built-on: <ul style="list-style-type: none"> ■ Check release function and control [44] ■ Measure air gap [45] ■ Measure rotor thickness (replace rotor, if necessary) [45] ■ Thermal damage of armature plate or flange (dark-blue tarnishing) 	Inspections after brake has been removed: <ul style="list-style-type: none"> ■ Check clearance of the rotor gearing (replace worn-out rotors) [45] ■ Play of torque plate at sleeve bolts and armature plate ■ Check springs for damage ■ Check armature plate and flange/end shield <ul style="list-style-type: none"> - Levelness < 0.1 mm - Max. run-in depth = rated air gap of brake size

7 Maintenance/repair

7.2.2 Release / voltage

1. Start motor and control system!



Danger!

The running rotor must not be touched.



Danger!

Live connections must not be touched.

2. Observe air gap "s_L" during operation of the drive. The air gap must be zero.
3. Measure the DC voltage at the brake.
 - The DC voltage measured after the overexcitation time (see bridge/half-wave rectifier, 36 must correspond to the holding voltage 37. A ±10 % deviation is permissible.

7.3 Maintenance operations



Note!

Brakes with defective armature plates, cheese head screws, springs or counter friction faces must always be replaced completely.

Generally observe the following for inspections and maintenance works:

- Remove oil and grease linked impurities using brake cleaning agents, if necessary, replace brake after identifying the cause of the contamination. Dirt deposits in the air gap between stator and armature plate impair the function of the brake and must be removed.
- After replacing the rotor, the original braking torque will not be reached until the run-in operation of the friction surfaces has been completed. After replacing the rotor, run-in armature plates and counter friction faces have an increased initial rate of wear.

7.3.1 Checking the rotor thickness



Danger!

The motor must not run during the check.

1. Stop motor and control system!
2. Remove the motor cover and seal ring, if mounted.
3. Measure the rotor thickness using a caliper gauge.
4. Compare the measured rotor thickness with the minimally permissible rotor thickness, 16.
5. If necessary, replace the complete rotor, 45 for description.

7 Maintenance/repair

7.3.2 Checking the air gap



Danger!

The motor must not run during the check.

1. Stop motor and control system!
2. Measure air gap "s_L" near the fixing screws between armature plate and stator using a feeler gauge.
3. Compare the measured air gap with the maximum permissible air gap "s_{Lmax}", 16.
4. Always replace both rotors if required.

7.3.3 Rotor replacement



Danger!

The brake must be free of residual torque.

1. Switch off voltage!
2. Disconnect the supply cable.
3. Loosen the screws evenly and remove them completely.
4. Remove the complete stator from the end shield. Observe the supply cable.
5. Pull the complete rotor off the hub.
6. Check hub teeth.
7. Replace the hub as well if worn.
8. Check the friction surface at the end shield. In case of strong scoring at the flange, replace the flange. If scoring occurs at the end shield, re-finish end shield.
9. Measure rotor thickness (new rotor) and sleeve bolt head with a caliper gauge.
10. Calculate the gap between the stator and the armature plate as follows:

$$\text{Gap} = \text{rotor thickness} + s_{LN} - \text{head height}$$

$$s_{LN} \text{ 16}$$

11. Unscrew the sleeve bolts evenly until the calculated gap between stator and armature plate is reached.
12. Install and adjust new rotor and stator, 23.
13. Reconnect the supply cable.

7 Maintenance/repair

7.4 Spare-parts list

- Only parts with item numbers are available.
 - The item numbers are only valid for the standard design.
- Please include the following information with the order:
 - Order number of the brake
 - Position number of the spare part

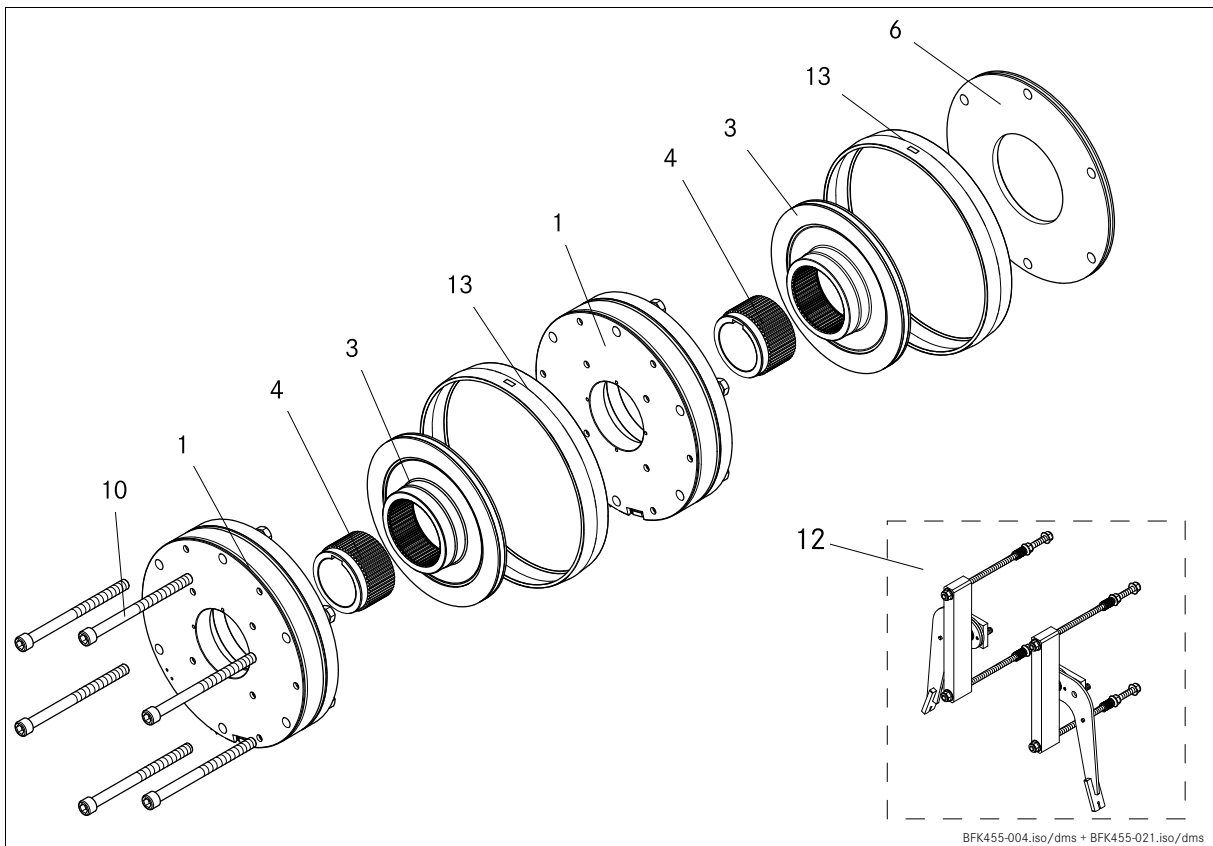

Fig. 22 BFK455-28 spring-applied brake

Pos.	Name	Variant
1	Complete stator	Voltage
3	Complete rotor Complete rotor, noise-reduced	
4	Hub	Bore diameter
6	Flange	
10	Fixing screws Cheese head screw set DIN912	for mounting to the motor for flange with through hole
12	Complete manual release	
13	Cover ring	

7 Maintenance/repair

7.5 Spare parts order

Complete stator

- Size** 28
- Voltage** 103 V / 52 V 205 V / 103 V 360 V / 180 V
- Braking torque** _____ Nm (see torque ranges)
- Cable length** Standard (1000 mm)
- Armature plate** Standard
- Microswitch** Monitoring of the switching function

Component parts

- Rotor** Aluminium Noise-reduced (rotor with sleeve)
- Hub** _____ mm (for hole diameter see dimensions)
- Fixing screw set** for mounting
 for mounting with flange
- Counter friction face** Flange
- Sealing** Cover ring
- Complete manual release**



Electrical accessories

Rectifier type: For selection, see chapter 5.2.1

- Rectifier** BEG-561-255-130
 BEG-561-440-130

8 Troubleshooting and fault elimination

If any malfunctions should occur during operation, please check the possible causes using the following table. If the fault cannot be eliminated by one of the listed measures, please contact the aftersales service.

Fault	Cause	Remedy
Brake cannot be released, air gap is not zero	Coil interruption	<ul style="list-style-type: none"> ■ Measure coil resistance using multimeter: <ul style="list-style-type: none"> - If resistance is too high, replace the complete stator.
	Coil has interturn fault or short circuit to ground	<ul style="list-style-type: none"> ■ Measure coil resistance using multimeter: <ul style="list-style-type: none"> - Compare measured resistance to rated resistance. For values, see  16. If the resistance is too low, replace the complete stator. ■ Check coil for short circuit to ground using a multimeter: <ul style="list-style-type: none"> - Replace the complete stator if short circuit to ground is detected. ■ Check brake voltage (see "defective rectifier, voltage too low").
	Wiring incorrect or defective	<ul style="list-style-type: none"> ■ Check and correct wiring. ■ Check cable continuity using a multimeter: <ul style="list-style-type: none"> - Replace defective cable.
	Rectifier defective or wrong	<ul style="list-style-type: none"> ■ Measure rectifier DC voltage using a multimeter. If DC voltage is zero: <ul style="list-style-type: none"> ■ Check AC rectifier voltage. If AC voltage is zero: <ul style="list-style-type: none"> - Apply voltage, - check fuse, - check wiring If AC voltage is ok: <ul style="list-style-type: none"> - Check rectifier - replace defective rectifier If DC voltage is too low: <ul style="list-style-type: none"> - Check rectifier - If diode is defective, use suitable new rectifier ■ Check coil for fault between turns and short circuit to ground. ■ If the rectifier defect occurs again, replace the entire stator, even if you cannot find any fault between turns or short circuit to ground. The fault may occur later during heating-up.
	Incorrect microswitch wiring	Check microswitch wiring and correct it.
	Incorrect microswitch setting	Replace the complete stator and complain about the incorrect microswitch setting to the manufacturer.
	Air gap too big	<ul style="list-style-type: none"> ■ For adjustable brakes: <ul style="list-style-type: none"> - Readjust air gap. ■ For non-adjustable brakes: <ul style="list-style-type: none"> - Replace all rotors.
Rotor cannot rotate freely	Air gap s_L too small	Readjust air gap s_L ,  27.

8 Troubleshooting and fault elimination

Fault	Cause	Remedy
Rotor not thick enough	Rotor has not been replaced in time	Replace rotor (☐ 45)
Voltage is not zero during functional test (6.2.2 or 6.2.3)	Incorrect microswitch wiring	Check microswitch wiring and correct it
	Defective microswitch or incorrect setting	Replace the complete stator and return complete defective unit to the manufacturer
Voltage too high	Brake voltage does not match the rectifier	Adapt rectifier and brake voltage to each other.
Voltage too low	Brake voltage does not match the rectifier	Adapt rectifier and brake voltage to each other.
	Defective rectifier diode	Replace rectifier by a suitable new one.
AC voltage is not mains voltage	Fuse is missing or defective	Select a connection with proper fusing.
	Incorrect microswitch wiring	Check microswitch wiring and correct it
	Defective microswitch or incorrect setting	Replace the complete stator and return complete defective unit to the manufacturer



Notizen



Notizen

 **INTORQ GmbH & Co KG**

Germany

Postfach 1103

D-31849 Aerzen

Wülmsers Weg 5

D-31855 Aerzen

 +49 5 154 70534-444

 +49 5 154 70534-200

 info@intorq.com

 **INTORQ (SHANGHAI) Co., Ltd**

China

No. 600, Xin Yuan Road

Building No. 6 / Zone B

Nan Hui District, Lingang

Shanghai, China 201306

应拓柯制动器（上海）有限公司

中国

新元南路600号6号楼1楼B座

上海 南汇 201306

 +86 21 20363-810

 +86 21 20363-805

 info@cn.intorq.com

 **INTORQ US Inc.**

USA

300 Lake Ridge Drive SE

Smyrna, GA 30082

 +1 678 309-1155

 +1 678 309-1157

 info@us.intorq.com