

# CAPT LOCK PRODUCTS PRICE GUIDE

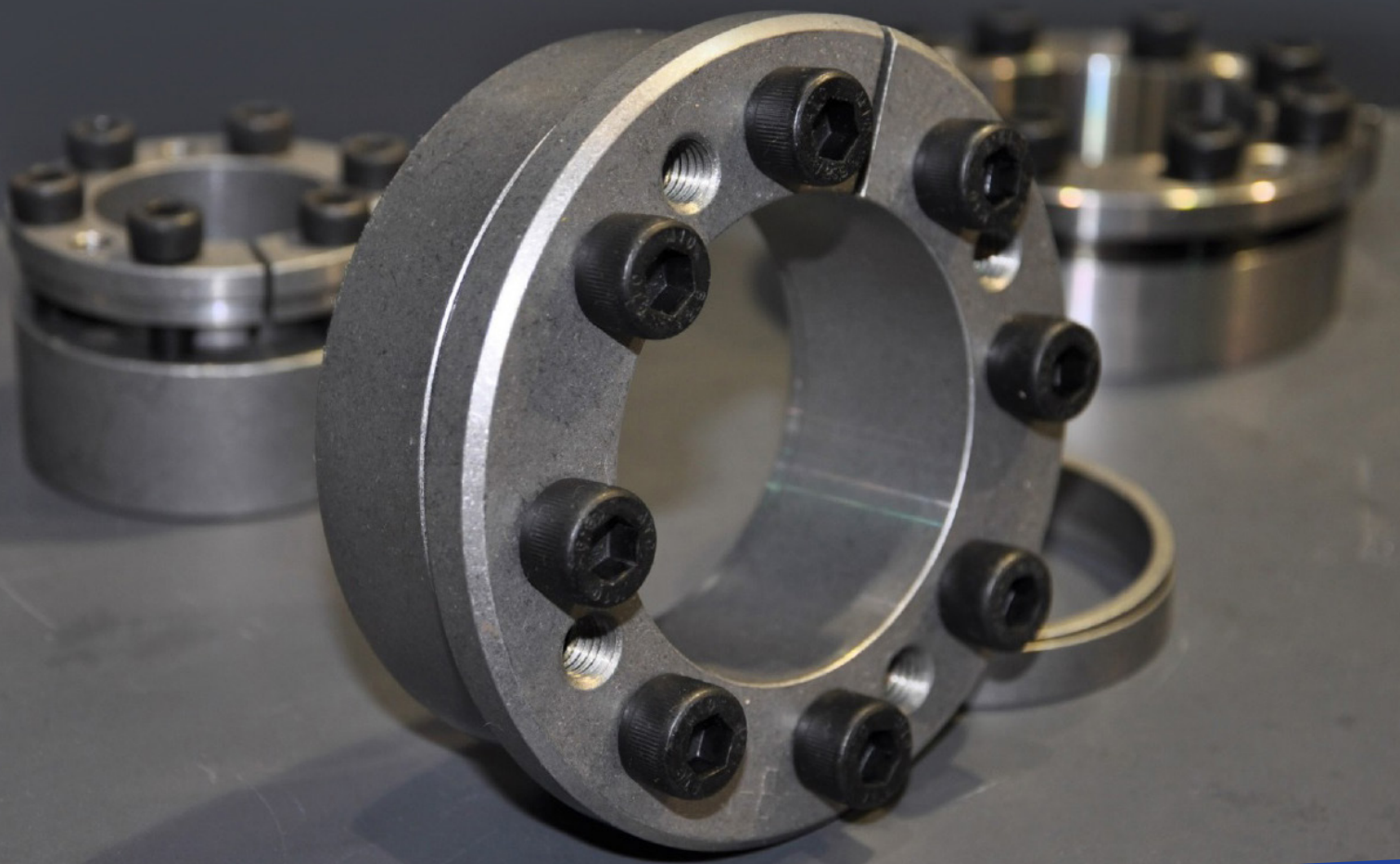

# CAPT-Locks Product Range

Chain & Drives are pleased to announce that a complete range of locking hubs is now available. Stock of the B Series Single, D Series Double and FA2 shaft locking hubs that are interchangeable with leading brands including Tollok, Fenlock, Sati, KTR, Ringbloc and Tsubaki. As always GBPower is bringing you leading brands at incredibly competitive prices and backing that up with technical knowledge and great service.

Contact Chain and Drives for price and availability of the CAPT Lock for your next requirement. Save your customer time and money with quick and efficient shaft connection without keyways. Quality manufacture, simple assembly and disassembly and competitive pricing will help make the CAPT Locks your preferred choice.



## CAPT-LOCKS

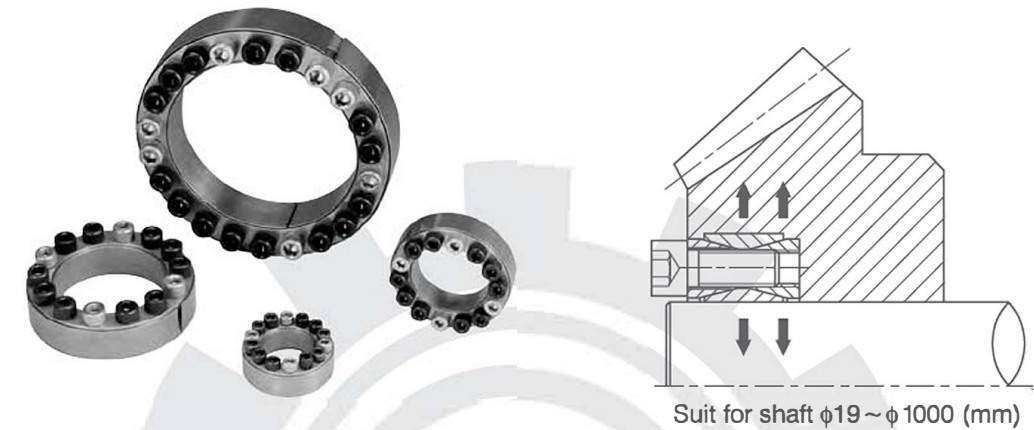

**B CAPT-Locks** are the commonly used type. The machining precision of the connect parts can be reduced if this type is used which in turn reduces the machining cost.

Using B type provides easy on and easy off capabilities, has excellent installation and can be self installed. The connection function depends on its impacted power and frictional power among the bore and the shaft to achieve non-clearance joint and no key is necessary so that some over elaborate work such as key machining, pressing installation and hot installation, etc can be avoided. The working efficiency and the lifetime of the machining parts can be raised.

Nomenclature for CAPT-LOCK type B

**CL 60 X 90 B**

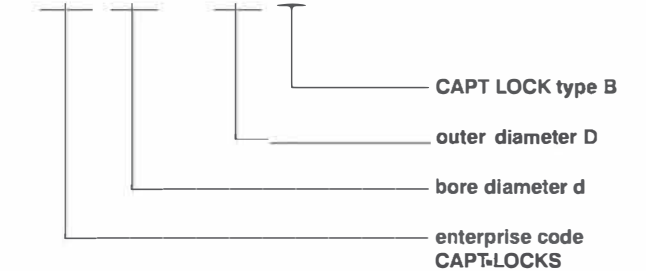

## B CAPT-LOCKS



**SALES AND ENGINEERING**  
Unit 1, 45 Inspiration Drive  
Wangara WA 6065

**WORKSHOP AND DISTRIBUTION**  
22 Beneficial Way  
Wangara WA 6065

**SALES AND ENGINEERING NSW**  
Unit 7 & 8, 4 Abbott Road  
Seven Hills NSW 2147  
T +61 2 9674 8611 F +61 2 9674 8363

PO Box 1343, Wangara WA 6947  
P +61 8 9303 4966 F +61 8 9303 4977  
[info@chainanddrives.com.au](mailto:info@chainanddrives.com.au)



# CAPT-LOCKS

**B**

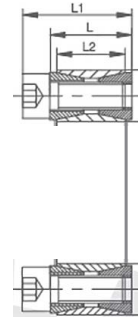

## B CAPT-LOCKS®

Table:1

Catalog	Fundamental dimensions			SizesxN	Rated load		Ps	Ph	Ma	G
	L2	L	L1		Ft(Kn)	Mt(Kn.m)				
CL19x47B	17	20	26	M6x8	27	0.24	213	90	14	0.25
CL20x47B	17	20	26	M6x8	27	0.27	210	90	14	0.24
CL22x47B	17	20	26	M6x8	27	0.30	195	90	14	0.23
CL25x50B	17	20	26	M6x9	30	0.38	190	95	14	0.25
CL28x55B	17	20	26	M6x10	33	0.47	185	95	14	0.30
CL30x55B	17	20	26	M6x10	33	0.50	175	95	14	0.29
CL35x60B	17	20	26	M6x12	40	0.70	180	105	14	0.32
CL38x63B	17	20	26	M6x14	46	0.88	185	105	14	0.33
CL40x65B	17	20	26	M6x14	46	0.92	180	110	14	0.34
CL42x72B	20	24	32	M8x12	73	1.36	200	117	35	0.48
CL45x75B	20	24	32	M8x12	73	1.62	210	125	35	0.57
CL50x80B	20	24	32	M8x12	73	1.77	190	115	35	0.60
CL55x85B	20	24	32	M8x14	83	2.27	200	130	35	0.63
CL60x90B	20	24	32	M8x14	83	2.47	180	120	35	0.69
CL65x95B	20	24	32	M8x16	93	3.04	190	130	35	0.73
CL70x110B	24	28	38	M10x14	132	4.60	210	130	70	1.26
CL75x115B	24	28	38	M10x14	131	4.90	195	125	70	1.33
CL80x120B	24	28	38	M10x14	131	5.20	180	120	70	1.40
CL85x125B	24	28	38	M10x16	148	6.30	195	130	70	1.49
CL90x130B	24	28	38	M10x16	147	6.60	180	125	70	1.53
CL95x135B	24	28	38	M10x18	167	7.90	195	135	70	1.62
CL100x145B	29	33	45	M12x14	192	9.60	195	135	125	2.01
CL105x150B	29	33	45	M12x14	190	9.98	185	130	125	2.10
CL110x155B	29	33	45	M12x14	191	10.50	180	125	125	2.15
CL120x165B	29	33	45	M12x16	218	13.10	185	135	125	2.35
CL125x170B	29	33	45	M12x18	220	13.78	180	130	125	2.95
CL130x180B	34	38	50	M12x20	272	17.60	165	120	125	3.51
CL140x190B	34	38	50	M12x22	298	20.90	165	125	125	3.85
CL150x200B	34	38	50	M12x24	324	24.20	170	125	125	4.07
CL160x210B	34	38	50	M12x26	350	28.00	170	130	125	4.30
CL170x225B	38	44	58	M14x22	386	32.80	160	120	190	5.78
CL180x235B	38	44	58	M14x24	420	37.80	165	125	190	6.05
CL190x250B	46	52	66	M14x28	490	46.50	150	115	190	8.25
CL200x260B	46	52	66	M14x30	525	52.50	150	115	190	8.65
CL210x275B	50	56	72	M16x24	599	62.89	151	115	295	10.10



# CAPT-LOCKS

**B**

## B CAPT-LOCKS®

Table:2

Catalog	Fundamental dimensions			SizesxN	Rated load		Ps	Ph	Ma	G
	L2	L	L1		Ft(Kn)	Mt(Kn.m)				
CL220x285B	50	56	72	M16x26	620	68.00	150	115	295	11.22
CL240x305B	50	56	72	M16x30	715	85.50	160	125	295	12.20
CL250x315B	50	56	72	M16x32	768	96.00	162	125	295	12.70
CL260x325B	50	56	72	M16x34	800	104.00	165	130	295	13.20
CL280x355B	60	66	84	M18x32	915	128.00	145	115	405	19.20
CL300x375B	60	66	84	M18x36	1020	153.00	150	120	405	20.50
CL320x405B	72	78	98	M20x36	1310	210.00	150	120	580	29.60
CL340x425B	72	78	98	M20x36	1310	224.00	145	115	580	31.10
CL360x455B	84	90	112	M22x36	1630	294.00	145	115	780	42.20
CL380x475B	84	90	112	M22x36	1620	308.00	135	110	780	44.00
CL400x495B	84	90	112	M22x36	1610	322.00	130	105	780	46.00
CL420x515B	84	90	112	M22x40	1780	374.00	135	110	780	50.00
CL450x555B	96	102	126	M24x40	2050	461.25	124	100	1000	65.00
CL480x585B	96	102	126	M24x42	2160	518.40	124	100	1000	71.00
CL500x605B	96	102	126	M24x44	2240	560.00	123	100	1000	72.60
CL530x640B	96	102	126	M24x45	2330	617.00	121	110	1000	83.60
CL560x670B	96	102	126	M24x48	2440	680.00	120	110	1000	85.00
CL600x710B	96	102	126	M24x50	2580	775.00	118	100	1000	91.00
CL630x740B	96	102	126	M24x52	2680	844.00	117	105	1000	94.00
CL670x780B	96	102	126	M24x56	2820	944.00	116	100	1000	101.0
CL710x820B	96	102	126	M24x60	2970	1054.0	115	100	1000	106.0
CL750x860B	96	102	126	M24x62	3130	1173.0	115	100	1000	112.0
CL800x910B	96	102	126	M24x66	3260	1300.0	112	100	1000	118.0
CL850x960B	96	102	126	M24x70	3500	1487.0	113	100	1000	125.0
CL900x1010B	96	102	126	M24x75	3680	1650.0	112	100	1000	132.0
CL950x1060B	96	102	126	M24x80	3870	1838.0	112	100	1000	139.0
CL1000x1110B	96	102	126	M24x82	4000	2000.0	110	100	1000	146.0

The items in table 1 are standard products in stock . The items in table 2 will be produced against orders.

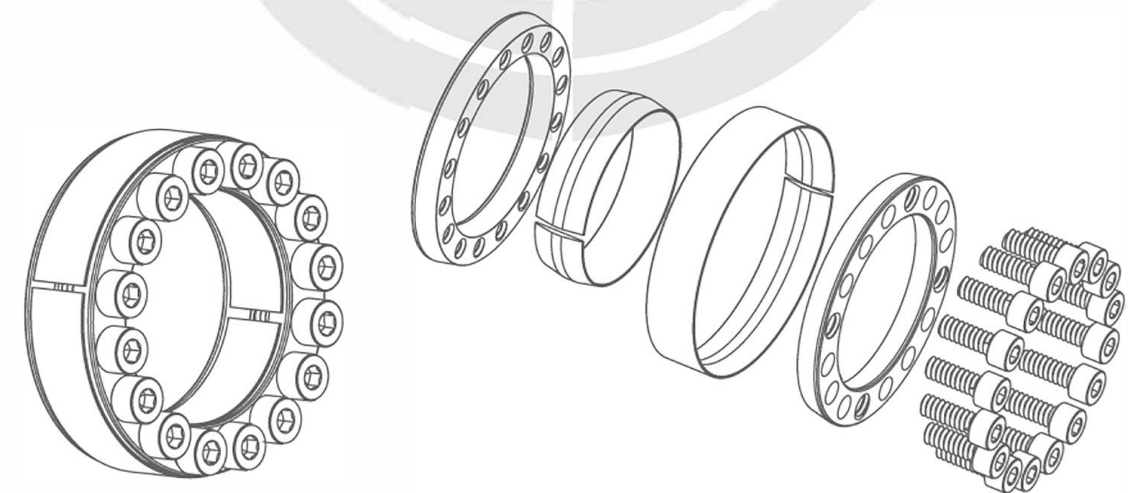

**Key elements for designing and calculation B**

1. Determine max torque and max axial load

$$M_{max} = \frac{30000H}{\pi \cdot n} \cdot K \text{ (N m)}$$

$$F_{max} = F \cdot K$$

H—Transmission power KW  
 n—rotational speed r/min  
 K—coefficient needed  
 Used coefficient sheet for K

Sheet for coefficient used K

No shock load, transmitting with little inertia	1.5–2.5
Slight shock load, transmitting with middle inertia	2.0–4.0
Big shock load, transmitting with heavy inertia	3.0–5.0

2. Calculate synthetic load and transmitted torque

$$M_h = \sqrt{M_{max}^2 + \left(\frac{d}{2} \times F_{max}\right)^2}$$

M<sub>max</sub>—Required transmit torque Nm  
 F<sub>max</sub>—Required transmit axial force N  
 M<sub>h</sub>—synthetic transmit torque Nm  
 d—Transmission shaft diameter mm  
 M<sub>t</sub>—CAPT lock rated transmitted torque Nm

M<sub>t</sub> ≥ M<sub>h</sub> can be used.  
 M<sub>t</sub> < M<sub>h</sub> need bigger type of CAPT lock or to be install by two CAPT locks or more together

3. Calculation for the hub diameter

$$D_a \geq D \frac{\sigma_b + K_a \cdot P_h}{\sigma_b - K_a \cdot P_h}$$

D<sub>a</sub>—outside diameter of hub mm  
 D—inside diameter of hub mm  
 P<sub>h</sub>—surface pressures on hub Mpa  
 σ<sub>b</sub>—tensile strength of material  
 K<sub>a</sub>—It should be 0.6 for single CAPT lock, it will be 0.8 when two CAPT locks or more are installed together

4. Calculation for the inside diameter of cannon

$$d_B < d \sqrt{\frac{\sigma_b - 2 \times P_s \cdot K_3}{\sigma_b}}$$

d<sub>B</sub>—inside diameter of cannon mm  
 d—outside diameter of cannon mm  
 σ<sub>b</sub>—tensile strength of shaft material Mpa  
 P<sub>s</sub>—pressure on the surface of shaft Mpa  
 K<sub>3</sub>—coefficient=0.6

5. Settlement for the surface roughness and dimension tolerance

Fitting section	Ra(um) Surface roughness	Dimension precision
Shaft diameter d	1.6/√	h8–H9
Bore diameter D	1.6/√	H8–H9

6. Installation for CAPT-LOCKS

Cleaning the CAPT-LOCKS, then install it into corresponding position of hub and shaft(Ref Drawing A). Then acc. to the order in Drawing B. Tighten the bolts in turn, the bolts should be tightened step by step in 3 to 4 times up to specified rated torque. After correct installation, CAPT-LOCKS should be inspected radial and axial runout as per A ≤ 0.05mm, B ≤ 0.002Rmm.

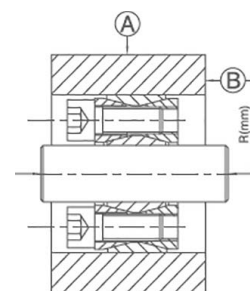
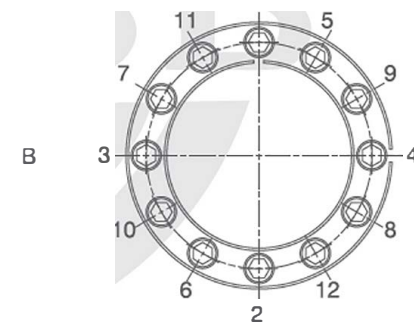
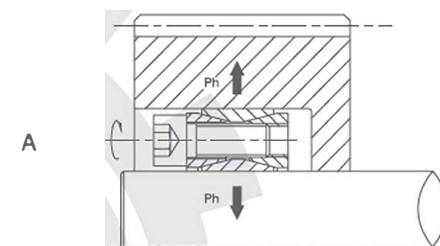

**7 Disassembling CAPT-LOCKS**

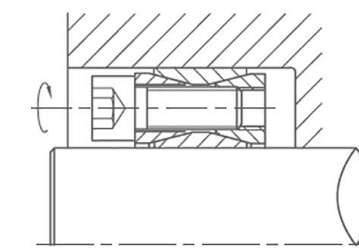

Loose and remove the tightening bolts

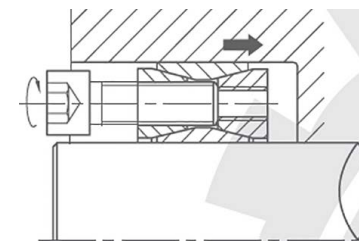

Put bolts into the corresponding threaded jack holes, turning the bolts in clockwise, loose the inner taper rings.

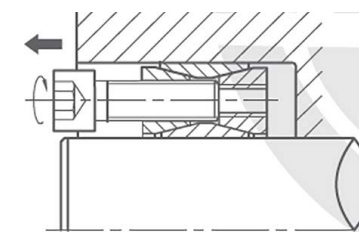

Pull out the bolts with strength, loose and remove outer taper rings

As for disassembling loose and remove all the tightening bolts first, then place the unloading bolts in the corresponding unloading tap holes (ie, tap holes with bolts zinc plated),and tighten them in turn, taper rings on the both sides of CAPT lock can be gradually seperated. By doing so, the inner and outer rings will counter spring out from the bore of hub and surface of shaft. Then the CAPT lock can be disassembled.

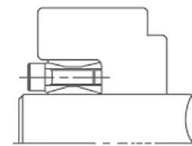

Conventional installation, for the usage of ordinary situation and general power transmission.

---

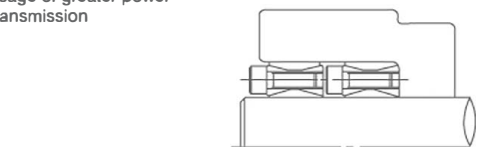

Used in pairs, for the usage of greater power transmission

---

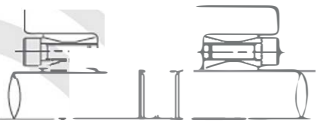

Mounted with shaft sleeves to connect transmission between two shafts. They have the same function with couplings.

---

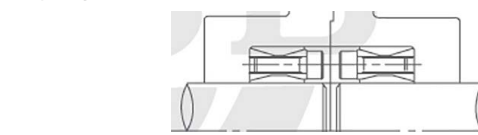

Mounted with the couplings to connect transmission between two shafts

---

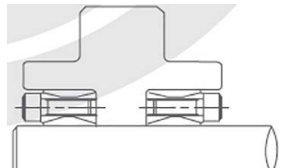

Installed from both sides, for the usage of greater power transmission

---



While installed with cams, the position and angel of the cams can be adjusted at will



# CAPT-LOCKS

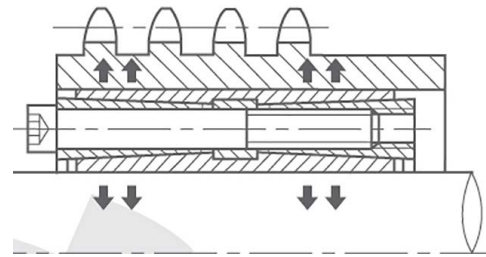

suit for shaft diameter  $\phi 45 \sim \phi 340$  (mm)

**D CAPT-Locks** is a heavier type of the **B CAPT-Lock** which has the connecting capacity of two or three times that of the **B** type. The dimension series of the **D** type is the same as the **B** type so you can simply use one piece of the **D** type and reduce costs.

**D CAPT-Locks** has characteristics of self installation and good concentricity. The guiding taper surface does not need to be machined specially. The central bore of the hub and the surface of the shaft all align which helps in cutting production time and money.

**D CAPT-Locks** have the characteristics of easy on and easy off, high precision for installation and connection capacity. The connecting function of **D CAPT-Locks** comes from the friction and pressure between the **CAPT-Locks** and the shaft and hub. It connects without slot and key. This eliminates the need for machining the keyway, pressing installation, and hot charging. **D** type can be used with heavy duty and larger torque transmissions.

Nomenclature for CAPT-LOCKS type D

**CL 200 X 260 D**

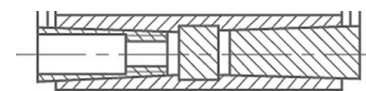
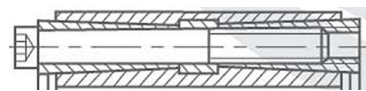
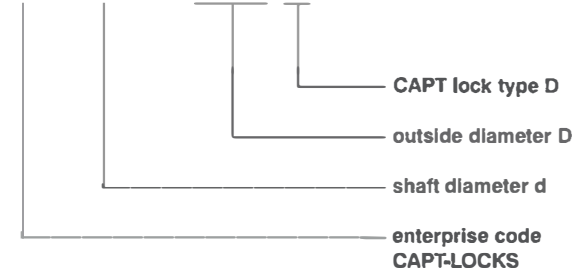

**D** CAPT-LOCKS



# CAPT-LOCKS

**D**

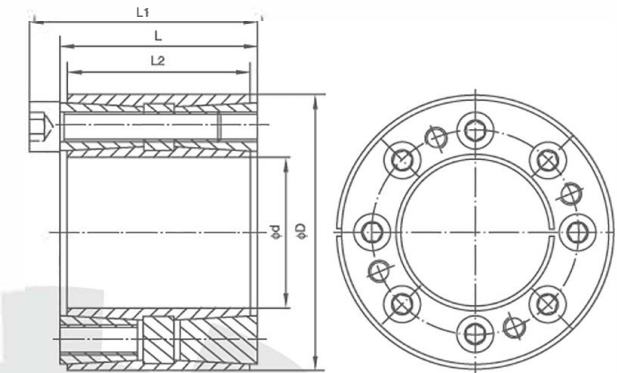

## D CAPT-LOCKS

Catalog	Fundamental dimensions			SizesxN	Rated load		Ps Mpa	Ph Mpa	Ma N.m	G Kg
	L2	L	L1		Ft(Kn)	Mt(Kn.m)				
CL45x75D	56	64	72	M8x9	160	3.51	179	108	41	1.25
CL48x80D	56	64	72	M8x9	160	3.72	168	101	41	1.41
CL50x80D	56	64	72	M8x9	170	4.3	162	101	41	1.35
CL55x85D	56	64	72	M8x9	170	4.7	147	95	41	1.45
CL60x90D	56	64	72	M8x11	190	5.81	165	110	41	1.55
CL65x95D	56	64	72	M8x11	190	6.10	130	89	41	1.92
CL70x110D	70	78	88	M10x11	330	11.8	179	114	83	3.11
CL75x115D	70	78	88	M10x11	330	12.6	167	109	83	3.28
CL80x120D	70	78	88	M10x12	360	14.7	171	114	83	3.45
CL85x125D	70	78	88	M10x12	360	15.6	161	109	83	3.63
CL90x130D	70	78	88	M10x13	390	17.9	165	114	83	3.8
CL95x135D	70	78	88	M10x13	390	18.9	156	110	83	3.97
CL100x145D	90	100	112	M12x12	467	23.3	181	108	145	6.80
CL110x155D	90	100	112	M12x13	553	30.4	190	110	145	7.50
CL120x165D	90	100	112	M12x15	617	37	195	119	145	8.60
CL130x180D	104	116	130	M14x13	759	49	180	111	230	11.1
CL140x190D	104	116	130	M14x15	843	59	186	121	230	11.8
CL150x200D	104	116	130	M14x16	897	67	185	123	230	12.6
CL160x210D	104	116	130	M14x17	950	76	183	123	230	13.4
CL170x225D	134	146	162	M16x15	1223	104	172	110	355	19.6
CL180x235D	134	146	162	M16x16	1289	116	172	113	355	20.6
CL190x250D	134	146	162	M16x17	1363	130	172	113	355	23.8
CL200x260D	134	146	162	M16x17	1368	136	172	108	355	24.9
CL220x285D	134	146	162	M16x20	1582	174	172	118	355	29.6
CL240x305D	134	146	162	M16x22	1725	207	172	120	355	31.9
CL260x325D	134	146	162	M16x22	1800	225	170	110	355	34.3
CL280x355D	165	177	197	M20x20	2429	340	168	118	690	52.0
CL300x375D	165	177	197	M20x22	2540	381	161	112	690	55.3
CL320x405D	165	177	197	M20x22	2781	431	175	122	690	67.3
CL340x425D	165	177	197	M20x24	2994	509	171	108	690	71.0

The items <CL200X260D are standard products in stock, the items >CL200X260D will be produced against orders



# CAPT-LOCKS

## D CAPT-Locks Assembling diagram

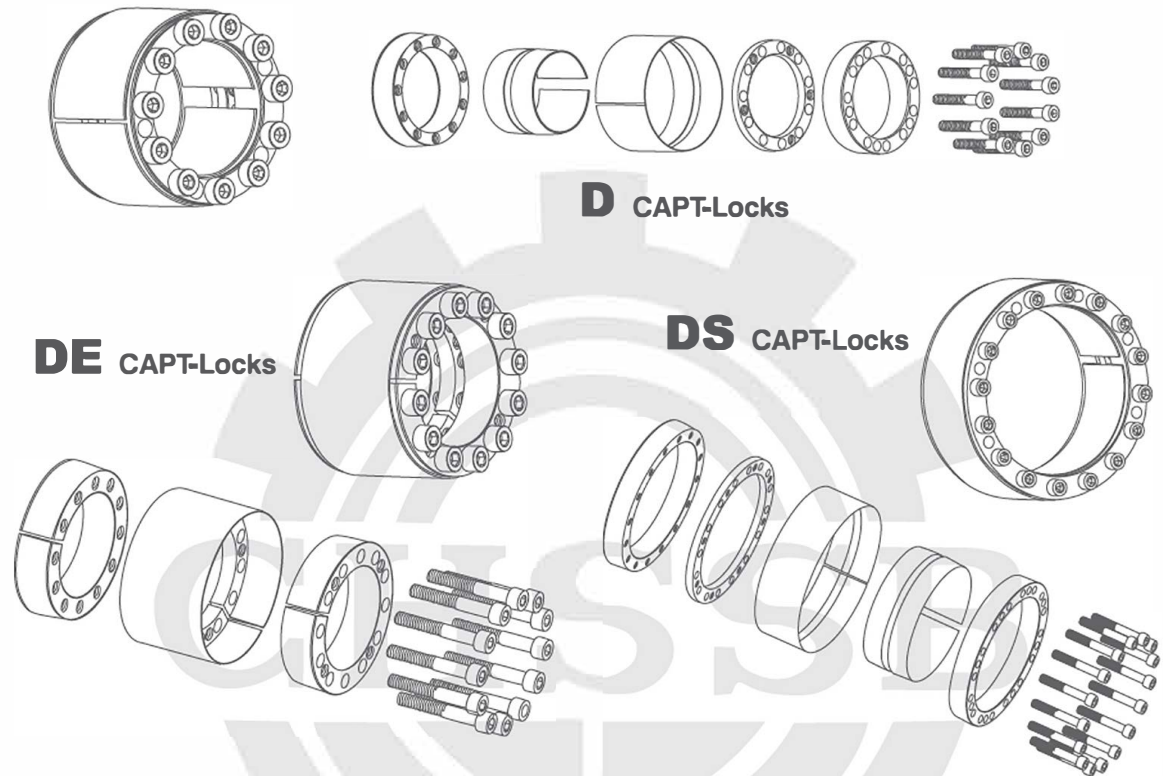

### Attention for the usage of CAPT-LOCKS

<p>200°C      -30°C</p> <p>1. Temperature of the work environment for the CAPT-Locks is from -30 C to 200 C, otherwise the CAPT-Locks will not work efficiently.</p>	<p>N.M</p> <p>3. CAPT-Locks can be assemble and reassembled repeatedly. But after the repeated installation and disassembling, the shape of the CAPT-Locks can alter slightly which will reduce the amount of torque.</p>
<p>2. When the CAPT-Locks are used in the open or in a place of high humidity and moisture, it should be protected from rust.</p>	<p>KEYWAY -10%</p> <p>4. If the CAPT-Locks are installed with the shaft with keyway, the rated torque will be reduced by roughly 10%.</p>



## Key elements for designing and calculation D/DS

1. Determine max torque and max axial load

$$M_{max} = \frac{30000H}{\pi \cdot n} \cdot K \text{ (N m)}$$

$$F_{max} = F \cdot K$$

H--Transmission power KW  
n--rotational speed r/min  
K--coefficient needed  
Used coefficient sheet for K

Sheet for coefficient used K

No shock load, transmitting with little inertia	1.5-2.5
Slight shock load, transmitting with middle inertia	2.0-4.0
Big shock load, transmitting with heavy inertia	3.0-5.0

2. Calculate synthetic load and transmitted torque

$$M_h = \sqrt{M_{max}^2 + \left(\frac{d}{2} \times F_{max}\right)^2}$$

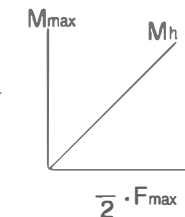

M<sub>max</sub>—Required transmit torque Nm  
F<sub>max</sub>—Required transmit axial force N  
M<sub>h</sub>— synthetic transmit torque Nm  
d—Transmission shaft diameter mm  
M<sub>t</sub>—CAPT lock rated transmitted torque Nm

M<sub>t</sub> ≥ M<sub>h</sub> can be used.  
M<sub>t</sub> < M<sub>h</sub> need bigger type of CAPT lock or to be install by two CAPT locks or more together

3. Calculation for the hub diameter

$$D_a \geq D \frac{\sigma_b + K_a \cdot P_h}{\sigma_b - K_a \cdot P_h}$$

D<sub>a</sub>—outside diameter of hub mm  
D—inside diameter of hub mm  
P<sub>h</sub>—surface pressures on hub Mpa  
σ<sub>b</sub>—tensile strength of material  
K<sub>a</sub>—It should be 0.6 for single CAPT lock, it will be 0.8 when two CAPT locks or more are installed together

4. Calculation for the inside diameter of cannon

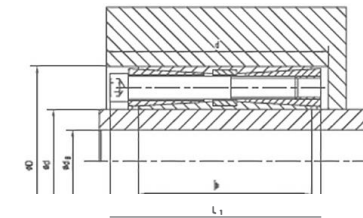

$$d_b \leq d \sqrt{\frac{\sigma_b - 2 \times P_s \cdot K_3}{\sigma_b}}$$

d<sub>b</sub>—inside diameter of cannon mm  
d—outside diameter of cannon mm  
σ<sub>b</sub>—tensile strength of shaft material Mpa  
P<sub>s</sub>—pressure on the surface of shaft Mpa  
K<sub>3</sub>—coefficient=0.6

5. Settlement for the surface roughness and dimension tolerance

Cleaning the CAPT-LOCKS, then install it into corresponding position of hub and shaft (Ref Drawing A). Then acc. to the order in Drawing B. Tighten the bolts in turn, the bolts should be tightened step by step in 3 to 4 times up to specified rated torque. After correct installation, CAPT-LOCKS should be inspected radial and axial runout as per A ≤ 0.05mm, B ≤ 0.002Rmm.

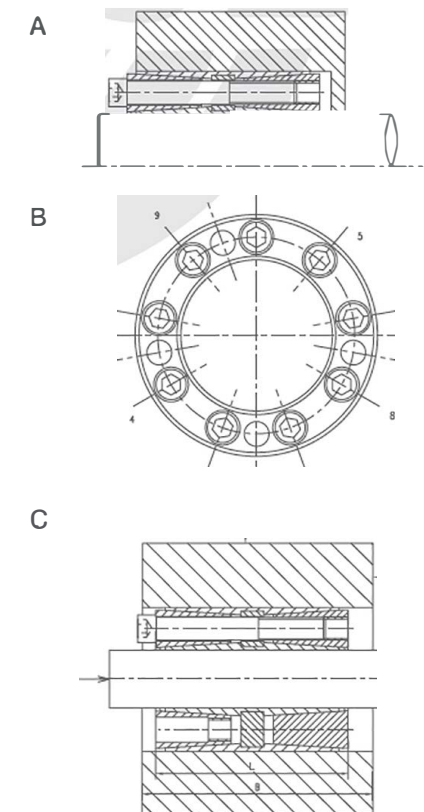



6. Determine the surface roughness and dimension tolerance

Fitting section	surface roughness	Dimension precision
shaft diameter d	1.6/	h8
bore diameter D	1.6/	H8

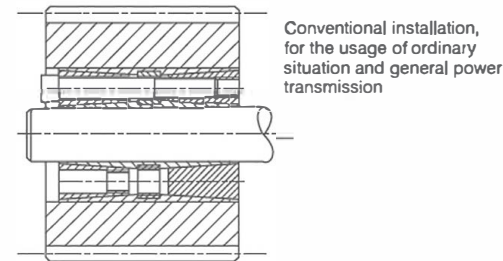

7. Disassembling for CAPT locks

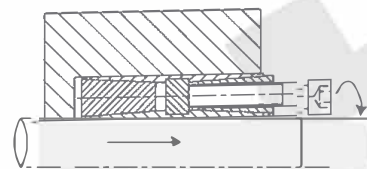

1. Loose and remove all the tightening bolts first, then place the unloading bolts in the corresponding unloading tap hole of the tightening taper ring in A side, tightening and pressing in proper order, separate the tightening taper ring in A side with the inside and outside taper bushes step by step.

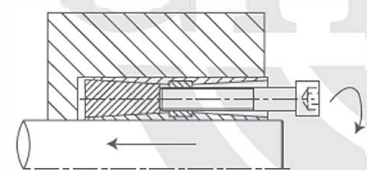

2. After removing the tight taper ring in A side, place the unloading bolts in the corresponding unloading tap hole in the middle ring, tightening and press in proper order, separate the tightening taper ring in B side with the inside and outside taper bushes step by step from the other side.  
D type CAPT LOCK can be easily disassembled after the above two steps.

Used in pairs, Suitable for the usage of greater power transmission

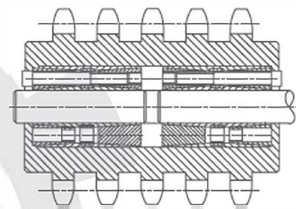

Mounted with shaft sleeves to connect transmission between two shafts. They have the same function with couplings

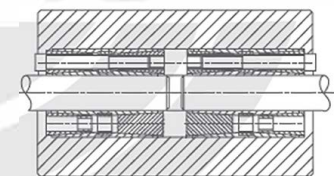

While installed with cams, the position and angle of the cams can be adjusted at will

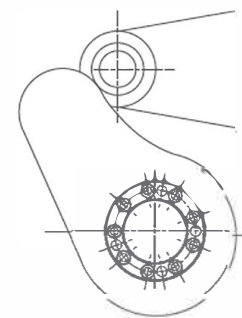

# CAPT-LOCKS

# FA2

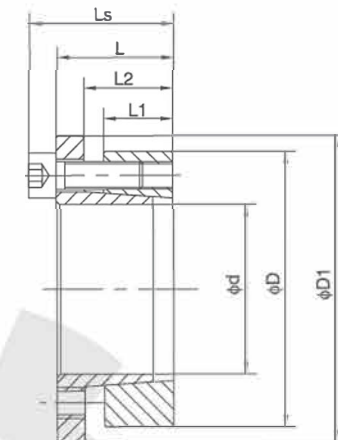

## FA2 CAPT-LOCKS

Table:1

Catalog	Fundamental dimensions					SizesxN	Rated load		Ps	Ph	Ma	G
	L1	L2	L	Ls	D1		Ft(Kn)	Mt(Kn.m)				
CL18x47FA2	17	22	28	34	56	M6x5	28	0.25	241	95	17	0.26
CL19x47FA2	17	22	28	34	56	M6x5	28	0.26	229	95	17	0.27
CL20x47FA2	17	22	28	34	56	M6x5	28	0.28	220	95	17	0.27
CL22x47FA2	17	22	28	34	56	M6x5	28	0.30	200	95	17	0.28
CL24x50FA2	17	22	28	34	59	M6x5	28	0.33	180	90	17	0.29
CL25x50FA2	17	22	28	34	59	M6x6	34	0.42	210	105	17	0.29
CL28x55FA2	17	22	28	34	64	M6x6	34	0.47	190	95	17	0.35
CL30x55FA2	17	22	28	34	64	M6x6	34	0.50	175	95	17	0.40
CL32x60FA2	17	22	28	34	69	M6x8	45	0.72	220	115	17	0.44
CL35x60FA2	17	22	28	34	69	M6x8	45	0.79	200	115	17	0.48
CL38x65FA2	17	22	28	34	74	M6x8	45	0.85	185	105	17	0.48
CL40x65FA2	17	22	28	34	74	M6x8	45	0.90	175	105	17	0.55
CL42x75FA2	20	25	33	41	84	M8x7	73	1.49	225	125	41	0.76
CL45x75FA2	20	25	33	41	84	M8x7	73	1.60	215	125	41	0.80
CL48x80FA2	20	25	33	41	89	M8x7	73	1.71	200	120	41	0.81
CL50x80FA2	20	25	33	41	89	M8x7	73	1.79	195	120	41	0.87
CL55x85FA2	20	25	33	41	94	M8x8	83	2.10	200	130	41	0.96
CL60x90FA2	20	25	33	41	99	M8x8	83	2.32	185	125	41	1.00
CL63x95FA2	20	25	33	41	104	M8x9	94	2.51	188	130	41	1.06
CL65x95FA2	20	25	33	41	104	M8x9	94	2.98	190	130	41	1.70
CL70x110FA2	24	30	40	50	119	M10x8	133	4.63	210	135	83	1.79
CL75x115FA2	24	30	40	50	124	M10x8	133	5.00	195	125	83	1.95
CL80x120FA2	24	30	40	50	129	M10x8	133	5.30	185	125	83	1.98
CL85x125FA2	24	30	40	50	134	M10x9	148	6.30	195	135	83	2.20
CL90x130FA2	24	30	40	50	139	M10x9	148	6.75	185	130	83	2.28
CL95x135FA2	24	30	40	50	144	M10x10	166	7.90	195	135	83	3.20
CL100x145FA2	26	32	44	56	154	M12x8	194	9.70	200	140	145	3.40
CL110x155FA2	26	32	44	56	164	M12x8	194	10.6	180	130	145	3.65
CL120x165FA2	26	32	44	56	174	M12x9	216	13.0	185	135	145	5.25
CL130x180FA2	34	40	54	68	189	M12x12	290	18.9	175	125	145	5.63

Note: All the items listed above are for the standard parts in stock

# CAPT-LOCKS

# FA2

## FA2 CAPT-LOCKS®

Table:2

Catalog dxD	Fundamental dimensions					SizesxN	Rated load		Ps Mpa	Ph Mpa	Ma N,m	G Kg
	L1	L2	L	Ls	D1		Ft(Kn)	Mt(Kn,m)				
CL140x190FA2	34	40	54	68	199	M14x9	290	20.5	165	120	230	5.95
CL150x200FA2	34	40	54	68	209	M14x10	333	24.5	175	130	230	6.89
CL160x210FA2	34	40	54	68	219	M14x11	362	28.9	180	135	230	7.85
CL170x225FA2	44	50	64	78	234	M14x12	400	33.2	140	105	230	8.32
CL180x235FA2	44	50	64	78	244	M14x12	400	35.6	135	105	230	9.12
CL190x250FA2	44	50	64	78	259	M14x15	500	46.5	160	120	230	9.58
CL200x260FA2	44	50	64	78	269	M14x15	500	48.3	150	115	230	11.7
CL220x285FA2	50	56	72	88	294	M16x12	578	58.0	145	110	355	15.9
CL240x305FA2	50	56	72	88	314	M16x15	725	79.0	165	130	355	16.5
CL260x325FA2	50	56	72	88	334	M16x18	830	102	180	145	355	17.7
CL280x355FA2	60	66	84	102	364	M18x16	925	118	150	120	485	24.0
CL300x375FA2	60	66	84	102	384	M18x18	1050	142	160	125	485	25.5
CL320x405FA2	74	81	101	121	414	M20x18	1365	198	150	120	690	38.0
CL340x425FA2	74	81	101	121	434	M20x21	1590	230	175	135	690	40.0
CL360x455FA2	86	94	116	138	464	M22x18	1675	256	140	110	930	48.0
CL380x475FA2	86	94	116	138	484	M22x21	1980	310	155	125	930	57.0
CL400x495FA2	86	94	116	138	504	M22x21	1980	352	150	120	930	63.0

Note: All the items listed in the above table will be produced against orders

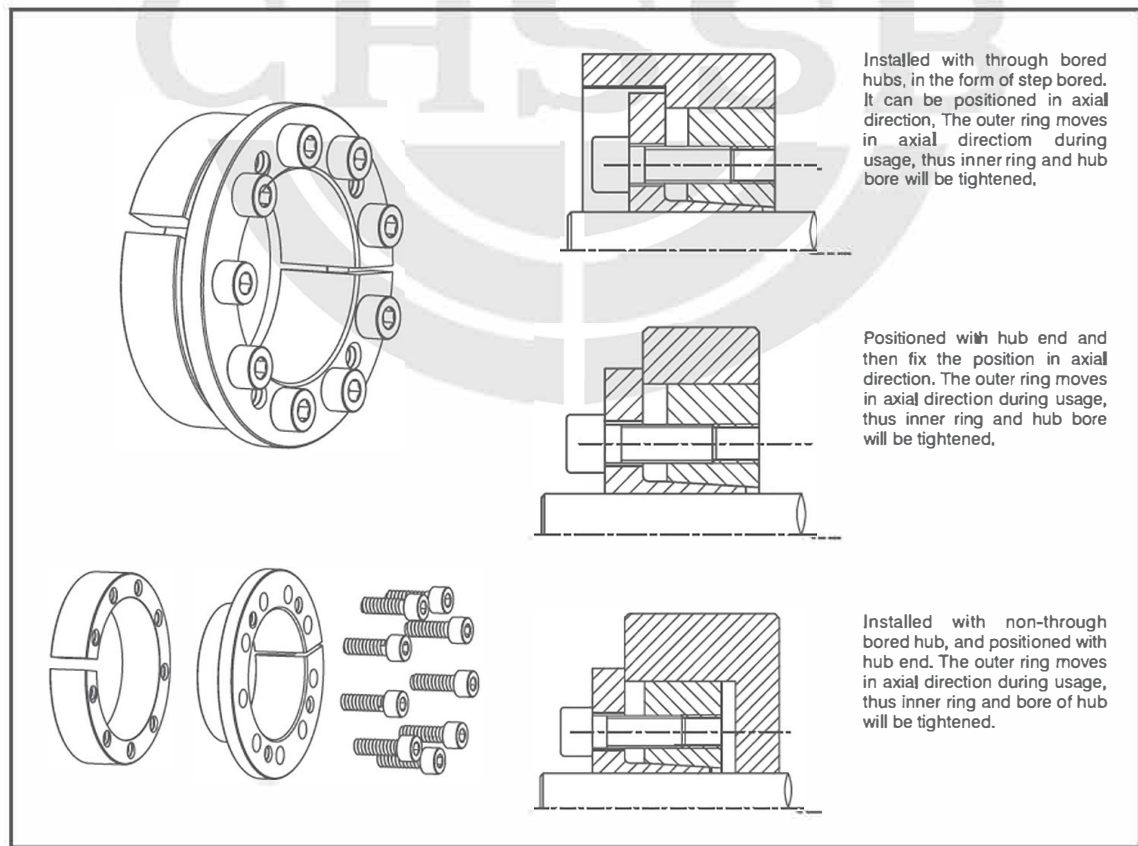

# CAPT-LOCKS Comparisons

CAPT LOCKS	TOLLOK	FENLOCK	SATI	KTR	RINGBLOCK	TSUBAKI
B	TUK200	FLK200	KLGG	K100	R1120	AS
BH	TUK400		KLHH		R1000	AD
D	TUK401					
DS						
DE			KLEE	K400		
DX	TUK450				R1800	
FAR	TUK350					
E	TUK300	FLK300	KLNN	K105	R1060	EL
T	TUK110	FLK110	KLCC	K150	R1100	TF
FA1	TUK132	FLK132		K250	R1710	
FA2	TUK133	FLK133		K203	R1720	
FBI	TUK130		KLAA	K206	R1301	
FBI	TUK130		KLAB	K200	R1302	
FBI	TUK131		KLDA	K201		
FC			KLDB			
FD						AE
FE	TUK134		KLBB	K225	R1500	
HL	TUK250				R1500	
HLL	TUK250L				R1500	
ML						ML
ML-B						ML
C		FLK603				
SD	TUK603		KLPP	K603	R2200	SL
SS	TUK622				R1600	
SK	TUK500					

Dimensionally and mechanically equivalent  
Basic dimensions are same, but the mechanical characteristics may have slight variations



## CAPT-LOCKS Stock Price List

Part Number	Description	B Series	D Series	FA2 Series
CL18x47	CAPT LOCK 18 ID 47 OD	\$28.44		
CL19x47	CAPT LOCK 19 ID 47 OD	\$28.44		
CL20x47	CAPT LOCK 20 ID 47 OD	\$28.44		
CL22x47	CAPT LOCK 22 ID 47 OD	\$28.44		
CL24x50	CAPT LOCK 24 ID 50 OD	\$30.75		
CL25x50	CAPT LOCK 25 ID 50 OD	\$30.75	\$80.44	\$33.69
CL28x55	CAPT LOCK 28 ID 55 OD	\$34.25	\$80.44	\$33.97
CL30x55	CAPT LOCK 30 ID 55 OD	\$33.19	\$80.44	\$35.50
CL32x80	CAPT LOCK 32 ID 80 OD	\$35.50		
CL35x80	CAPT LOCK 35 ID 80 OD	\$35.50	\$84.56	
CL38x85	CAPT LOCK 38 ID 85 OD	\$38.94	\$84.56	
CL40x85	CAPT LOCK 40 ID 85 OD	\$38.94	\$84.56	
CL42x75	CAPT LOCK 42 ID 75 OD	\$47.25	\$90.06	
CL45x75	CAPT LOCK 45 ID 75 OD	\$47.25	\$90.06	
CL48x80	CAPT LOCK 48 ID 80 OD	\$50.75	\$96.38	
CL50x80	CAPT LOCK 50 ID 80 OD	\$49.69	\$96.38	
CL55x85	CAPT LOCK 55 ID 85 OD	\$55.44	\$102.63	
CL60x90	CAPT LOCK 60 ID 90 OD	\$57.81	\$117.88	
CL65x95	CAPT LOCK 65 ID 95 OD	\$63.25	\$128.94	
CL70x110	CAPT LOCK 70 ID 110 OD	\$87.75	\$187.19	
CL75x115	CAPT LOCK 75 ID 115 OD	\$96.19	\$202.44	
CL80x120	CAPT LOCK 80 ID 120 OD	\$102.00	\$221.81	
CL85x125	CAPT LOCK 85 ID 125 OD	\$108.19	\$230.81	
CL90x130	CAPT LOCK 90 ID 130 OD	\$115.75	\$239.94	
CL95x135	CAPT LOCK 95 ID 135 OD	\$129.88	\$250.94	
CL100x145	CAPT LOCK 100 ID 145 OD	\$144.63	\$341.06	\$243.88
CL105x150	CAPT LOCK 105 ID 150 OD	\$152.19		
CL110x155	CAPT LOCK 110 ID 155 OD	\$157.31	\$367.44	
CL115x180	CAPT LOCK 115 ID 180 OD	\$169.88		
CL120x165	CAPT LOCK 120 ID 165 OD	\$178.94	\$413.19	\$291.81
CL125x170	CAPT LOCK 125 ID 170 OD	\$208.63		
CL130x180	CAPT LOCK 130 ID 180 OD	\$223.00	\$536.56	\$337.00
CL140x190	CAPT LOCK 140 ID 190 OD	\$247.31	\$623.94	
CL150x200	CAPT LOCK 150 ID 200 OD	\$278.38	\$728.00	\$413.47
CL160x210	CAPT LOCK 160 ID 210 OD	\$293.19	\$765.38	
CL170x225	CAPT LOCK 170 ID 225 OD	\$365.88	\$980.25	
CL180x235	CAPT LOCK 180 ID 235 OD	\$385.19	\$1,106.50	
CL190x250	CAPT LOCK 190 ID 250 OD	\$497.25	\$1,213.25	
CL200x260	CAPT LOCK 200 ID 260 OD	\$528.75	\$1,278.44	



Part Number	Description	B Series	D Series	FA2 Series
CL210X275	CAPT LOCK B210 ID 275 OD	\$582.75		
CL220X285	CAPT LOCK 220 ID 285 OD	\$638.13	\$1,455.88	\$927.28
CL240X305	CAPT LOCK 240 ID 305 OD	\$748.44	\$1,566.81	\$1,133.75
CL250X315	CAPT LOCK 250 ID 315 OD	\$788.56		
CL260X325	CAPT LOCK 260 ID 325 OD	\$839.25	\$2,157.44	
CL280X355	CAPT LOCK 280 ID 355 OD	\$1,209.38	\$2,677.44	
CL300X375	CAPT LOCK 300 ID 375 OD	\$1,311.81	\$2,890.94	
CL320X405	CAPT LOCK 320 ID 405 OD	\$1,779.75	\$3,466.38	
CL340X425	CAPT LOCK 340 ID 425 OD	\$1,889.31	\$4,007.13	
CL360X455	CAPT LOCK 360 ID 455 OD	\$2,635.44		
CL380X475	CAPT LOCK 380 ID 475 OD	\$2,908.88		
CL400X495	CAPT LOCK 400 ID 495 OD	\$3,024.38		

All prices are net excluding GST



# Specialised Products

Chain and Drives offer complete design of power transmission components to suit your individual requirements. Our design team will assist you through concept design to construction drawings, we will then have your product manufactured to your specifications.

Our scope includes Sprockets, Chain Assemblies, Couplings, Pulleys, Gearboxes, Motors, Drives & Controls, and Conveyor Components.

## Our Products Include:



GEARBOXES



MOTORS & BRAKES

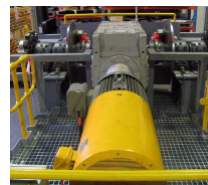

DRIVE ASSEMBLIES



DRIVES & CONTROLS



COUPLINGS



CHAIN & SPROCKETS



BELTS & PULLEYS



BEARINGS



SEALS



SERVICE CENTRE  
SITE SERVICES  
TOOLS & TRAINING



SPECIALISED  
PRODUCTS



CLUTCHES

SALES AND ENGINEERING  
Unit 1, 45 Inspiration Drive  
Wangara WA 6065

WORKSHOP AND DISTRIBUTION  
22 Beneficial Way  
Wangara WA 6065

SALES AND ENGINEERING NSW  
Unit 7 & 8, 4 Abbott Road  
Seven Hills NSW 2147  
T +61 2 9674 8611 F +61 2 9674 8363

PO Box 1343, Wangara WA 6947  
P +61 8 9303 4966 F +61 8 9303 4977  
[info@chainanddrives.com.au](mailto:info@chainanddrives.com.au)