



DAIDO KOGYO CO., LTD.

New!

DID 60LB Pin Oven Chain



Daido's Pin Oven Chain, also referred to as Deco chain, is a quality product that is primarily used to convey decorated and base coated cans through high speed & high heat ovens. Sizes, prices, and pin tip varieties are available upon request.

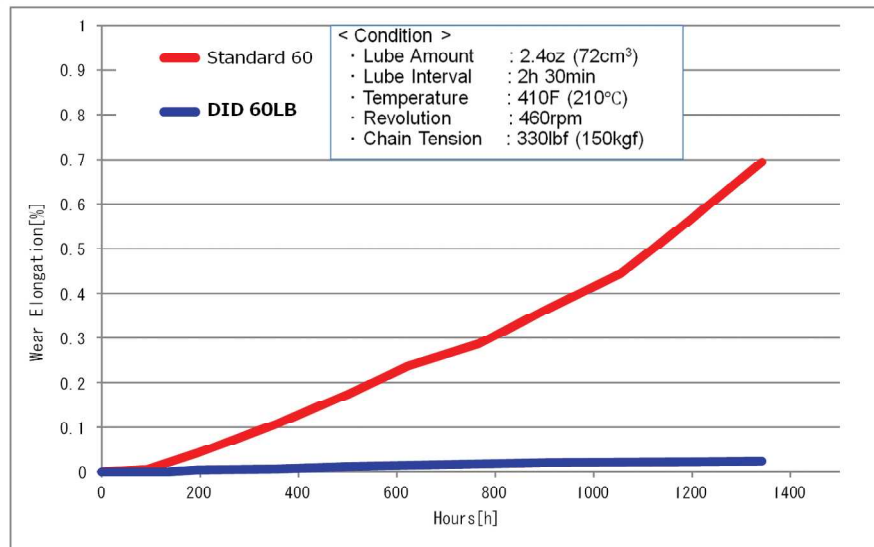
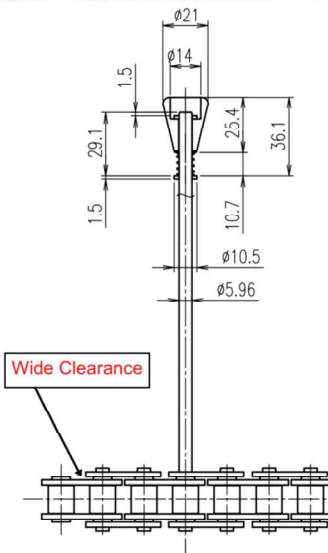

* Benefits:

Wide Clearance

Wide clearance between outer and inner plates allows for chain lubrication to penetrate into the pin and bushing efficiently, preventing chain stretch.

Chain Lube Reduction

Reduction of chain lubrication, due to the efficient and smooth penetration, results in less contamination (sludge/fume) over the chain and can.

Polished Plates

Both the outer & inner plates have a polished finish, or smooth surface, allowing for easy cleaning.

Stable Long Pin

Bearing area between the pin and bushing is larger compared to standard chain, resulting in the long pin being more stable with less vibration.

Replacement Long Pins

The spring clip style connecting link with long pin & peek tip are available for replacement.

DID 60LB Pin Oven Chain

New!

* Features:

- * DID 60LB Pin Oven Chain
- * **Wide Clearance**
- * Spring Loaded Peek Tip
- * Carbon Steel with **Polished Finish**
(Both Outer & Inner Plates)

* Performance:

- 1). Tensile Strength: 32.4kN Min
- 2). Assembly of chain: 504LZ x PCS
- 3). Non-Riveted Pin= Easy Pin Replacement
- 4). Extended Bushing = Clearance Fit
- 5). Long Pin Projection:
To Be Determined By Customer

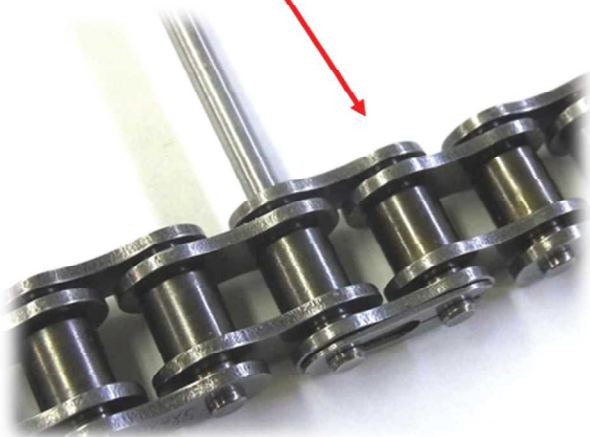

Non-riveted pin type LP can be easily replaced if it gets fractured or damaged.

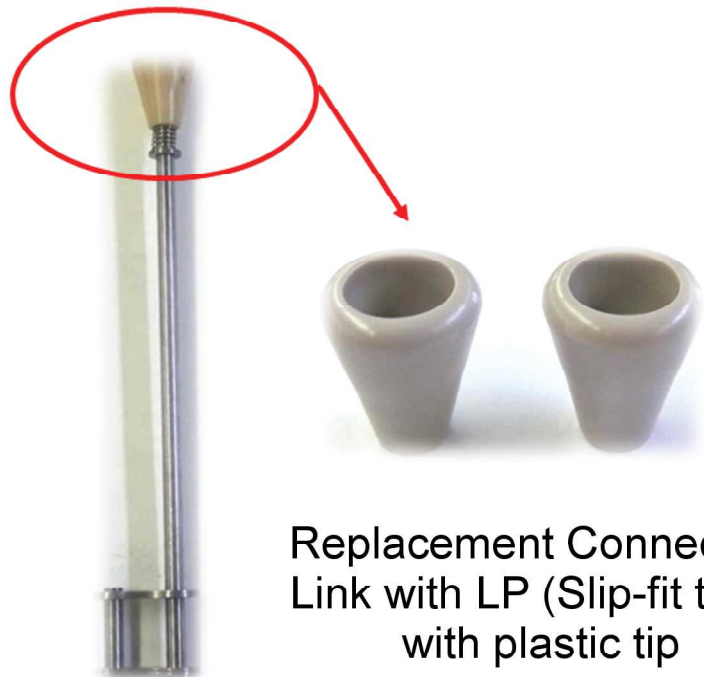

Replacement Connecting Link with LP (Slip-fit type) with plastic tip



DAIDO KOGYO CO., LTD.

Overseas Sales Div.
Industrial Products Engineering & Sales Department
3-5-4 Nihombashi Ningyo-Cho
Chuo-ku, Tokyo 103-0013, Japan
Phone: +81-3-3808-0780, Fax: +81-3-5695-8122
Website: www.did-coltd.com/english

Distributed By: