

ALBERI E SUPPORTI ALBERO

SHAFTS AND SHAFT SUPPORTS

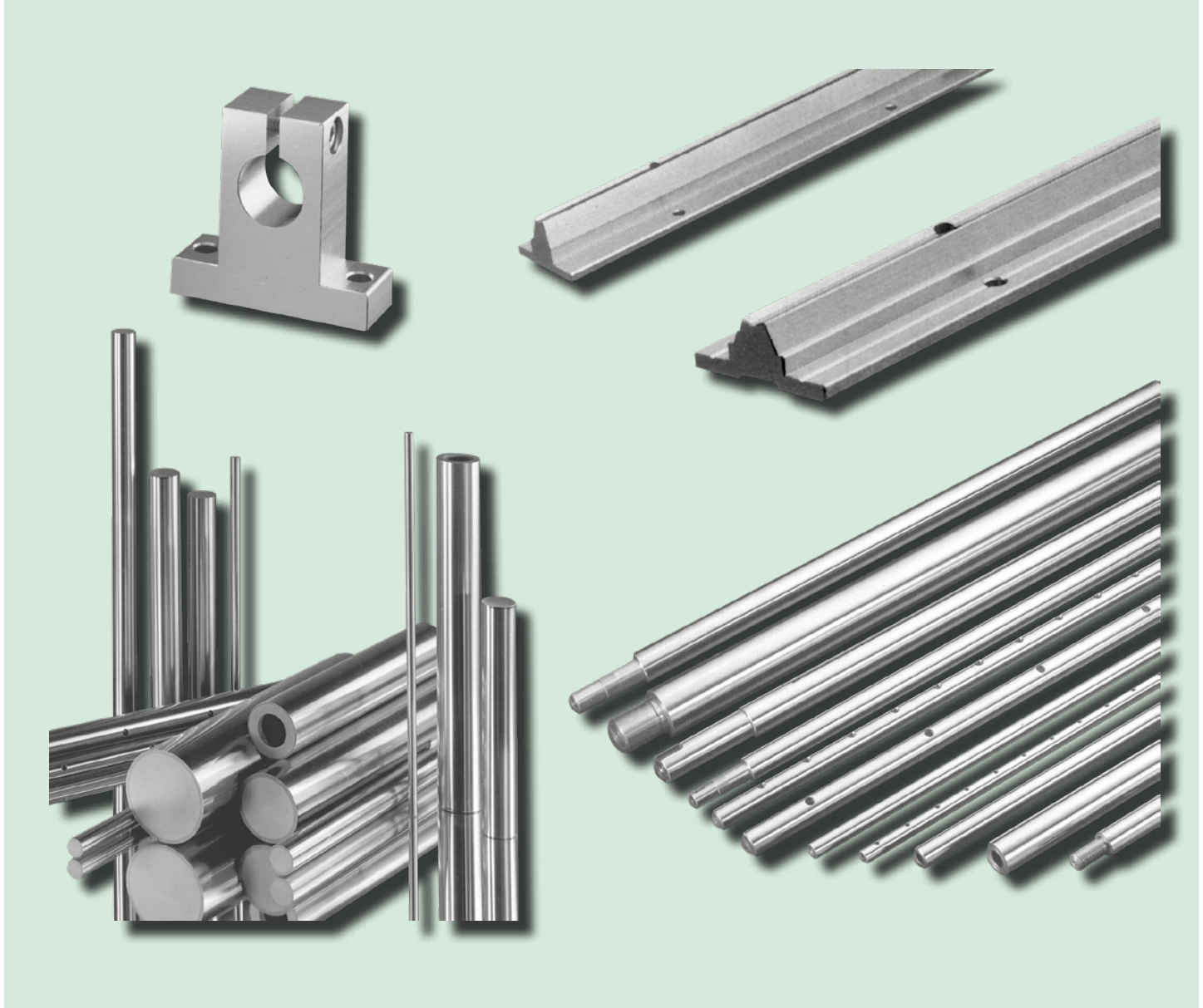

1. ALBERI DI PRECISIONE

1. PRECISION SHAFTS

Tipologie · Materiali impiegati · Principali caratteristiche · *Types · Materials · Main Features · Machinings*
Lavorazioni

SIGLA CODE	W	WV	WRA	WRB	WH	WZ	BAC
TIPOLOGIA <i>TYPE</i>	TEMPRATO RETTIFICATO <i>HARDENED & GROUND</i>	TEMPRATO CROMATO <i>CHROME PLATED & HARDENED</i>	INOX X90 <i>STAINLESS X90</i>	INOX X46 <i>STAINLESS X46</i>	TUBI TUBE	TUBI IN POLLICI <i>INCH DIMENSION TUBE</i>	CROMATO <i>CHROME PLATED</i>
MATERIALI <i>MATERIALS</i>	Cf53	Cf53	X90 CrMoV18	X46 Cr13	100Cr6	Cf53	C45
TOLLERANZE <i>TOLERANCES</i>	h6	h6	h6	h6	h6	h6	f7(h7)
DUREZZE <i>HARDNESS</i>	HRC62+/-2	CROMO HV 800-1000	HRC57+/-2	HRC55+/-2	HRC62+/-2	HRC62+/-2	HV 800-1000
DIAMETRI FORNIBILI <i>DIMENSION RANGE</i>	Ø 5 ÷ 100 mm	Ø 5 ÷ 100 mm	Ø 5 ÷ 60 mm	Ø 5 ÷ 60 mm	A RICHIESTA <i>UPON REQUEST</i>	A RICHIESTA <i>UPON REQUEST</i>	Ø 3 ÷ 100 mm

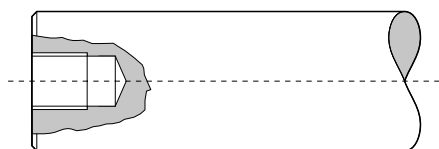

Foratura assiale
Axial Drilling

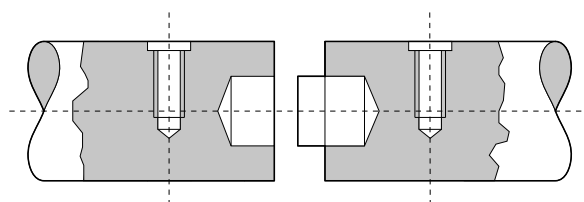

Giunzione di più alberi
Butt Joint

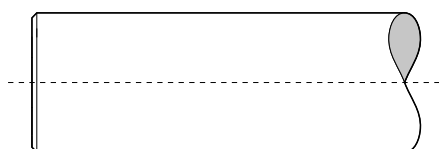

Taglio in lunghezza e sbavatura
Cut to length & chamfer

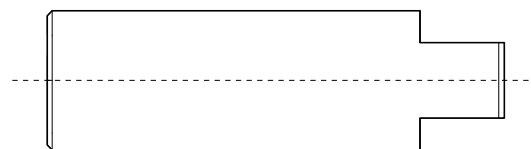

Piani fresati (a chiave)
Milling (flats for key)

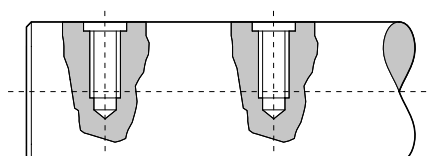

Foratura radiale
Radial drilling

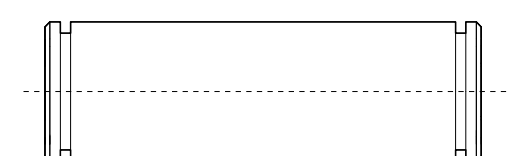

Sedi per anelli d'arresto
Snap ring groove

1.1. ALBERI DI SCORRIMENTO W

1.1. SHAFTS FOR LINEAR MOTION W

Acciaio C 50/Cf 53 · Temprato · Rettificato

C50/Cf53 Steel – Hardened & Ground

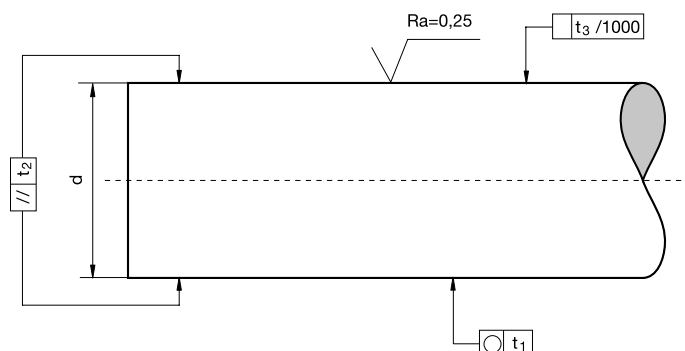

DIAMETRO ALBERO SHAFT DIAMETER mm	PESO WEIGHT Kg/m	DESCRIZIONE CODE	PROFONDITÀ DI TEMpra MAX MAX. HARDENING DEPTH DIN 6773 mm	TOLLERANZA STANDARD STANDARD TOLERANCE ISO H6 µm	ROTONDITÀ ROUNDNESS T1 µm	PARALLELISMO PARALLELISM T2 µm	LINEARITÀ STRAIGHTNESS T3 µm
5	0,15	W 5	0,8	0 - 8	4	6	300
6	0,22	W 6	0,8	0 - 8	4	6	300
8	0,39	W 8	1,0	0 - 9	4	6	300
10	0,61	W 10	1,0	0 - 9	4	6	300
12	0,89	W 12	1,3	0 - 11	5	8	200
14	1,21	W 14	1,3	0 - 11	5	8	200
15	1,37	W 15	1,3	0 - 11	5	8	200
16	1,57	W 16	1,6	0 - 11	5	8	200
18	1,98	W 18	1,6	0 - 11	5	8	200
20	2,45	W 20	1,6	0 - 13	6	9	100
24	3,55	W 24	1,8	0 - 13	6	9	100
25	3,83	W 25	1,8	0 - 13	6	9	100
30	5,51	W 30	2,0	0 - 13	6	9	100
32	6,30	W 32	2,0	0 - 16	7	11	100
35	7,55	W 35	2,5	0 - 16	7	11	100
40	9,80	W 40	2,5	0 - 16	7	11	100
50	15,3	W 50	3,0	0 - 16	7	11	100
60	22,1	W 60	3,0	0 - 19	8	13	100
70	30,2	W 70	3,0	0 - 19	8	13	100
80	39,2	W 80	3,0	0 - 19	8	13	100
90	49,9	W 90	3,0	0 - 22	10	16	100
100	61,7	W 100	3,3	0 - 22	10	16	100

1.2. ALBERI DI SCORRIMENTO WV

1.2. SHAFTS FOR LINEAR MOTION WV

Acciaio C 50/Cf 53 · Temprato · Rettificato e Cromato

C50/Cf53 Steel – Hardened, Chrome plated & Ground

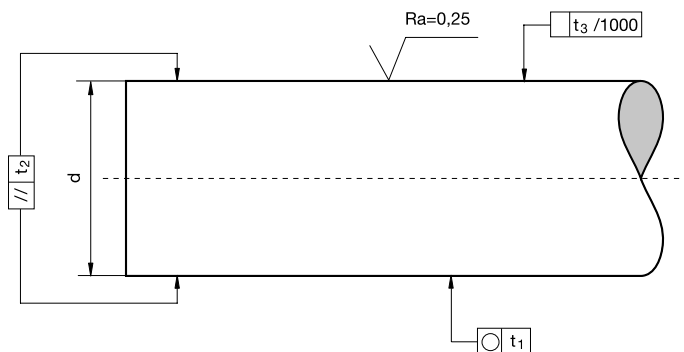

DIAMETRO ALBERO SHAFT DIAMETER mm	PESO WEIGHT Kg/m	DESCRIZIONE CODE	PROFONDITÀ DI TEMPRA MAX MAX. HARDENING DEPTH DIN 6773 mm	TOLLERANZA STANDARD STANDARD TOLERANCE ISO H6 µm	ROTONDITÀ ROUNDNESS T1 µm	PARALLELISMO PARALLELISM T2 µm	LINEARITÀ STRAIGHTNESS T3 µm
5	0,16	WV 5	0,8	0 - 12	6	10	300
6	0,23	WV 6	0,8	0 - 12	6	10	300
8	0,40	WV 8	1,0	0 - 15	6	10	300
10	0,62	WV 10	1,0	0 - 15	6	10	300
12	0,89	WV 12	1,3	0 - 18	8	12	200
14	1,21	WV 14	1,3	0 - 18	8	12	200
15	1,39	WV 15	1,3	0 - 18	8	12	200
16	1,58	WV 16	1,6	0 - 18	8	12	200
18	1,98	WV 18	1,6	0 - 18	8	12	200
20	2,47	WV 20	1,6	0 - 21	9	12	100
24	3,55	WV 24	1,8	0 - 21	9	12	100
25	3,85	WV 25	1,8	0 - 21	9	12	100
30	5,55	WV 30	2,0	0 - 21	9	12	100
32	6,30	WV 32	2,0	0 - 25	11	15	100
35	7,55	WV 35	2,5	0 - 25	11	15	100
40	9,87	WV 40	2,5	0 - 25	11	15	100
50	15,4	WV 50	3,0	0 - 25	11	15	100
60	22,2	WV 60	3,0	0 - 30	12	15	100
70	30,2	WV 70	3,0	0 - 30	12	15	100
80	39,5	WV 80	3,0	0 - 30	12	15	100
90	49,9	WV 90	3,0	0 - 35	14	17	100
100	61,7	WV 100	3,3	0 - 35	14	17	100

1.3. ALBERI DI SCORRIMENTO WRA-WRB

1.3. SHAFTS FOR LINEAR MOTION WRA/WRB

Acciaio X90 Cr Mo V18 - X46 Cr13

X90CrMoV18/X46Cr13 Stainless steel

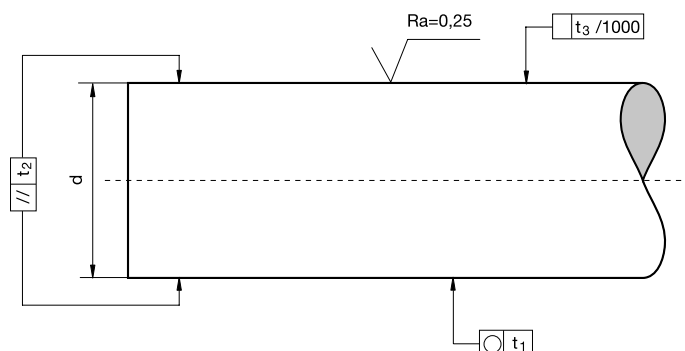

DIAMETRO ALBERO SHAFT DIAMETER mm	PESO WEIGHT Kg/m	DESCRIZIONE CODE	PROFONDITÀ DI TEMPRA MAX MAX. HARDENING DEPTH DIN 6773 mm	TOLLERANZA STANDARD STANDARD TOLERANCE ISO H6 µm	ROTONDITÀ ROUNDNESS T1 µm	PARALLELISMO PARALLELISM T2 µm	LINEARITÀ STRAIGHT- NESS T3 µm
5	0,15	WRA-WRB 5	0,7	0 - 8	4	5	300
6	0,22	WRA-WRB 6	0,7	0 - 8	4	6	300
8	0,40	WRA-WRB 8	0,8	0 - 9	4	6	300
10	0,62	WRA-WRB 10	1,1	0 - 9	4	6	300
12	0,89	WRA-WRB 12	1,3	0 - 11	5	8	200
14	1,21	WRA-WRB 14	1,5	0 - 11	5	8	200
15	1,39	WRA-WRB 15	1,6	0 - 11	5	8	200
16	1,58	WRA-WRB 16	1,6	0 - 11	5	8	200
20	2,47	WRA-WRB 20	1,8	0 - 13	6	9	100
25	3,85	WRA-WRB 25	2,0	0 - 13	6	9	100
30	5,55	WRA-WRB 30	2,4	0 - 13	6	9	100
40	9,87	WRA-WRB 40	2,6	0 - 16	7	11	100
50	15,41	WRA-WRB 50	2,9	0 - 16	7	11	100
60	22,2	WRA-WRB 60	3,0	0 - 19	8	13	100

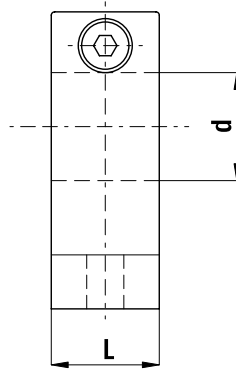
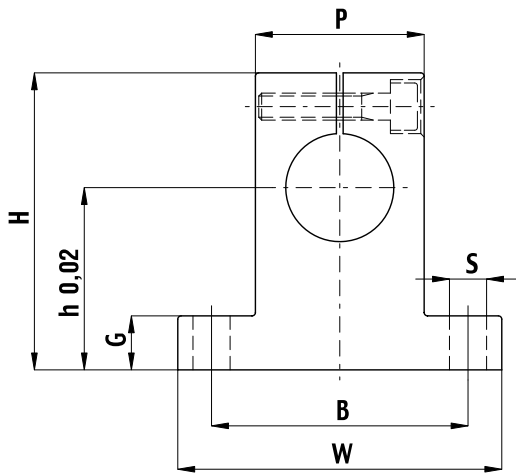
2. SUPPORTI PER ALBERI
2. SHAFTS SUPPORTS
SK

TIPOLOGIA TYPE	PESO WEIGHT [kg]	d [mm]	h [mm]	W [mm]	B [mm]	P [mm]	S [mm]	G [mm]	H [mm]	L [mm]	VITI DI MONTAGGIO MOUNTING BOLT
SK 08	0.024	8	20	42	32	18	5.5	6	32.8	14	M 5
SK 10	0.024	10	20	42	32	18	5.5	6	32.8	14	M 5
SK 12	0.030	12	23	42	32	20	5.5	6	37.5	14	M 5
SK 13	0.030	13	23	42	32	20	5.5	6	37.5	14	M 5
SK 16	0.040	16	27	48	38	25	5.5	8	44	16	M 5
SK 20	0.070	20	31	60	45	30	6.6	10	51	20	M 6
SK 25	0.130	25	35	70	56	38	6.6	12	60	24	M 6
SK 30	0.180	30	42	84	64	44	9	12	70	28	M 8
SK 35	0.270	35	50	98	74	50	11	15	85	32	M 10
SK 40	0.420	40	60	114	90	60	11	15	96	36	M 10
SK 50	0.750	50	70	126	100	74	14	18	120	40	M 12
SK 60	1.100	60	80	148	120	90	14	18	136	45	M 12

Sigla d'ordine: SK - d

Specification number: SK - d

SBR-L

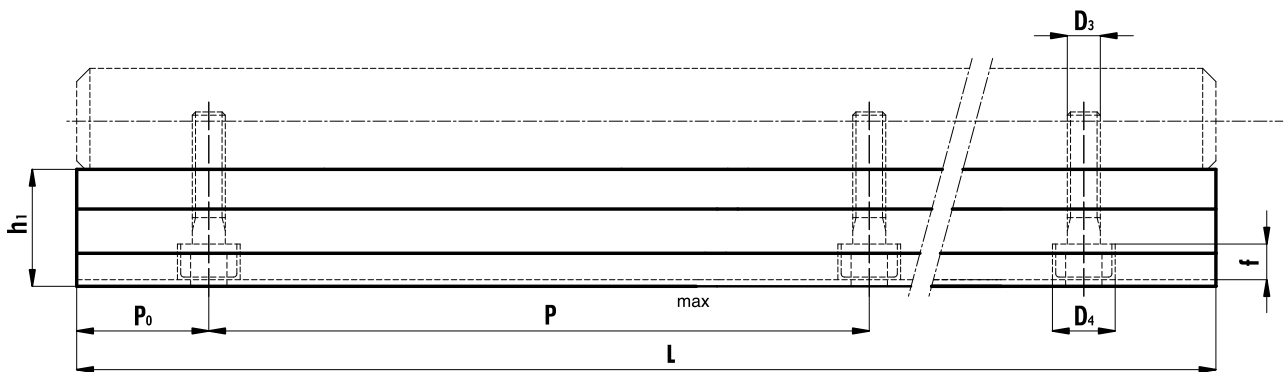
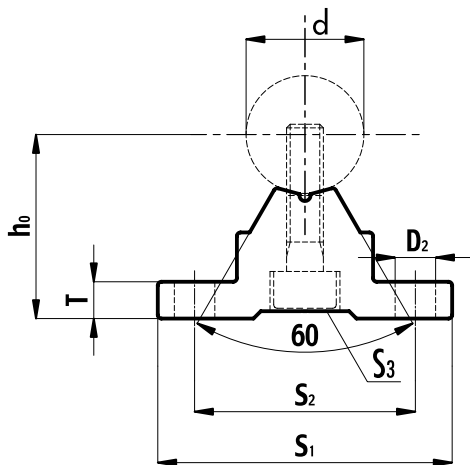

TIPOLOGIA TYPE	PESO WEIGHT [kg/m]	d [mm]	D ₂ [mm]	D ₃ [mm]	D ₄ [mm]	f [mm]	H ₀ [mm]	H ₁ [mm]	S ₁ [mm]	S ₂ [mm]	T [mm]	P [mm]	S ₃	L _{MAX}
SBR 16L	1.000	16	5.5	5.5	9.5	5.4	25	17.8	40	30	5	150	M 5	4000
SBR 20L	1.200	20	5.5	5.5	9.5	5.4	27	17.7	45	30	5	150	M 6	4000
SBR 25L	1.500	25	6.6	6.6	11	6.5	33	21	55	35	6	200	M 6	4000
SBR 30L	1.900	30	6.6	6.6	11	6.5	37	22.8	60	40	7	200	M 8	4000
SBR 35L	2.450	35	9	9	14	8.6	43	26.5	65	45	8	200	M 8	4000
SBR 40L	3.250	40	9	9	14	8.6	48	29.4	75	55	9	200	M 8	3000
SBR 50L	5.260	50	11	11	7.5	10.8	62	38.8	95	70	11	200	M 10	3000

Misure della lunghezza a richiesta.

Sigla d'ordine: SBR - d - L - Lunghezza L.

Esempio: SBR 20L 1000 (modello SBR-L, diametro albero 20 mm, lunghezza L 1000 mm).

Under request different lengths available.

Specification number: SBR - d - L - Length L

Example: SBR 20L 1000 (SBR-L model, shaft diameter 20 mm, length L 1000 mm)

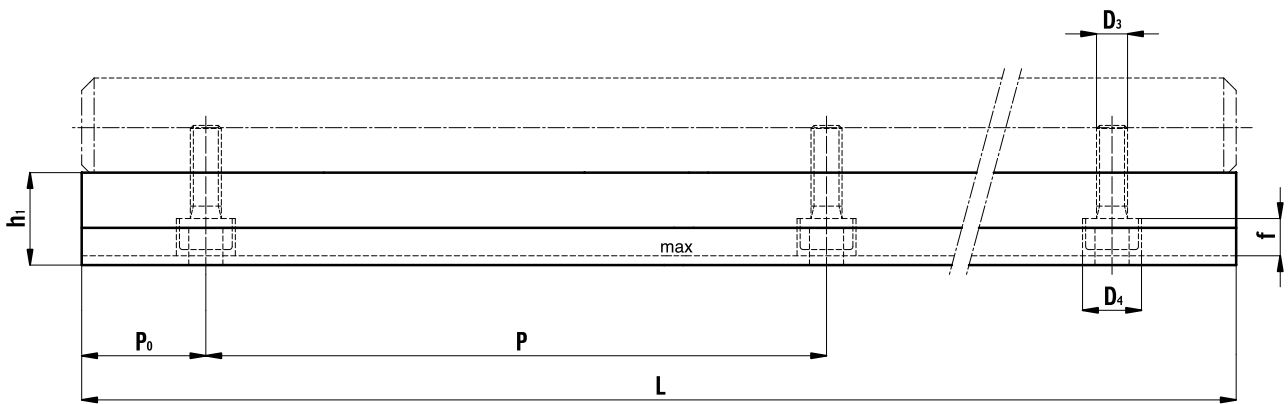
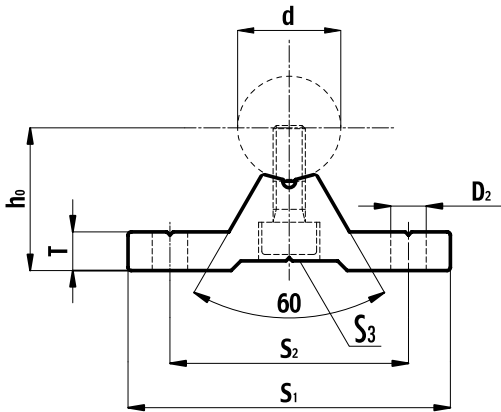
TBR-L

TIPOLOGIA TYPE	PESO WEIGHT [kg/m]	d [mm]	D ₂ [mm]	D ₃ [mm]	D ₄ [mm]	f [mm]	H ₀ [mm]	H ₁ [mm]	S ₁ [mm]	S ₂ [mm]	T [mm]	P [mm]	S ₃	L _{MAX}
TBR 16L	1.100	16	5.5	5.5	9.5	5.4	22.1	15	50	37	6	150	M 5	4000
TBR 20L	1.800	20	5.5	5.5	9.5	5.4	29	19.4	55	40	8	150	M 6	4000
TBR 25L	2.050	25	6.6	6.6	11	6.5	32	20.1	65	45	10	200	M 6	4000
TBR 30L	2.800	30	6.6	6.6	11	6.5	36.5	22.5	75	55	12	200	M 8	4000

Misure della lunghezza a richiesta.

Sigla d'ordine: TBR - d - L - Lunghezza L

Esempio: TBR 20L 1000 (modello TBR-L, diametro albero 20 mm, lunghezza L 1000 mm).

Under request different lengths available.

Specification number: TBR - d - L - Length L

Example: TBR 20L 1000 (model TBR-L, shaft diameter 20mm, Length L 1000 mm).

2.1. SERIE TSW-TSW...G

Serie **TSW** Senza fori **TSW...G** Forato
Lunghezza max L = 6000 mm

2.1. TSW-TSW...G SERIES

TSW Series without holes **TSW...G** With holes
Max. length L = 6000 mm

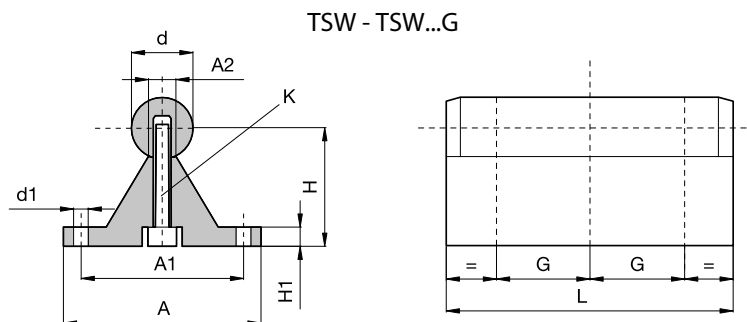

SIGLA CODE	d mm	A mm	H mm ± 0,2	A2 mm	H1 mm	A1 mm	d1 mm	G mm	K mm
TSW12	12	40	22	6	5	29	4,5	120	M 4 x 20
TSW16	16	54	32	7,5	6	41	5,5	150	M 5 x 25
TSW20	20	54	34,02	7,5	6	41	5,5	150	M 5 x 30
TSW25	25	65	39,66	10	6	51	6,6	150	M 6 x 35
TSW30	30	65	42,19	10	6	51	6,6	150	M 6 x 35
TSW40	40	85	60	17	10	65	9	150	M 10 x 50
TSW50	50	85	65,05	17	10	65	9	150	M 10 x 50

2.2 SUPPORTO CONTINUO PER ALBERO

Serie **TSN** Senza fori **TSN...G** Forato **TSN...G2** Forato
Lunghezza max L = 6000 mm

2.2. TSN-TSN...G-TSN...G2 SERIES

TSN Series without holes **TSN...G** With holes **TSN...G2** With holes
Max Length L = 6000 mm

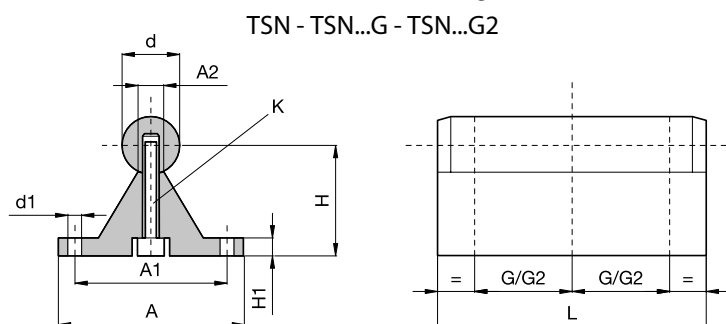

SIGLA CODE	d mm	A mm	H mm ± 0,2	A2 mm	H1 mm	A1 mm	d1 mm	G mm	G2 mm	K mm
TSN12	12	40	22	5,4	5	29	4,5	75	120	M 4 x 18
TSN16	16	45	26	7	5	33	5,5	100	150	M 5 x 20
TSN20	20	52	32	8,1	6	37	6,6	100	150	M 6 x 25
TSN25	25	57	36	10,3	6	42	6,6	120	200	M 8 x 30
TSN30	30	69	42	11	7	51	9	150	200	M 10 x 35
TSN40	40	73	50	15	9	55	9	200	300	M 10 x 40
TSN50	50	84	60	19	9	63	11	200	300	M 12 x 45
TSN60	60	94	68	25	10	72	11	300	300	M 14 x 50
TSN80	80	116	86	34	12	92	13,5	300	300	M 16 x 60

2.3. SERIE TSWA-TSWA...G-TSWA...G2
2.3. TSWA-TSWA...G-TSWA...G2 SERIES

Serie **TSWA** Senza fori **TSWA...G** Forato **TSWA...G2** Forato
 Lunghezza max L = 6000 mm

TSWA Series without holes **TSWA..G** With holes **TSWA..G2** With holes
 Max. length L = 6000 mm

TSWA

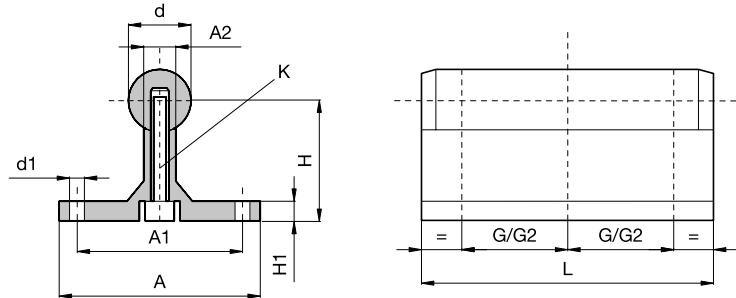

SIGLA CODE	d mm	A mm	A1 mm	A2 mm	H mm ± 0,2	H1 mm	d1 mm	G mm	G2 mm	K mm
TSWA12	12	43	29	5,4	28	5	4,5	75	120	M 4 x 20
TSWA16	16	48	33	7	30	5	5,5	100	150	M 5 x 25
TSWA20	20	56	37	8,1	38	6	6,6	100	150	M 6 x 30
TSWA25	25	60	42	10,3	42	6	6,6	120	200	M 8 x 35
TSWA30	30	74	51	11	53	8	9	150	200	M 10 x 40
TSWA40	40	78	55	15	60	8	9	200	300	M 10 x 45
TSWA50	50	90	63	19	75	10	11	200	300	M 12 x 20

2.4. SERIE TSU-TSU...G

Serie **TSU** Senza fori **TSU...G** Forato
Lunghezza max L = 600 mm

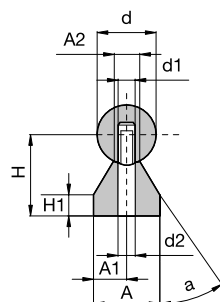

2.4. TSU-TSU...G SERIES

TSU Series without holes **TSU...G** With holes
Max. length L = 600 mm

TSU - TSU...G

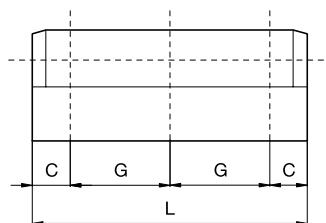

SIGLA	d mm	A mm	A1 mm	A2 mm	H mm ± 0,2	H1 mm	d1 mm	d2 mm	G mm	C mm
TSU12G	12	11	5,5	5,4	14,5	3	M4	4,5	37,5	75
TSU16G	16	14	7	7	18	3	M5	5,5	37,5	75
TSU20G	20	17	8,5	8,1	22	3	M6	6,6	37,5	75
TSU25G	25	21	10,5	10,3	26	3	M8	9	37,5	75
TSU30G	30	23	11,5	11	30	3	M10	11	50	100
TSU40G	40	30	15	15	39	4	M12	13,5	50	100
TSU50G	50	35	17,5	19	46	5	M14	15,5	50	100

2.5. SERIE TSS TSC

Serie **TSS TSC**
Lunghezza max L = 600 mm

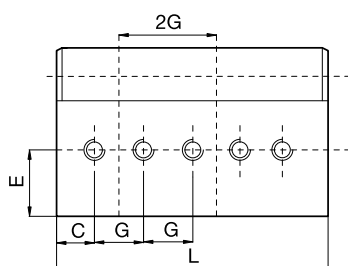
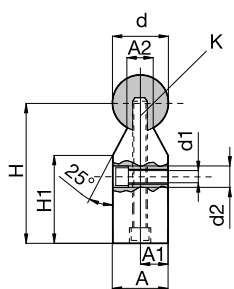

2.5. TSS TSC SERIES

TSS TSC Series
Max. length L = 600 mm

TSS - TSC

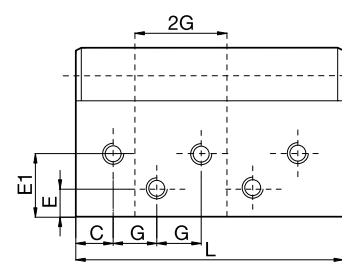
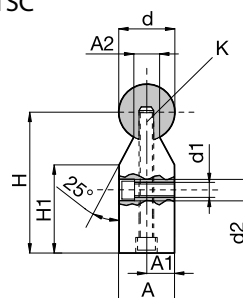

SIGLA	d mm	A mm	A1 mm	A2 mm	H mm ± 0,2	H1 mm	d1 mm	d2 mm	15E mm	E1 mm	C mm	G mm	K mm
TSS20	20	15	7,5	8,1	52	36,5	6,6	11	15	-	25	50	M 6
TSC20	20	15	7,5	8,1	52	36,5	6,6	11	8	22	18,75	37,5	M 6
TSS25	25	20	10	10,3	62	38,5	9	15	18	-	30	60	M 8
TSC25	25	20	10	10,3	62	38,5	9	15	10	26	18,75	37,5	M 8
TSS30	30	25	12,5	11	72	43	11	18	21	-	37,5	75	M 10
TSC30	30	25	12,5	11	72	43	11	18	12	30	25	50	M 10
TSS40	40	30	15	15	88	53	13,5	20	25	-	50	100	M 12
TSC40	40	30	15	15	88	53	13,5	20	12	38	25	50	M 12
TSS50	50	35	17,5	19	105	64,5	15,5	24	30	-	50	100	M 14
TSC50	50	35	17,5	19	105	64,5	15,5	24	15	45	25	50	M 14

