

Goodrive200 Series

General Purpose Inverter

Innovation, Value, Teamwork



invt

SHENZHEN INVT ELECTRIC CO.,LTD.

- Industrial Automation :** ■ Frequency Inverter ■ Servo & Motion Control ■ Motor & Electric Spindle ■ PLC
 ■ HMI ■ Intelligent Elevator Control System ■ Traction Drive
- Electric Power :** ■ SVG ■ Solar Inverter ■ UPS ■ Online Energy Management System

INVT Copyright.
Information may be subject to change without notice during product improving.

201307(V2.0)



invt

Brief introduction of Goodrive200

Based on DSP control system, Goodrive200 inverters apply SVPWM control and a variety of protections for asynchronous motor drive. The air duct, hardware and software have been greatly improved for better environment adaptability and operation. The inverter passed CE certification of TÜV SÜD, ensuring safe use of clients.

Advantages



Product Profile	01
Advantages	01
• High performance	03
• Multi-function with simple operation	04
• Reliable quality certificated by TÜV SÜD	08
Applications	10
Technical Specifications	11
Wirings	13
Power Ratings	14
Dimensions	15
Optional Parts	21
Sales&Service Network	25



High Performance



1. More Accurate Motor Autotuning

Accurate rotating and static motor autotuning
Convenient debugging and easy operation

Rotating Autotuning

De-couple from the load
Applied to the situation
with high control accuracy

Static Autotuning

No need to de-couple from the load
Applied when rotating autotuning is
not available

2. Optimized V/F Control

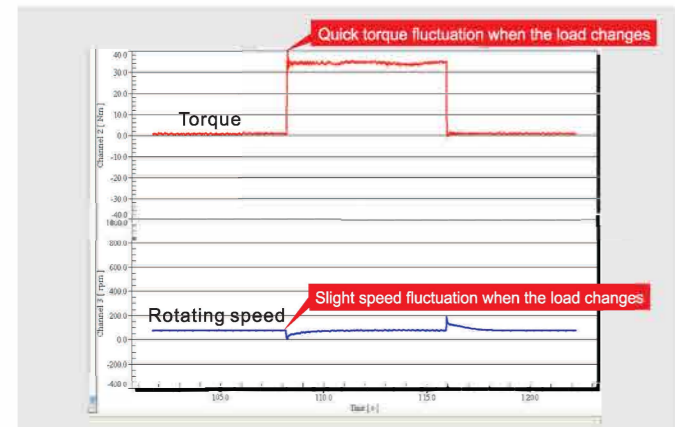
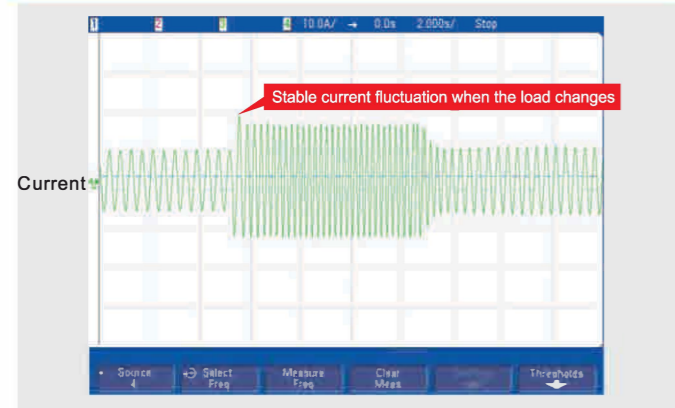

The current, torque and speed waveforms when sudden loading or unloading in SVPWM control mode with 2Hz running frequency and full load.

3. Perfect voltage and current control, reducing the fault protection times

OC Fault

Adjust the output frequency to avoid over-current of the inverter during acceleration

OV Fault

Adjust the output frequency to avoid over-voltage of the DC bus during deceleration

4. Multiple braking modes and instant stopping

Dynamic Braking	DC Braking	Flux Braking
Configure braking units and resistors	No need to configure braking units and resistors	No need to configure braking units and resistors
Available on the situation of big inertia load and frequent braking	Available on the situation when start the running motor after braking and the situation when keep the moment output after braking to zero speed	Available on the instant stopping situation with big inertia load and no frequent braking
Big braking torque and quick braking	Not available on the situation of big inertia load or instant stopping braking in high speed running	Not available on the situation of big inertia load and frequent braking (the energy consumed on the stator and its cooling is better than DC braking)

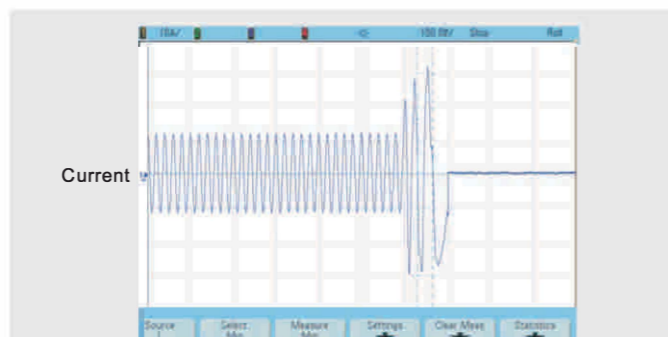

Flux braking current waveform when the running frequency is 50Hz, deceleration time is 0.1s with full load in asynchronous motor SVPWM control mode.

Multi-function with simple operation



1. Separate Air-duct

The separate air duct prevents the contaminants into the electronic parts/components and greatly improves the protective effect of the inverter, as well as its reliability and service life, to adapt various complicated site environments. It can also facilitate the heat-releasing in control cabinets and the heat-releasing design of the customer.

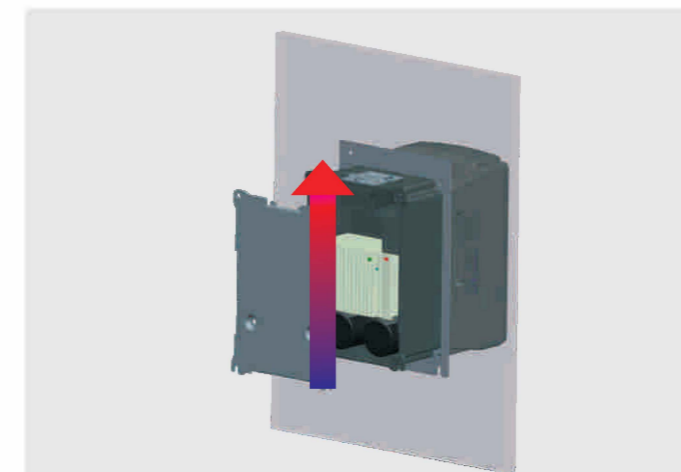

2. Multiple Installation Modes

1.5~200kW: Wall mounting and flange mounting
200~315kW: Wall mounting and floor mounting
350~500kW: Floor mounting
Remark: above power ratings are subject to G type machine.



3. C3 input filter (standard configuration) and C2 filter (optional)

C3 input filter is embedded in the factory to meet different application requirements, save installation space and avoid electromagnetic interference caused by incorrect selection and site installation.

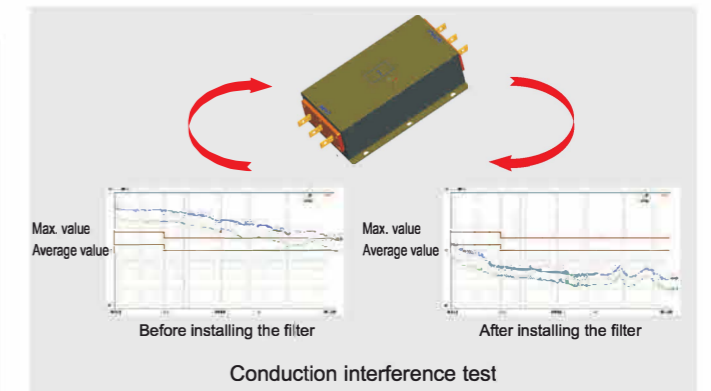

Remarks:
C2 filter: EMC performance of the inverter achieves the limited usage requirement in civil environment.
C3 filter: EMC performance of the inverter achieves the limited usage requirement in industrial environment.

4. Book Structure

Parallel installation
Smaller installation space with less cost and beautiful appearance.



5. The rivet design ensures reliable integration connection

Greener Proper grounding
Stronger corrosion-resistance Excellent EMC performance



Terminals	Quantity	Features
ON-OFF input	8 channels	1KHz NPN and PNP
High speed pulse input	1 channel	50KHz NPN and PNP
Analog input	3 channels	AI1, AI2 0~10V/0~220mA AI3 -10~10V
ON-OFF output	1 channel	Max. output frequency:1KHz
High speed pulse output	1 channel	Max. output frequency:50KHz
Analog output	2 channels	0~10V, 0~20mA
Relay output	2 channels	3A/250V AC, 1A/30V DC, NO+NC

6. Smaller Size

Due to the thermal simulation and advanced modularized design, the size of our product is reduced greatly. The width ratio between Goodrive300 and CHF100A is shown in the figure below (the Max. percentage is 50%)

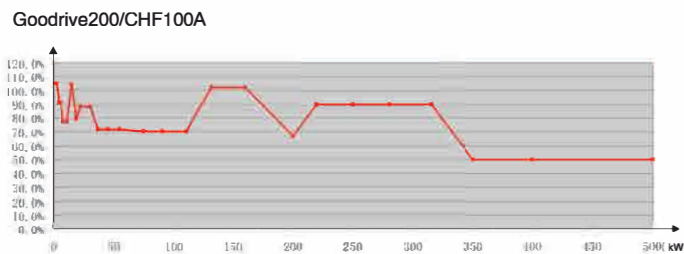

8. High Performance Keypad



7. Various external interfaces and swappable terminal board convenient for replacement and maintenance

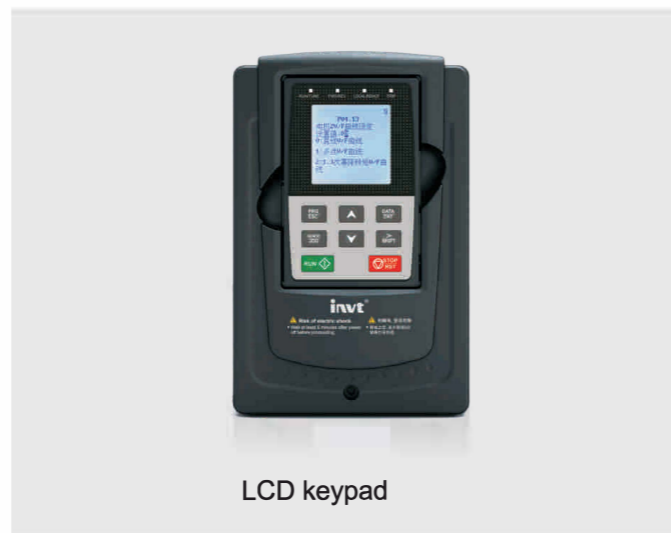

The standard LED keypad supports parameters loading and unloading with Max. length of 200m and digital potentiometer. The optional external LCD keypad supports parameters loading and unloading with displaying 10 lines and 10 rows of Chinese characters and several languages.
Remarks: LCD keypad is in research. It is estimated to accept orders after May, 2012.

9. Embedded braking units of 1.5~30kW inverters

Reduce the occupied space and decrease the cost

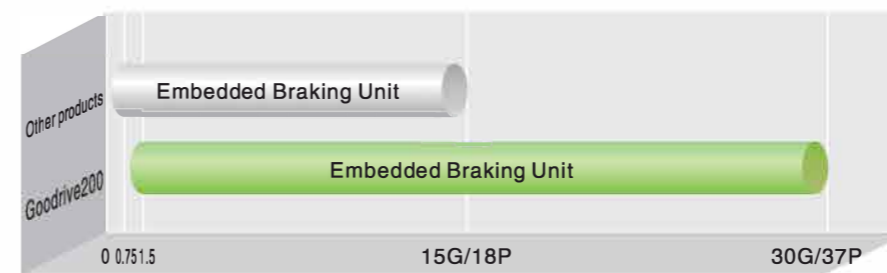

10. Supporting common DC bus

Reduce the power lost on DBR
Note the impact current and the capacity of the input AC system

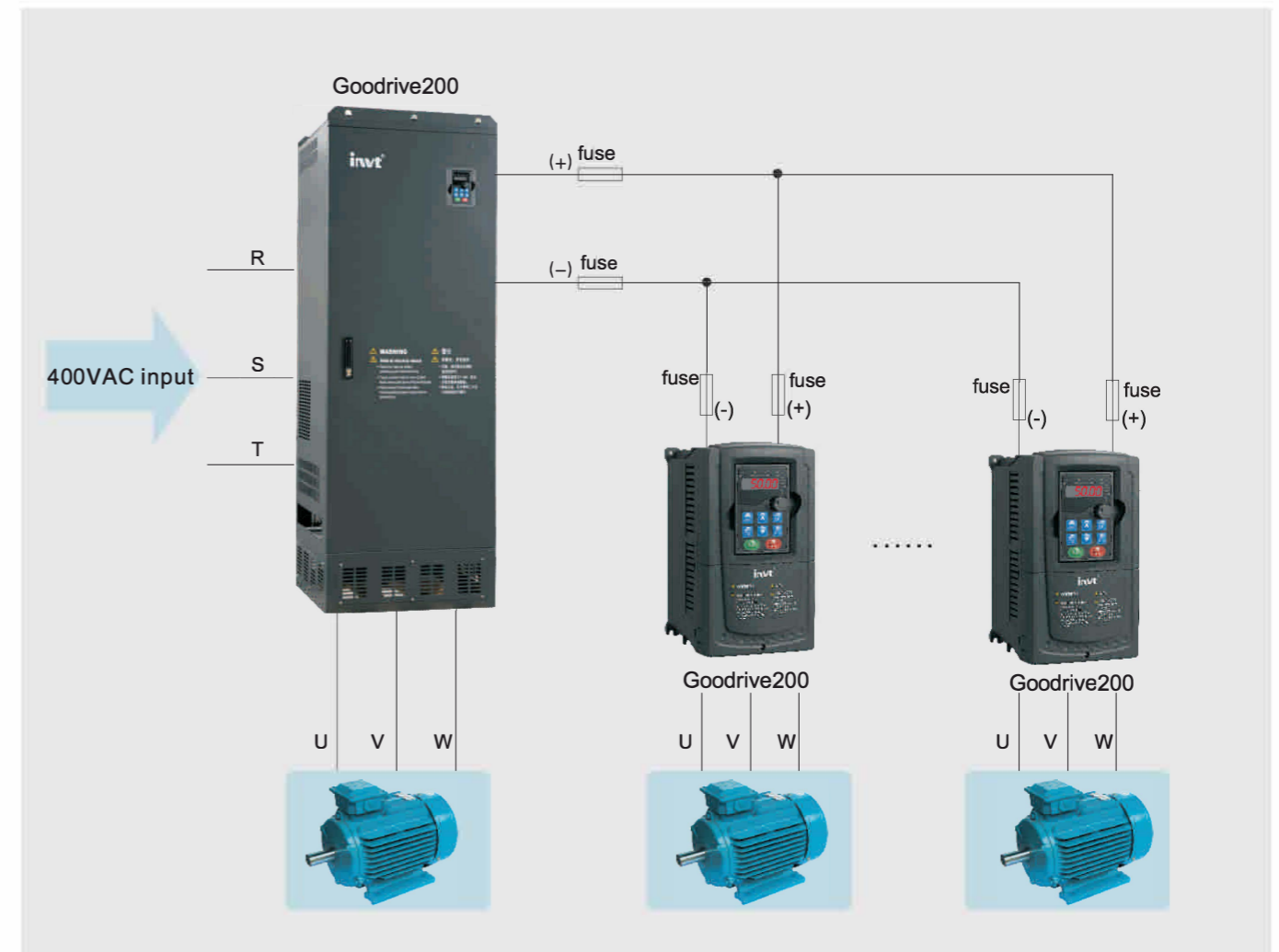

11. Available on DC power supply

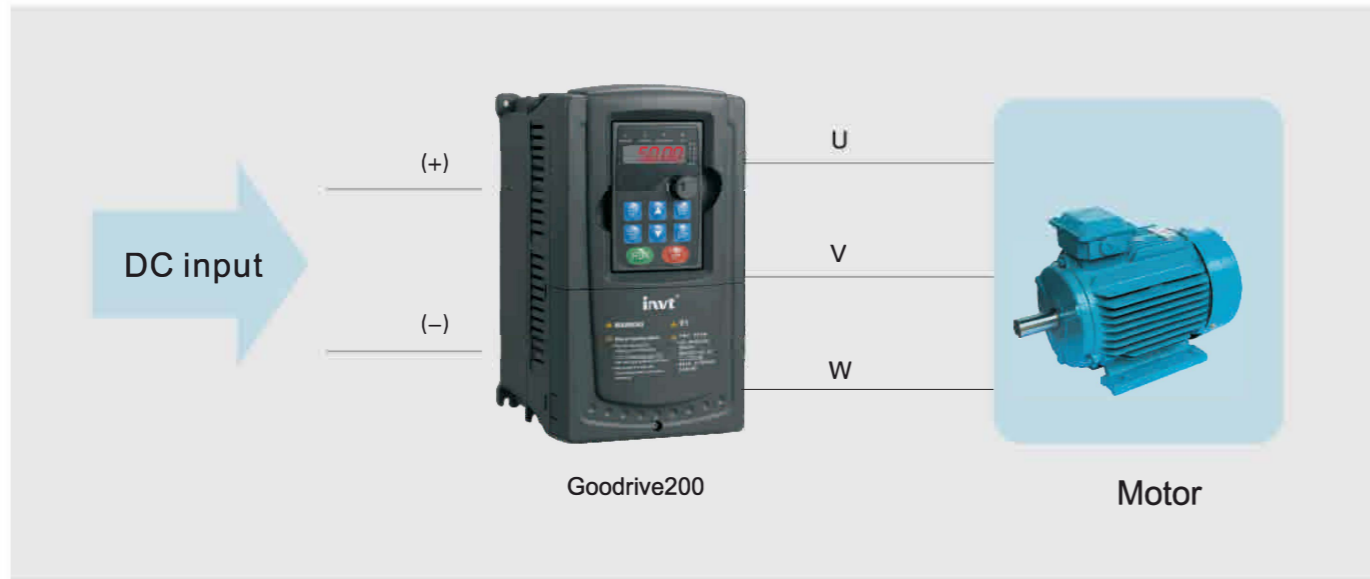

12. Simple water supply mode

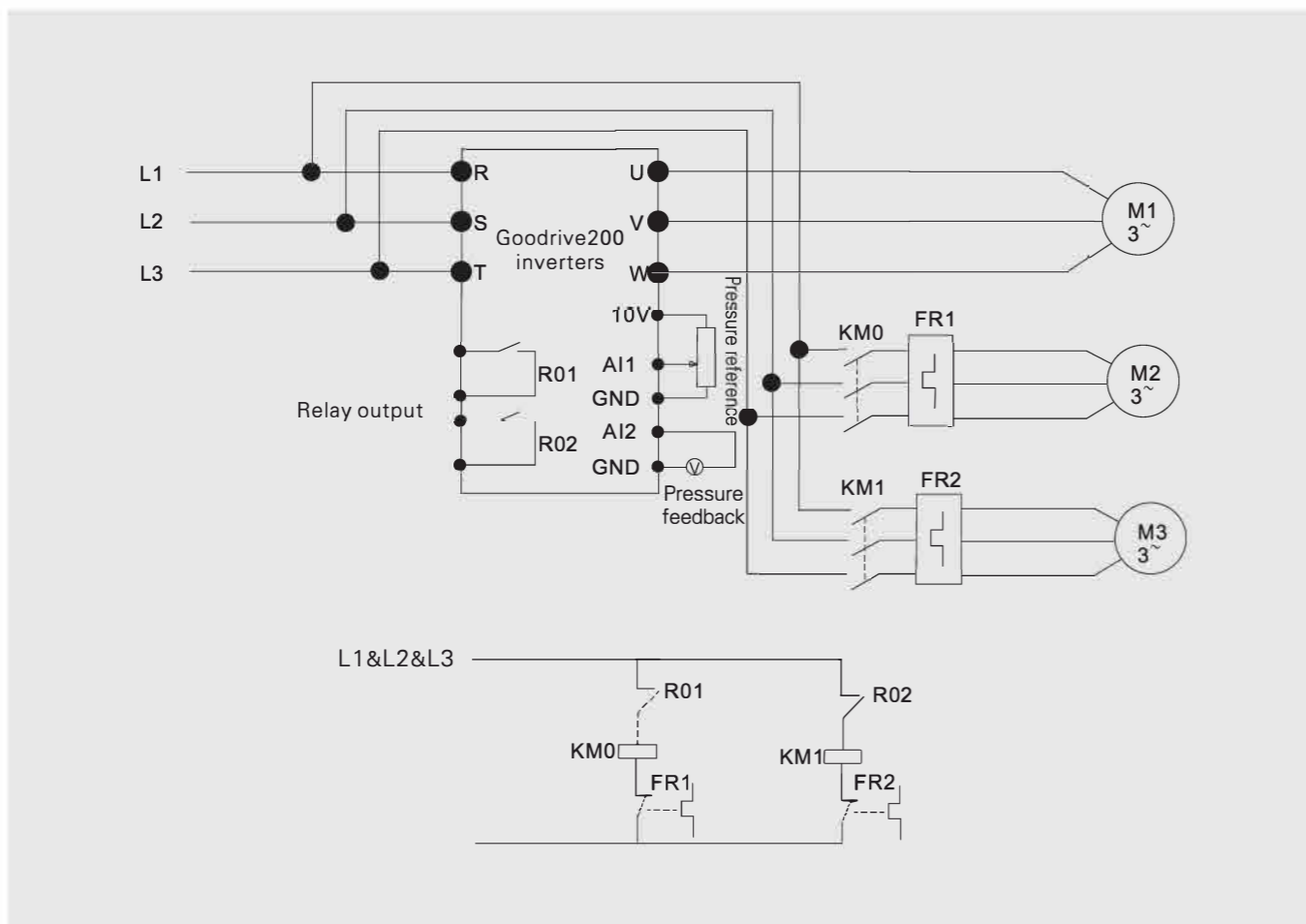

In the diagram above, M2 and M3 are auxiliary motors which are controlled by R01 and R02. PID constant-pressure automatic control system is formed by the inverter through pressure feedback. The pressure reference can apply analog or keypad input, Modbus 485 communication protocol is also supported.

Reliable quality certificated by TÜV SÜD



1. The product design follows IEC national standards and passes the CE test of international authority TÜV SÜD, INVT is the unique manufacturer having TÜV-MARK marks in Chinese industrial control field.

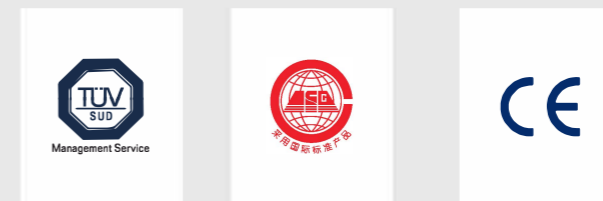

Remarks: Each Goodrive200 inverter has past the test certification

2. Advanced thermal technology makes exact thermal design

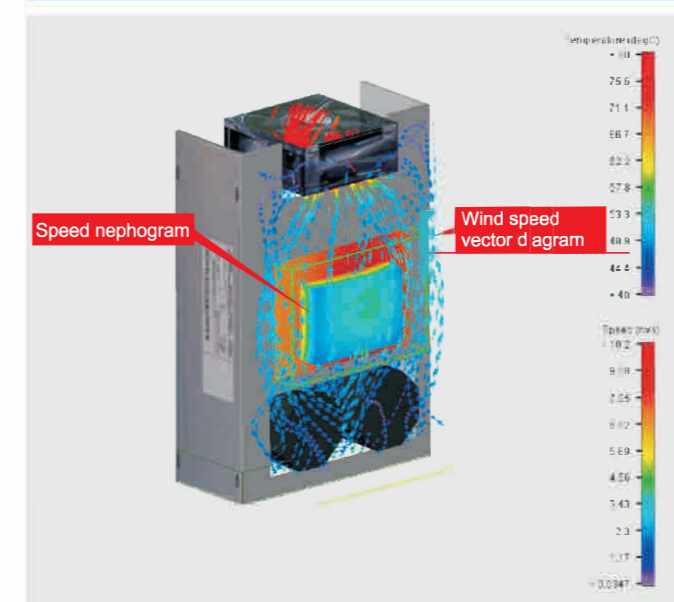

3. Wide voltage range meets the requirement of grid environment

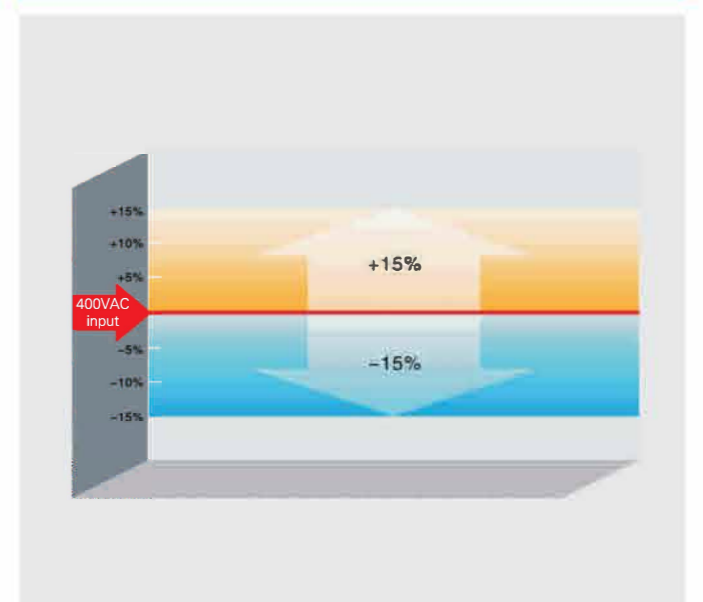

Applications



Air compressors



Plastic machinery



Petroleum



Mining



Hvac and water supply



Fan and water pumps

4. Perfect and reliable test system ensure products adapt complicated site environments and INVT is the only manufacturer achieved ACT certificate of TÜV SÜD

Experiment Type	Experiment Name	Classification
Mechanical Reliability Experiments	Package Experiments	Package compression experiments
		Package resonance imaging and storage test
		Package random vibration test
		Package dropping test
		Package rolling test
		Package dumping test
		Package inclined impact test
	Impact Test	Half-sine wave impulse test(non-working state)
		Trapezoidal wave impulse test (non-working state)
	Vibration Test	Sinusoidal vibration test (working state)
Random vibration test (working and non-working state)		
Climatic Environmental Reliability Test	Temperature Experiment	Low temperature storage test
		High temperature storage test
		Low temperature experiments
		High temperature experiments
		Temperature gradient experiments
		Temperature impact test
	Thermal Test	Constant thermal test
		Alternation thermal test
	Salt Spray Test	Constant salt spray test
		Alternation salt spray test
Low Air Pressure Test	Low Air Pressure Test	
	Low temperature and low pressure test	
		High temperature and low pressure test

Remarks:

The full name of ACT is Acceptance of Client's Testing, which means the German TÜV SÜD admit the technology level of the lab and accept their separate testing data and test reports officially.



Electric Vibration System



Low Pressure Test Chamber (L)
Constant Temperature and Humidity Test Chamber (R)



Natural Convection Test Chamber (L)
Thermal Shock Test Chamber (R)

Technical Specifications

Function		Specification
Input	Input Voltage (V)	AC 3PH 380V (-15%)~440V (+10%)
	Input Frequency (Hz)	50Hz or 60Hz Allowed range: 47~63Hz
Output	Output Voltage (V)	0~input voltage
	Output Frequency (Hz)	0~400Hz
Technical Control Feature	Control Mode	SVPWM
	Motor Type	Asynchronous motor
	Speed-adjusting Ratio	Asynchronous motor 1:100
	Starting Torque	Asynchronous motor: 0.5Hz/150%
	Overload Capability	G type: 150% of rated current: 1 minute 180% of rated current: 10 seconds 200% of rated current: 1 second P type: 120% of rated current: 60 seconds
Running Control Feature	Frequency Setting	Digital setting, analog setting, pulse frequency setting, multi-step speed running setting, simple PLC setting, PID setting, MODBUS communication setting. Realize the shifting between the set combination and set channel.
	Auto Voltage Adjustmen	Keep a stable voltage automatically when the grid voltage fluctuates
	Fault Protection	Provide over 30 fault protection functions: overcurrent, overvoltage, undervoltage, overheating, phase failure and overload, etc.
	Speed Tracking	Restart the rotating motor smoothly

Function		Specification
Peripheral Interface	Terminal Analog Input Resolution	≤10mV
	Terminal Switch Input Resolution	≤2ms
	Analog Input	2 channels (AI1, AI2) 0~10V/0~20mA and 1 channel (AI3) -10~10V
	Analog Output	2 channels (AO1, AO2) 0~10V /0~20mA
	Digital Input	8 channels common input, the Max. frequency: 1kHz 1 channel high speed pulse input, the Max. frequency: 50kHz
	Digital Output	1 channel high speed pulse output, the Max. frequency: 50kHz; 1 channel Y terminal open collector output
Others	Relay Output	2 channels programmable relay output RO1A NO, RO1B NC, RO1C common terminal RO2A NO, RO2B NC, RO2C common terminal Contactor capability: 3A/AC250V, 1A/DC30V
	Mountable Method	Wall, flange and floor mountable
	Temperature of the running environment	-10~50℃, derate above 40℃
	Ingress Protection	IP20
	Cooling	Air-cooling
	Braking Unit	Built-in braking unit for below 30G/37P (including 30G/37P) External braking unit for others
	Braking Resistor	Optional external configuration
EMC Filter	Built-in C3 filter: meet the degree requirement of IEC61800-3 C3 External filter: meet the degree requirement of IEC61800-3 C2	

Wirings

Wiring diagram of the main circuit

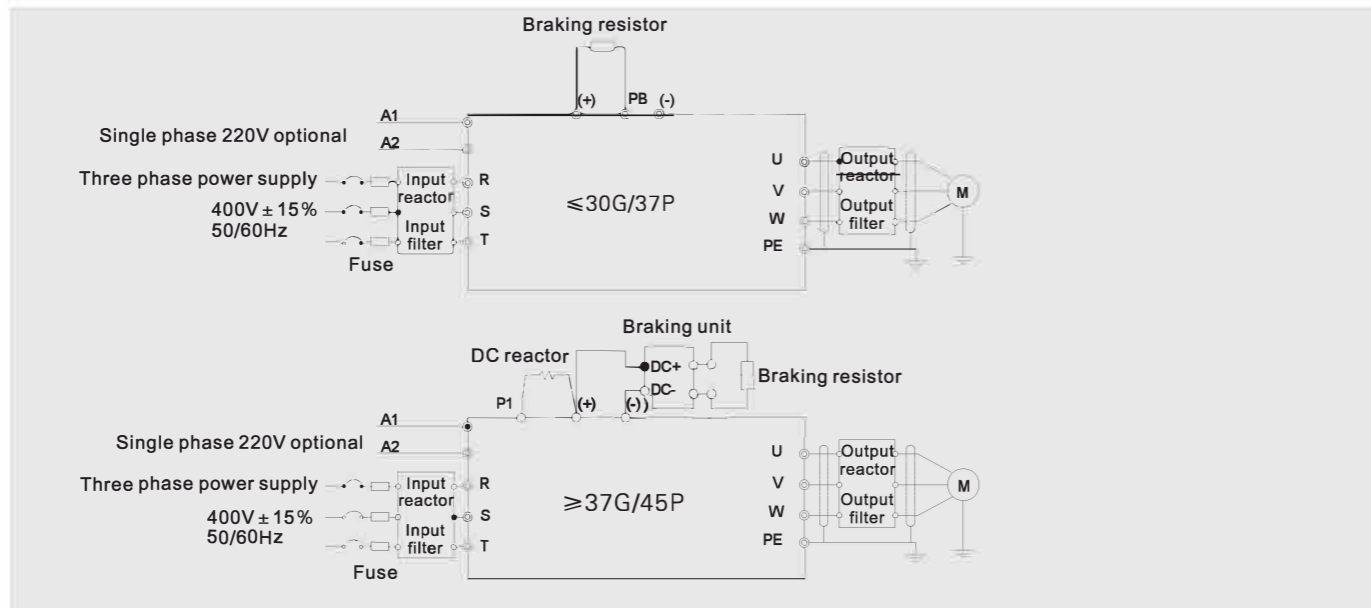

Wiring diagram of the control circuit

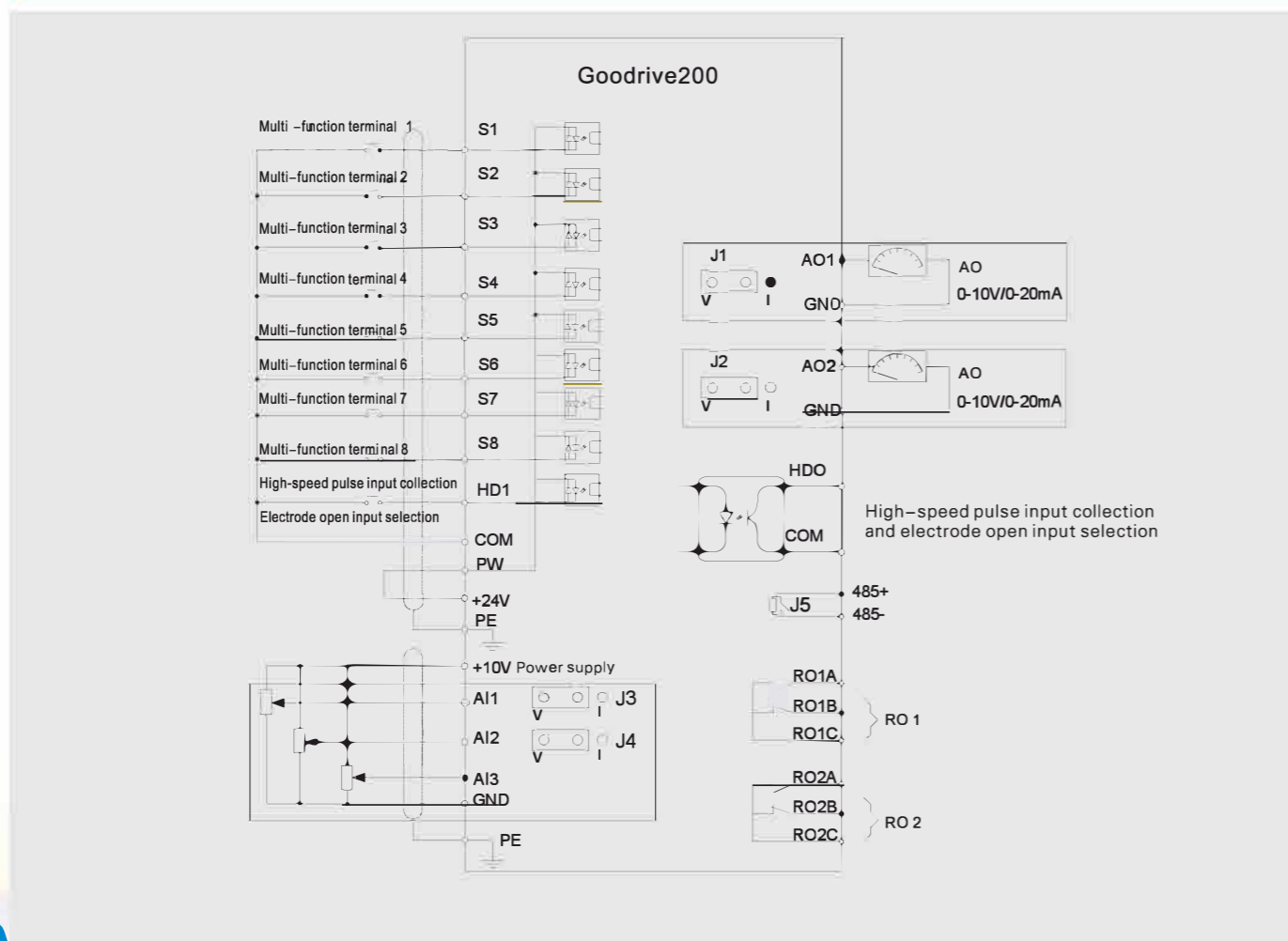

Power Ratings

Inverter Model	Rated Output Power (kW)	Rated Input Current (A)	Rated Output Current (A)
GD200-1R5G-4	1.5	5.0	3.7
GD200-2R2G-4	2.2	5.8	5
GD200-004G/5R5P-4	4/5.5	13.5/19.5	9.5/14
GD200-5R5G/7R5P-4	5.5/7.5	19.5/25	14/18.5
GD200-7R5G/011P-4	7.5/11	25/32	18.5/25
GD200-011G/015P-4	11/15	32/40	25/32
GD200-015G/018P-4	15/18.5	40/47	32/38
GD200-018G/022P-4	18.5/22	47/56	38/45
GD200-022G/030P-4	22/30	56/70	45/60
GD200-030G/037P-4	30/37	70/80	60/75
GD200-037G/045P-4	37/45	80/94	75/92
GD200-045G/055P-4	45/55	94/128	92/115
GD200-055G/075P-4	55/75	128/160	115/150
GD200-075G/090P-4	75/90	160/190	150/180
GD200-090G/110P-4	90/110	190/225	180/215
GD200-110G/132P-4	110/132	225/265	215/260
GD200-132G/160P-4	132/160	265/310	260/305
GD200-160G/200P-4	160/200	310/385	305/380
GD200-200G/220P-4	200/220	385/430	380/425
GD200-220G/250P-4	220/250	430/485	425/480
GD200-250G/280P-4	250/280	485/545	480/530
GD200-280G/315P-4	280/315	545/610	530/600
GD200-315G/350P-4	315/350	610/625	600/650
GD200-350G/400P-4	350/400	625/715	650/720
GD200-400G-4	400	715	720
GD200-500G-4	500	890	860

Remarks:

1. The input current of the inverter 1.5G-315G/350P is tested when the input voltage is 380V and there is no DC reactor and output/input reactor.
2. The current of the inverter 350G/400P-500G is tested when the input voltage is 380V and there is input reactor.
3. Rated output current is defined when the rated output voltage is 380V.

Dimensions (Unit:mm, below power ratings are subject to G type machine and referred for P type machine.)

Dimensions

■ Installation dimension when wall mounting

Inverter Model	W1	W2	H1	H2	D1	Installation Hole
1.5kW~2.2kW	126	115	193	175	174.5	5
4kW~5.5kW	146	131	263	243.5	181	6
7.5kW~11kW	170	151	331.5	303.5	216	6
15kW~18.5kW	230	210	342	311	216	6
22kW~30kW	255	237	407	384	245	7
37kW~55kW	270	130	555	540	325	7
75kW~110kW	325	200	680	661	365	9.5
132kW~200kW	500	180	870	850	360	11
220kW~315kW	680	230	960	926	379.5	13

■ Installation dimension when flange mounting

Inverter Model	W1	W2	W3	W4	H1	H2	H3	H4	D1	D2	Installation Hole
1.5kW~2.2kW	150	115	130	7.5	234	220	190	16.5	174.5	65.5	5
4kW~5.5kW	170	131	150	9.5	292	276	260	10	181	79.5	6
7.5kW~11kW	191	151	174	11.5	370	351	324	15	216.2	113	6
15kW~18.5kW	250	210	234	12	375	356	334	10	216	108	6
22kW~30kW	275	237	259	11	445	426	404	10	245	119	7
37kW~55kW	270	130	261	65.5	555	540	516	17	325	167	7
75kW~110kW	325	200	317	58.5	680	661	626	23	363	182	9.5
132kW~200kW	500	180	480	60	870	850	796	37	358	178.5	11

■ Installation dimension when floor mounting

Inverter Model	W1	W2	W3	W4	H1	H2	D1	D2	Installation Hole
220kW~315kW	750	230	714	680	1410	1390	380	150	13\12
350kW~500kW	620	230	553	-	1700	1678	560	240	22\12

Installation Diagram

■ Wall mounting for 1.5~30kW inverters

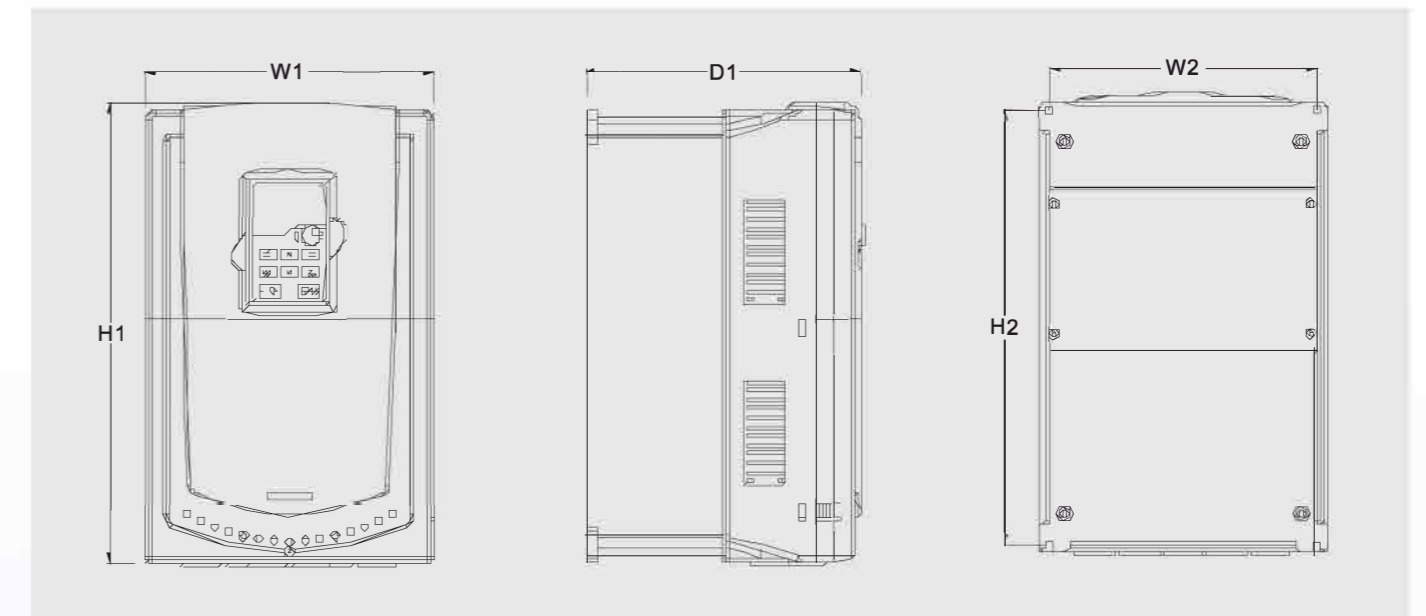

■ Wall mounting for 37~110kW inverters

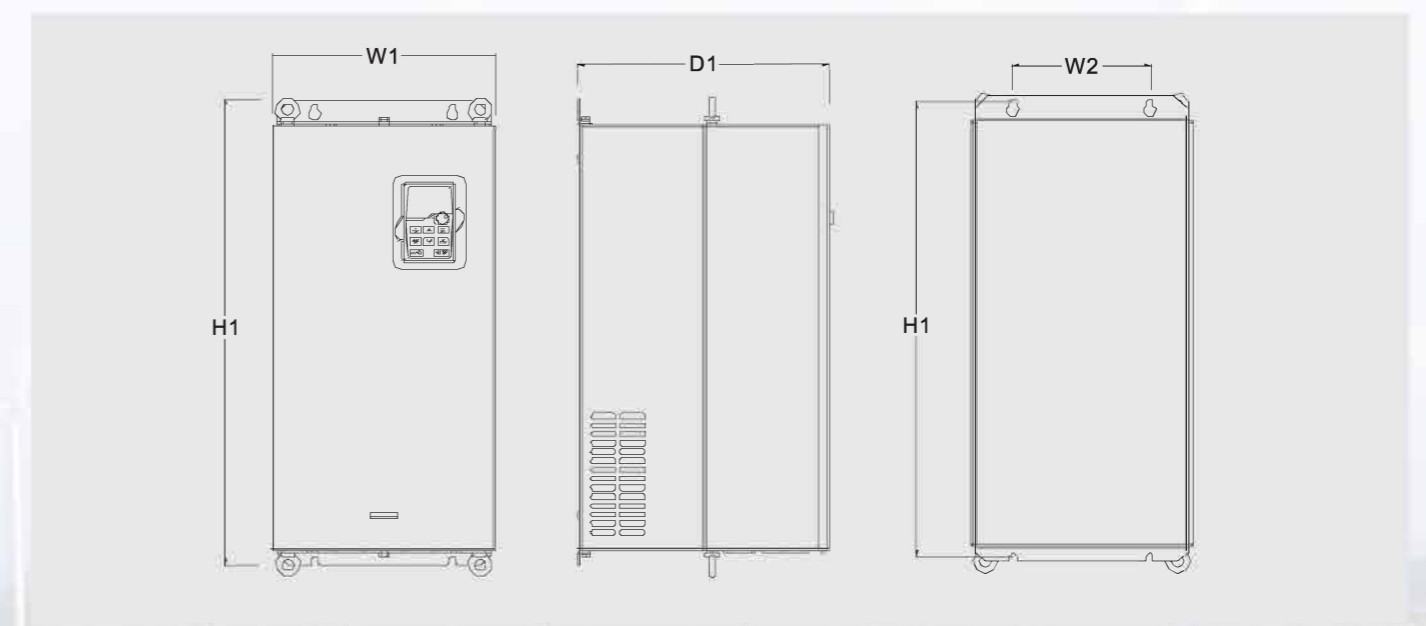

■ Wall mounting for 132~200kW inverters

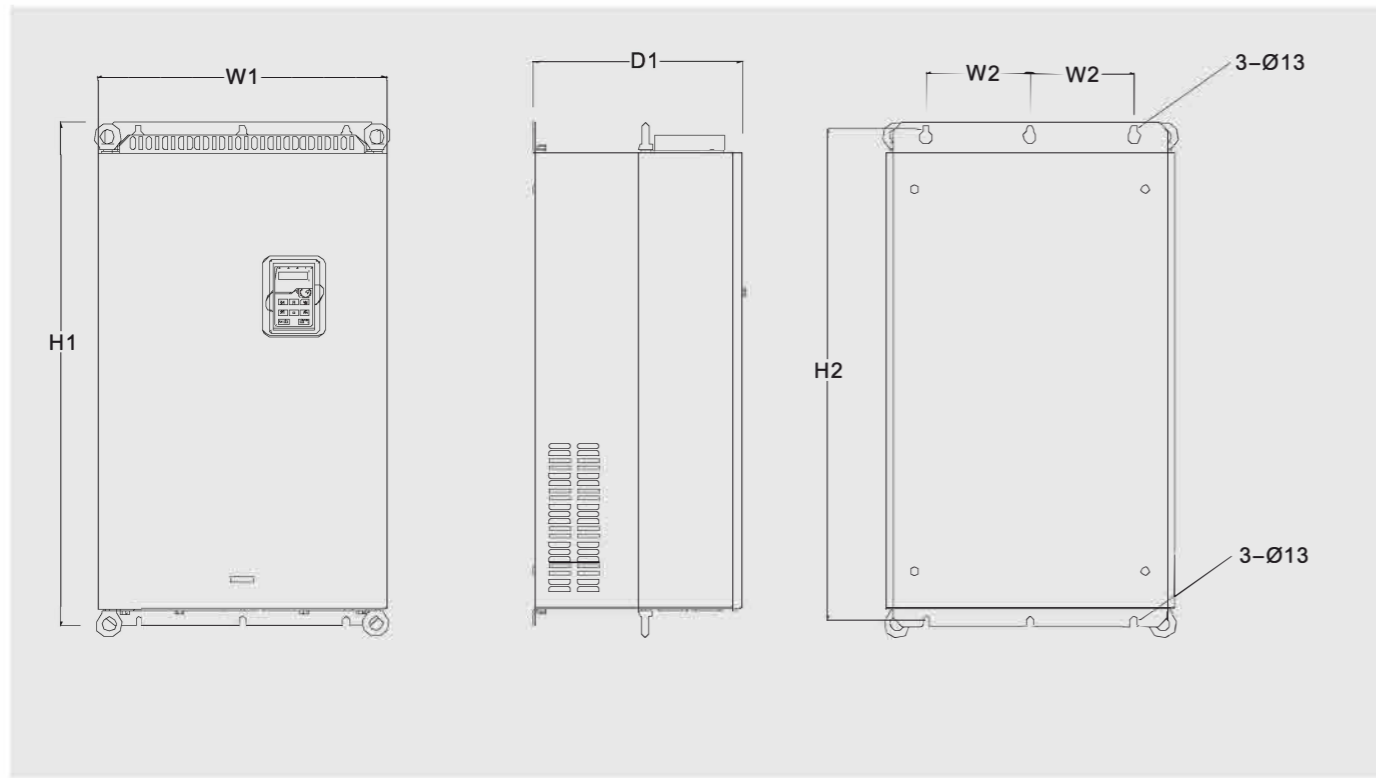

■ Flange mounting for 1.5~30kW inverters

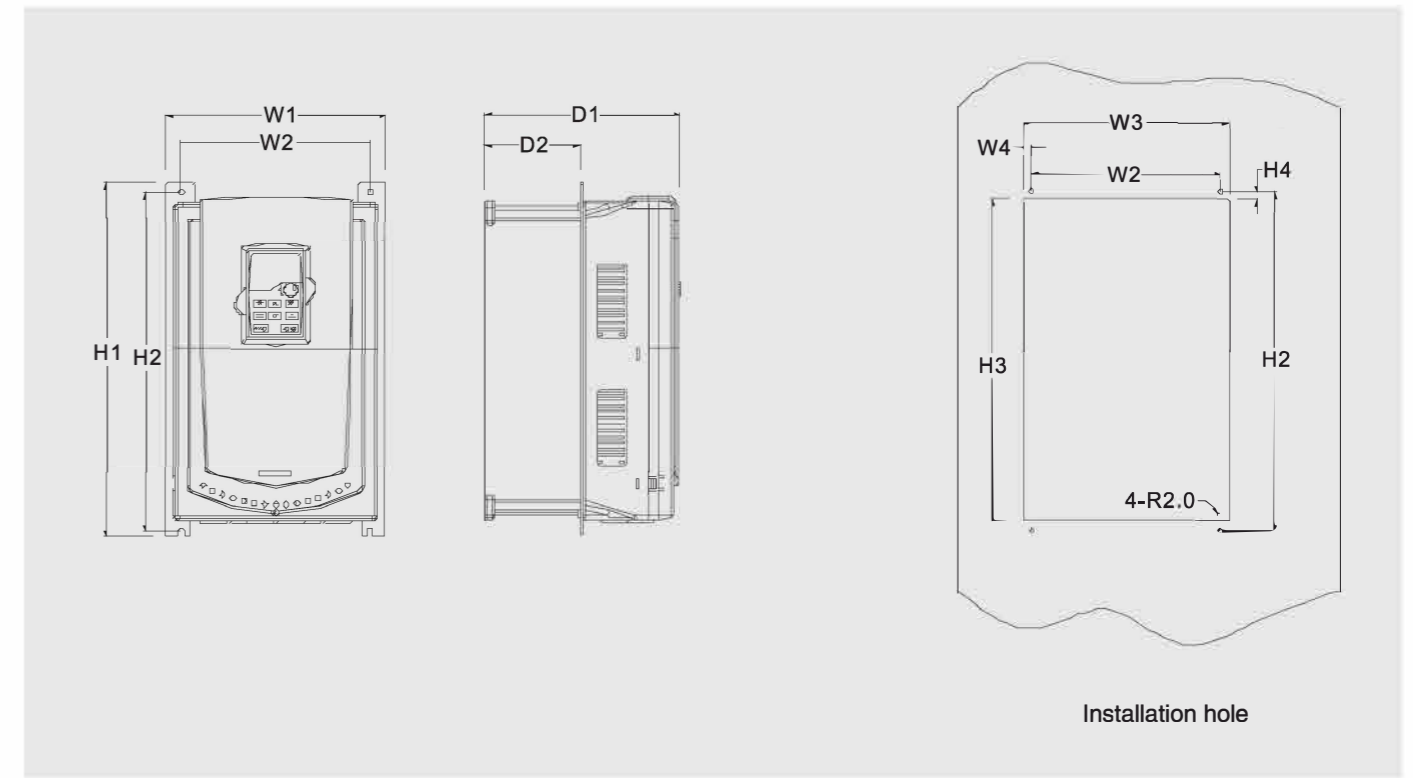

■ Wall mounting for 220~315kW inverters

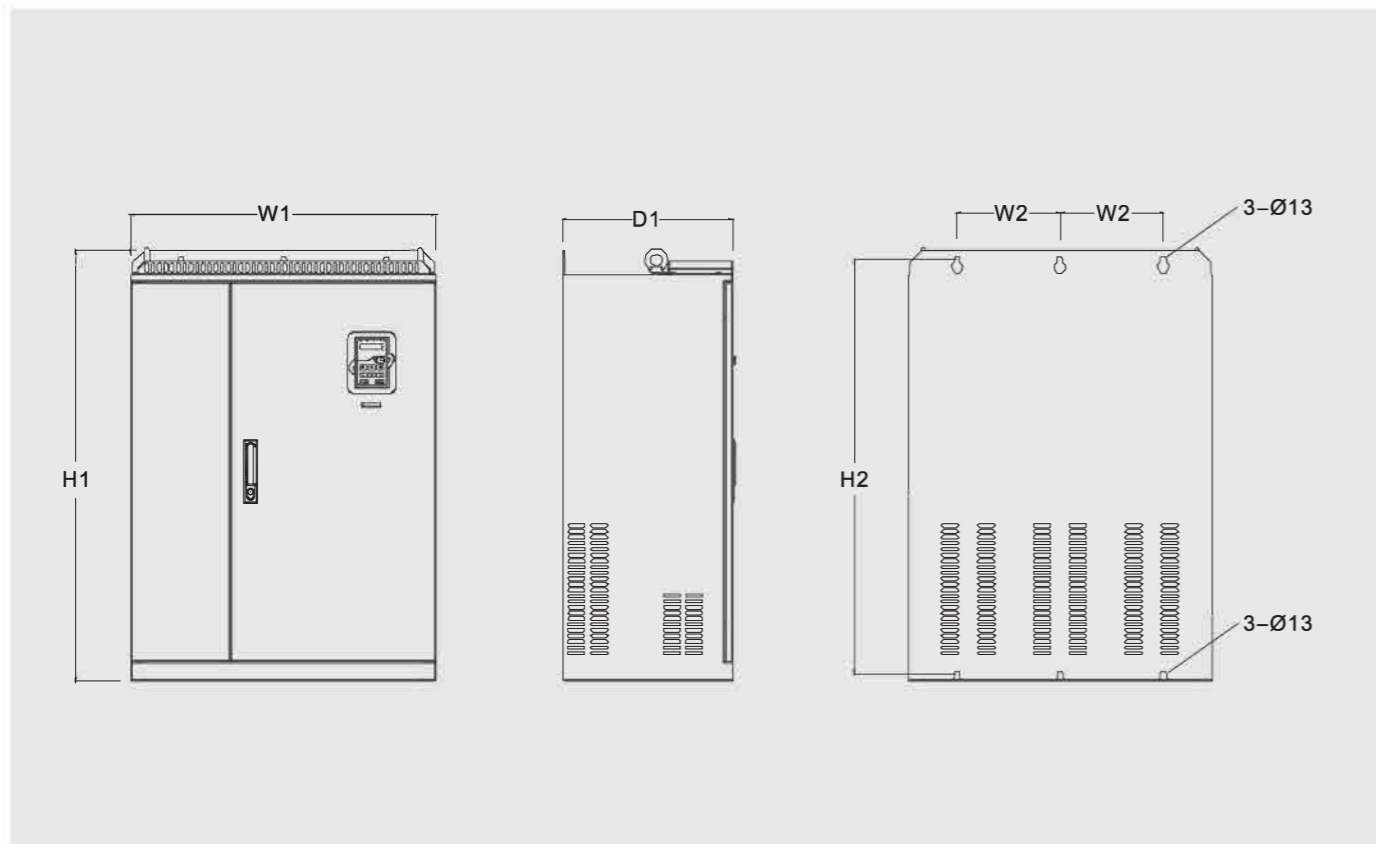

■ Flange mounting for 37~110kW inverters

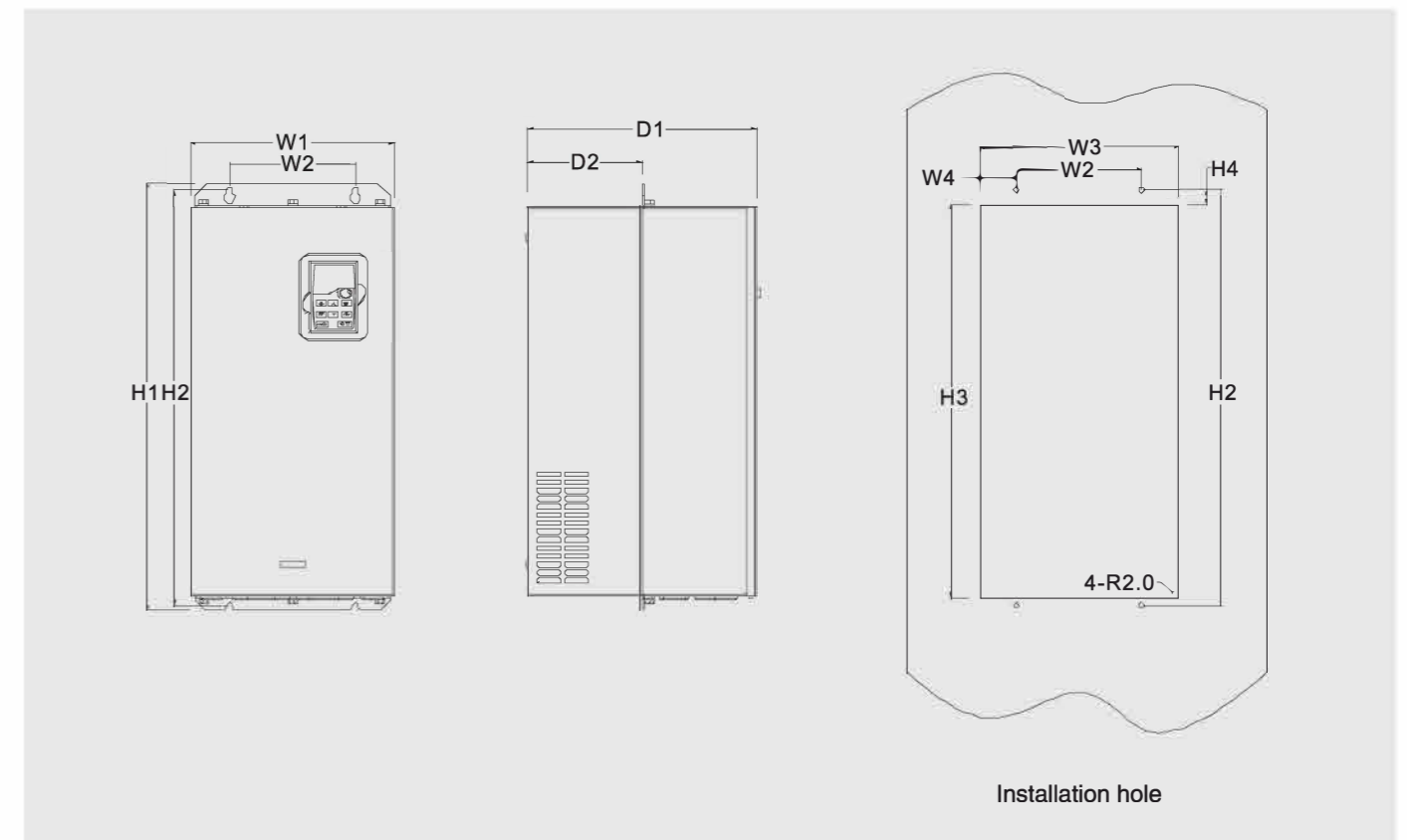

■ Flange mounting for 132~200kW inverters

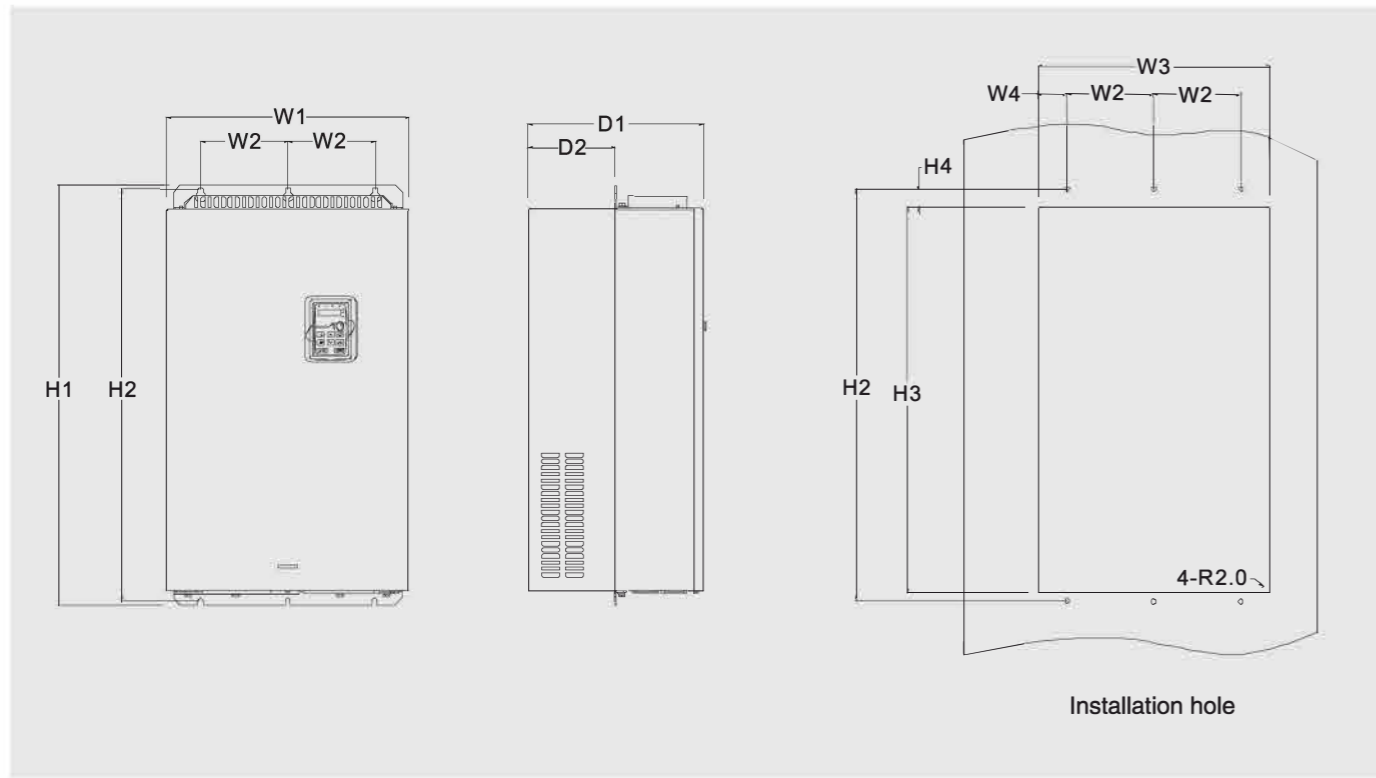

■ Floor mounting for 350kW~500kW inverters

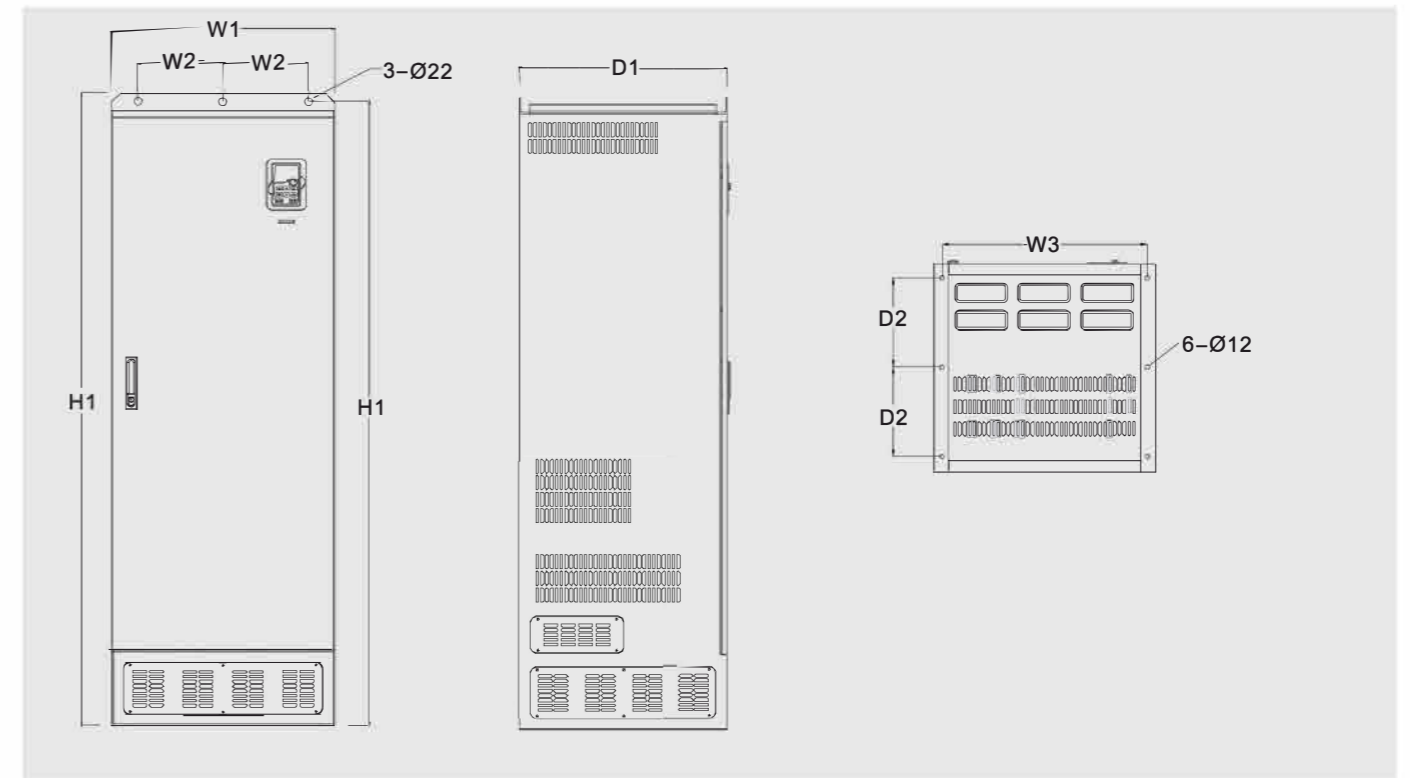

■ Floor mounting for 220~315kW inverters

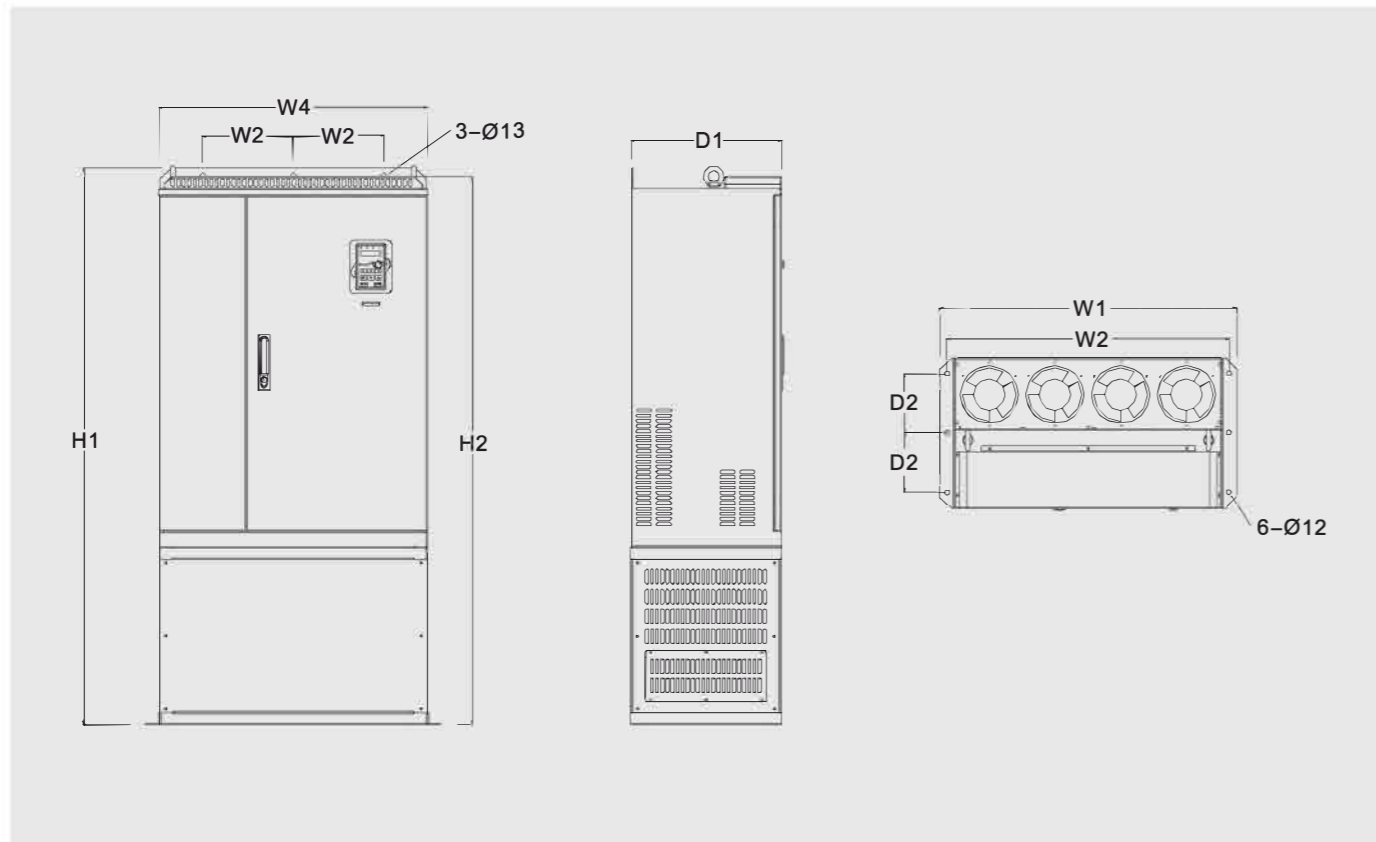

■ Keypad Dimension

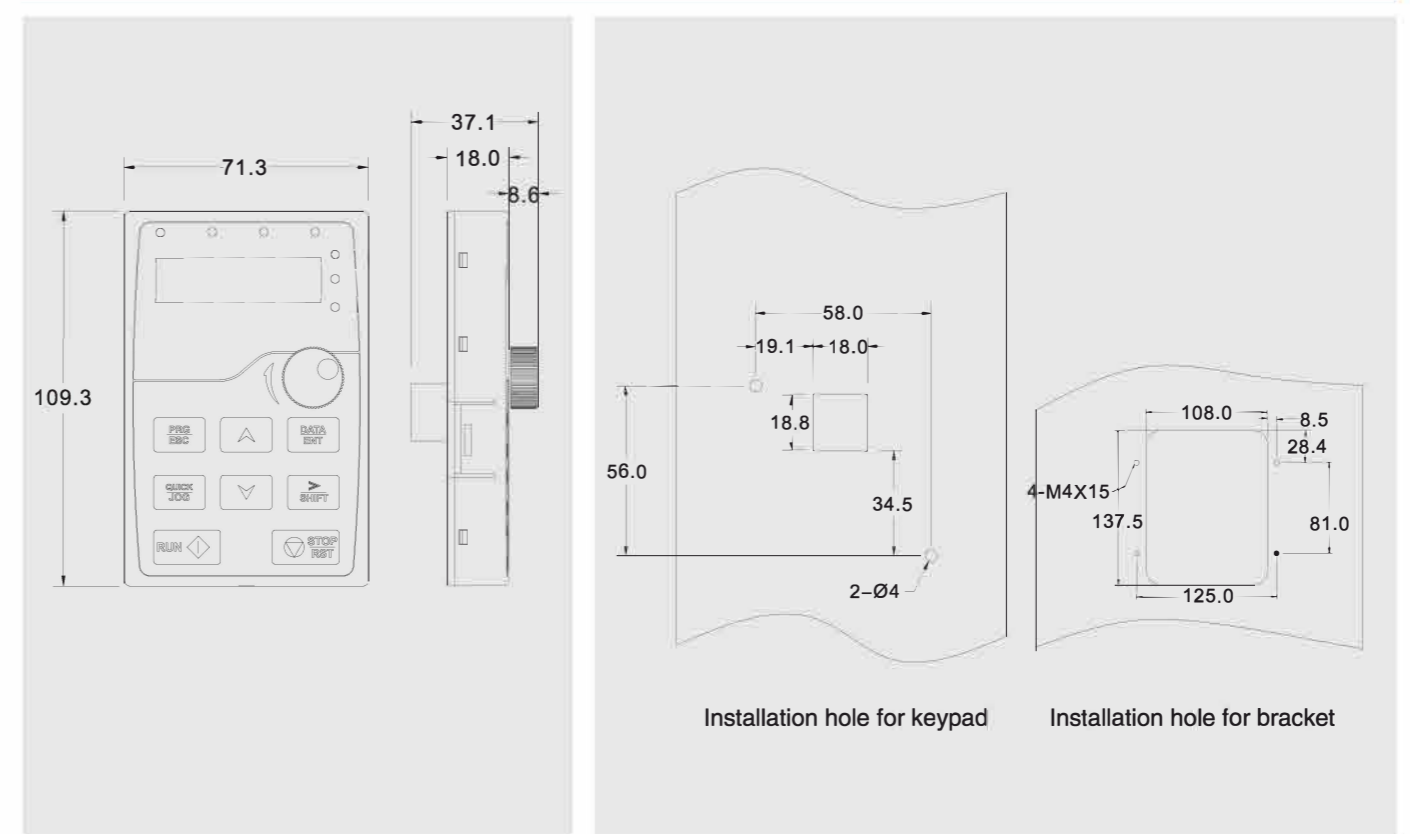

Optional Parts

1.Flange Mounting Panel

Needed for the flange installation of 1.5G-30G/37P inverters.
Not needed for the flange installation of 37G/40P-200G/220P inverters.



2.Installation Base

Only optional in 220G/250P-315G/350P inverters .Its bases can be built in an input AC (or DC) reactor or an output AC reactor



3.Installation bracket for the keypad

Installation bracket or M3 screw can be used in the installation of external keypad.
The bracket of 1.5G-30G//37P inverters is optional .
The bracket of 37G/40P-500G inverters is standard.



4.Heat-releasing Hole

Inverter needs to derate when selecting a cover Consult with the INVT technicians for the detailed information.



5.LCD keypad

10 rows of DH displaying
Compatible with the LED keypad.
Support Chinese/English languages and copy function.



6.AC single-phase 220V input auxiliary power supply

For more convenient debugging

7.Reactor

The inverters of 37G/45P and above can be connected with external DC reactor. The reactor can improve the power factor and avoid damage to the recitifier bridge caused by overcurrent and damage to the rectifier circuit by harmonic

Inverter Model	Input Reactor	DC Reactor	Output Reactor
GD200-1R5G-4	ACL2-1R5-4	—	OCL2-1R5-4
GD200-2R2G-4	ACL2-2R2-4	—	OCL2-2R2-4
GD200-004G/5R5P-4	ACL2-004-4	—	OCL2-004-4
GD200-5R5G/7R5P-4	ACL2-5R5-4	—	OCL2-5R5-4
GD200-7R5G/011P-4	ACL2-7R5-4	—	OCL2-7R5-4
GD200-011G/015P-4	ACL2-011-4	—	OCL2-011-4

Inverter Model	Input Reactor	DC Reactor	Output Reactor
GD200-015G/018P-4	ACL2-015-4	—	OCL2-015-4
GD200-018G/022P-4	ACL2-018-4	—	OCL2-018-4
GD200-022G/030P-4	ACL2-022-4	—	OCL2-022-4
GD200-030G/037P-4	ACL2-030-4	—	OCL2-030-4
GD200-037G/045P-4	ACL2-037-4	DCL2-037-4	OCL2-037-4
GD200-045G/055P-4	ACL2-045-4	DCL2-045-4	OCL2-045-4
GD200-055G/075P-4	ACL2-055-4	DCL2-055-4	OCL2-055-4
GD200-075G/090P-4	ACL2-075-4	DCL2-075-4	OCL2-075-4
GD200-090G/110P-4	ACL2-090-4	DCL2-090-4	OCL2-090-4
GD200-110G/132P-4	ACL2-110-4	DCL2-110-4	OCL2-110-4
GD200-132G/160P-4	ACL2-132-4	DCL2-132-4	OCL2-132-4
GD200-160G/200P-4	ACL2-160-4	DCL2-160-4	OCL2-160-4
GD200-200G/220P-4	ACL2-200-4	DCL2-200-4	OCL2-200-4
GD200-220G/250P-4	ACL2-250-4	DCL2-250-4	OCL2-250-4
GD200-250G/280P-4	ACL2-250-4	DCL2-250-4	OCL2-250-4
GD200-280G/315P-4	ACL2-280-4	DCL2-280-4	OCL2-280-4
GD200-315G/350P-4	ACL2-315-4	DCL2-315-4	OCL2-315-4
GD200-350G/400P-4	Standard	DCL2-350-4	OCL2-350-4
GD200-400G-4	Standard	DCL2-400-4	OCL2-400-4
GD200-500G-4	Standard	DCL2-500-4	OCL2-500-4

8.Filters

Power degree	Input filter	Output filter
1.5G/1.5P	FLT-P04006L-B	FLT-L04006L-B
2.2G/2.2P		
4G/4P	FLT-P04016L-B	FLT-L04016L-B
5.5G/5.5P		
7.5G/7.5P	FLT-P04032L-B	FLT-L04032L-B
11G/11P		
15G/15P	FLT-P04045L-B	FLT-L04045L-B
18.5G/18.5P		
22G/22P	FLT-P04065L-B	FLT-L04065L-B
30G/30P		
37G/37P	FLT-P04100L-B	FLT-L04100L-B
45G/45P		
55G/55P	FLT-P04150L-B	FLT-L04150L-B
75G/75P		
90G/90P	FLT-P04240L-B	FLT-L04240L-B
110G/110P		
132G/132P	FLT-P04400L-B	FLT-L04400L-B
160G/160P		
200G/200P	FLT-P04600L-B	FLT-L04600L-B
220G/220P		
250G/250P	FLT-P04800L-B	FLT-L04800L-B
280G/280P		
315G/315P	FLT-P041000L-B	FLT-L041000L-B
350G/350P		
400G/400P		
500G/500P		

Remark: C2 standard is available if select above external filters .

9.Braking System

The inverters of 30G/37P and below are embedded internal braking units and the inverters of 37G/45P and above need external braking units, please select the braking units according to actual use (the requirement of braking torque and braking usage ratio)The braking resistor will increase the braking torque, the following table is the resistor power designed to different situations and user needs to select according to actual situation.

Model NO.	DBU Model	DBR Value 100% Braking (Ω)	DBR Power 10% Braking(kW)	DBR Power 50% Braking(kW)	DBR Power 80% Braking(kW)	Minimum DBR Value (Ω)
GD200-1R5G-4	Internal Braking Unit	326	0.23	1.1	1.8	170
GD200-2R2G-4		222	0.33	1.7	2.6	130
GD200-004G/5R5P-4		122	0.6	3.0	4.8	80
GD200-5R5G/7R5P-4		89	0.75	4.1	6.6	60
GD200-7R5G/011P-4	Internal Braking Unit	65	1.1	5.6	9.0	47
GD200-011G/015P-4		44	1.7	8.3	13.2	31
GD200-015G/018P-4		32	2	11	18	23
GD200-018G/022P-4		27	3	14	22	19
GD200-022G/030P-4		22	3	17	26	16
GD200-030G/037P-4		16	5	23	36	9
GD200-037G/045P-4	DBU100H-060-4	13	6	28	44	11.7
GD200-045G/055P-4	DBU100H-110-4	10	7	34	54	6.4
GD200-055G/075P-4		8	8	41	66	
GD200-075G/090P-4		6.5	11	56	90	
GD200-090G/110P-4	DBU100H-160-4	5.4	14	68	108	4.4
GD200-110G/132P-4		4.5	17	83	132	
GD200-132G/160P-4	DBU100H-220-4	3.7	20	99	158	3.2
GD200-160G/200P-4	DBU100H-320-4	3.1	24	120	192	2.2
GD200-200G/220P-4		2.5	30	150	240	

Sales Network

Model NO.	DBU Model	DBR Value 100% Braking (Ω)	DBR Power 10% Braking(kW)	DBR Power 50% Braking(kW)	DBR Power 80% Braking(kW)	Minimum DBR Value (Ω)
GD200-220G/250P-4	DBU100H-400-4	2.2	33	165	264	1.8
GD200-250G/280P-4		2.0	38	188	300	
GD200-280G/315P-4	Two DBU100H-320-4	3.6 × 2	21 × 2	105 × 2	168 × 2	2.2 × 2
GD200-315G/350P-4		3.2 × 2	24 × 2	118 × 2	189 × 2	
GD200-350G/400P-4		2.8 × 2	27 × 2	132 × 2	210 × 2	
GD200-400G-4		2.4 × 2	30 × 2	150 × 2	240 × 2	
GD200-500G-4	Two DBU100H-400-4	2 × 2	38 × 2	186 × 2	300 × 2	1.8 × 2



- India subsidiary company in Mumbai
- Russia representative offices in Moscow and St.Peterburg
- Brazil representative office in Sao Paulo
- Australia representative office in Sydney
- Mexico representative office in Mexico City
- Exported to more than 60 countries and regions